

Save This Manual For
Future Reference

SEARS

*owners
manual*

**MODEL NO.
113.236150**

Serial
Number _____

Model and serial number may be
found attached to the right side of
arm housing.

You should record both model
and serial number in a safe place
for future use.

**FOR YOUR
SAFETY:
Read ALL
INSTRUCTIONS
carefully**

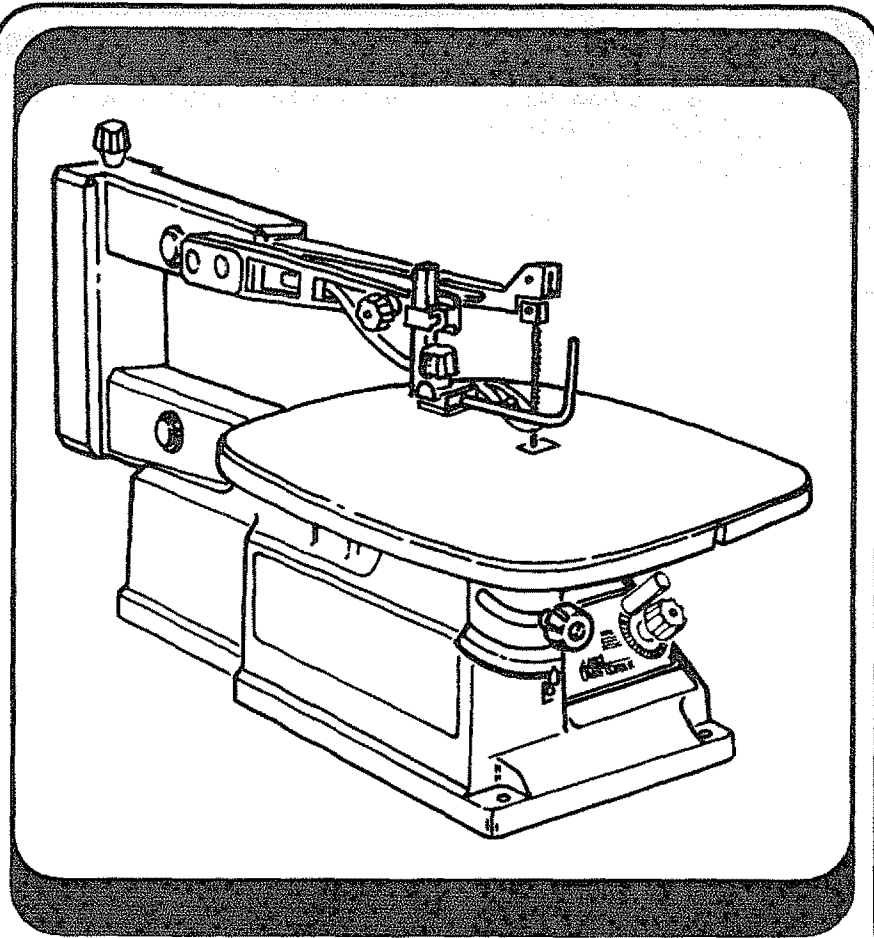

SEARS / CRAFTSMAN®

**16 INCH VARIABLE
SPEED SCROLL SAW**

- *assembly*
- *operating*
- *repair parts*

Sold by SEARS, ROEBUCK AND CO., Chicago, IL. 60684 U.S.A.

FULL ONE YEAR WARRANTY ON CRAFTSMAN SCROLL SAW

If within one year from the date of purchase this Craftsman Scroll Saw fails due to a defect in material or workmanship, Sears will repair it free of charge.

WARRANTY SERVICE IS AVAILABLE BY SIMPLY RETURNING THE CRAFTSMAN SCROLL SAW TO THE NEAREST SEARS RETAIL/CATALOG STORE OR SERVICE CENTER/DEPARTMENT IN THE UNITED STATES.

THIS WARRANTY APPLIES ONLY WHILE THIS PRODUCT IS USED IN THE UNITED STATES.

This warranty gives you specific legal rights and you may also have other rights which vary from state to state.

Sears, Roebuck and Co., D817 WA Hoffman Estates, IL. 60195

Safety Instructions for Scroll Saw

Safety is a combination of common sense, staying alert and knowing how your scroll saw works. Read this manual to understand this saw.

Safety Signal Words

DANGER: means if the safety information is not followed someone **will** be seriously injured or killed.

WARNING: means if the safety information is not followed someone **could** be seriously injured or killed.

CAUTION: means if the safety information is not followed someone **might** be injured.

Before Using The Saw

WARNING: To avoid mistakes that could cause serious permanent injury, do not plug the saw in until the following steps are completed.

- Assembly and alignment (See pages 7-12)
- Learn the use and function of the speed control ON-OFF knob, bevel lock knob, blade holders, blade support, hold down, tension knob, and blade guard. (See pages 14-16)
- Review and understand all safety instructions and operating procedures in this manual.
- Review of the maintenance methods for this saw. (See page 20)
- Read the WARNING label below, found on the base of the saw.

WARNING

1. Read manual before using saw
2. Wear safety goggles that meet ANSI Z37.1 Standards
3. Be sure blade is installed with teeth pointing down
4. Properly adjust holddown
5. Keep fingers away from the moving blade
6. Do not remove jammed cutoff pieces until blade has stopped
7. Maintain proper adjustment of blade tension
8. Hold workpiece firmly against the table
9. Turn power off and wait for blade to stop before adjusting or servicing

When Installing or Moving The Saw

AVOID DANGEROUS ENVIRONMENT. Use the saw in a dry indoor place, protected from rain. Keep work area well lighted.

To Avoid Injury from Unexpected Saw Movement:

- Turn saw off and unplug cord before moving the saw.
- Put the saw on a firm level surface where there is plenty of room for handling and properly supporting the workpiece.
- Support the saw so the table is level and the saw does not rock.
- Bolt the saw to the work surface if it tends to slip, walk, or slide during operations like cutting long heavy boards, or when using an auxiliary table.
- NEVER STAND ON TOOL. Serious injury could occur if the tool tips or you accidentally hit the cutting tool. Do not store anything above or near the tool where anyone might stand on the tool to reach them.

To Avoid Injury or Death from Electrical Shock:

- GROUND THE SAW. This saw has an approved 3 conductor cord and a 3-prong grounding type plug. Use only 3-wire, grounded outlets rated 120 volts, 15 amperes (amps). The green conductor in the cord is the grounding wire. To avoid electrocution, NEVER connect the green wire to a live terminal.
- Make sure your fingers do not touch the plug's metal prongs when plugging or unplugging the saw.

Before Each Use:

Inspect your saw.

DISCONNECT THE SAW. To avoid injury from accidental starting, unplug the saw, turn the switch off and lock out the switch before changing the setup, removing covers, guards or blade.

CHECK DAMAGED PARTS. Check for:

- Alignment of moving parts.
- Binding of moving parts.
- Broken parts.
- Stable mounting.
- Any other conditions that may affect the way the saw works.

If any part is missing, bent or broken in any way, or any electrical parts don't work properly, turn the saw off and unplug the saw. REPLACE damaged, missing or failed parts before using the saw again.

Maintain Tools with Care. Keep the saw clean for best and safest performance. Follow instructions for lubricating.

Remove adjusting keys and wrenches from tool before turning it on.

To avoid injury from jams, slips or thrown pieces:

- Choose the right size and style blade for the material and the type of cutting you plan to do.
- **Use Only Recommended Accessories.**
(See page 21). Consult this owners manual for recommended accessories. Follow the instructions that come with the accessories. The use of improper accessories may cause risk of injury to person.
- Make sure the blade teeth point downward, toward the table.
- Make sure the blade tension is properly adjusted.
- Make sure the bevel lock knob is tight and no parts have excessive play.
- To avoid accidental blade contact, minimize blade breakage and provide maximum blade support, always adjust the work and blade guard to just clear the workpiece.
- **Keep Work Area Clean.** Cluttered areas and benches invite accidents. Floor must not be slippery.

To avoid burns or other fire damage, never use the saw near flammable liquids, vapors or gases.

Plan Ahead to Protect Your Eyes, Hands, Face and Ears

- **Know Your Saw.** Read and understand the owners manual and labels affixed to the tool. Learn it's application and limitations as well as the specific potential hazards peculiar to this tool.
- To avoid injury from accidental contact with moving parts, don't do layout, assembly, or setup work on the saw while any parts are moving.
- **Avoid Accidental Starting.** Make sure switch is "OFF" before plugging saw into a power outlet.

Plan Your Work.

- **Use The Right Tool.** Don't force tool or attachment to do a job it was not designed to do.
- Use this scroll saw to cut only wood, wood-like products, plastics and non-ferrous metals.

CAUTION: This saw is NOT designed for cutting ferrous metals like iron or steel. When cutting non-ferrous metals (brass, copper and aluminum, etc.), metal shavings can react with wood dust and start a fire. To avoid this:

• Remove all traces of wood dust from on and around the saw.

• Remove all metal shavings from on or around the saw before sawing wood again.

Dress for safety.



Any power saw can throw foreign objects into the eyes. This can cause permanent eye damage. Wear safety goggles (not glasses) that comply with ANSI Z87.1 (shown on package). Everyday eyeglasses have only impact resistant lenses. They are not safety glasses. Safety goggles are available at Sears Retail Stores. Glasses or goggles not in compliance with ANSI Z87.1 could seriously hurt you when they break.

- Do not wear loose clothing, gloves, neckties or jewelry (rings, wristwatches). They can get caught and draw you into moving parts.
- Wear nonslip footwear.
- Tie back long hair.
- Roll long sleeves above the elbow.
- Noise levels vary widely. To avoid possible hearing damage, wear ear plugs or muffs when using saw for hours at a time.
- For dusty operations, wear a dust mask along with the safety goggles.

Inspect Your Workpiece.

Make sure there are no nails or foreign objects in the part of the workpiece to be cut.

Use Extra Caution with Large, Very Small or Awkward Workpieces:

- Never use this tool to finish pieces too small to hold by hand.
- Use extra supports (tables, saw horses, blocks, etc.) for any workpieces large enough to tip when not held down to the table top.
- **Never** use another person as a substitute for a table extension, or as additional support for a workpiece or to help feed, support or pull the workpiece.
- When cutting irregularly shaped workpieces, plan your work so it will not pinch the blade. A piece of molding, for example, must lay flat or be held by a fixture or jig that will not let it twist, rock or slip while being cut.
- Properly support round material such as dowel rods or tubing. They have a tendency to roll during a cut, causing the blade to "bite". To avoid this, always use "V" block.
- Cut only one workpiece at a time.
- Clear everything except the workpiece and related support devices off the table before turning the saw on.

Safety Instructions for Scroll Saw

Plan the Way You Will Hold the Workpiece from Start to Finish.

- Do not hand hold pieces so small that your fingers will go under the blade guard. Use jigs or fixtures to hold the work and keep your hands away from the blade.
- Avoid awkward operations and hand positions where a sudden slip could cause fingers or hand to move into the blade.
- **Don't Overreach.** Keep good footing and balance.
- Keep your face and body to one side of the blade, out of line with a possible thrown piece if the blade should break.

Whenever Saw Is Running:

WARNING: Don't let familiarity (gained from frequent use of your scroll saw) cause a careless mistake. A careless fraction of a second is enough to cause a severe injury.

- Before starting your cut, watch the saw while it runs. If it makes an unfamiliar noise or vibrates excessively, stop immediately. Turn the saw off. Unplug the saw. Do not restart until finding and correcting the problem.
- **Keep Children Away.** Keep all visitors a safe distance from the saw. Make sure bystanders are clear of the saw and workpiece.
- **Don't Force Tool.** It will do the job better and safer at its designed rate. Feed the workpiece into the saw blade only fast enough to let it cut without bogging down or binding.

Before Freeing Any Jammed Material.

- Turn switch "OFF"
- Unplug the saw.
- Wait for all moving parts to stop.

When backing up the workpiece, the blade may bind in the kerf (cut). This is usually caused by sawdust clogging up the kerf. If this happens:

- Turn switch "OFF".
- Unplug the saw.
- Wait for all moving parts to stop.
- With a flat blade screwdriver, turn motor shaft by hand, by inserting into the slotted end of motor shaft located at the center of the motor housing. Do this while backing up the workpiece.

Before removing loose pieces from the table, turn saw off and wait for all moving parts to stop.

Before Leaving the Saw:

- Wait for all moving parts to stop.
- **Make Workshop Child-proof.** Unplug the saw. Lock the shop or ON/OFF knob. Store the key away from children and others not qualified to use the tool.

Motors Specifications and Electrical Requirements

This machine is equipped with a variable speed motor. It is wired for operation on 120V, 60Hz, alternating current.

CAUTION: A direct current motor is used in this saw. Changes to the internal wiring will create a fire hazard and may also create a shock hazard.

For replacement motor and control board, refer to parts list in this manual.

Connecting To Power Supply Outlet

If power cord is worn or cut, or damaged in any way, have it replaced immediately.

WARNING: If not properly grounded, this power tool can cause an electrical shock, particularly when used in damp locations close to plumbing. If an electrical shock occurs there is potential of a secondary hazard, such as your hands contacting the saw blade.

If you are not sure that your outlet, as pictured below, is properly grounded, have it checked by a qualified electrician.

Your unit is for use on 120 volts and has a plug that looks like the illustration below.

This power tool is equipped with a 3-conductor cord and grounding type plug which has a grounding prong approved by Underwriters' Laboratories. The ground conductor has a green jacket and is attached to the tool housing at one end and to the ground prong in the attachment plug at the other end.

This plug requires a mating 3-conductor grounded type outlet as shown.

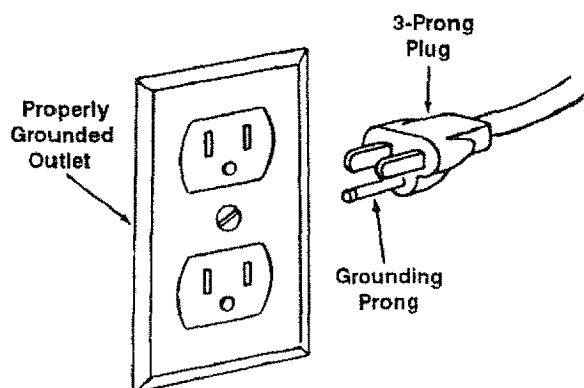

WARNING: Do not permit fingers to touch the terminals of plug when installing or removing the plug to or from the outlet.

Plug power cord into a 120V properly grounded type outlet.

If the outlet you are planning to use for the power tool is of the 2-prong type, **Do Not Remove Or Alter The Grounding Prong In Any Manner.** Use an adapter as shown below and always connect the grounding lug to known ground.

It is recommended that you have a qualified electrician replace the TWO prong outlet with a properly grounded THREE prong outlet.

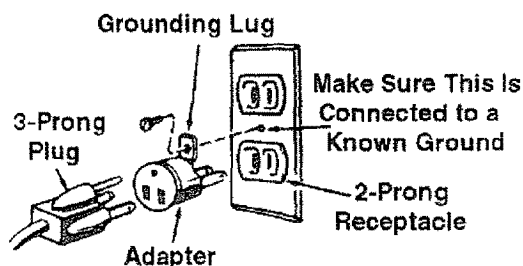

An adapter, as illustrated, is available for connecting plugs to 2-prong receptacles.

WARNING: The green grounding lug extending from the adapter must be connected to a permanent ground such as to a properly grounded outlet box. Not all outlet boxes are properly grounded.

If you are not sure that your outlet box is properly grounded, have it checked by a qualified electrician.

NOTE: The adapter illustrated is for use only if you already have a properly grounded 2-prong receptacle.

The use of any extension cord will cause some loss of power.

Use only 3-wire extension cords which have 3-prong grounding type plugs and 3-prong receptacles which accept the tools plug.

Length of the Conductor	Wire Sizes Required (American Wire Gauge Number) 120V Lines
Up to 100 feet	No. 16

Glossary of Terms for Woodworking

1. **Kerf** - the slot cut by the blade.
2. **Leading Edge** - the edge of the workpiece which is pushed into the blade first.
3. **Sawblade Path** - the area of the workpiece directly in line with and moving toward the sawblade edge.
4. **Bevel** - the ability to slant the table to make angle cuts. An angle cutting operation through the face of the board.
5. **Blade Tooth Set** - the distance that the edge of the sawblade tooth is bent (or set) outward from the side of the blade.
6. **Trailing Edge** - the workpiece edge last cut by the sawblade.
7. **Workpiece** - the item on which the cutting operation is being performed.

Contents

Warranty Information.....	2	Mounting the Scroll Saw	13
Safety Instructions for Scroll Saws.....	2	Getting to Know Your Scroll Saw.....	14
Motor Specs and Electrical Requirements	5	Speed Control/On-OFF Knob	15
Glossary of Terms for Woodworking	6	Choice of Blade and Speed.....	16
Unpacking and Checking Contents.....	6	Operation	17
Assembly and Alignment.....	7	Making Interior Cuts	19
Setting Table for Horizontal or Bevel Cutting	8	Maintenance.....	20
Aligning the Bevel Indicator	8	Wiring Diagram	21
Removing and Installing Blades.....	10	Recommended Accessories	21
Adjusting Work Hold-Down Foot.....	12	Troubleshooting.....	21
Dust Blower.....	12	Repair Parts	22
Blade Guard.....	12	Service Information.....	Back Cover

Unpacking and Checking Contents

Tools Needed



WARNING: For your own safety never connect plug to power source outlet until all assembly steps are complete, and you have read and understand the safety and operating instructions.

IMPORTANT: Never lift this saw by the arm which holds the blade or damage will occur to your saw.

Separate all parts from packaging materials and check each item with illustration and "Table of Loose Parts". Make certain all items are accounted for before discarding any packaging material.

If any parts are missing, do not attempt to assemble the Scroll Saw, plug in the power cord or turn the switch on until the missing parts are obtained and installed correctly.

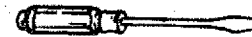

MEDIUM STANDARD SCREWDRIVER



MEDIUM PHILLIPS SCREWDRIVER

Table of Loose Parts	Qty
A 16" Scroll Saw (Completely Assembled).....	1
B Owner's Manual	1
C Loose Parts Bag containing:	
Blade.....	1
Hex "T" Handle Wrench	1
"L" Shaped Blade Change Rod.....	1

NOTE: Hardware to mount this scroll saw to a bench or leg set is NOT supplied. See mounting instructions for recommended hardware size.

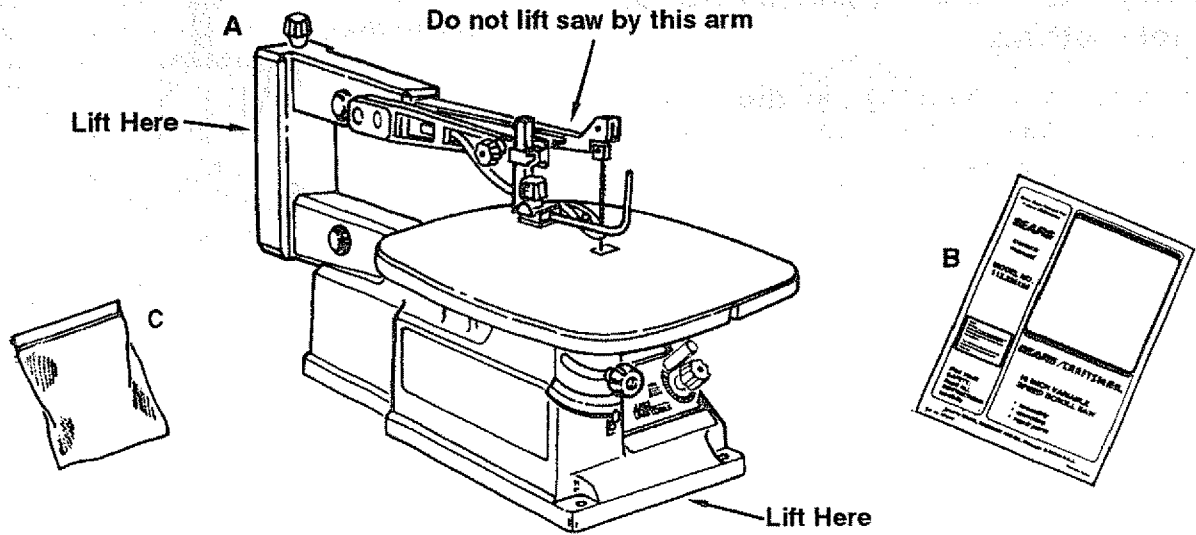

Assembly and alignment

WARNING: For your own safety, never connect plug to power source outlet until all assembly steps are complete, and you have read and understood the safety and operating instructions.

1. Lift the saw by the frame and base and place scroll saw on work bench.
2. Familiarize yourself with the controls and features of this scroll saw indicated in the illustration.

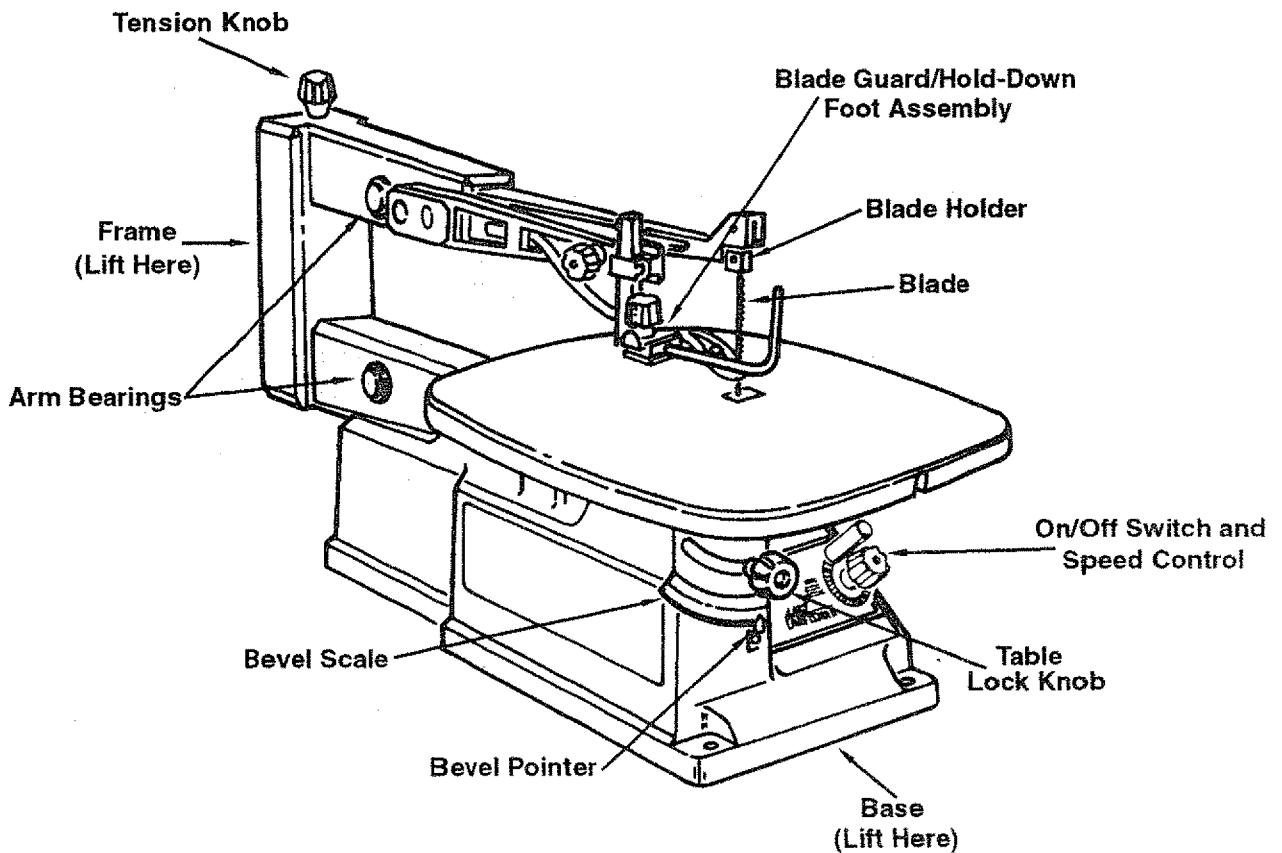

Setting the Table for Horizontal or Bevel Cutting

1. The scroll saw work table can be tilted to the left for bevel cutting up to 45° from the 0° or horizontal cutting position.

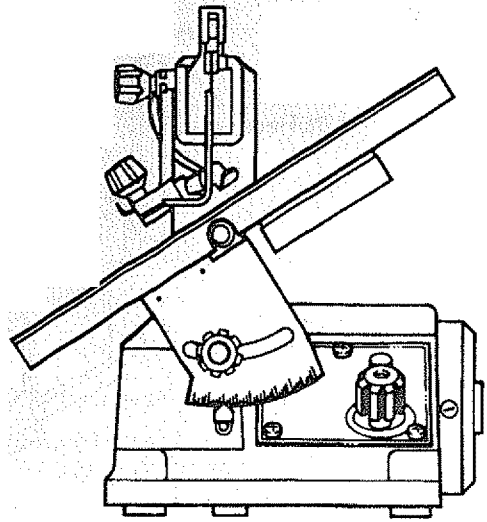

2. A bevel scale is provided under the work table as a convenient reference for setting the approximate table angle for bevel cutting.

When greater precision is required, make practice cuts and adjust the table as necessary for your requirements.

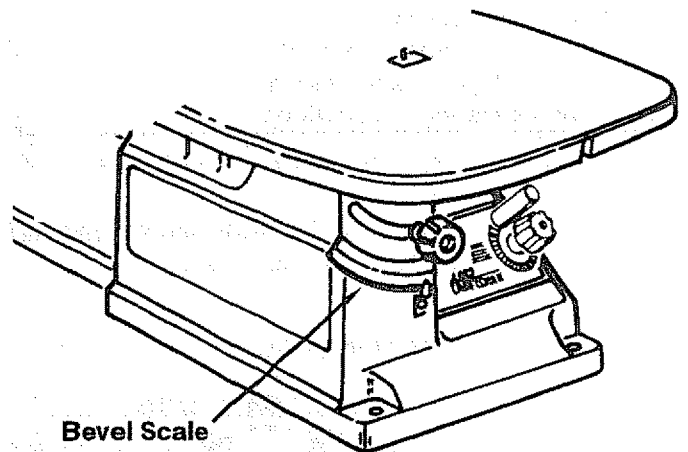

To Align the Bevel Indicator

1. Loosen the table bevel lock knob and move the table until it is approximately perpendicular, or at a right angle, to the blade.

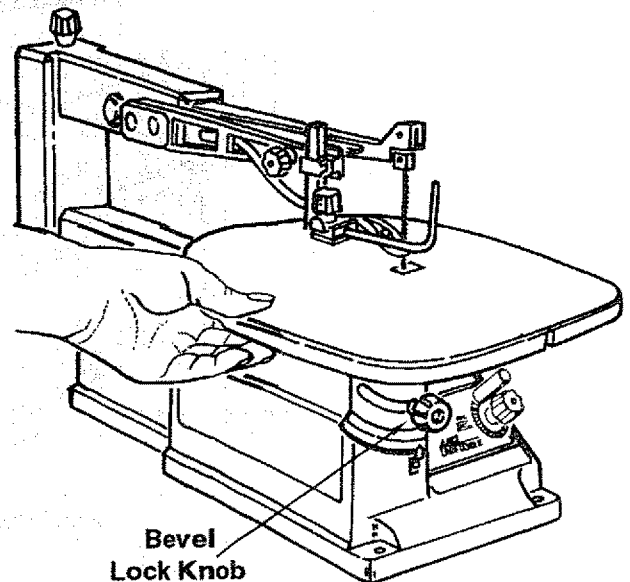

2. Use a small square to set the table at 90° to the blade. If there is too much space between the square and the blade, the table must be adjusted.

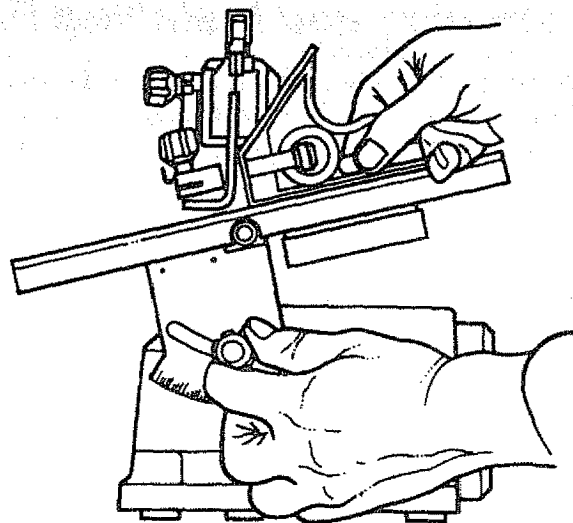

3. When the space between the square and the blade is minimal, tighten the bevel lock knob. The table should now be approximately 90° to the blade.

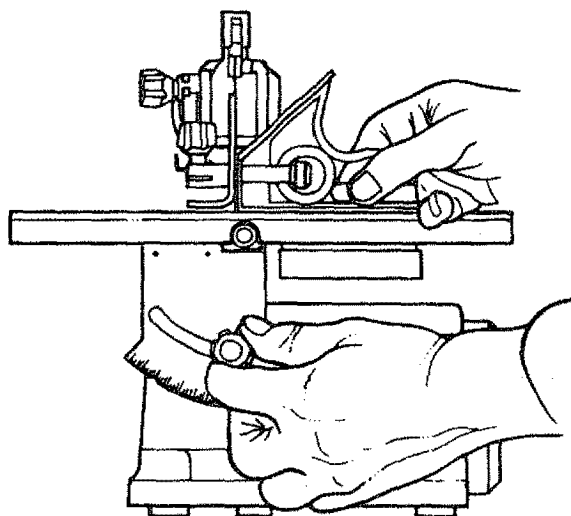

4. Loosen the screw holding the bevel scale pointer and adjust to 0°. Tighten screw.

Remember, the bevel scale is a convenient guide but should not be relied upon for precision.

Make practice cuts in scrap wood to determine if your angle settings are correct. Adjust the table as required.

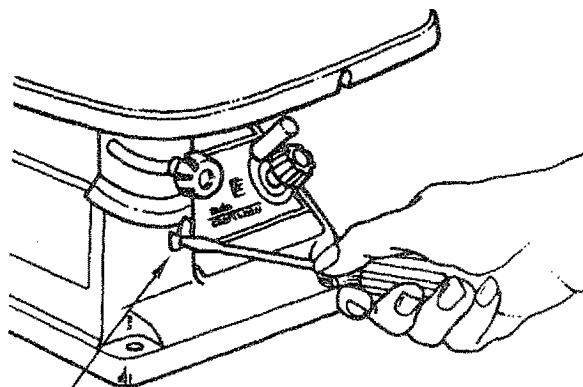

Bevel
Pointer

Removing and Installing Blades

WARNING: To avoid injury from accidental starting, always turn switch "OFF" and unplug power cord from outlet before removing or replacing the blade.

NOTE: Saw comes set up for pin end blades. If you are going to use plain end blades, refer to the instructions under "Installing Plain End Blades" below.

Removing Pin End Blades

1. Unplug power cord from outlet and check that switch is off.
2. Loosen tension on blade by turning tension knob counterclockwise  about three full turns.
3. Remove blade from the lower blade holder by pushing down on the upper arm, releasing the blade/pin from the lower blade holder. Remove blade from the upper blade holder by slightly lifting up on the blade and pulling forward.

Installing Pin End Blades

NOTE: The saw comes from the factory already set up for pin end blades.

1. Pin End Blade Set Up: Insert the blade change rod through the hole above the upper blade holder. Use the "T" handle wrench to loosen the hex socket screw and clamp from the upper blade holder. Install the clamp so that the boss goes into the recess in the blade holder. The "V" notches must line up.
2. Tighten the hex socket screw.
3. Repeat this procedure on the lower blade holder.
4. Check that the tension knob is loose.
5. Install the blade through the insert opening with the teeth pointing down. Engage the pin into the "V" notch of the lower blade holder.
6. Pull up on the blade and engage the upper pin in the notch of the upper blade holder.
7. Carefully tighten the blade tension by turning the tension knob clockwise  until you feel the slack in the blade is removed.
8. Check to see that the pins are properly located in the slots. Turn the tension knob an additional two full turns clockwise. This amount of blade tension should do well for most cutting operations and blades. The number of turns will be approximately two full turns. This will vary depending on blade thickness and blade type.
9. Make sure the blade is properly installed. Before applying power, rotate the motor shaft by hand using a screwdriver in the motor shaft slot as shown.

WARNING: To avoid injury from thrown objects, remove the blade change rod and all tools from the saw.

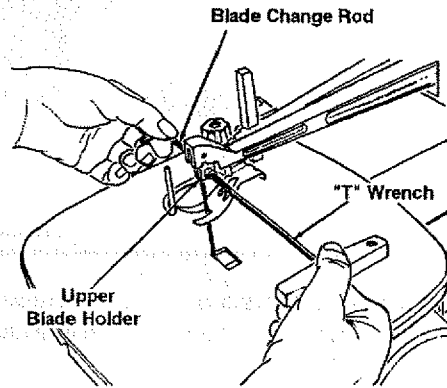
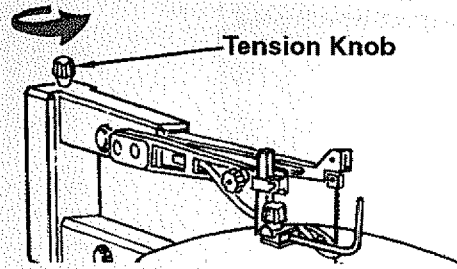

NOTE: Teeth pointing downward.

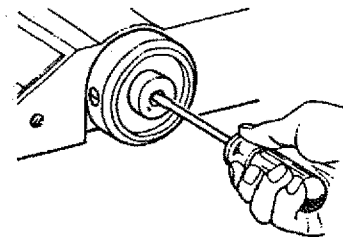
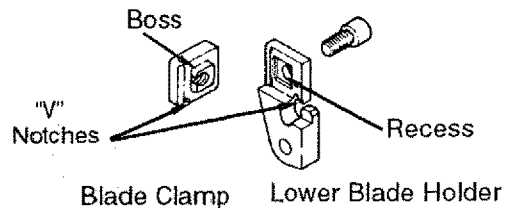
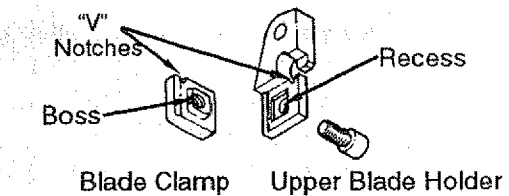
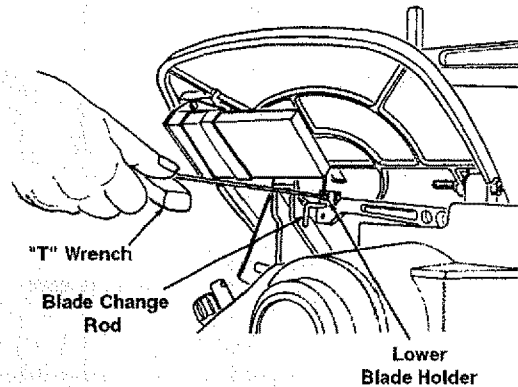

WARNING: To avoid injury from accidental starting, always turn switch "OFF" and unplug power cord from outlet before removing or replacing the blade.

NOTE: Saw comes set up for pin end blades. For plain end blades, the blade clamp needs to be reinstated with the flat surface placed against the blade holder.

Removing Plain End Blades

1. Unplug power cord from outlet and check that switch is off.
2. Loosen tension on blade by turning tension knob counterclockwise  about three full turns.
3. Insert the blade change rod through the hole above the blade holder and loosen the hex socket screw of the blade holder with the "T" wrench.
4. Remove blade from upper blade holder.
5. Loosen the lower blade holder hex socket screw in the same way as the upper blade holder in step 3.
6. Remove blade from lower blade holder.

Installing Plain End Blades

NOTE: For plain end blades, the flat surface of the blade clamp needs to be positioned against the blade holder.

1. Plain End Blade Set Up: Insert the blade change rod through the hole above the upper blade holder. Use the "T" handle wrench to loosen the hex socket screw and clamp from the upper blade holder. Install the clamp so that the flat surface is against the blade holder.
2. Replace the hex socket screw.
3. Repeat this procedure on the lower blade holder.
4. Install the blade through the hole in the table and into the lower blade holder. The blade teeth should point down. Position the blade end at the bottom of the blade clamp and against the hex socket screw.
5. Tighten the hex socket screw, using the "T" wrench, while holding the blade change rod in position.
6. Use the same procedure to install the blade into the upper blade holder. Before tightening the socket hex screw, adjust the position of the upper blade holder by turning the blade tension knob until the end of the blade is near the top of the blade holder.
7. Remove the "T" wrench and the blade change rod from the blade holder.
8. Tighten the blade tension knob clockwise  until the blade is tensioned. The number of turns will be approximately two full turns. This will vary depending on blade thickness and blade type.
9. Make sure the blade is properly installed. Before applying power, rotate the motor shaft by hand using a screwdriver in the motor shaft as shown on page 10.

WARNING: To avoid injury from thrown objects, remove the blade change rod and all tools from the saw.

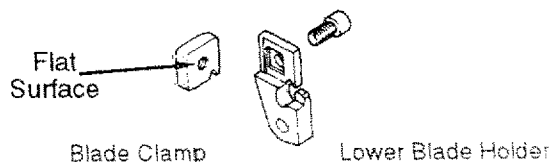
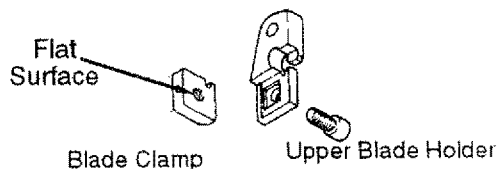
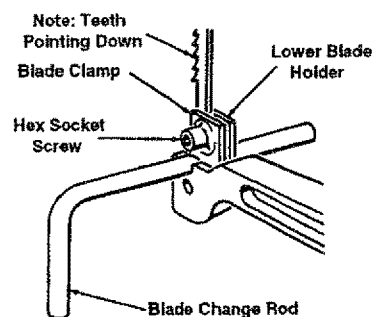
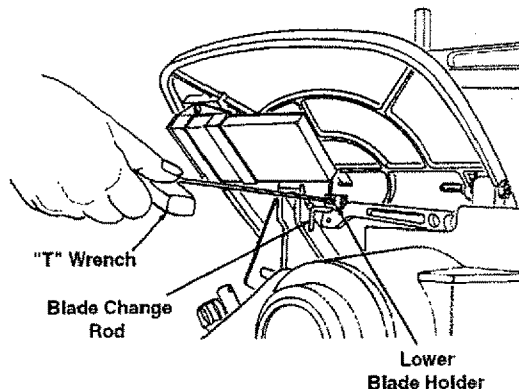
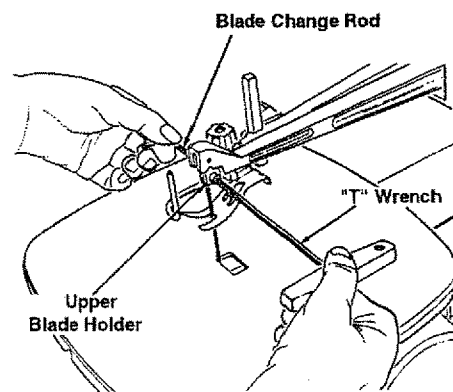
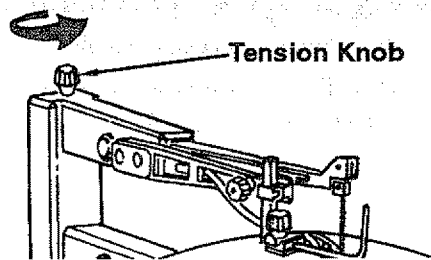

Over Tensioning Or Under Tensioning

of the blade will cause blades to break rapidly.

The thicker, harder and more abrasive the wood you are cutting, the more blades you will have to use.

Blade breakage is caused by the following:

- Over tension or under tension.
- Twisting or bending the blade.
- Over use - blade life exhausted.
- **Over Aggressive Feeding** of the workpiece into the blade by going too fast.

ADJUSTING WORK HOLD-DOWN FOOT

WARNING: To avoid injury from accidental starting, always turn switch "OFF" and unplug power cord from outlet before removing or replacing the blade.

The purpose of the work hold-down foot is to hold the work against the table so that it is less likely to lift with the up stroke of the blade. It should lie flat on the work with the front prongs straddling the blade.

1. The work hold-down foot is attached to the blade guard wire. The height of the work hold-down foot is adjusted by loosening the height adjustment knob and moving the guide post up or down. The work hold-down foot is adjusted front to back and left-to-right by loosening the hold-down knob located on the bracket, as illustrated.
2. When the table is tilted, the work hold-down foot can be adjusted by loosening the height adjustment knob and adjusting the foot to the same angle as the table. The work hold-down foot should always be adjusted as close to the blade as possible without touching and positioned directly on the surface of the workpiece.

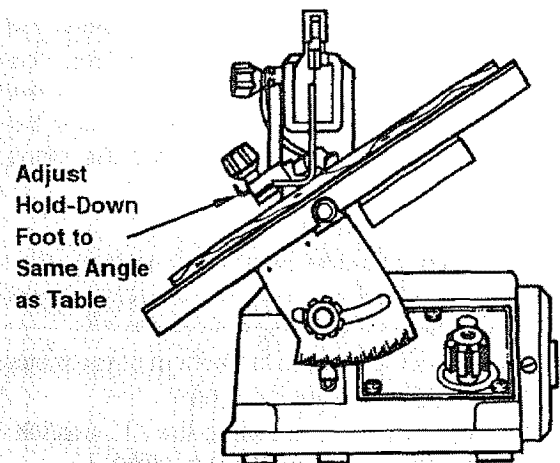
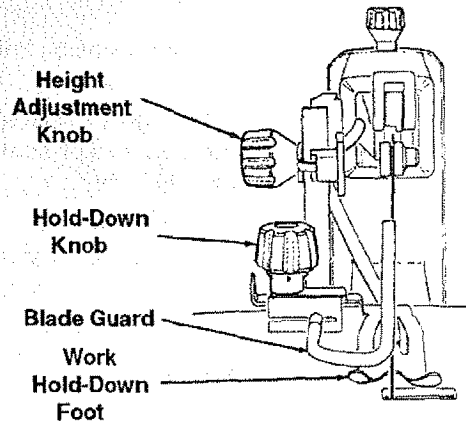

Dust Blower

The dust blower will direct air to the most effective point on the cutting line when the hold down is adjusted. No adjustment is necessary to the blower.

Blade Guard

The blade guard will always be positioned parallel to the blade. No adjustment is necessary.

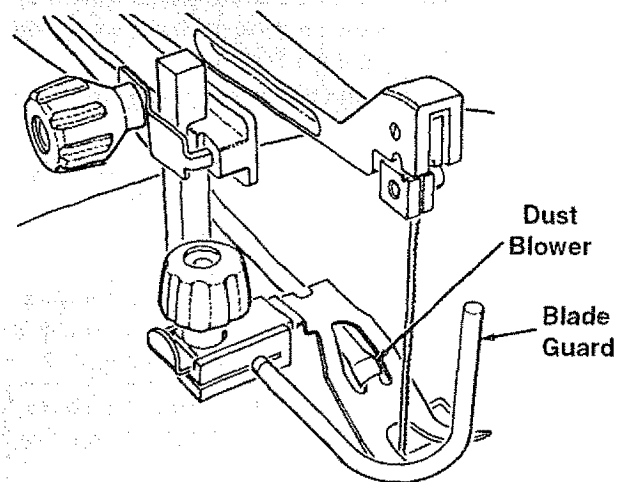

Mounting the Scroll Saw to a Bench

1. When mounting this saw to a workbench a solid wood bench is preferred over a plywood bench where noise and vibration will be more noticeable.
2. Hardware to mount this saw to a workbench is **Not** supplied with the saw. However, we recommend the hardware used be not smaller than the following.

Description	Qty.
Hex Head Screw, 1/4-20 x length required.....	3
Flat Washers, 1/4 I.D.	6
Lock Washers, 1/4 I.D.	3
Hex Nuts, 1/4-20	6

3. A soft foam pad to place between your scroll saw and workbench is **NOT** supplied with the saw. However, we highly recommend the use of such a pad to reduce noise and vibration.

Description	Qty.
Soft foam pad such as carpet padding, 24" x 12" x 1/2"	1

Do NOT over tighten mounting bolts - leave some cushion in the foam pad for absorbing noise and vibration.

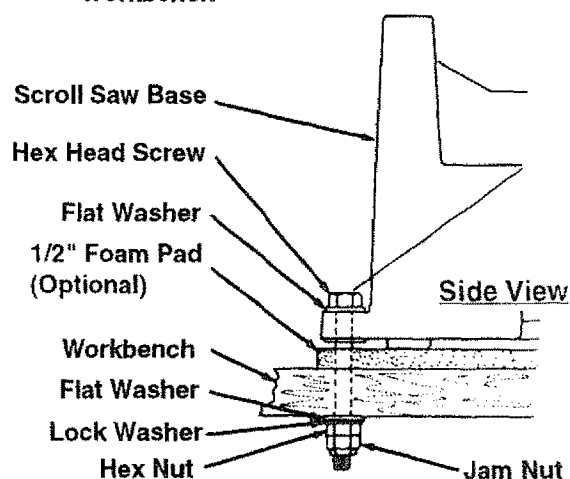
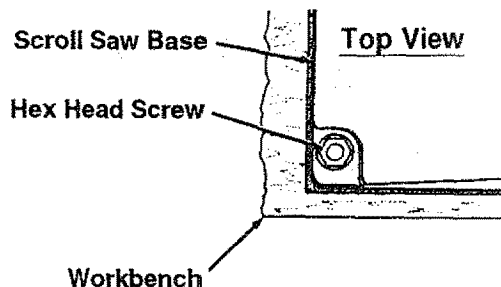

4. If you prefer to mount your saw to a leg set, we recommend the leg set for bench top tools which is available through Sears Retail Stores. The number of this leg set is 9-22244. This leg set is an optional accessory and instructions to mount the scroll saw to this leg set are included in the leg set package.

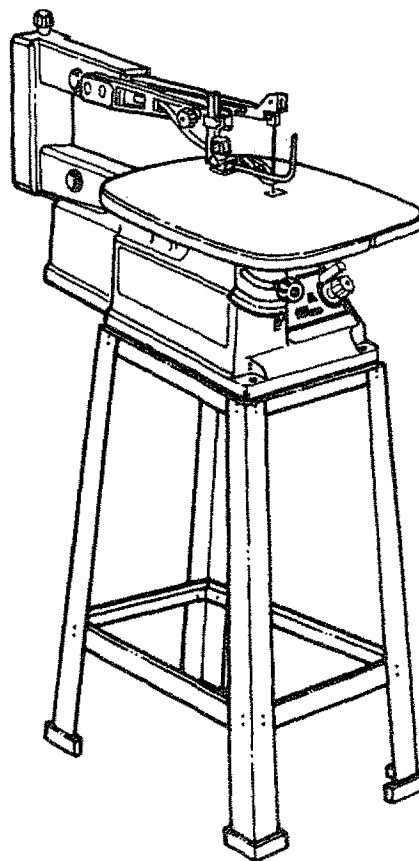

Getting to Know Your Scroll Saw

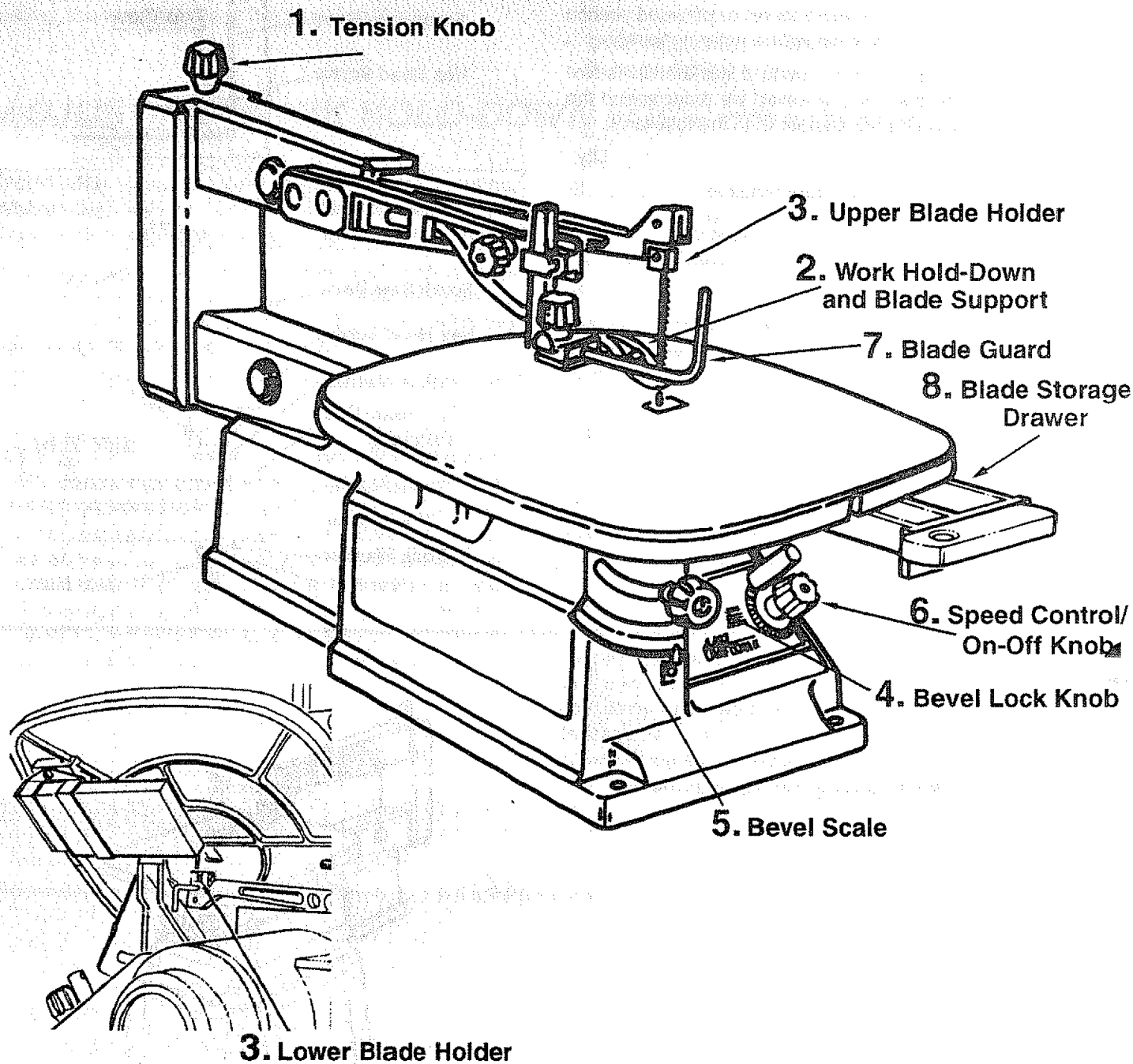

- 1. Tension Knob** ... Tightening the knob (clockwise) will increase the tension on the blade. Loosening it (counterclockwise) will decrease the tension.
- 2. Work Hold-Down and Blade Support** ... Provides added control of work-piece, protection for operator and support for the blade.
- 3. Blade Holders** ... Retain and position the blade.
- 4. Bevel Lock Knob** ... Loosening knob allows the table to tilt up to 45° for bevel cuts.

- 5. Bevel Scale** ... Shows angle table is tilted for bevel cutting.
- 6. Speed Control/On-Off Knob** ... For speed control setting, refer to the "Choice of Blade and Speed" table. The On-Off knob has a locking feature, **This Feature Is Intended To Help Prevent Unauthorized Use By Children And Others.**
- 7. Blade Guard** ... Defines area of moving blade.
- 8. Blade Storage Drawer** ... Used to store blades, "T" handle wrench, and "L" shaped rod.

Speed Control/On-Off Knob

1. To turn machine 'On', place fingers on Speed Control/On-Off Knob and pull out.

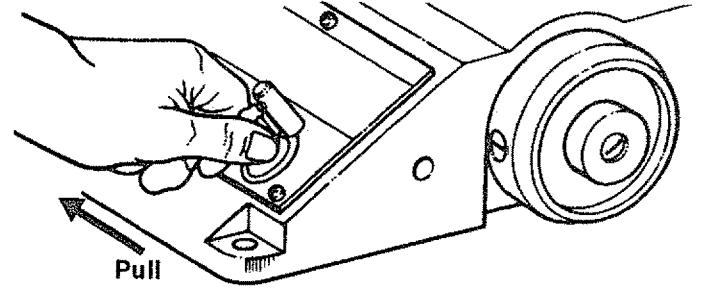

2. To turn machine 'OFF', push in Speed Control/On-Off Knob. **Never Leave The Machine Unattended Until It Has Come To A Complete Stop.**

The variable speed control may be adjusted to the approximate speeds identified on the control panel. Suggested speeds are identified under "Choice of Blade and Speed". Turn the control knob clockwise (↻) strokes per minute and counterclockwise (↺) to reduce the strokes per minute.

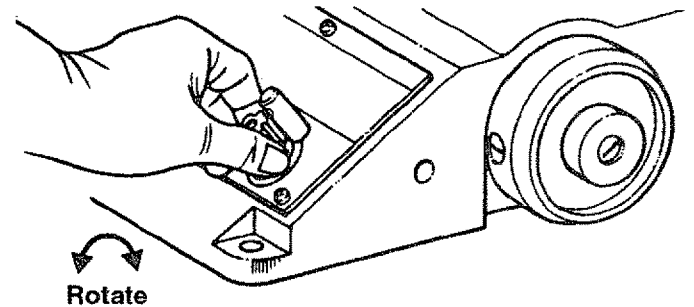
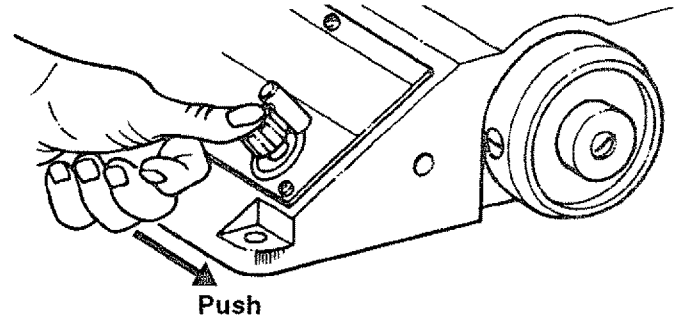

3. To lock knob in 'Off' position, install a padlock through the post above the knob as illustrated, and lock the padlock. (Padlock is not supplied with the saw.)

WARNING: For your own safety, always push the knob 'Off' when machine is not in use. Also, in the event of a power failure (all of your lights go out), push knob 'Off'. 'Lockout' your knob with a padlock as shown. This will prevent the machine from starting up again when the power comes back on.

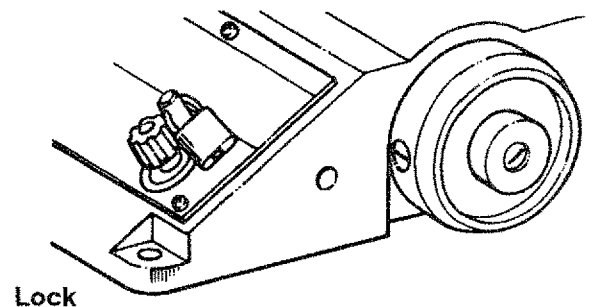

Choice of Blade and Speed

Your scroll saw accepts a wide variety of 5" plain end and pin end blades. As a general guide:

1. Use a finer tooth blade for cutting thin workpiece, when a smoother cut is required for hard materials or when using slower saw speeds.
2. Use a coarser tooth blade for cutting thicker workpieces, when making straight cuts, for medium to soft materials or when using faster saw speeds.
3. Use a blade that will have at least 2 teeth in the material at all times.
4. Use thin, narrow blades for tight radius work, and thick wide blades for large curves and straight cuts.

Listed below are examples of some blades and their intended uses:

Pin and Plain end Blades

Teeth/Inch	Width	Thickness	Speed	Application
20 15	.029" .110"	.012" .018"	500-600	Tight radius work; 3/32" to 1/8" wood veneer, wood, bone, fiber, plastics, non-ferrous metals, etc.
12.5	.038"	.016"	600-1200	Close radius cutting in materials 3/32" to 1/2" thick. Good for hard and soft wood, bone, horn, plastics, etc.
11.5 10	.053" .110"	.018" .018"	1200-1700	For hard and soft woods and woodlike products 3/16" to 2".

Basic Saw Operations

Please, read and understand the following items about your scroll saw before attempting to use the saw.

1. The saw does not cut wood by itself. You allow the saw to cut wood by guiding the wood into the blade as it moves.
2. The blade teeth cut wood **Only** on the down stroke.
3. You must guide the wood into the blade slowly because the teeth of the blade are very small and they can only remove wood when they are on the down stroke.
4. There is a learning curve for each person who wants to use this saw. During that period of time it is expected that some blades will break until you learn how to use the saw and receive the greatest benefit from the blades.
5. Best results are achieved when cutting wood less than one inch thick.
6. When cutting wood thicker than one inch the user must guide the wood very, very slowly into the blade and take extra care not to bend or twist the blade while cutting in order to maximize blade life.
7. Teeth on scroll saw blades wear out and as such must be replaced frequently for best cutting results. Scroll saw blades generally stay sharp for 1/2 hour to 2 hours of cutting.
8. To get accurate cuts, be prepared to compensate for blade's tendency to follow the wood grain as you are cutting.
9. This scroll saw is intended to cut wood, wood like products, plastics and non-ferrous metals.
10. When choosing a blade to use with your scroll saw, consider the following carefully.
 - Very fine, narrow blades should be used to scroll cut in thin wood 1/4 inch thick or less.
 - To cut wood over 1/4 inch thick, use wider blades.
 - Most blade packages state the size or thickness of wood which that blade is intended to cut, and the radius, size of curve, which can be cut with that blade.
 - Wider blades can't cut curves as tight or small as thinner blades.
 - Narrower blades work well only on thinner wood material.
11. This saw uses 5 inch long, pin end type, blades only. See your Sears Retail Store for accessory blades.
12. Blades wear faster when cutting plywood, which is very abrasive; when sawing wood which is thicker than the 7/8 inch blade stroke; and when sawing hardwood, or when side pressure is placed on the blade.

Before Each Use:

Inspect your saw.

Disconnect The Saw. To avoid injury from accidental starting, turn the switch "OFF", unplug the saw before changing the setup, removing covers, guards or blade.

CHECK DAMAGED PARTS. Check for:

- Alignment of moving parts.
- Binding of moving parts.
- Broken parts.
- Stable mounting.
- Any other conditions that may affect the way the saw works.

If any part is missing, bent or broken in any way, or any electrical parts don't work properly, turn the saw off and unplug the saw. **Replace** damaged, missing or failed parts before using the saw again. **Keep Guard In Place** and in working order

Maintain Tools With Care

Keep the saw clean for best and safest performance. Follow instructions for lubricating.

Remove Adjusting Keys And Wrenches from tool before turning it on.

To avoid injury from jams, slips or thrown pieces:

- Choose the right size and style blade for the material and the type of cutting you plan to do.
- **Use Only Recommended Accessories.** (See page 21). Consult this Owner's manual for recommended accessories. Follow the instructions that come with the accessories. The use of improper accessories may cause risk of injury to persons.
- Make sure the blade teeth point downward, toward the table.
- Make sure the blade tension is properly adjusted.
- **Keep Work Area Clean.** Cluttered areas and benches invite accidents. Floor must not be slippery.

To avoid burns or other fire damage, never use the saw near flammable liquids, vapors or gases.

Plan Ahead To Protect Your Eyes, Hands, Face And Ears

Know Your Saw. Read and understand the owners manual and labels affixed to the tool. Learn it's applications and limitations as well as the specific potential hazards peculiar to this tool.

To avoid injury from accidental contact with moving parts, don't do layout, assembly or setup work on the saw while any parts are moving.

Avoid Accidental Starting. Make sure switch is "OFF" before plugging saw into a power outlet.

Plan your work.

- **Use The Right Tool.** Don't force tool or attachment to do a job it was not designed to do.
- Use this scroll saw to cut only wood, wood-like products, plastics and non-ferrous metals.

CAUTION: This saw is **NOT** designed for cutting ferrous metals like iron or steel. When cutting non-ferrous metals (brass, copper and aluminum, etc.), metal shavings can react with wood dust and start a fire. To avoid this:

- Remove all traces of wood dust from inside the saw.
- Remove all traces of metal dust from on or around the saw before sawing wood again.

Dress for safety.

Any power saw can throw foreign objects into the eyes. This can cause permanent eye damage. Wear safety goggles (not glasses) that comply with ANSI Z87.1 (shown on package). Everyday eyeglasses have only impact resistant lenses. They are not safety glasses. Safety goggles are available at Sears Retail Stores. Glasses or goggles not in compliance with ANSI Z87.1 could seriously hurt you when they break.

- Do not wear loose clothing, gloves, neckties or jewelry (rings, wristwatches). They can get caught and draw you into moving parts.
- Wear non-slip footwear.
- Tie back long hair.
- Roll long sleeves above the elbow.
- Noise levels vary widely. To avoid possible hearing damage, wear ear plugs or muffs when using saw for hours at a time.
- For dusty operations, wear a dust mask along with the safety goggles.

Inspect your workpiece.

Make sure there are no nails or foreign objects in the part of the workpiece to be cut.

Use extra caution with large, very small or awkward workpieces:

- Never use this tool to finish pieces too small to hold by hand.
- Use extra supports (tables, saw horses, blocks, etc.) for any workpiece large enough to tip when not held down to the table top.
- **Never** use another person as a substitute for a table extension, or as additional support for a workpiece or to help feed, support or pull the workpiece.
- When cutting irregularly shaped workpieces, plan your work so it will not pinch the blade. A piece of molding, for example, must lay flat or be held by a fixture or jig that will not let it twist, rock or slip while being cut.
- Properly support round material such as dowel rods or tubing. They have a tendency to roll during a cut, causing the blade to "bite". To avoid this, always use a "V" block.
- Cut only one workpiece at a time.
- Clear everything except the workpiece and related support devices off the table before turning the saw on.

Plan the way you will hold the workpiece from start to finish.

Do not hand hold pieces so small that your fingers will go under the blade guard. Use jigs or fixtures to hold the work and keep your hands away from the blade.

Avoid awkward operations and hand positions where a sudden slip could cause fingers or hand to move into the blade.

Don't Overreach. Keep good footing and balance.

Keep your face and body to one side of blade, out of line with a possible thrown piece if the blade should break.

Whenever Saw Is Running

WARNING: Don't let familiarity (gained from frequent use of your saw) cause a careless mistake. A careless fraction of a second is enough to cause a severe injury.

Before starting your cut, watch the saw while it runs. If it makes an unfamiliar noise or vibrates a lot, stop immediately. Turn the saw off. Unplug the saw. Do not restart until finding and correcting the problem.

Keep Children Away. Keep all visitors a safe distance from the saw. Make sure bystanders are clear of the saw and workpiece.

Don't Force Tool. It will do the job better and safer at its designed rate. Feed the workpiece into the saw blade only fast enough to let it cut without bogging down or binding.

Before freeing any jammed material:

- Turn switch "OFF".
- Unplug saw.
- Wait for all moving parts to stop.

When backing up the workpiece, the blade may bind in the kerf (cut). This is usually caused by sawdust clogging up the kerf. If this happens:

- Turn switch "OFF".
- Unplug saw.
- Wait for all moving parts to stop.
- With a flat blade screwdriver, turn the motor by hand while backing up the workpiece.

Before removing loose pieces from the table, turn saw off and wait for all moving parts to stop.

Before Leaving The Saw:

- Wait for all moving parts to stop.

Make Workshop Child-proof. Unplug the saw. Lock the shop or ON/OFF knob. Store the key away from children and others not qualified to use the tool.

Making Interior Scroll Cuts

1. One of the features of this saw is that it can be used to make scroll cuts on the interior of a board without breaking or cutting into the outline or perimeter of the board.

WARNING: To avoid injury from accidental starting, always turn switch "OFF" and remove plug from power source outlet before removing or replacing the blade.

2. To make interior cuts in a board, remove the scroll saw blade as explained in the Assembly section.
3. Drill a 1/4" or larger hole in the board you will use to make interior cuts.
4. Place the board on the saw table with the hole in the board over the access hole in the table.
5. Install the blade through the hole in the board and adjust blade tension.
6. When finished making the interior scroll cuts, simply remove the blade from the blade holders, as described in the Assembly section, and remove the board from the table.

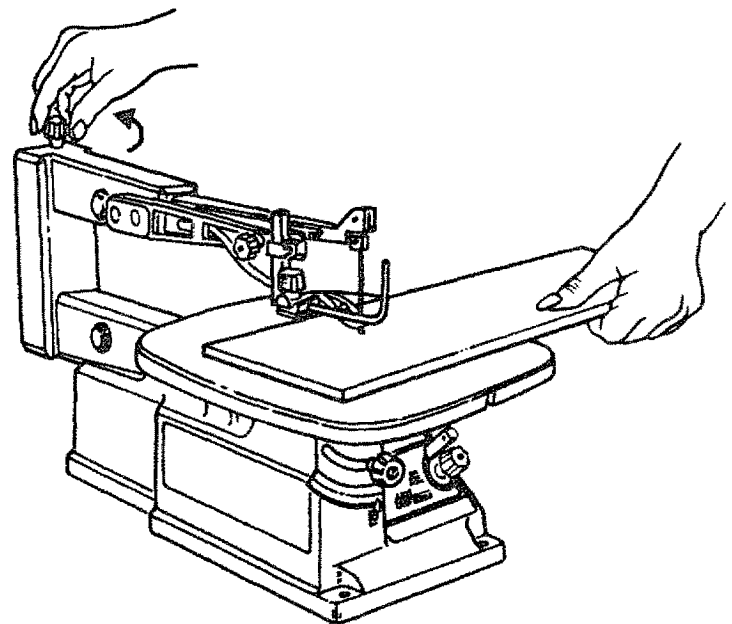

Maintenance

WARNING: For your own safety, push control knob "OFF" and remove plug from power source outlet before maintaining or lubricating your saw.

General

An occasional coat of paste wax on the work table will allow the wood being cut to glide smoothly across the work surface.

Motor/electrical

The motor bearings are permanently lubricated and require no further lubrication.

Do not attempt to oil the motor bearings or service the motor internal parts.

WARNING: If the power cord is worn, cut or damaged in any way, have it replaced immediately.

WARNING: To avoid fire or electrocution, reassemble electric parts with only approved service parts. Reassemble exactly as originally assembled.

Arm Bearings

Lubricate the arm bearings after 10 hours of use. Re-oil after every 50 hours of use or whenever there is a squeak coming from the bearings.

1. Turn saw on its side.
2. Squirt a generous amount of SAE 30 oil around the shaft end and bronze bearing.
3. Let the oil soak in overnight in this condition.
4. Next day repeat the above procedure for the opposite side of the saw.

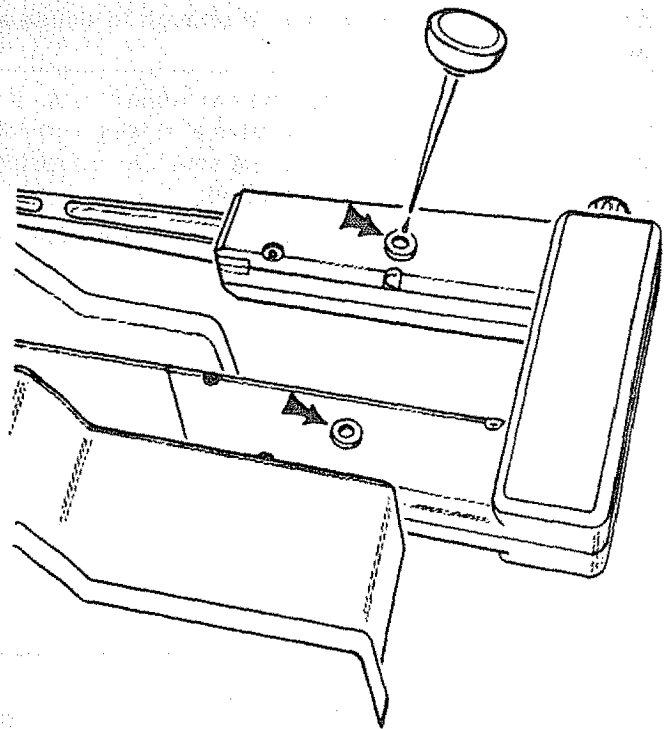

Replacing Motor Brushes

The carbon brushes that come with this saw are designed to give long service life. When one or both brushes become shorter than 1/4", replace both brushes.

1. Remove the brush cap using a 1/4" flat blade screwdriver.

NOTE: The brushes are spring loaded and may push against the brush cap as it releases.

2. Install the new brush assembly and reinstall the brush cap.
3. Use the cap to push the spring and brass end of the assembly into the rectangular hole as the cap is tightened. Be sure that the brush cap is fully seated in the brush holder.
4. Repeat the procedure for the other brush.

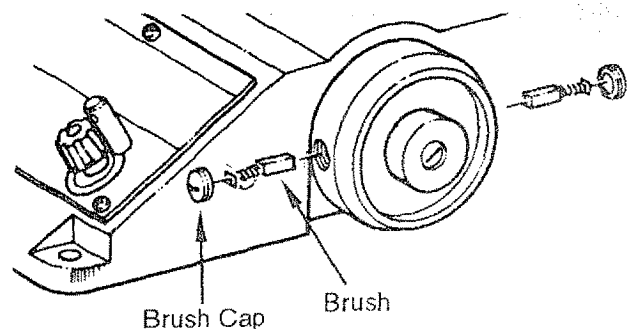

Wiring Diagram

WARNING: To avoid fire or shock, use only recommended service parts and reassemble exactly as originally assembled.

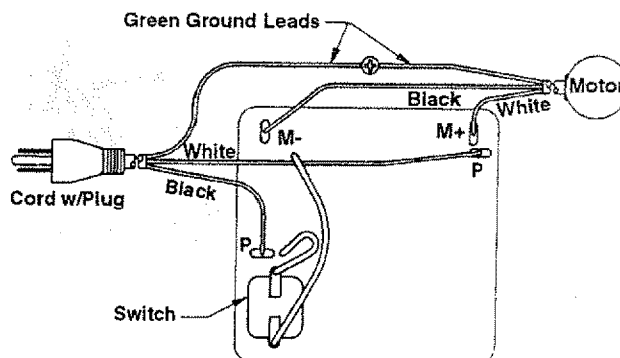

Sears recommends the following accessories

Item	Sears Number
Leg Set	9-22244
Blades	See Sears Retail Store for 5" long Plain End/Pin End blades

Sears may recommend other accessories not listed in manual. See your nearest Sears Store for other accessories.

Troubleshooting

WARNING: For your own safety, turn switch "OFF", and remove plug from power source outlet before troubleshooting your scroll saw.

PROBLEM	PROBABLE CAUSE	REMEDY SCHEDULED
Breaking Blades.	<ol style="list-style-type: none"> 1. Wrong tension 2. Over working blade. 3. Wrong blade application. 4. Twisting blade in wood. 	<ol style="list-style-type: none"> 1. Adjust blade tension. 2. Reduce feed rate. 3. Use narrow blades for cutting thin wood, wide blades for thicker wood. 4. Avoid side pressure on blade.
Motor will not run.	<ol style="list-style-type: none"> 1. Damaged cord or plug. 2. Damaged motor or control board. 	<ol style="list-style-type: none"> 1. Replace damaged parts before using saw again. 2. Consult Sears Service. Any attempt to repair this motor or control board may create a HAZARD unless repair is done by a qualified service technician. Repair service is available at your nearest Sears Store.
Vibration NOTE: There will always be some vibration present when the saw is running because of the blade and arm movement.	<ol style="list-style-type: none"> 1. Improper mounting of the saw. 2. Unsuitable mounting surface. 3. Loose table 4. Loose motor mounting. 	<ol style="list-style-type: none"> 1. See mounting instructions in this manual for proper mounting technique. 2. The heavier your workbench is, the less vibration will occur. A plywood workbench will not be as good a work surface as the same size solid lumber. Use common sense in choosing a mounting surface. 3. Tighten table lock knob. 4. Tighten motor mounting screws.
Motor stops during cuts	<ol style="list-style-type: none"> 1. Aggressive feeding causes Current Protector to shut motor off. 	<ol style="list-style-type: none"> 1. Turn machine "OFF" and then back "ON" to continue cutting. 2. Slow down the feed rate of material into blade.

**PARTS LIST FOR CRAFTSMAN 16" VARIABLE SPEED SCROLL SAW
MODEL NO. 113.236150**

Always order by Part Number - Not by Key Number

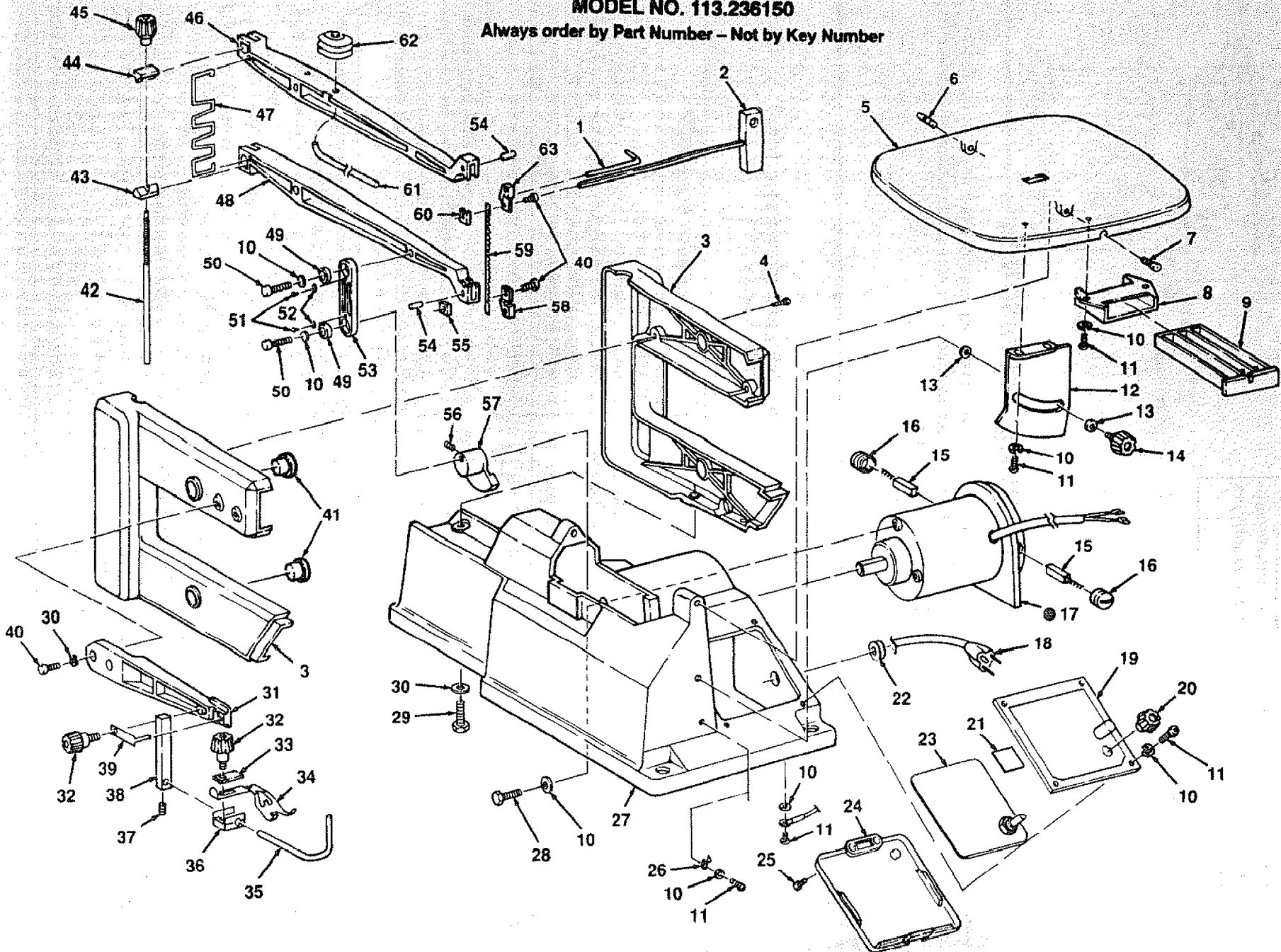

**PARTS LIST FOR CRAFTSMAN 16" VARIABLE SPEED SCROLL SAW
MODEL NO. 113.236150**

Always Order By Part Number-Not By Key Number

Key No.	Part No.	Description
1	820733	Rod, Blade Change
2	820333	Wrench, "T" Handle, 4mm
3	822426-1	Housing (Includes Key #4 & 41)
4	820376-2	Screw Pan Hd Ty "TT" M4 x 0.7-28
5	821673	Table
6	813249-131	Pin, Roll M5 x 25
7	821701	Screw, Support
8	821708	Guide, Drawer
9	821707	Drawer
10	STD852005	* Lockwasher, M5
11	821389	Screw, Pan Hd M5 x 0.8-8
12	821702	Support, Scale
13	STD851006	* Washer, 6mm
14	821697	Knob
15	820322	Brush
16	820324	Cap, Brush
17	822428	* Motor
18	821712	Cord with Plug
19	821985	Housing, Control (includes label)
20	821675	Knob
21	821720	Gasket
22	819293	Grommet
23	821719	Board, Controller
24	821672	Cover, Switch Box
25	817450-5	Screw, Pan Hd Self Tap M4 x 18
26	821722	Indicator, Tilt
27	821677	Base (Includes Labels)
28	821151-1	Screw Hex Hd M5 x 0.8-15
29	820249-1	Screw Hex Hd M6 x 1.0-20
30	STD852006	* Lockwasher, M6
31	821683	Support, Hold Down
32	821697-1	Knob

Key No.	Part No.	Description
33	821690	Support, Plate
34	821692	Spring, Hold Down
35	821693	Guard, Blade
36	821691	Clamp, Hold Down
37	818471-6	Screw, Hex Soc Set, M5 x 0.8-5
38	821689	Support Bar
39	821716	Plate Clip
40	820379-1	Screw, Hex Soc Cap, M5 x 0.8-8
41	821717	Bearing, Flanged
42	821704	Bolt, Tension
43	816018	Wedge, Tension
44	816017	Nut, Tension
45	821675-1	Knob
46	821666	Arm, Upper
47	66061	Spring
48	821668	Arm, Lower
49	818468	Bearing, Ball 625ZZ
50	818469	Screw, Hex Soc Cap, M5 x 0.8-16
51	817450-1	Screw, Pan Hd Self Tap M4 x 16-8
52	46-58600-3	* Washer, 4.2 x 10 x 0.9
53	821706	Link, Arm
54	813249-127	Pin, Roll M5 x 14
55	820317	Clamp, Lower Blade
56	818471	Screw, Hex Soc Set, M6 x 1.0-6
57	821709	Coupling, Eccentric
58	820314	Holder, Lower Blade
59	9-26877	† Blade, Scroll Saw
60	820316	Clamp, Upper Blade
61	819248-1	Hose
62	821703	Bellows
63	820315	Holder, Upper Blade
—	SP5641	Owner's Manual (Not Illustrated)

* Standard hardware item - may be purchased locally.

† Stock item - may be secured through the Hardware department of most Sears Retail Stores

* Any attempt to repair this motor may create a hazard unless repair is done by a qualified service technician. Repair service is available at your nearest Sears store.

Repair Parts

IMPORTANT

Supplement for Model 113.236150

Keep this sheet with your owner's manual for future reference

This sheet supplements the owner's manual packed with your scroll saw. The instructions and illustrations shown on this supplement should be followed whenever changing blades.

Refer to your variable speed 16 in scroll saw owner's manual for safety instructions and proper use of the scroll saw.

Removing and Installing Blades

WARNING: To avoid injury from accidental starting, always turn switch "OFF" and unplug power cord from outlet before removing or replacing the blade.

NOTE: Saw comes set up for pin end blades. If you are going to use plain end blades, refer to the instructions under "Installing Plain End Blades".

Removing Pin End Blades

1. Unplug power cord from outlet and check that switch is off.
2. Loosen tension on blade by turning tension knob counterclockwise  about three full turns.
3. Remove blade from the lower blade holder by pushing down on the upper arm, releasing the blade/pin from the lower blade holder. Remove blade from the upper blade holder by slightly lifting up on the blade and pulling forward.

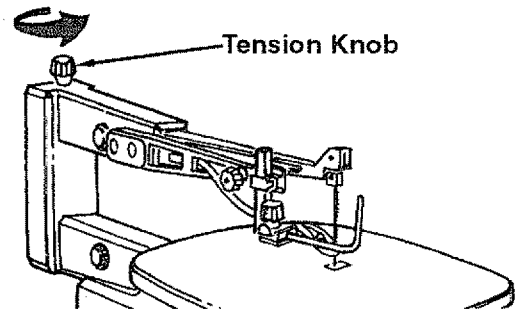

Installing Pin End Blades

NOTE: The saw comes from the factory already set up for pin end blades.

1. Pin End Blade Set Up: Insert the blade change rod through the hole above the upper blade holder. Use the "T" handle wrench to loosen the hex socket screw and clamp from the upper blade holder. Install the clamp so that the thick boss goes into the recess in the blade holder. The "V" notches must line up.
2. Tighten the hex socket screw.
3. Repeat this procedure on the lower blade holder.
4. Check that the tension knob is loose.
5. Install the blade through the insert opening with the teeth pointing down. Engage the pin into the "V" notch of the lower blade holder.
6. Pull up on the blade and engage the upper pin in the "V" notch of the upper blade holder.
7. Carefully tighten the blade tension by turning the tension knob clockwise  until you feel the slack in the blade is removed.
8. Check to see that the pins are properly located in the slots. Turn the tension knob an additional two full turns clockwise. This amount of blade tension should do well for most cutting operations and blades. The number of turns will be approximately two full turns. This will vary depending on blade thickness and blade type.
9. Make sure the blade is properly installed. Before applying power, rotate the motor shaft by hand using a screwdriver in the motor shaft slot as shown.

WARNING: To avoid injury from thrown objects, remove the blade change rod and all tools from the saw.

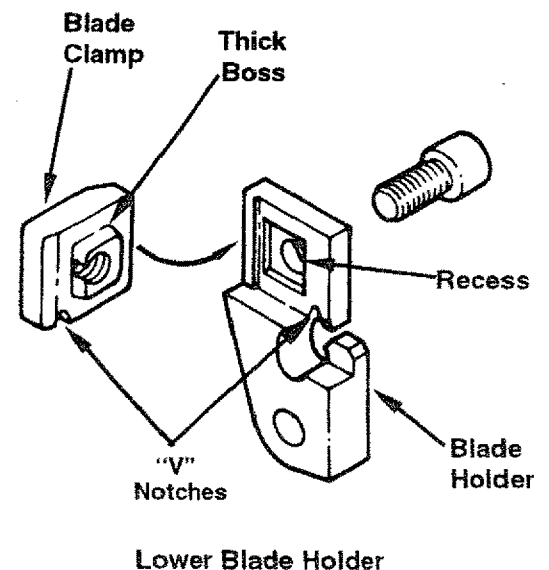
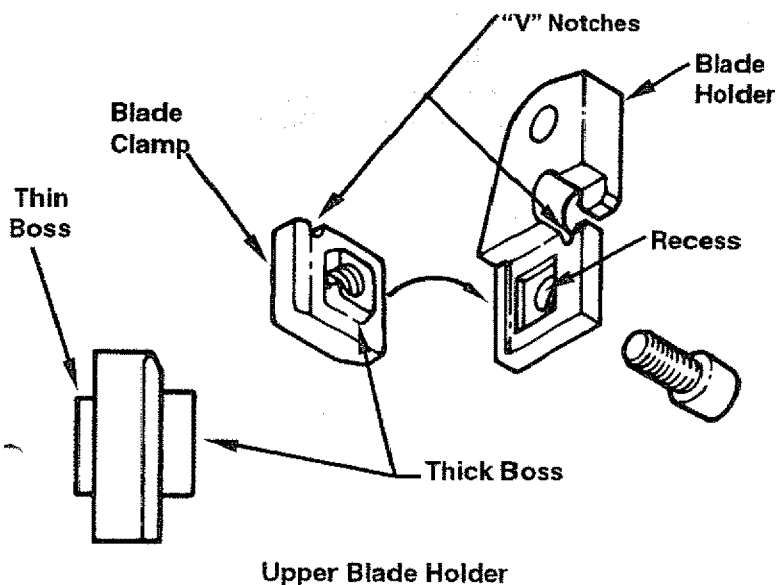
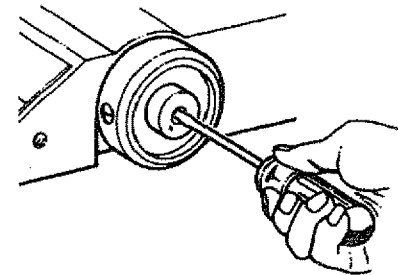
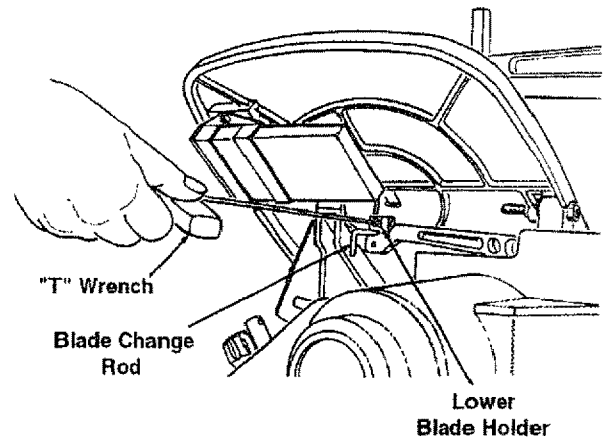
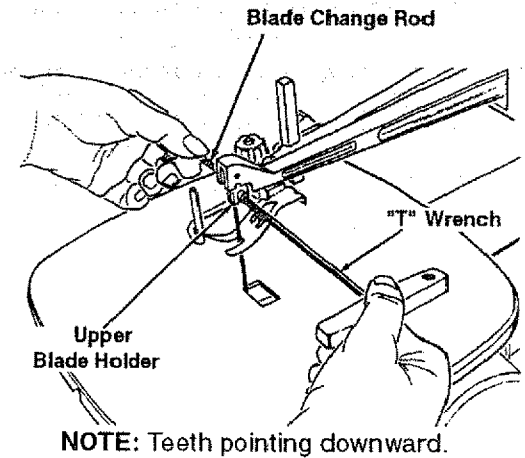

WARNING: To avoid injury from accidental starting, always turn switch "OFF" and unplug power cord from outlet before removing or replacing the blade.

NOTE: Saw comes set up for pin end blades. For plain end blades, the blade clamp needs to be reinstated with the thin boss placed against the blade holder.

Removing Plain End Blades

1. Unplug power cord from outlet and check that switch is off.
2. Loosen tension on blade by turning tension knob counterclockwise  about three full turns.
3. Insert the blade change rod through the hole above the blade holder and loosen the hex socket screw of the blade holder with the "T" wrench.
4. Remove blade from upper blade holder.
5. Loosen the lower blade holder hex socket screw in the same way as the upper blade holder in step 3.
6. Remove blade from lower blade holder.

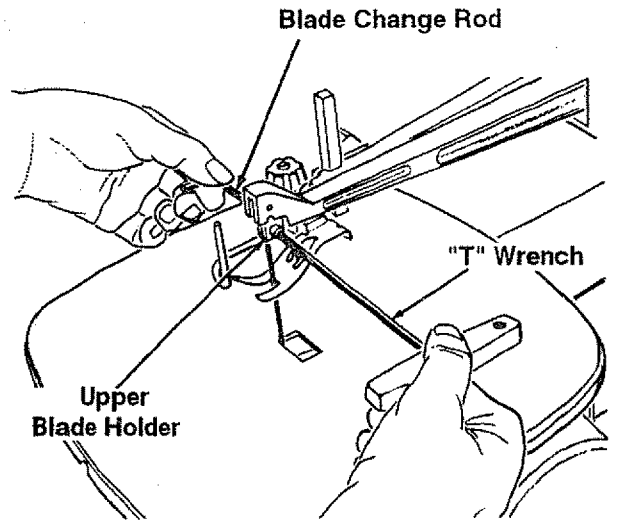
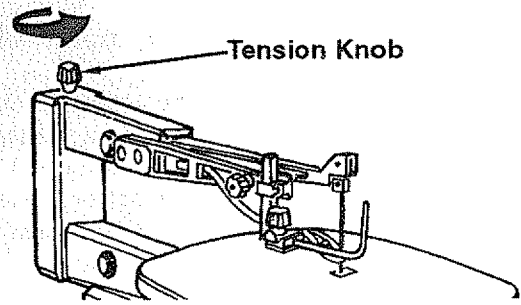

NOTE: Teeth pointing downward.

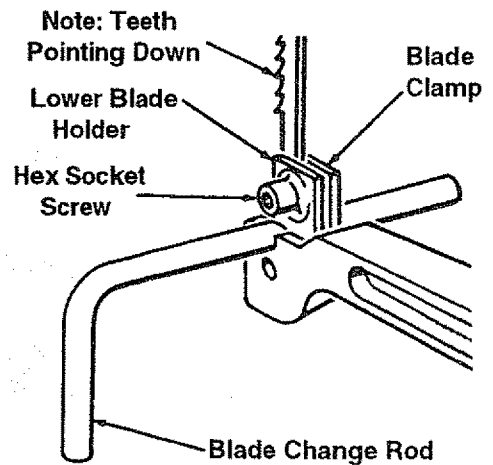
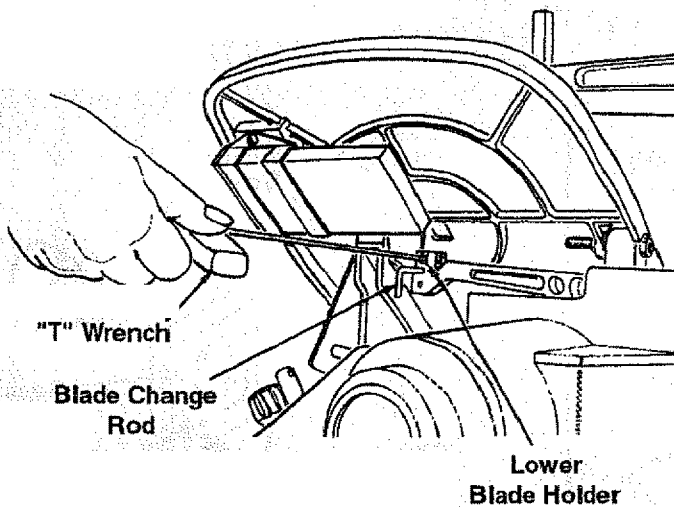

Installing Plain End Blades

NOTE: For plain end blades, the thin boss of the blade clamp needs to be positioned against the blade holder.

Plain End Blade Set Up: Insert the blade change rod through the hole above the upper blade holder. Use the "T" handle wrench to loosen the hex socket screw and clamp from the upper blade holder. Install the clamp so that the thin boss is against the blade holder, and the beveled edge is in the corner of the blade holder. The thin boss side of the blade clamp can be identified by a circular impression placed on the surface.

2. Replace the hex socket screw.
3. Repeat this procedure on the lower blade holder.
4. Install the blade through the hole in the table and into the lower blade holder. The blade teeth should point down. Position the blade end at the bottom of the blade clamp and against the hex socket screw.
5. Tighten the hex socket screw, using the "T" wrench, while holding the blade change rod in position.
6. Use the same procedure to install the blade into the upper blade holder. Before tightening the socket hex screw, adjust the position of the upper blade holder by turning the blade tension knob until the end of the blade is near the top of the blade holder.
7. Remove the "T" wrench and the blade change rod from the blade holder.

Tighten the blade tension knob clockwise  until the blade is tensioned. The number of turns will be approximately two full turns. This will vary depending on blade thickness and blade type.

9. Make sure the blade is properly installed. Before applying power, rotate the motor shaft by hand using a screwdriver in the motor shaft as shown on the previous page.

WARNING: To avoid injury from thrown objects, remove the blade change rod and all tools from the saw.

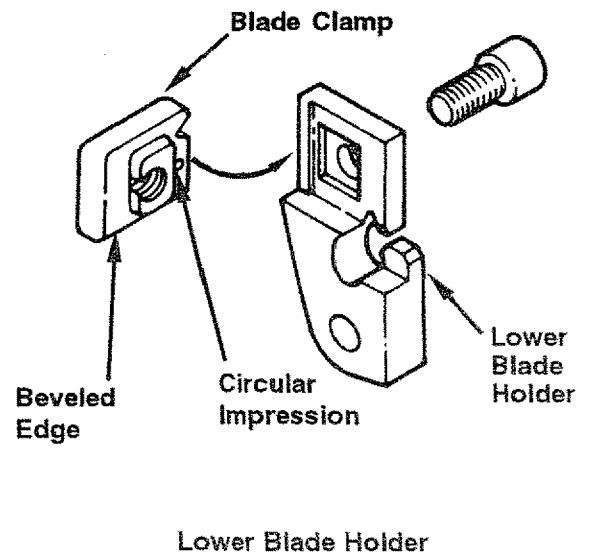
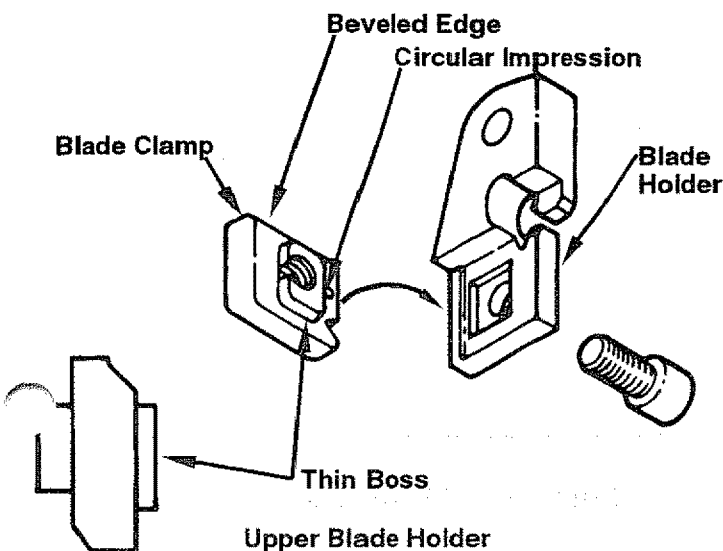
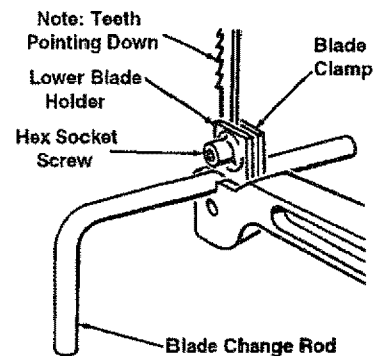
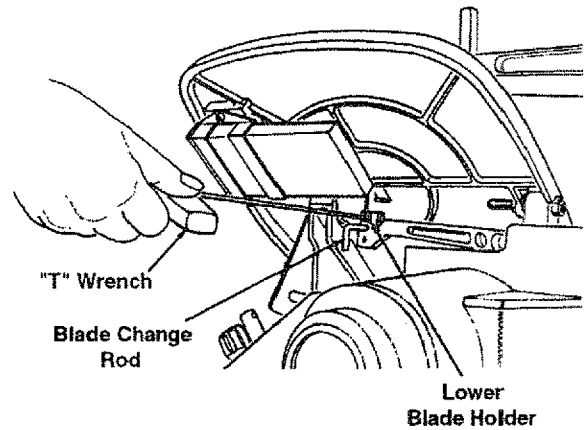
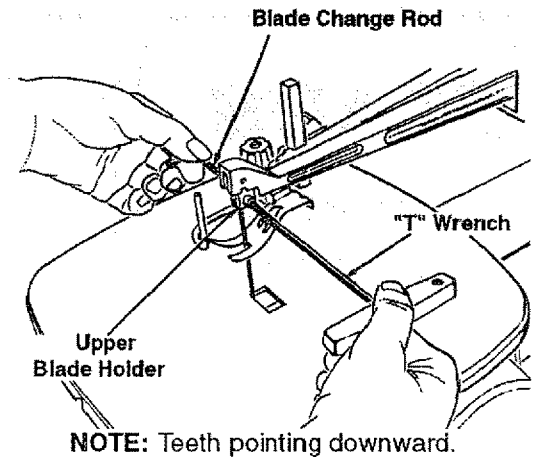

SEARS

**owner's
manual**

SERVICE

**MODEL NO.
113.236150**

**HOW TO ORDER
REPAIR PARTS**

**16 INCH VARIABLE
SPEED SCROLL SAW**

Now that you have purchased your scroll saw, should a need ever exist for repair parts or service, simply contact any Sears Service Center and most Sears, Roebuck and Co. stores. Be sure to provide all pertinent facts when you call or visit.

The model number of your scroll saw will be found attached to the right side of the arm housing.

WHEN ORDERING REPAIR PARTS, ALWAYS GIVE THE FOLLOWING INFORMATION:

PART NUMBER	PART DESCRIPTION
MODEL NUMBER 113.236150	NAME OF ITEM 16 INCH VARIABLE SPEED SCROLL SAW

All parts listed may be ordered from any Sears Service Center and most Sears stores. If the parts you need are not stocked locally, your order will be electronically transmitted to a Sears Repair Parts Distribution Center for handling.

Sold by SEARS, ROEBUCK AND CO., Chicago, Il. 60684 U.S.A.