

## Operator's Manual

# CRAFTSMAN<sup>®</sup>

**10 in. MiterMate™ MITER SAW  
WITH LASER TRAC<sup>®</sup>  
Model No. 137.212260**

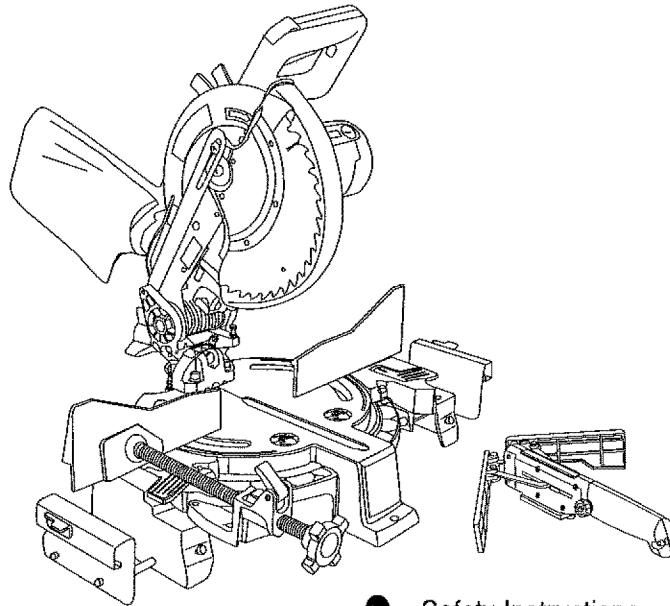

### CAUTION:

Before using this Miter Saw, read this manual and follow all its Safety Rules and Operating Instructions

- Safety Instructions
- Installation
- Operation
- Maintenance
- Parts List

**Customer Help Line  
For Technical Support  
1-800-843-1682**

**Sears Parts &  
Repair Center  
1-800-488-1222**

Sears, Roebuck and Co., Hoffman Estates, IL 60179 USA  
Visit our Craftsman website: [www.sears.com/craftsman](http://www.sears.com/craftsman)  
Part No. 137212260001

Printed in China

# TABLE OF CONTENTS

SECTION	PAGE
Warranty .....	2
Product Specifications .....	3
Symbols.....	4
Power Tool Safety .....	5
Compound Miter Saw Safety .....	7
Electrical Requirements and Safety.....	9
Accessories and Attachments .....	11
Tools Needed for Assembly .....	12
Carton Contents .....	13
Know Your MiterMate™ Miter Saw.....	14
Glossary of Terms .....	15
Assembly and Adjustments.....	17
Operation .....	25
Setting up the Tables for Angle Cuts Using the Angle Finder .....	32
Maintenance .....	38
Troubleshooting Guide .....	40
Parts List .....	41
Repair Protection Agreements .....	47

## WARRANTY

### CRAFTSMAN FULL WARRANTY

If this Craftsman product fails due to a manufacturer's defect in material or workmanship with one year from the date of purchase, return it to any Sears store or other Craftsman outlet in the United States for free replacement. This warranty does not include expendable parts such as saw blades which can wear out from normal use within the warranty period. This warranty applies for only 90 days from the date of purchase if this product is ever used for commercial or rental purposes. This warranty gives you special legal rights, and you may also have other rights which vary from state to state.

**Sears, Roebuck and Co., Hoffman Estates, IL 60179**

### WARNING

Some dust created by using power tools contains chemicals known to the state of California to cause cancer and birth defects or other reproductive harm. Some examples of these chemicals are:

- Lead from lead-based paints
- Crystalline silica from bricks, cement and other masonry products
- Arsenic and chromium from chemically treated lumber

Your risk from these exposures varies, depending on how often you do this type of work. To reduce your exposure to these chemicals, work in a well ventilated area and work with approved safety equipment such as dust masks that are specially designed to filter out microscopic particles.

# PRODUCT SPECIFICATIONS

## MOTOR

Power Source ..... 120V, 60Hz, 15A  
Speed ..... 4800RPM (No load)  
Brake ..... Electric  
Double Insulated ..... Yes

## BLADE SIZE

Diameter..... 10 in.  
Arbor size..... 5/8 in.

## ROTATING TABLE:

Diameter..... 12-3/4 in.  
Miter Detent Stops ..... 0°, 22.5°, 45° R & L  
Bevel Positive Stops ..... 0, 45° L

## CUTTING CAPACITY:

Crosscut ..... 2-5/8 in. x 5-9/16 in.  
Miter 45° R & L..... 2-5/8 in. x 3-1/2 in.  
Bevel 45° L..... 1-9/16 in. x 5-9/16 in.  
45° Miter and 45° Bevel..... 1-9/16 in. x 3-1/2 in.  
Crown Molding..... 4-1/4 in.

## WARNING

To avoid electrical hazards, fire hazards or damage to the tool, use proper circuit protection.

This tool is wired at the factory for 110-120 Volt operation. It must be connected to a 110-120 Volt / 15 Ampere time delay fuse or circuit breaker. To avoid shock or fire, replace power cord immediately if it is worn, cut or damaged in any way.

Before using your tool, it is critical that you read and understand these safety rules. Failure to follow these rules could result in serious injury to you or damage to the tool.

# SYMBOLS

## WARNING ICONS

Your power tool and its Operator's Manual may contain "WARNING ICONS" (a picture symbol intended to alert you to, and/or instruct you how to avoid, a potentially hazardous condition). Understanding and heeding these symbols will help you operate your tool better and safer. Shown below are some of the symbols you may see.



**SAFETY ALERT:** Precautions that involve your safety.



**PROHIBITION**



**WEAR EYE PROTECTION:** Always wear safety goggles or safety glasses with side shields.



**READ AND UNDERSTAND OPERATOR'S MANUAL:** To reduce the risk of injury, user and all bystanders must read and understand operator's manual before using this product.



**KEEP HANDS AWAY FROM BLADE:** Failure to keep your hands away from the blade will result in serious personal injury.



**SUPPORT AND CLAMP WORK**



**DANGER:** indicates an imminently hazardous situation which, if not avoided, will result in death or serious injury.



**WARNING:** indicates a potentially hazardous situation which, if not avoided, could result in death or serious injury.



**CAUTION:** indicates a potentially hazardous situation which, if not avoided, may result in minor or moderate injury.



**CAUTION:** used without the safety alert symbol indicates a potentially hazardous situation which, if not avoided, may result in property damage.



# POWER TOOL SAFETY

## GENERAL SAFETY INSTRUCTIONS BEFORE USING THIS POWER TOOL

Safety is a combination of common sense, staying alert and knowing how to use your power tool.

### CAUTION

To avoid mistakes that could cause serious injury, do not plug the tool in until you have read and understood the following.

-  **1. READ** and become familiar with the entire Operator's Manual. **LEARN** the tool's application, limitations and possible hazards.
- 2. KEEP GUARDS IN PLACE** and in working order.
- 3. REMOVE ADJUSTING KEYS AND WRENCHES.** Form the habit of checking to see that keys and adjusting wrenches are removed from the tool before turning ON.
- 4. KEEP WORK AREA CLEAN.** Cluttered areas and benches invite accidents.
- 5. DO NOT USE IN DANGEROUS ENVIRONMENTS.** Do not use power tools in damp locations, or expose them to rain or snow. Keep work area well lit.
- 6. KEEP CHILDREN AWAY.** All visitors and bystanders should be kept a safe distance from work area.
- 7. MAKE WORKSHOP CHILD PROOF** with padlocks, master switches or by removing starter keys.
- 8. DO NOT FORCE THE TOOL.** It will do the job better and safer at the rate for which it was designed.
- 9. USE THE RIGHT TOOL.** Do not force the tool or an attachment to do a job for which it was not designed.
- 10. USE PROPER EXTENSION CORDS.** Make sure your extension cord is in good condition. When using an extension cord, be sure to use one heavy enough to carry the current your product will draw. An undersized cord will result in a drop in line voltage and in loss of power which will cause the tool to overheat. The table on page 10 shows the correct size to use depending on cord length and nameplate ampere rating. If in doubt, use the next heavier gauge. The smaller the gauge number, the heavier the cord.
- 11. WEAR PROPER APPAREL.** Do not wear loose clothing, gloves, neckties, rings, bracelets or other jewelry which may get caught in moving parts. Nonslip footwear is recommended. Wear protective hair covering to contain long hair.
-  **12. ALWAYS WEAR EYE PROTECTION.** Any power tool can throw foreign objects into the eyes and could cause permanent eye damage. **ALWAYS** wear Safety Goggles (not glasses) that comply with ANSI Safety standard Z87.1. Everyday eyeglasses have only impact-resistant lenses. They **ARE NOT** safety glasses. Safety Goggles are available at sears.

**NOTE:** Glasses or goggles not in compliance with ANSI Z87.1 could seriously injure you when they break.

13. **WEAR A FACE MASK OR DUST MASK.** Sawing operation produces dust.

14.  **SECURE WORK.** Use clamps or a vise to hold work when practical. It is safer than using your hand and it frees both hands to operate the tool.

15. **DISCONNECT TOOLS FROM POWER SOURCE** before servicing, and when changing accessories such as blades, bits and cutters.

16. **REDUCE THE RISK OF UNINTENTIONAL STARTING.** Make sure switch is in the OFF position before plugging the tool in.

17. **USE RECOMMENDED ACCESSORIES.** Consult this Operator's Manual for recommended accessories. The use of improper accessories may cause risk of injury to yourself or others.

18. **NEVER STAND ON THE TOOL.** Serious injury could occur if the tool is tipped or if the cutting tool is unintentionally contacted.

19. **CHECK FOR DAMAGED PARTS.** Before further use of the tool, a guard or other part that is damaged should be carefully checked to determine that it will operate properly and perform its intended function – check for alignment of moving parts, binding of moving parts, breakage of parts, mounting

and any other conditions that may affect its operation. A guard or other part that is damaged should be properly repaired or replaced.

20. **NEVER LEAVE THE TOOL RUNNING UNATTENDED. TURN THE POWER "OFF".** Do not walk away from a running tool until the blade comes to a complete stop and the tool is unplugged from the power source.

21. **DO NOT OVERREACH.** Keep proper footing and balance at all times.

22. **MAINTAIN TOOLS WITH CARE.** Keep tools sharp and clean for best and safest performance. Follow instructions for lubricating and changing accessories.

23. **WARNING:** Dust generated from certain materials can be hazardous to your health. Always operate saw in well-ventilated area and provide for proper dust removal.

24.  **DANGER** People with electronic devices, such as pacemakers, should consult their physician(s) before using this product. Operation of electrical equipment in close proximity to a heart pacemaker could cause interference or failure of the pacemaker.

# COMPOUND MITER SAW SAFETY

## SPECIFIC SAFETY INSTRUCTIONS FOR THIS COMPOUND MITER SAW

1. **DO NOT USE THIN KERF BLADES** they can deflect and contact guard and can cause possible injury to the operator.
2. **DO NOT** operate the miter saw until it is completely assembled and installed according to these instructions.
3. **IF YOU ARE NOT** thoroughly familiar with the operation of miter saws, seek guidance from your supervisor, instructor or other qualified person.
4. **ALWAYS** hold the work firmly against the fence and table. **DO NOT** perform any operation free hand (use clamp wherever possible).
5. **KEEP HANDS** out of the path of the saw blade. If the workpiece you are cutting would cause your hands to be within 6 in. of the saw blade, the workpiece should be clamped in place before making the cut.
6. **BE SURE** the blade is sharp, runs freely and is free of vibration.
7. **ALLOW** the motor to come up to full speed before starting a cut.
8. **KEEP THE MOTOR AIR SLOTS CLEAN** and free of chips or dust.
9. **ALWAYS MAKE SURE** all handles are tight before cutting, even if the table is positioned in one of the positive stops.
10. **BE SURE** both the blade and the collar are clean and the arbor bolt is tightened securely.
11. **USE** only blade collars specified for your saw.
12. **NEVER** use blades larger in diameter than 10 inches.
13. **NEVER** apply lubricants to the blade when it is running.
14. **ALWAYS** check the blade for cracks or damage before operation. Replace a cracked or damaged blade immediately.
15. **NEVER** use blades recommended for operation at less than 5000 RPM.
16. **ALWAYS** keep the blade guards in place and use at all times.
17. **NEVER** reach around the saw blade.
18. **MAKE SURE** the blade is not contacting the workpiece before the switch is turned ON.
19. **IMPORTANT:** After completing the cut, release the trigger and wait for the blade to stop before returning the saw to the raised position.
20. **MAKE SURE** the blade has come to a complete stop before removing or securing the workpiece, changing the workpiece angle or changing the angle of the blade.

21. **NEVER** cut metals or masonry products with this tool. This miter saw is designed for use on wood and wood-like products.
22. **NEVER** cut small pieces. If the workpiece being cut would cause your hand or fingers to be within 6 in. of the saw blade the workpiece is too small.
23. **PROVIDE** adequate support to the sides of the saw table for long work pieces.
24. **NEVER** use the miter saw in an area with flammable liquids or gases.
25. **NEVER** use solvents to clean plastic parts. Solvents could possibly dissolve or otherwise damage the material.
26. **SHUT OFF** the power before servicing or adjusting the tool.
27. **DISCONNECT** the saw from the power source and clean the machine when finished using.
28. **MAKE SURE** the work area is clean before leaving the machine.
29. **SHOULD** any part of your miter saw be missing, damaged, or fail in any way, or any electrical component fail to perform properly, lock the switch and remove the plug from the power supply outlet. Replace missing, damaged, or failed parts before resuming operation.



## ELECTRICAL REQUIREMENTS AND SAFETY

### **⚠ WARNING**

#### **POWER SUPPLY AND MOTOR SPECIFICATIONS**

The AC motor used in this saw is a universal, nonreversible type. See "MOTOR" in the "PRODUCT SPECIFICATIONS" section on page 3.

### **⚠ WARNING**

**To avoid electrical hazards, fire hazards, or damage to the tool, use proper circuit protection. Your saw is wired at the factory for 120 V operation. Connect to a 120 V, 15A circuit and use a 15 A time delay fuse or circuit breaker. To avoid shock or fire, if power cord is worn or cut, or damaged in any way, have it replaced immediately.**

#### **DOUBLE INSULATED**

The power tool is double insulated to provide a double thickness of insulation between you and tool's electrical system. All exposed metal parts are isolated from the internal metal motor components with protecting insulation.

**Replacement parts** – When servicing, use only identical replacement parts.

**Polarized plugs** – This saw has a plug that looks like the one shown below:

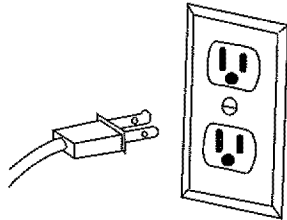

To reduce the risk of electrical shock, this saw has a polarized plug (one blade is wider than the other). This plug will fit in a polarized outlet only one

way. If the plug does not fit fully in the outlet, reverse the plug. If it still does not fit, contact a qualified electrician to install the proper outlet. Do not change the plug in any way.

### **⚠ WARNING**

Double insulation does not take the place of normal safety precautions when operating this tool.

#### **To avoid electrocution:**

1. Use only identical replacement parts when servicing a tool with double insulation. Servicing should be performed by a qualified technician.
2. Do not use power tools in wet or damp locations or expose them to rain or snow.

#### **MOTOR SAFETY PROTECTION IMPORTANT**

To avoid motor damage, the motor should be blown out or vacuumed frequently to keep sawdust from interfering with the motor ventilation.

1. **Connect** this saw to a 120 V circuit. This circuit must not be less than a #14 wire with a 15 A time lag fuse.  
**NOTE:** When using an extension cord on a circuit with a #14 wire, the extension cord must not exceed 25 feet in length.

2. If the motor will not start, release the trigger switch immediately.  
**UNPLUG THE SAW.** Check the saw blade to make sure it turns freely. If the blade is free, try to start the saw again. If the motor still does not start, refer to the **TROUBLESHOOTING GUIDE**.

3. If the tool suddenly stalls while cutting wood, release the trigger switch, unplug the tool and free the blade from the wood. The saw may

- now be started and the cut finished.
4. **FUSES** may "blow" or circuit breakers may trip frequently if:
    - a. **MOTOR** is overloaded.  
Overloading can occur if you feed too rapidly or make too many start/stops in a short time.
    - b. **LINE VOLTAGE** is more than 10% above or below the nameplate voltage rating.  
For heavy loads, the voltage at motor terminals must equal the voltage specified on the nameplate.
    - c. **IMPROPER** or dull saw blades are used.
  5. Most motor troubles may be traced to loose or incorrect connections, overload, low voltage or inadequate power supply wiring. Always check the connections, the load and supply circuit if the motor doesn't run well. Check minimum gauge for the length of cord you are using on the chart below.

extension cords from sharp objects, excessive heat and damp or wet areas.

**Use a separate electrical circuit for your tools.** This circuit must not be less than a #14 wire with a 15 A time lag fuse. **NOTE:** When using an extension cord on a circuit with a #14 wire, the extension cord must not exceed 25 feet in length. Before connecting the tool to the power line, make sure the switch is in the OFF position and the electric current is rated the same as the current stamped on the motor nameplate, running at a lower voltage will damage the motor.

MINIMUM GAUGE FOR EXTENSION CORDS (AWG)				
(When using 120 volts only)				
Ampere Rating		Total length of Cord		
More Than	Not More Than	25ft.	50ft.	100ft. 150ft.
0	6	18	16	16 14
6	10	18	16	14 12
10	12	16	16	14 12
12	16	14	12	Not Recommended

#### GUIDELINES FOR EXTENSION CORDS

Use a proper extension cord. Make sure your extension cord is in good condition. When using an extension cord, be sure to use one heavy enough to carry the current your product will draw. An undersized cord will cause a drop in line voltage, resulting in loss of power and overheating. The table below shows the correct size to use depending on cord length and nameplate ampere rating. If in doubt, use the next heavier gauge. The smaller the gauge number, the heavier the cord.

**Be sure your extension cord is properly wired** and in good condition. Always replace a damaged extension cord or have it repaired by a qualified person before using it. Protect your

**CAUTION: In all cases make certain the receptacle in question is properly grounded. If you are not sure, have a certified electrician check the receptacle.**

# ACCESSORIES AND ATTACHMENTS

## RECOMMENDED ACCESSORIES

### WARNING

- Use only accessories recommended for this miter saw. Follow instructions that accompany accessories. Use of improper accessories may cause hazards.
- The use of any cutting tool except 10 in. saw blades which meet the requirements under recommended accessories is prohibited. Do not use accessories such as shaper cutters or dado sets. Ferrous metal cutting and the use of abrasive wheels is prohibited.
- Do not attempt to modify this tool or create accessories not recommended for use with this tool. Any such alteration or modification is misuse and could result in a hazardous condition leading to possible serious injury.

### ACCESSORIES

Visit your Sears Hardware Department or see the Sears Power and Hand Tool Catalog to purchase recommended accessories for this power tool.

### WARNING

- To avoid the risk of personal injury, do not modify this power tool or use accessories not recommended by Sears.
- Read warnings and conditions on your CARBIDE TIPPED SAW BLADE. Do not operate the saw without the proper saw blade guard in place. Carbide is a very hard but brittle material. Care should be taken while mounting, using, and storing carbide tipped blades to prevent accidental damage. Slight shocks, such as striking the tip while handling, can seriously damage the blade. Foreign objects in the workpiece, such as wire or nails, can also cause tips to crack or break off. Before using, always visually examine the blade and tips for bent blade, cracks, breakage, missing or loose tips, or other damage. Do not use if damage is suspected. Failure to heed safety instructions and warnings can result in serious bodily injury.

# TOOLS NEEDED FOR ASSEMBLY

## Supplied



Blade Wrench

## Not supplied

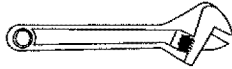

Adjustable Wrench



Phillips Screwdriver



Hex Wrench



Slotted Screwdriver

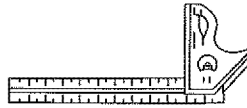

Combination Square

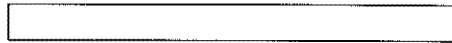

Square Bar

## COMBINATION SQUARE MUST BE TRUE

Should not gap or overlap when square is flipped over (see dotted figure).

Draw light line on board along this edge.

Straight edge or a 3/4 in. board, this edge must be perfectly straight.

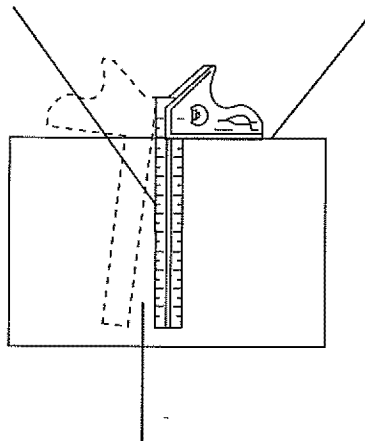

Should not gap or overlap when square flipped over (see dotted figure).

# CARTON CONTENTS

## UNPACKING YOUR MITER SAW

### **▲ WARNING**

To avoid injury from unexpected starting or electrical shock, do not plug the power cord into a source of power during unpacking and assembly. This cord must remain unplugged whenever you are working on the saw.

1. Remove the miter saw from the carton. **IMPORTANT:** Do not lift miter saw by the trigger switch handle. It may cause misalignment.
2. Place the saw on a secure stationary work surface.
3. Separate all parts from the packing material. Check each one with

the illustration to make certain all items are accounted for, before discarding any packing material.

### **▲ WARNING**

- If any part is missing or damaged, do not attempt to assemble the miter saw, or plug in the power cord until the missing or damaged part is correctly replaced. To avoid electric shock, use only identical replacement parts when servicing double insulated tools. Call 1-800-4-MY-HOME® for replacement parts.

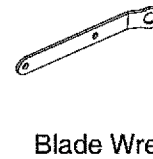
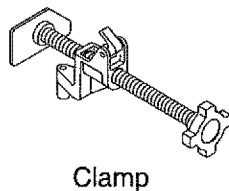
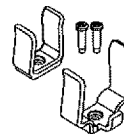
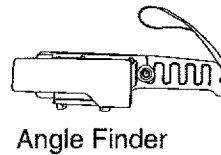
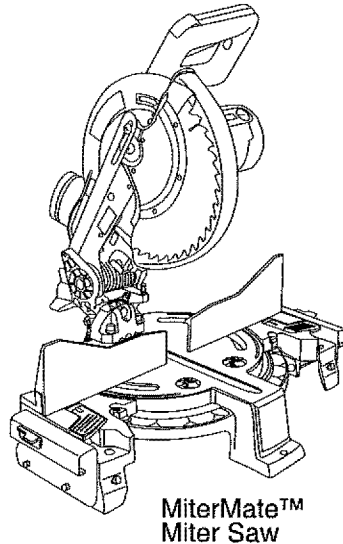

# KNOW YOUR MITERMATE™ MITER SAW

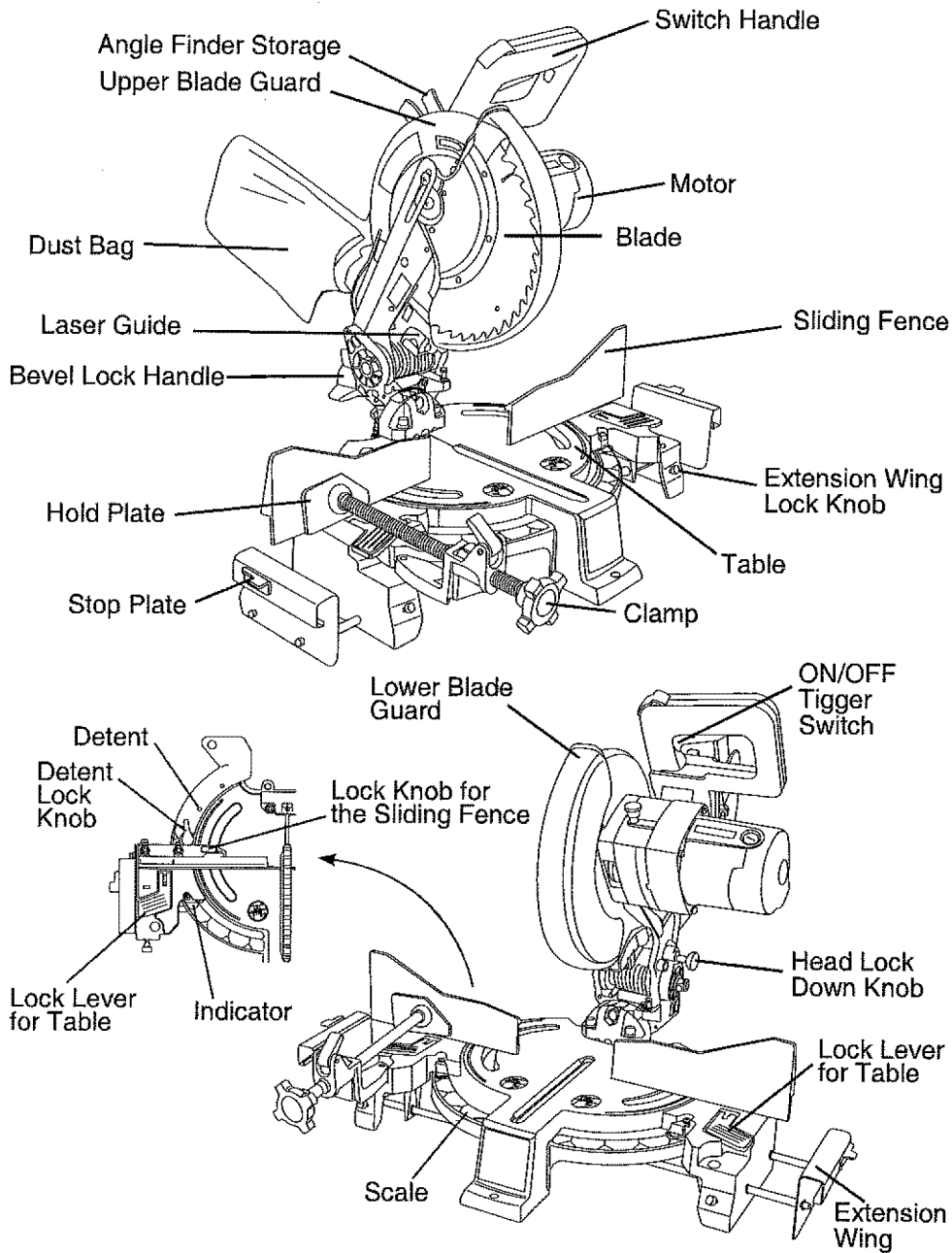

## GLOSSARY OF TERMS

**AMPERAGE (AMPS)** – A measure of the flow of electric current. Higher ratings generally means the tool is suited for heavier use.

**ANGLE FINDER STORAGE** – Convenient storage to prevent misplacing the angle finder.

**ARBOR LOCK** – Allows the user to keep the blade from rotating while tightening or loosening the arbor bolt during blade replacement or removal.

**BASE** – Supports the table, holds accessories and allows for workbench or leg set mounting.

**BEVEL LOCKING HANDLE** – Locks the miter saw at a desired bevel angle.

**BEVEL SCALE** – To measure the bevel angle of the saw blade 0° to 45° left.

**CARBIDE TIPPED** – Extremely hard steel pieces with sharp cutting edges fastened to cutting tools such as saw blades.

**CLAMP** – Secure the workpiece during performing cutting.

**COVER PLATE SCREW** – Loosen this screw and rotate the plate for access to the blade arbor bolt.

**DOUBLE-INSULATED** – A form of electrical protection featuring two separate insulation systems to help protect against electrical shock.

**DUAL MITER SCALE** – Each measures the miter angle 0° to 50° forward and backward.

**EXTENSION CORD** – An electric cord used between power tools and outlets to extend the range of the tools. The more amerage your tool uses, the longer the distance, the larger the size of the wire needed in your extension cord.

**EYE PROTECTION** – Goggles or spectacles intended to protect your eyes. Eye protection should meet the requirements of ANSI Z.87.1 (USA) or CSA Z94.3-M88 (Canada).

**FACE SHIELD** – An impact resistant shield that helps to protect your face from chips, sparks, small debris. Should only be used in conjunction with additional eye protection.

**FENCE** – Helps to keep the workpiece from moving when sawing. Scaled to assist with accurate cutting.

**GUARD** – Protective devise that forms a barrier between a hazardous object such as a blade, wheel or cutter and the operator.

**HEAD LOCK DOWN KNOB** – Locks the miter saw in the lowered position for compact storage and transportation.

**INSTRUCTION OR OPERATOR'S MANUAL** – Booklet accompanying your power tool that describes the hazards and safe operation procedures, outlines basic tool operation, care and maintenance.

**MOUNTING HOLES** – To mount the miter saw to a stable surface.

**ON/OFF TRIGGER SWITCH** – To start the tool, squeeze the trigger. Release the trigger to turn off the miter saw.

**POSITIVE STOP LOCKING LEVER** – Locks the miter saw at a preset positive stop for the desired miter angle.

**SWITCH HANDLE** – The switch handle contains the trigger switch and the laser on/off switch. The blade is lowered into the workpiece by pushing down on the handle. The saw will return to its upright position when the handle is released.

**WARNING LABELS** – Read and understand for your own safety. Make sure all labels are present on machine and legible.

**WRENCH STORAGE** – Convenient storage to prevent misplacing the blade wrench.

#### **WOODWORKING TERMS**

**ARBOR** – The shaft on which a blade is mounted.

**BEVEL CUT** – An angle cut made through the face of the workpiece.

**COMPOUND CUT** – An angled cut to both the edge and face of a board, most common use is with crown molding.

**CROSS CUT** – A cut which runs across the board perpendicular to the grain.

**FREEHAND** – Performing a cut without using a fence (guide), hold down or other proper device to prevent the workpiece from twisting during the cutting operation.

**HEEL** – Misalignment of the blade.

**KERF** – The width of a saw cut, determined by the thickness and set of the blade.

**KICKBACK** – Sudden and unintended movement of the tool or workpiece. It is typically caused by binding or pinching of the workpiece

**MITER CUT** – A miter is a type of joint where the two parts to be joined are cut at an angle, and typically the finished joint forms a 90-degree angle. Also commonly spelled “mitre”.

**REVOLUTIONS PER MINUTE (RPM)** – The number of turns completed by a spinning object in one minute.

**SAW BLADE PATH** – The area of the workpiece or table top directly in line with the travel of the blade or the part of the workpiece which will be cut.

**SET** – The distance between two saw blade tips, bent outward in opposite directions to each other. The further apart the tips are, the greater the set.

**WORKPIECE** – The wood being cut. The surfaces of a workpiece are commonly referred to as faces, ends and edges.



# ASSEMBLY AND ADJUSTMENTS

## **▲ WARNING**

To avoid injury from unexpected starting or electrical shock, do not plug the power cord into a source of power during unpacking and assembly. This cord must remain unplugged whenever you are working on the saw.

## **▲ WARNING**

To avoid injury and damage to the saw, transport or store the miter saw with the cutting head locked in the down position. Never use the head lock down knob to hold the cutting head in a down position for cutting operations.

### **CUTTING HEAD (FIG. A)**

#### **Raising the Cutting Head**

1. Push down slightly on the switch handle (1).
2. Pull out the head lock down knob (2) out of the locking hole (3).
3. Pull up the switch handle (1) to raise to the up position.

**FIG. A**

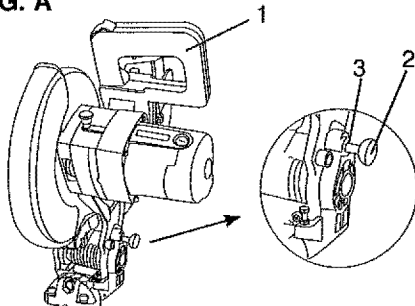

#### **Locking Cutting Head in Down Position (FIG. A)**

When transporting or storing the miter saw, the cutting head should always be locked in the down position.

1. Push the switch handle (1) down to its lowest position.

2. Push out the head lock down knob (2) into the locking hole (3).

**IMPORTANT:** To avoid damage, never carry the miter saw by the switch handle or the cutting arm.

### **INSTALLING THE DUST BAG (FIG. B)**

1. Squeeze the metal collar wings (2) of the dust bag (1).
2. Place the dust bag neck opening around the exhaust port (3), and release the metal collar wings.

**FIG. B**

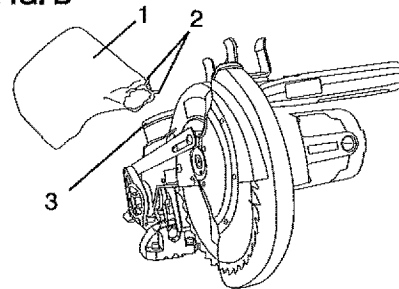

### **INSTALLING THE CLAMP (FIG. C)**

**NOTE:** The clamp is used to secure the workpiece during cutting operations.

1. Install the clamp on the saw by inserting the fixed shaft (1) into one of the holes (2) provided in the miter saw base.

**FIG. C**

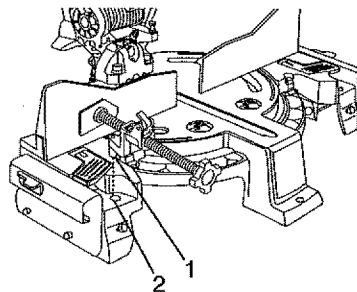

**STORING THE ANGLE FINDER  
(FIG. D)**

**Mounting the Storage Clips**

The storage clips are used to store the angle finder.

1. Install the wider storage clip (1) by threading the bolt (2) into the hole provided upon the rear end of the switch handle (3).
2. Install the narrower storage clip (4) by threading the bolt into the hole provided upon the front end of the switch handle.
3. Place the angle finder into the two storage clips for storage.

**FIG. D**

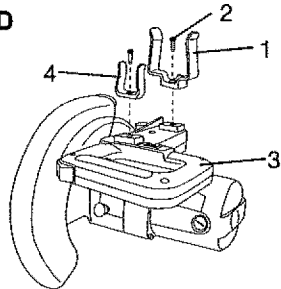

**Storing the MiterMate™ angle finder  
(Fig. D-1)**

4. Loosen the knob (5) on the MiterMate™ angle finder to fold up the paddles (6), then tighten the knob to lock the paddles.
5. Move and place the angle finder onto the storage clips (1) installed upon the switch handle for storage as shown.

**Fig. D-1**

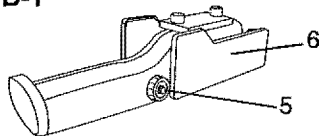

**SAW BLADE WRENCH (FIG. E)**

For convenient storage and prevention of loss, there is a slot (1) in the rear of the switch handle (2) for storing the blade wrench (3) when not in use.

**FIG. E**

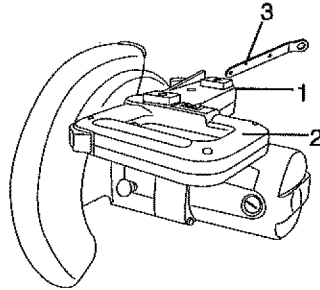

**REMOVING OR INSTALLING THE  
BLADE**

**▲ WARNING**

Only use a 10-inch diameter blade. To avoid injury from an accidental start, make sure the switch is in the OFF position and plug is not connected to the power source outlet.

**Removing Blade (Fig. F, G, H)**

1. Unplug the saw from the outlet.
2. Allow the cutting head to rise to the upright position. Raise the lower blade guard (1) to the up position. (Fig. F)
3. Loosen the cover plate screw (2) with a Phillips screwdriver.
4. Rotate the cover plate (3) towards the rear of the tool to expose the arbor bolt (4).
5. Place the blade wrench over the arbor bolt.

**Fig. F**

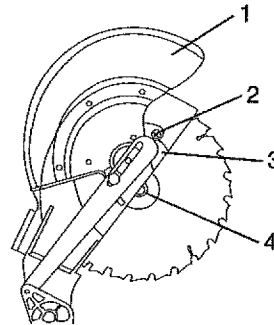

6. Locate the arbor lock (5) on the motor, below the switch handle. (Fig. G)
7. Press the arbor lock, holding it in firmly while turning the blade wrench clockwise. The arbor lock will engage after turning the wrench. Continue to hold the arbor lock in to keep it engaged, while turning the wrench clockwise to loosen the arbor bolt.

**Fig. G**

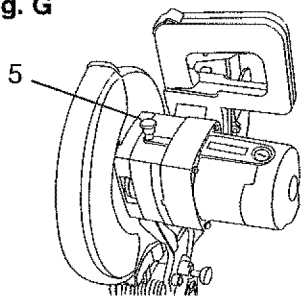

8. Remove the arbor bolt (8), outer blade collar (6), and the blade (7). Do not remove the inner blade collar. (Fig. H)

**NOTE:** Pay attention to the pieces removed, noting their position and direction they face. Wipe the blade collars clean of any sawdust before installing the new blade.

**Fig. H**

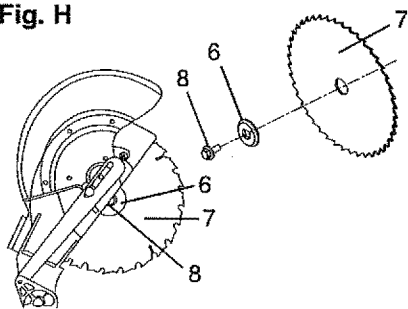

**Installing Blade (Fig. F, G, H)**

1. Install a 10 in. blade with a 5/8 in. arbor making sure the rotation arrow on the blade matches the clockwise rotation arrow on the upper guard, and the blade teeth are pointing downward.

2. Place the blade collar (6) against the blade and on the arbor. Thread the arbor bolt (8) onto the arbor in a counterclockwise direction. (Fig. H) **IMPORTANT:** Make sure the flats of the blade collars are engaged with the flats on the arbor shaft. Also, the flat side of the blade collar must be placed against the blade.
3. Place the blade wrench on the arbor bolt.
4. Press the arbor lock (5), holding it in firmly while turning the blade counterclockwise. When arbor lock engages, continue to press it in while tightening the arbor bolt securely. (Fig. G)
5. Rotate the cover plate (3) back to its original position until the slot in the cover plate engages with the cover plate screw (2). While holding the lower blade guard, tighten the screw with a Phillips screwdriver. (Fig. F) **NOTE:** The lower blade guard must be raised to the upright position to access the cover plate screw.
6. Lower the blade guard (1) and verify that the operation of the guard does not bind or stick.
7. Be sure the arbor lock is released so the blade turns freely.

**▲ WARNING**

- To avoid injury, never use the saw without the cover plate secure in place. It keeps the arbor bolt from falling out if it accidentally loosens, and helps prevent the spinning blade from coming off the saw.
- Make sure the collars are clean and properly arranged. Lower the blade into the table and check for any contact with the metal base or the turn table.

**MOUNTING THE MITER SAW  
(FIG. I, J, K)**

**⚠ WARNING**

**To avoid injury from unexpected saw movement:**

- Before moving the saw, disconnect the power cord from the outlet, and lock the cutting arm in the lower position using the head lock down knob.

**NOTE:** The head lock down knob is for carrying or storing the tool. It is not to be used for holding the saw while cutting. Lower blade and press in head lock down knob to secure saw for transport or storage.

- Never carry the miter saw by the power cord or by the switch handle. Carrying the tool by the power cord could cause damage to the insulation or wire connections resulting in electric shock or fire.
- To avoid injury from flying debris, do not allow visitors to stand behind the saw.
- Place the saw on a firm, level work-surface where there is room for handling and properly supporting the workpiece.
- Support the saw on a level work surface.
- Bolt or clamp the saw to its support.

Place the saw in the desired location, either on a work bench or recommended leg set. The base of the saw has three mounting holes (10). (Fig. J)

**Mounting instructions:**

1. **For stationary use**, place the saw in the desired location, directly on a workbench where there is room for handling and proper support of the workpiece. The base of the saw has three mounting holes. Bolt the base of the miter saw (1) to the work surface (5), using the fastening method as shown in Fig. I.

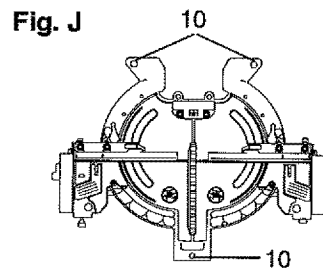
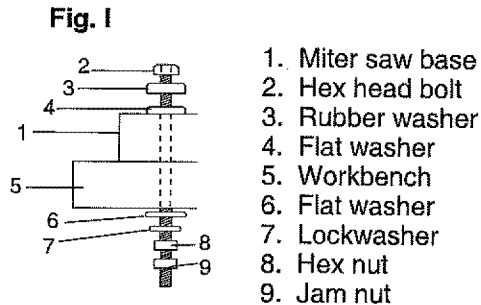

**NOTE:** Mounting hardware is not included with this tool. Bolts, nuts, washers, and screws must be purchased separately.

2. **For portable use**, place the saw on a 3/4 in. thick piece of plywood. Bolt the base of the miter saw securely to the plywood using the mounting holes on the base. Use C-clamps to clamp this mounting board to a stable work surface at the worksite.

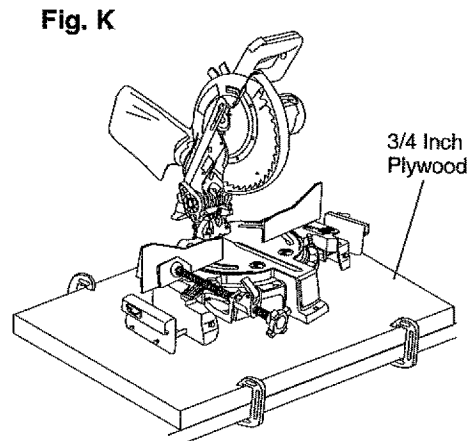

## ADJUSTMENT INSTRUCTIONS

### **▲ WARNING**

To avoid injury from an accidental start, make sure the switch is in the OFF position and the plug is not connected to the power source outlet.

### BEVEL STOP ADJUSTMENT (FIG. L, M, N)

### **▲ WARNING**

To avoid injury from unexpected starting or electrical shock, make sure the trigger is released and remove the power cord from the power source.

#### 90° Bevel Adjustment (Fig. L, M)

1. Loosen bevel lock handle (1) and tilt the cutting arm completely to the right. Tighten the bevel lock handle. Lower blade.
2. Place a combination square (2) on the miter table with the rule against the table and the heel of the square against the saw blade.
3. If the blade is not 90° square with the miter table, loosen the bevel lock handle, tilt the cutting head completely to the left, loosen the locknut (4) on the bevel angle adjustment bolt (3) and use a wrench to adjust the bolt (3) in or out to increase or decrease the bevel angle.
4. Tilt the cutting arm to back to the right at 90° bevel and recheck for alignment.
5. Repeat steps 1 through 4 if further adjustment is needed.
6. Tighten bevel lock handle and locknut (4) when alignment is achieved.

Fig. L

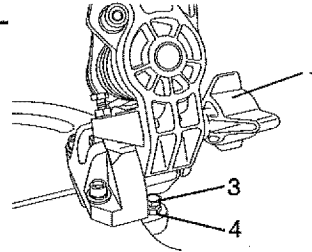
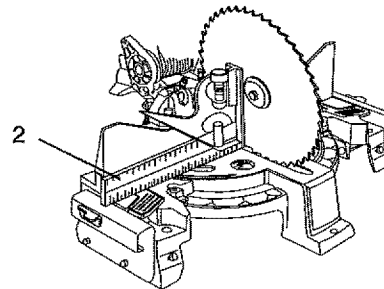

Fig.M

**NOTE:** The upper blade guard has been removed from this drawing for illustration purposes only. Never remove the upper blade guard.



#### 90° Bevel Indicator (Fig. N)

1. When the blade is exactly 90° to the table, loosen the bevel indicator screw (5) using a #2 Phillips screwdriver.
2. Adjust bevel indicator (6) to the "0°" mark (7) on the bevel scale and retighten the screw.

Fig. N

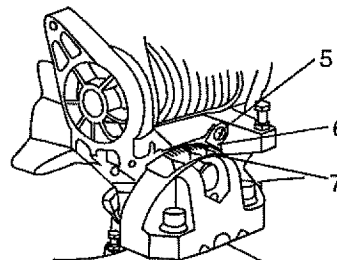

### 45° Bevel Adjustment (Fig. O)

1. Unlock the bevel lock handle (1) and tilt the cutting arm as far to the left as possible.
2. Using a combination square, check to see if the blade angle is 45° to the table.
3. If the blade is not at 45° to the miter table, tilt the cutting arm to the right, loosen the locknut (5) on the bevel angle adjustment bolt (4) and use a wrench to adjust the bolt (4) in or out to increase or decrease the bevel angle.
4. Tilt the cutting arm to the left to 45° bevel and recheck for alignment.
5. Repeat steps 1 through 4 until the blade is at 45° to the miter table.
6. Tighten bevel lock handle and locknut (5) when alignment is achieved.

**NOTE:** For avoiding the interference caused by the left sliding fence unit during adjustment, slide the plate leftward and tighten the knob.

**Fig. O**

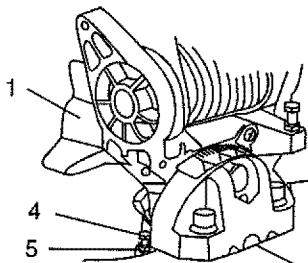

### MITER ANGLE ADJUSTMENT (FIG. P)

**NOTE:** There are dual miter scales on the miter saw. Each of the miter scales assists the user in setting the desired miter angle from 50° forward to 50° backward. Each sliding table has most common angle settings with positive stops at 45°, 22.5° and 0°. These positive stops position the sliding fence unit at the desired angle quickly and accurately.

### To adjust the angle:

1. Unlock the left sliding fence unit by unlocking the positive stop lock lever (1) behind the sliding fence unit and lifting up the lock lever (2) pivotally connected in the base.
2. Slide the left sliding fence unit forward or backward to the desired angle.
3. If the desired angle is one of the five detents (6), lock the positive stop lock lever, and then flip the lock lever down to lock the left sliding fence unit.
4. If the desired angle is not one of the five positive stops, simply lock the left sliding fence unit by flipping the lock lever down.
5. Adjust the angle of the right sliding fence unit according to the procedure foregoing 1-4.

### To adjust the indicator:

1. Position the left sliding fence unit at the positive stop angle 0° (refer to the procedure of To adjust the angle), loosen the bolt (3) and adjust the indicator (4) to aim at the 0° mark on the miter scale (5).
2. Adjust the indicator mounted on the right sliding fence unit according to the same way mentioned above.

**Fig. P**

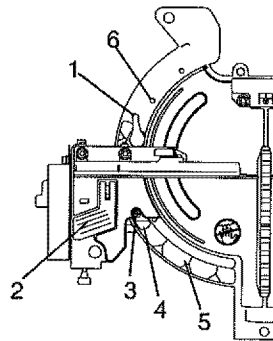

**ADJUSTING SLIDING FENCE UNITS  
SQUARENESS AND ALIGNMENT  
(FIG. Q, R, S)**

1. Lower the cutting arm and lock in position.
2. Using a square, lay the heel of the square against the worktable, and the rule against the blade. Check to see if the angle between the worktable and the blade is  $90^\circ$ .
3. If not, make the angle to be  $90^\circ$  by adjusting the bevel angle adjustment bolt (1).

**Fig. Q**

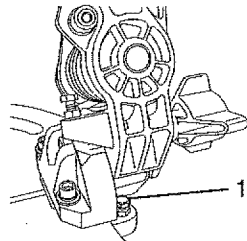

4. Lay the heel of the square against the blade, and the rule against the left sliding fence unit (2) which is positioned at positive stop angle  $0^\circ$ . Check to see if the angle between the blade and the left sliding fence unit is  $90^\circ$ .
5. If not, unlock the left sliding fence plate (3) by using a hex key to loosen the three bolts (4) behind the left sliding fence and two set screws (5) vertically placed on the lateral side of fence plate.
6. Adjust the left sliding fence plate (3) to be perpendicular to the blade, and then tighten the bolts (4) and screws (5) to lock the plate.

**Fig. R**

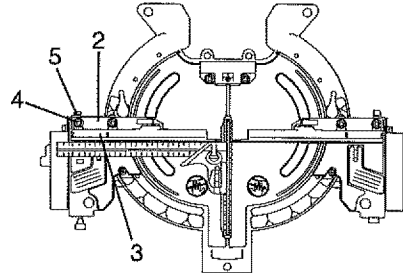

7. Using a bar (6), lay the bar against the left sliding fence unit (2) and the right sliding fence unit (7) which is also positioned at angle  $0^\circ$ , and check to see if the left and right sliding fence units are aligned on a same line.

**Fig. S**

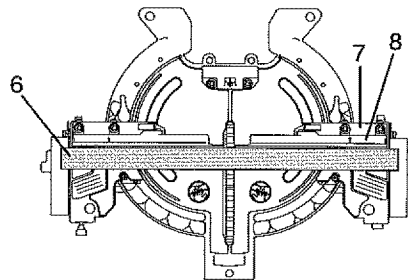

8. If not, unlock the right sliding fence plate (8) by using the hex key to loosen the three bolts (4) behind right sliding fence plate and two set screws (5) vertically placed on the lateral side of fence plate.
9. Adjust the right sliding fence plate (8) into alignment with the left sliding fence plate (3), and then tighten the bolts (4) and screws (5) to lock the right sliding fence plate.

### ADJUSTING LOCK LEVERS (FIG. T)

After a period of use, the lock levers might loosen and couldn't clamp the sliding fence units tightly.

An adjustment is needed.

1. Slightly lift up the miter saw base, find out the location of lock nuts (1) for both sides of lock levers. Properly tighten the lock nuts and slightly lay down the miter saw base.

**NOTE:** The adjustment of lock levers have been completed at the factory.

Fig. T

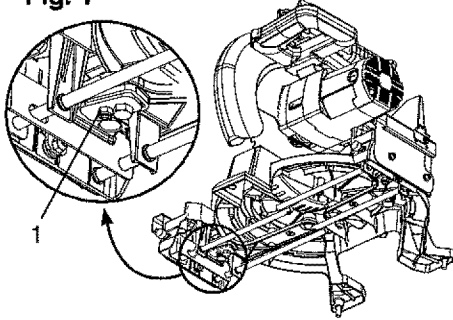

### CUTTING ARM TRAVEL Cutting Arm Downward Travel Adjustment (Fig. U)

#### **WARNING**

To avoid injury from unexpected starting or electrical shock, turn the switch OFF and remove the power cord from the power source.

**NOTE:** Before each cutting operation, check the position of the blade to make sure it does not contact any metal surface. If the blade contacts any metal surface, the depth of travel must be adjusted.

1. Lower the blade as far as possible.
2. Loosen the locknut (1).
3. Turn the adjustment bolt (2) out (counterclockwise) to decrease the cutting depth or in (clockwise) to increase the cutting depth.
4. Carefully rotate the blade manually to check for contact. Avoid touching blade points or edges.

5. Repeat until adjusted properly, and tighten the locknut to secure the adjustment bolt into position.

Fig. U

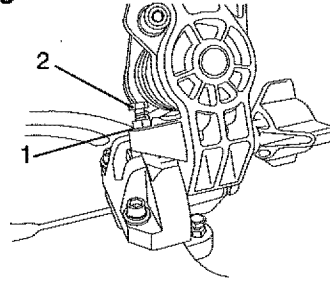

### ADJUSTING THE CLAMP (FIG. V)

1. Rotate the knob (1) counterclockwise to allow enough room for the workpiece to fit between the hold plate (2) and the sliding fence unit.
2. The clamp incorporates a quick-release lock lever (3). To use the quick-release function, lift up the quick-release lock lever and slide the clamp forward or backward to the desired position.
3. When the clamp plate is located at the desired position, flip the quick-release lock lever down to engage the threads thereon with the threads on the clamp, and rotate the knob clockwise to secure the workpiece within the hold plate and the sliding fence unit.

**NOTE:** If intend to release the workpiece from secure status, counterclockwise the knob first before lifting up the quick-release lock lever.

Fig. V

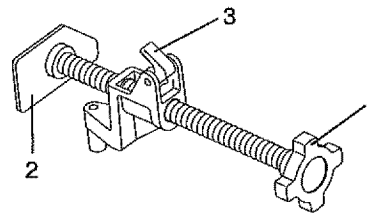



## OPERATION

### SAFETY INSTRUCTIONS FOR BASIC SAW OPERATION

#### BEFORE USING THE MITER SAW

#### WARNING

To avoid mistakes that could cause serious, permanent injury, do not plug the tool in until the following steps are completed:

- Completely assemble and adjust the saw, following the instructions. **(ASSEMBLY AND ADJUSTMENTS)**
- Learn the use and function of the ON/OFF switch, lock-off switch, upper and lower blade guards, head lock down knob, bevel lock handle and cover plate screws.
- Review and understand all safety instructions and operating procedures in this Operator's Manual. **(SAFETY & OPERATIONS)**
- Review the **MAINTENANCE** and **TROUBLESHOOTING GUIDE** for your miter saw.
- To avoid injury or possible death from electrical shock:  
Make sure your fingers do not touch the plug's metal prongs when plugging or unplugging your miter saw. **(ELECTRICAL REQUIREMENTS AND SAFETY)**

#### BEFORE EACH USE INSPECT YOUR SAW.

- **Disconnect the miter saw.**  
To avoid injury from accidental starting, unplug the saw before any adjustments, including set-up and blade changes.
- **Compare the direction of rotation arrow** on the guard to the direction arrow on the blade. The blade teeth should always point downward at the front of the saw.

- **Tighten the arbor bolt.**
- **Tighten the cover plate screw.**
- **Check for damaged parts.**

Check for:

- Alignment of moving parts
- Damaged electric cords
- Binding of moving parts
- Mounting holes
- Function of arm return spring and lower guard: Push the cutting arm all the way down, then let it rise until it stops. The lower guard should fully close. Follow instructions in **TROUBLESHOOTING GUIDE** for adjustment if necessary.
- Other conditions that may affect the way the miter saw works.
- Keep all guards in place, in working order and proper adjustment. If any part of this miter saw is missing, bent, damaged or broken in any way, or any electrical parts don't work, turn the saw off and unplug it.
- Replace bent, damaged, missing or defective parts before using the saw again.
- Maintain tools with care. Keep the miter saw clean for best and safest performance. Follow instructions for lubricating. Do not put lubricants on the blade while it is spinning.
- Remove adjusting wrench from the tool before turning it on.
- To avoid injury from jams, slips, or thrown pieces, use only recommended accessories.
- Check the dust bag before you work. Empty the bag if it is more than half-full.

#### RECOMMENDED ACCESSORIES

- Consult the **ACCESSORIES** and **ATTACHMENTS** section of this Operator's Manual for recommended

accessories. Follow the instructions that come with the accessory. The use of improper accessories may cause risk of injury to persons.

- Choose the correct 10 in. diameter blade for the material and the type of cutting you plan to do. Do not use thin kerf blades.
- Make sure the blade is sharp, undamaged and properly aligned. With the saw unplugged, push the cutting arm all the way down. Manually spin the blade and check for clearance. Tilt the power-head to a 45° bevel and repeat the test.
- Make sure the blade and arbor collars are clean.
- Make sure all clamps and locks are tight and there is no excessive play in any parts.

#### **KEEP YOUR WORK AREA CLEAN**

Cluttered areas and benches invite accidents.

#### **▲ WARNING**

**To avoid burns or other fire damage, never use the miter saw near flammable liquids, vapors, or gases.**

- Plan ahead to protect your eyes, hands, face and ears.
- Know your miter saw. Read and understand this Operator's Manual and labels affixed to this tool. Learn its application and limitations as well as the specific potential hazards peculiar to this tool. To avoid injury from accidental contact with moving parts, do not do layout, assembly, or setup work on the miter saw while any parts are moving.
- Avoid accidental starting, make sure the trigger switch is disengaged before plugging the miter saw into a power outlet.

#### **PLAN YOUR WORK**

- Use the right tool. Don't force a tool or attachment to do a job it was not

designed to do. Use a different tool for any workpiece that can't be held in a solidly braced, fixed position.

#### **▲ CAUTION**

**This machine is not designed for cutting masonry, masonry products, ferrous metals (steel, iron, and iron-based metals.) Use this miter saw to cut only wood, wood-like products, or non-ferrous metals. Other material may shatter, bind the blade, or create other dangers. Remove all nails that may be in the workpiece to prevent sparking that could cause a fire. Remove dust bag when cutting non-ferrous metals.**

#### **DRESS FOR SAFETY**



Any power tool can throw foreign objects into the eyes. This can result in permanent eye damage. Everyday eyeglasses have only impact resistant lenses and are not safety glasses. Glasses or goggles not in compliance with ANSI Z87.1 could seriously injure you when they break.

- Do not wear loose clothing, gloves, neckties or jewelry (rings, watches). They can get caught and draw you into moving parts.
- Wear non-slip footwear.
- Tie back long hair.
- Roll long sleeves above the elbow.
- Noise levels vary widely. To avoid possible hearing damage, wear ear plugs when using any miter saw.
- For dusty operations, wear a dust mask along with safety goggles.

#### **INSPECT YOUR WORKPIECE**

Make sure there are no nails or foreign objects in the part of the workpiece being cut.

Plan your work to avoid small pieces that may bind, or that are too small to clamp and get a solid grasp on.

Plan the way you will grasp the workpiece from start to finish. Avoid awkward operations and hand positions. A sudden slip could cause your fingers or hand to move into the blade.

#### **DO NOT OVER-REACH**

Keep good footing and balance. Keep your face and body to one side, out of the line of a possible kickback. NEVER stand in the line of the blade.

#### **Never cut freehand:**

- Brace your workpiece firmly against the fence and table stop so it will not rock or twist during the cut.
- Make sure there is no debris between the workpiece and the table or fence.
- Make sure there are no gaps between the workpiece, fence and table that will let the workpiece shift after it is cut.
- Keep the cut off piece free to move sideways after it is cut off. Otherwise, it could get wedged against the blade and thrown violently.
- Only the workpiece should be on the saw table.
- Secure work. Use clamps or a vise to help hold the work when it's practical.

#### **USE EXTRA CAUTION WITH LARGE OR ODD SHAPED WORKPIECES.**

- Use extra supports (tables, sawhorses, blocks, etc.) for workpieces large enough to tip.
- Never use another person as a substitute for a table extension, or as an additional support for a workpiece that is longer or wider than the basic miter saw table, or to help feed, support, or pull the workpiece.
- Do not use this saw to cut small pieces. If the workpiece being cut would cause your hand or fingers to

be within 6 inches of the saw blade the workpiece is too small. Keep hands and fingers out of the "no hands zone" area marked on the saw table.

- When cutting odd shaped workpieces, plan your work so it will not bind in the blade and cause possible injury. Molding, for example, must lie flat or be held by a fixture or jig that will not let it move when cut.
- Properly support round material such as dowel rods, or tubing, which have a tendency to roll when cut, causing the blade to "bite".

#### **▲ WARNING**

**To avoid injury, follow all applicable safety instructions, when cutting non-ferrous metals:**

- Use only saw blades specifically recommended for non-ferrous metal cutting.
- Do not cut metal workpieces that must be hand held. Clamp workpieces securely.
- Cut non-ferrous metals only if you are under the supervision of an experienced person and the dust bag has been removed from the saw.

#### **WHEN SAW IS RUNNING**

#### **▲ WARNING**

**Do not allow familiarity from frequent use of your miter saw to result in a careless mistake. A careless fraction of a second is enough to cause a severe injury.**

**Before cutting, if the saw makes an unfamiliar noise or vibrates, stop immediately. Turn the saw OFF. Unplug the saw. Do not restart until finding and correcting the problem.**

## BODY AND HAND POSITION (FIG. W)

### **▲ WARNING**



Never place hands near the cutting area. Proper positioning of your body and hands when operating the miter saw will make cutting easier and safer. Keep children away. Keep all visitors at a safe distance from the miter saw. Make sure bystanders are clear of the saw and workpiece. Don't force the saw. It will do the job better and safer at its designed rate.

#### Starting a cut:

- Place hands at least 6 in. away from the path of the blade – out of the “no-hands zone” (1).
- Hold workpiece firmly against the fence to prevent movement toward the blade.
- With the power switch OFF, bring the saw blade down to the workpiece to see the cutting path of the blade.
- Press in lock-off switch in trigger switch handle.
- Squeeze trigger switch to start saw.
- Lower blade into workpiece with a firm downward motion.

#### Finishing a cut:

- Hold the cutting arm in the down position.
- Release trigger switch and wait for all moving parts to stop before moving your hands and raising the cutting arm.
- If the blade doesn't stop within 6 seconds, unplug the saw and follow the instructions in TROUBLESHOOTING GUIDE section.

#### Before freeing jammed material:

- Release trigger switch.
- Wait for all moving parts to stop.
- Unplug the miter saw.

Fig. W

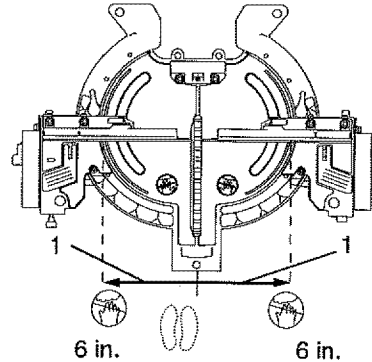

## BASIC SAW OPERATIONS

### **▲ WARNING**

For your convenience, your saw has a blade brake. The brake is not a safety device. Never rely on it to replace the proper use of the guard on your saw. If the blade doesn't stop within approximately 10 seconds, wait for the blade to stop, unplug the saw and contact Sear Service Center.

#### THE LASER GUIDE (FIG. X, Y)

1. To turn laser on, turn switch (1) to “I” position.
2. To turn laser off, turn switch to “O” position.

Fig. X

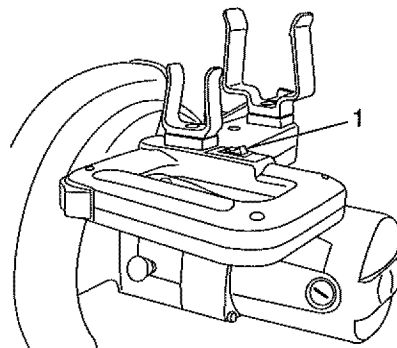

**NOTE:**

- All the adjustments for the operation of the laser guide has been completed at the factory.
- Laser beam is calibrated and set up to project to the left of the blade. (Fig. Y)
- If you have any problem or question on the laser guide, please call the Sears Service Center.

**Fig. Y**

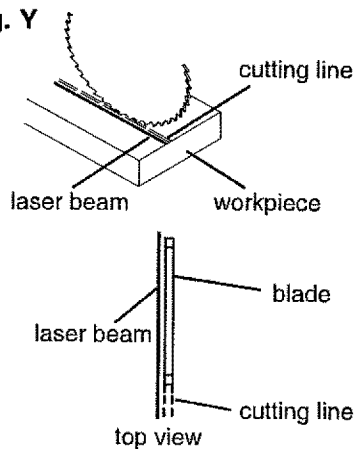

**AVOID DIRECT EYE CONTACT**

**▲ WARNING**

- Laser is radiated when laser guide is turned on. Avoid direct eye contact. Always un-plug the miter saw from power source before making any adjustments.

**▲ DANGER**

- Laser Warning Label:  
Max output < 5 mW DIODE  
Wavelength: 630-660nm,  
Complies with 21CFR 1040.10 and 1040.11.

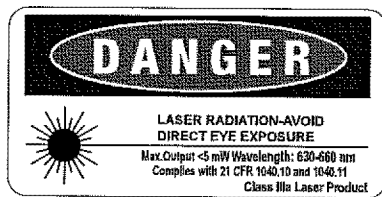

**(Fig. Z)**

- Laser Aperture Label:  
**AVOID EXPOSURE: Laser radiation is emitted from this aperture. (Fig. Z)**



**▲ WARNING**

- Use of controls or adjustments or performance of procedures other than those specified herein may result in hazardous radiation exposure.

**▲ WARNING**

- The use of optical instruments with this product will increase eye hazard.
- Do not attempt to repair or disassemble the laser. If unqualified persons attempt to repair this laser product, serious injury may result. Any repair required on this laser product should be performed by a Sears or other qualified service center.

**NOTE:** All the adjustments for the operation of this machine have been completed at the factory.

**Fig. Z**

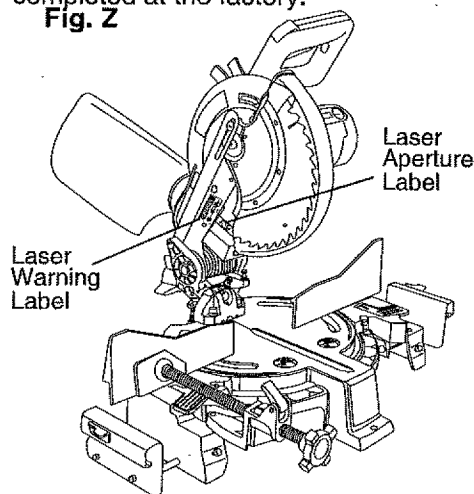

### TURNING SAW ON (FIG. AA)

To reduce the likelihood of accidental starting, a thumb activated lock-OFF switch is located on top of the switch handle. The lock-OFF switch (1) must be pushed in before the trigger switch (2) can be activated and the miter saw started.

#### **WARNING**

Make the switch child-proof. Insert a padlock through the hole (3) in the trigger switch and lock it. This will prevent children and other unauthorized users from engaging the trigger switch ON.

Fig. AA

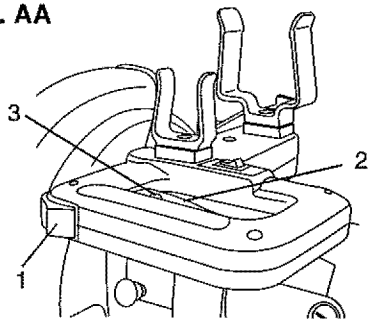

### BEFORE LEAVING THE SAW

- Never leave tool running unattended. Turn power OFF. Wait for all moving parts to stop and unplug unit from power source.
- Make workshop child-proof. Lock the shop. Disconnect master switches. Store tool away from children and other unqualified users.

#### **WARNING**

To avoid injury from materials being thrown, always unplug the saw to avoid accidental starting, and remove small pieces of material from the table cavity.

### MITER CUT (FIG. BB, BB-1)

1. Choose the left or right sliding fence unit to perform the miter cutting.

2. If the left sliding fence unit (1) is chosen, unlock the left sliding fence unit by unlocking the positive stop lock lever (2) behind the left sliding fence unit and lifting up the lock lever (3) pivotally connected in the base.

Fig. BB

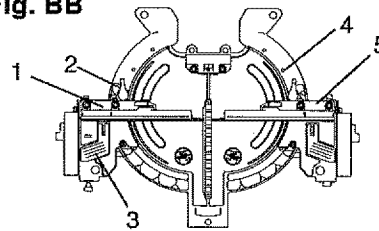

3. Slide the left sliding fence unit to the desired angle from 0° to 50° forward.
4. If the desired angle is one of the positive stops (4), engage the positive stop lock lever, and then flip the lock lever down to lock the sliding fence unit. Positive stops for miter cutting are provided at 0°, 22.5° and 45°.
5. If the desired angle is not one of positive stops, simply lock the sliding fence unit by flipping the lock lever down.
6. For avoiding the interference caused by the right sliding fence unit (5) during cutting operation, lock the right sliding fence at the angle 45° forward.
7. Unlock the right sliding fence plate by loosening the knob, and slide the right sliding fence plate rightward to the distal end, and tighten the knob.
8. Place the workpiece against the left sliding fence unit and secure the workpiece by the vise to perform the miter cutting.
9. If the right sliding fence unit is chosen, inversely adjust the two sliding fence units according to the procedure foregoing 2-8.

**IMPORTANT:** Make sure both sliding fences are secure and tight before beginning any cutting operation.

**IMPORTANT:** Make sure that both sides of the sliding fences are positioned so that they do not contact the saw blade. Check this before plugging in and starting the saw. Secure and Lock into position before making any cutting operations.

**Fig. BB-1**

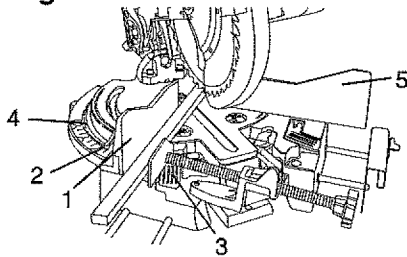

**BEVEL CUT (FIG. CC)**

1. When a bevel cut is required, loosen the bevel lock handle for angle adjusting.
2. Tilt the cutting head to the desired angle as shown on the bevel scale (1). The blade can be positioned at any angle, from a 90° straight cut (0° on the scale) to a 45° left bevel.
3. Unlock the left sliding fence plate by loosening the knob, and slide the plate leftward for avoiding interference, and tighten the knob.
4. Tighten the bevel lock handle to lock the cutting head in position.
5. Positive stops are provided at 0° and 45°.

**IMPORTANT:** Make sure both sliding fences are secure and tight before beginning any cutting operation.

**Fig. CC**

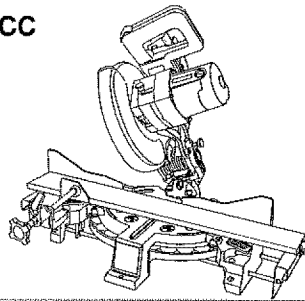

**COMPOUND CUT (FIG. DD)**

A compound cut is the combination of a miter and a bevel cut simultaneously.

1. Unlock the left sliding fence unit by unlocking the positive stop lock lever behind the left sliding fence unit and lifting up the lock lever pivotally connected in the base.
2. Slide the left sliding fence unit to the desired angle from 0°~ 50° forward.
3. If the desired angle is one of the positive stops, tighten the positive stop lock lever, and then flip the lock lever down to lock the sliding fence unit. Positive stops for compound cutting are provided at 0°, 22.5° and 45°.
4. If the desired angle is not one of positive stops, simply lock the sliding fence unit by flipping the lock lever down.
5. Unlock the left sliding fence plate by loosening the knob, and slide the left sliding fence plate leftward for avoiding interference, and tighten the knob.
6. Lock the right sliding fence at the angle 45° forward, loosen the knob, and slide the right sliding fence plate rightward to the distal end for avoiding interference, then tighten the knob.
7. Loosen the bevel lock handle and position the cutting head at the desired bevel angle which can be read from the bevel scale, and then tighten the bevel lock handle.
8. Place the workpiece against the left sliding fence plate and secure the workpiece by the vise to perform the compound cutting.

**IMPORTANT:** Make sure both sliding fences are secure and tight before beginning any cutting operation.

**Fig. DD**

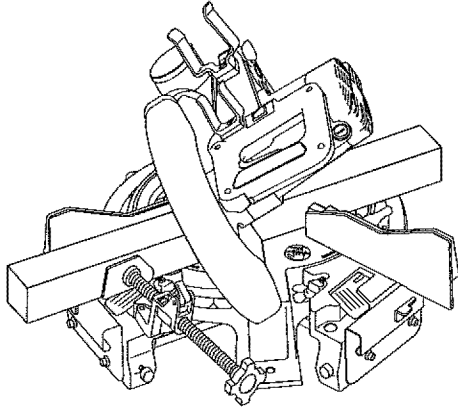

**WORKPIECE SUPPORT AND REPETITIVE CUTTING USING THE STOP PLATE (FIG. EE)**

Long workpieces need to be supported by the extension wing.

1. Slide the extension wing to desired position and tighten the knob.
2. The stop plate (1) is designed for use during repetitive cutting. Only use one stop plate a time. To use this function, simply rotate the stop plate to vertical position.

**Fig. EE**

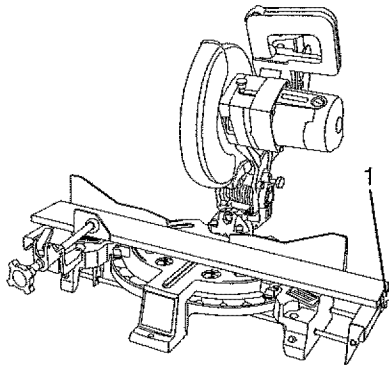

**SETTING UP THE TABLES FOR ANGLE CUTS USING THE ANGLE FINDER (FIG. FF, GG)**

The MiterMate™ accurate angle cutting is suited to do with the fact that most walls and ceiling are not 90 degrees to each other, and so you can make the accurate angles for fewer miscut and quicker task completion.

**Using the MiterMate™ angle finder to copy a corner angle:**

1. Unlock the MiterMate™ angle finder by loosening the knob (1), open up the paddles (2) to copy the corner angle.

**Fig. FF**

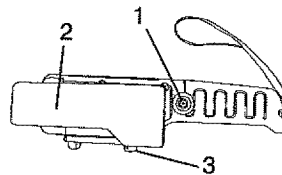

- a) For inside corner, adjust the paddles to make the angle (X1) between two paddles larger than the inside corner angle (X2), and then butt each paddle flat against the wall surface.
- b) For outside corner, adjust the paddles to make the angle (Y1) between two paddles smaller than the outside corner angle (Y2), and then butt each paddle flat against the wall surface.

**Fig. GG**

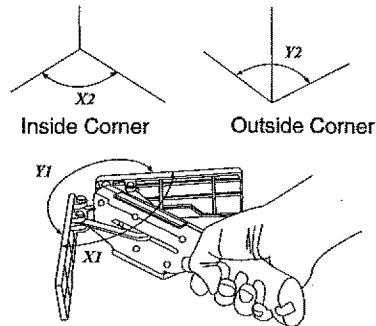



2. Tighten the knob to the lock position and remove the MiterMate™ angle finder from the corner.

**Adjusting the sliding fences for miter angle setting (Fig. HH):**

1. Place the angle copied MiterMate™ angle finder on the saw. Make sure the fitting block (3 - Fig. FF) under the angle finder is inserted into the slot (4) through table.
2. Individually unlock the left and right sliding fence units by unlocking the positive stop lock lever (5) behind the fence unit and lift up the lock lever (6) pivotally connected in the base.
3. Individually slide the left and right sliding fence units toward the paddles until each sliding fence unit (7) flat against the paddle (8).
4. Individually lock the left and right sliding fence units by flipping down the lock lever (6).
5. Remove the MiterMate™ angle finder from the saw.
6. Respectively place a base/crown molding piece against the left and right sliding fence units, and perform the cross cutting to accomplish base/crown molding cutting.

**Fig. HH**

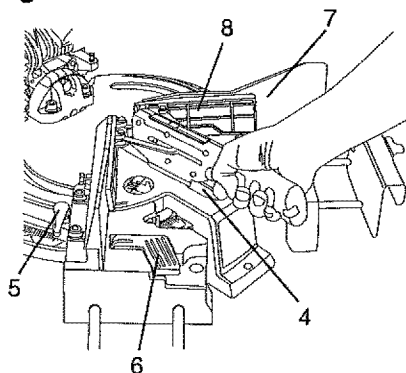

**Cutting crown molding:**

Your miter saw is suited for making the difficult task of cutting crown molding easily. To fit properly, crown molding must be cut with extreme accuracy.

The two surfaces on a piece of crown molding that fit flat against the ceiling and wall are at angles that, when added together equal exactly 90°. Most crown molding has a top rear angle (the section that fits flat against the ceiling) and a bottom rear angle (the section that fits flat against the wall). The two common spring angles for crown molding are: 52°/38° and 45°/45°.

1. Determine the spring angle for the crown molding, for example, 52/38 degrees as shown in Fig. II.

**Fig. II**

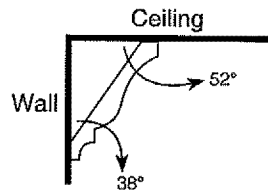

2. Measure the angle of corner by angle finder and lock the sliding fences unit in positions.
3. Place the crown molding piece upside down with against the table and the fence as shown in Fig. JJ. (Think of the table as the ceiling.)

**Fig. JJ**

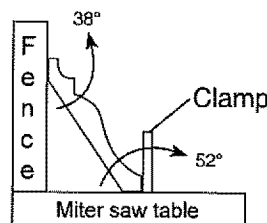

- Use the clamp to secure the molding piece and hold it at the proper spring angle.  
**NOTE:** Use the extension wings to steady long molding pieces.
- Cut on the side of the saw as shown in the following chart.

Ceiling/Wall (Crown Molding Orientation)				
Orientation	Inside corner		Outside corner	
	Right side of wall	Left side of wall	Right side of wall	Left side of wall
Cut on this side of the saw	Left	Right	Left	Right

**NOTE:** If molding piece is too tall, cut flat using the instructions of a conventional way on page 35.

#### Cutting base molding:

Base moldings and many other moldings can be cut on your miter saw. The setup of the saw depends on molding characteristics and application. Perform practice cuts on scrap material to achieve best results.

- Place the base molding piece upside against the fence and table as shown in Fig. KK.

**Fig. KK**

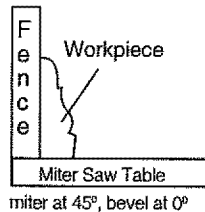

- Measure the angle of corner by angle finder and lock the sliding fences unit in positions.
- Use the clamp to secure the base molding piece.  
**NOTE:** Use the telescoping extension wings to support long molding pieces.
- Cut on the side of the saw as shown in the following chart.

Wall/Ground (Base Molding Orientation)				
Orientation	Inside corner		Outside corner	
	Right side of wall	Left side of wall	Right side of wall	Left side of wall
Cut on this side of the saw	Right	Left	Right	Left

**NOTE:** If molding piece is too tall, reset fences to 0° and cut flat using the bevel like a conventional saw.

## CONVENTIONAL WAY OF CUTTING CROWN/BASE MOLDING

The following instructions are not the optimum way to cut molding using the MiterMate™ cutting feature. Use these instructions only for cutting molding too large for the MiterMate™ feature.

### Cutting base molding (Fig. MM):

Base moldings and many other moldings can be cut on a compound miter saw. The setup of the saw depends on molding characteristics and application, as shown. Perform practice cuts on scrap material to achieve best results:

1. Always make sure moldings rest firmly against fence and table. Use hold-down or C-clamps, whenever possible, and place tape on the area being clamped to avoid marks.
2. Reduce splintering by taping the cut area prior to making cut. Mark cut line directly on the tape.
3. Splintering typically happens due to wrong blade application and thinness of the material.

Fig. MM

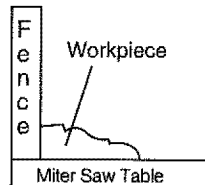

miter at 0°, bevel at 45°

**NOTE:** Always perform a dry run cut so you can determine if the operation being attempted is possible before power is applied to the saw.

### Cutting crown molding (Fig. NN, OO):

Your compound miter saw is suited for the difficult task of cutting crown molding. To fit properly, crown molding must be cut with extreme accuracy. The two surfaces on a piece of crown molding that fit flat against the ceiling and wall are at angles that, when added together equal exactly 90°.

**In order to accurately cut crown molding for a 90° inside or outside corner,** lay the molding with its broad back surface flat on the saw table.

When setting the bevel and miter angles for compound miters, remember that the settings are interdependent; changing one changes the other, as well.

Fig. NN

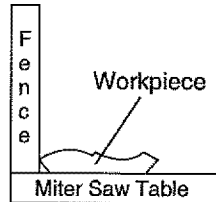

## Bevel/Miter Settings

**Fig. 00**

Settings for standard crown molding lying flat on compound miter saw table

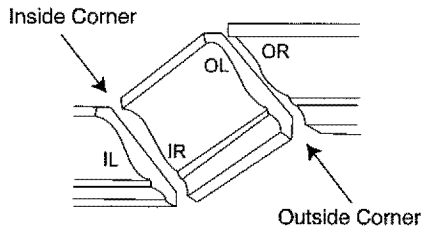

**NOTE: The chart below references a compound cut for crown molding ONLY WHEN THE ANGLE BETWEEN THE WALLS EQUALS EXACTLY 90°.**

KEY	BEVEL SETTING	MITER SETTING	TYPE OF CUT
<b>Inside corner-Left side</b>			
IL	33.9°	31.6° Right	1. Position top of molding against fence. 2. Miter table set at RIGHT 31.6°. 3. LEFT side is finished piece.
<b>Inside corner-Right side</b>			
IR	33.9°	31.6° Left	1. Position bottom of molding against fence. 2. Miter table set at LEFT 31.6°. 3. LEFT side is finished piece.
<b>Outside corner-Left side</b>			
OL	33.9°	31.6° Left	1. Position bottom of molding against fence. 2. Miter table set at LEFT 31.6°. 3. RIGHT side is finished piece.
<b>Outside corner-Right side</b>			
OR	33.9°	31.6° Right	1. Position top of molding against fence. 2. Miter table set at RIGHT 31.6°. 3. RIGHT side is finished piece.

**CROWN MOULDING CHART**  
**MiterMate™ Miter Saw**  
**Miter and Bevel Angle Settings**  
**Wall to Crown Molding Angle**

Angle Between Walls	52/38° Crown Moulding		45/45° Crown Moulding	
	Mitre Setting	Bevel Setting	Mitre Setting	Bevel Setting
67	42.39	41.08	46.69	36.13
68	42.39	40.79	46.35	35.89
69	41.85	40.50	45.81	35.64
70	41.32	40.20	45.28	35.40
71	40.79	39.90	44.75	35.15
72	40.28	39.61	44.22	34.89
73	39.76	39.30	43.70	34.64
74	39.25	39.00	43.18	35.38
75	38.74	38.69	42.66	34.12
76	38.24	38.39	42.15	33.86
77	37.74	38.08	41.64	33.60
78	37.24	37.76	41.13	33.33
79	36.75	37.45	40.62	33.07
80	36.27	37.13	40.12	32.08
81	35.79	36.81	39.62	32.53
82	35.31	36.49	39.13	32.25
83	34.83	36.17	38.63	31.98
84	34.36	35.85	38.14	31.70
85	33.90	35.52	37.66	31.42
86	33.43	35.19	37.17	31.34
87	32.97	34.86	36.69	30.86
88	32.52	34.53	36.21	30.57
89	32.07	34.20	35.74	30.29
90	31.62	33.86	35.26	30.00
91	31.17	33.53	34.79	29.71
92	30.73	33.19	34.33	29.42
93	30.30	32.86	33.86	29.13
94	29.86	32.51	33.40	28.83
95	29.43	32.17	32.94	28.54
96	29.00	31.82	32.48	28.24
97	28.58	31.48	32.02	27.94
98	28.16	31.13	31.58	27.64
99	27.74	30.78	31.13	27.34
100	27.32	30.43	30.68	27.03
101	26.91	30.08	30.24	26.73
102	26.50	29.73	29.80	26.42
103	26.09	29.38	29.36	26.12
104	25.69	29.02	28.92	25.81
105	25.29	28.67	28.48	25.50
106	24.89	28.31	28.05	25.19
107	24.49	27.96	27.62	24.87
108	24.10	27.59	27.19	24.56
109	23.71	27.23	26.77	24.24
110	23.32	26.87	26.34	23.93
111	22.93	26.51	25.92	23.61
112	22.55	26.15	25.50	23.29
113	22.17	25.78	25.08	22.97
114	21.79	25.42	24.66	22.66
115	21.42	25.05	24.25	22.33
116	21.04	24.68	23.84	22.01
117	20.67	24.31	23.43	21.68
118	20.30	23.94	23.02	21.36
119	19.93	23.57	22.61	21.03
120	19.57	23.20	22.21	20.70
121	19.20	22.83	21.80	20.38
122	18.84	22.46	21.40	20.05
123	18.48	22.09	21.00	19.72

Angle Between Walls	52/38° Crown Moulding		45/45° Crown Moulding	
	Mitre Setting	Bevel Setting	Mitre Setting	Bevel Setting
124	18.13	21.71	20.61	19.39
125	17.77	21.34	20.21	19.06
126	17.42	20.96	19.81	18.72
127	17.06	20.59	19.42	18.39
128	16.71	20.21	19.03	18.06
129	16.37	19.83	18.64	17.72
130	16.02	19.45	18.25	17.39
131	15.67	19.07	17.86	17.05
132	15.33	18.69	17.48	16.71
133	14.99	18.31	17.09	16.38
134	14.66	17.93	16.71	16.04
135	14.30	17.55	16.32	15.70
136	13.97	17.17	15.94	15.36
137	13.63	16.79	15.56	15.02
138	13.30	16.40	15.19	14.62
139	12.96	16.02	14.81	14.34
140	12.63	15.64	14.43	14.00
141	12.30	15.25	14.06	13.65
142	11.97	14.87	13.68	13.31
143	11.64	14.48	13.31	12.97
144	11.31	14.09	12.94	12.62
145	10.99	13.71	12.57	12.29
146	10.66	13.32	12.20	11.93
147	10.34	12.93	11.83	11.59
148	10.01	12.54	11.46	11.24
149	9.69	12.16	11.09	10.89
150	9.37	11.77	10.73	10.55
151	9.05	11.38	10.36	10.20
152	8.73	10.99	10.00	9.85
153	8.41	10.60	9.63	9.50
154	8.09	10.21	9.27	9.15
155	7.77	9.82	8.91	8.80
156	7.46	9.43	8.55	8.45
157	7.14	9.04	8.19	8.10
158	6.82	8.65	7.83	7.75
159	6.51	8.26	7.47	7.40
160	6.20	7.86	7.11	7.05
161	5.88	7.47	6.75	6.70
162	5.57	7.08	6.39	6.35
163	5.26	6.69	6.03	6.00
164	4.95	6.30	5.68	5.65
165	4.63	5.90	5.32	5.30
166	4.32	5.51	4.96	4.94
167	4.01	5.12	4.61	4.59
168	3.70	4.72	4.25	4.24
169	3.39	4.33	3.90	3.89
170	3.08	3.94	3.54	3.53
171	2.77	3.54	3.19	3.10
172	2.47	3.15	2.83	2.83
173	2.15	2.75	2.48	2.47
174	1.85	2.36	2.12	2.12
175	1.54	1.97	1.77	1.77
176	1.23	1.58	1.41	1.41
177	0.92	1.18	1.06	1.06
178	0.62	0.79	0.71	0.71
179	0.31	0.39	0.35	0.35

# MAINTENANCE

## MAINTENANCE

### **▲ DANGER**

To avoid injury, never put lubricants on the blade while it is spinning.

### **▲ WARNING**

- To avoid fire or toxic reaction, never use gasoline, naphtha acetone, lacquer thinner or similar highly volatile solvents to clean the miter saw.
- To avoid injury from unexpected starting or electrical shock, unplug the power cord before working on the saw.
- For your safety, this saw is double-insulated. To avoid electrical shock, fire or injury, use only parts identical to those identified in the parts list. Reassemble exactly as the original assembly to avoid electrical shock.

## REPLACING CARBON BRUSHES (FIG. PP)

Replace both carbon brushes when either has less than 1/4 in. length of carbon remaining, or if the spring or wire is damaged or burned. To inspect or replace brushes, first unplug the saw. Then remove the black plastic cap (1) on the side of the motor (2). Remove the cap cautiously, because it is springloaded. Then pull out the brush and replace. Replace for the other side. To reassemble reverse the procedure. The ears on the metal end of the assembly go in the same hole the carbon part fits into. Tighten the cap snugly, but do not overtighten.

**NOTE:** To reinstall the same brushes, first make sure the brushes go back in the way they came out. This will avoid

a break-in period that reduces motor performance and increases wear.

Fig. PP

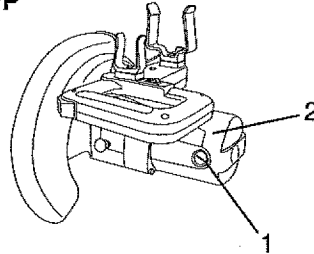

## LOWERING BLADE GUARD

Do not use the saw without the lower blade guard. The lower blade guard is attached to the saw for your protection. Should the lower guard become damaged, do not use the saw until the damaged guard has been replaced. Develop a regular check to make sure the lower guard is working properly. Also check before each use that all bolt/screws are tight. Clean the lower guard of any dust or buildup with a damp cloth.

### **▲ WARNING**

- When cleaning the lower guard, unplug the saw from the power source receptacle to avoid unexpected startup.
- Do not use solvents on the guard. They could make the plastic "cloudy" and brittle.

## EMPTYING SAWDUST BAG

Periodically, sawdust will accumulate under the work table and base. This could cause difficulty in the movement of the worktable when setting up a miter cut. Frequently blow out or vacuum up the sawdust.

### **▲ WARNING**

Wear proper eye protection to keep debris from entering eyes when removing sawdust from unit.

### LUBRICATION (FIG. QQ)

All the motor bearings in this tool are lubricated with a sufficient amount of high grade lubricant for the life of the unit under normal operating conditions; therefore, no further lubrication is required.

Lubricate the following as necessary:

**Chop pivot:** Apply light machine oil to points indicated in illustration.

**Central pivot of plastic guard:** Use light household oil (sewing machine oil ) on metal-to-metal or metal-to-plastic guard contact areas as required for smooth, quiet operation. Avoid excessive oil, to which sawdust will cling.

### CHECKING AND TIGHTENING THE TABLE LOCK LEVER

After a period of use, the lock levers might loosen and couldn't clamp the sliding fence units tightly. An adjustment is needed. Please see ADJUSTING LOCK LEVERS section on page 24.

Fig. QQ

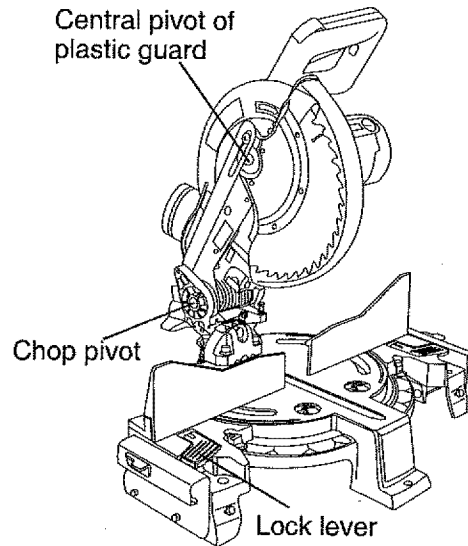

# TROUBLESHOOTING GUIDE

## ▲ WARNING

To avoid injury from accidental starting, always turn switch OFF and unplug the tool before moving, replacing the blade or making adjustments.

### TROUBLESHOOTING GUIDE - MOTOR

PROBLEM	PROBLEM CAUSE	SUGGESTED CORRECTIVE ACTION
Brake does not stop blade within 6 seconds.	<ol style="list-style-type: none"> <li>1. Motor brushes not sealed or lightly sticking.</li> <li>2. Motor brake overheated from use of defective or wrong size blade or rapid ON/OFF cycling.</li> <li>3. Arbor bolt loose.</li> <li>4. Brushes cracked, damaged, etc.</li> <li>5. Other.</li> </ol>	<ol style="list-style-type: none"> <li>1. Inspect/clean/replace brushes. See MAINTENANCE section.</li> <li>2. Use a recommended blade. Let cool down. See REMOVING OR INSTALLING THE BLADE section.</li> <li>3. Retighten. See REMOVING OR INSTALLING THE BLADE section.</li> <li>4. Replace brushes.</li> <li>5. Contact Sears Service Center.</li> </ol>
Motor does not start	<ol style="list-style-type: none"> <li>1. Limit switch failure</li> <li>2. Brush worn.</li> <li>3. Fuse blown or circuit breaker tripped on home panel.</li> </ol>	<ol style="list-style-type: none"> <li>1. Replace limit switch.</li> <li>2. Replace brushes. See MAINTENANCE section.</li> <li>3. Verify there is electrical power at the outlet.</li> </ol>
Brush spark when switch released.	<ol style="list-style-type: none"> <li>1. Brush worn.</li> <li>2. Other.</li> </ol>	<ol style="list-style-type: none"> <li>1. Replace brushes. See MAINTENANCE section.</li> <li>2. Contact Sears Service Center.</li> </ol>

### TROUBLESHOOTING GUIDE - SAW OPERATION

PROBLEM	PROBLEM CAUSE	SUGGESTED CORRECTIVE ACTION
Blade hits table.	<ol style="list-style-type: none"> <li>1. Misalignment.</li> </ol>	<ol style="list-style-type: none"> <li>1. See ADJUSTMENT- CUTTING ARM TRAVEL section.</li> </ol>
Angle of cut not accurate. Can not adjust miter.	<ol style="list-style-type: none"> <li>1. Miter table unlocked.</li> <li>2. Sawdust under table.</li> </ol>	<ol style="list-style-type: none"> <li>1. See OPERATION - Miter Angle Adjustment section.</li> <li>2. Vacuum or blow out dust. WEAR EYE PROTECTION.</li> </ol>
Cutting arm wobbles.	<ol style="list-style-type: none"> <li>1. Loose pivot points.</li> </ol>	<ol style="list-style-type: none"> <li>1. Contact Sears Service Center.</li> </ol>
Cutting arm will not fully raise, or blade guard won't fully close.	<ol style="list-style-type: none"> <li>1. Pivot spring not replaced properly after service.</li> <li>2. Sawdust build-up.</li> </ol>	<ol style="list-style-type: none"> <li>1. Clean and lubricate moving parts.</li> <li>2. Contact Sears Service Center.</li> </ol>
Blade binds, jams, burns wood.	<ol style="list-style-type: none"> <li>1. Improper operation.</li> <li>2. Dull or warped blade.</li> <li>3. Improper blade size.</li> <li>4. Wood is moving during cut.</li> </ol>	<ol style="list-style-type: none"> <li>1. See BASIC SAW OPERATION section.</li> <li>2. Replace or sharpen blade.</li> <li>3. Replace with 10 in. diameter blade.</li> <li>4. Use clamp to secure workpiece to fence unit and table.</li> </ol>
Saw vibrates or shakes.	<ol style="list-style-type: none"> <li>1. Saw blade not round / damaged / loose.</li> <li>2. Arbor bolt loose.</li> </ol>	<ol style="list-style-type: none"> <li>1. Replace blade.</li> <li>2. Tighten arbor bolt.</li> </ol>



# PARTS LIST

10" MiterMate™ MITER SAW

MODEL NO. 137.212260



**When servicing use only CRAFTSMAN replacement parts. Use of any other parts may create a HAZARD or cause product damage. Any attempt to repair or replace electrical parts on this Miter Saw may create a HAZARD unless repair is done by a qualified service technician. Repair service is available at your nearest Sears Service Center.**

## PARTS LIST FOR SAW SCHEMATIC A

ID	Description	Size	QTY	ID	Description	Size	QTY
0831	SHAFT SLEEVE		1	2CA8	CR. RE. TRUSS HD. ROUND NECK SCREW	M6*1.0-12	1
083S	TRIGGER		1	2E7D	CR.RE. PAN HD. ROUND NECK SCREW	M6*1.0-9	1
083Y	COMPRESSION SPRING		1	2K96	WARNING LABEL		1
083Z	CORD CLAMP		1	2MAR	STICKER		1
0CES	COMPRESSION SPRING		1	2NQ6	RIVET		2
0D87	TORSION SPRING	ø50 N=8	1	2T9B	ROCKER SWITCH ASS'Y		1
0D9B	ANCHOR BLOCK		1	2V8U	PC-GUARD ASS'Y		1
0DHT	SPRING GUARD		1	2VFG	MOTOR ASS'Y		1
0DVJ	BLADE WRENCH		1	2VFP	ARM	#CQ	1
0J4C	FLAT WASHER	ø4*8-1	1	2Vfq	LASER SET		1
0J4E	FLAT WASHER	ø6*13-1	1	2VFR	CABLE SHIELD		1
0JB0	WAVE WASHER		1	2VG3	PLUNGER HANDLE		1
0JYV	HEX. SOC. HD. CAP BOLT	M6*1.0-16	1	2VGB	BRACKET	#CQ	1
0JZD	HEX. SOC. SET SCREW	M5*0.8-10	2	2VGC	CHUCK KEY SEAT		1
0JZN	ARBOR BOLT	M8*1.25-20	1	2VGD	CHUCK KEY SEAT		1
0K5C	CR. RE. COUNT HD. SCREW	M6*1.0-16	1	2VGE	MOTOR HANDLE		1
0K74	CR.-RE. TRUSS HD. SCREW	M6*1.0-8	1	2VGF	MOTOR HANDLE		1
0K7Z	CR. RE. TRUSS HD. ROUND NECK SCREW	M6*1.0-14	1	2VGS	AXLE SEAT		2
0KA0	CR.RE. PAN HD. TAPPING SCREW	M5*12-20	2	2VGU	LASER PLUNGER HOUSING		1
0KA4	CR.RE. PAN HD. TAPPING SCREW	M4*16-16	2	2VGV	SET COVER		1
0KB7	CR.RE. PAN HD. TAPPING SCREW	M4*18-16	10	2VGW	PIN		1
0KB8	CR.RE. PAN HD. TAPPING SCREW	M4*18-20	4	2VKG	BRACKET	#CQ	1
0KD7	CR. RE. PAN HD. SCREW	M4*0.7-10	3	2VRT	CUTTER SHAFT GUARD	#CQ	1
0KDH	CR. RE. PAN HD. SCREW	M5*0.8-8	3	2VSO	LEAD WIRE ASS'Y		1
0KE0	CR. RE. PAN HD. SCREW	M6*1.0-40	2	2VSN	BUMPER		1
0KQG	CROWN NUT	M4*0.7T=6.5	1	2VT2	ANGLE FINDER		1
0KQX	NUT	M6*1.0 T=6	1	2WFZ	BUTTON SWITCH		1
0KR3	LOCK NUT	M6*1.0 T=8	1	2WG8	LEVER		1
0KUW	TERMINAL		2	2WGD	COLLAR		1
0LU2	LIMIT SWITCH		1	2WP7	CONTROLLER ASS'Y		1
0XQ8	CR.RE. PAN HD. TAPPING SCREW	M6*1.0-20	2	2WPX	POWER CABLE		1
0ZYX	CR. RE. TRUSS HD. TAPPING SCREW	M3*24-8	1	2WQ2	OPERATOR'S MANUAL		1
21GM	FLAT WASHER	ø4*10-1	3	2WQU	BAG-DUST ASS'Y		1
23NF	ARBOR COLLAR		2	2WRT	TRADE-MARK LABEL		1
23NX	GUARD-CORD		1	2WRU	TRADE-MARK LABEL		1
250Z	HEX.SOCKET HD.CAP SCREWS	M5*0.8-35	3	2WRY	LABEL		1
26LU	WARNING LABEL		1	2WS0	CAUTION STICKER		1
290M	CAUTION LABEL		1	2X5H	LASER ASS'Y		1
2C88	BLADE		1	2X6M	LABEL		1



10" MiterMate™ MITER SAW

MODEL NO. 137.212260

PARTS LIST FOR SAW SCHEMATIC B

ID	Description	Size	QTY	ID	Description	Size	QTY
0824	PIVOT SHAFT		1	2VED	RIGHT-ASSIST-FENCE	#CQ	1
0826	NEEDLE POINTER	#23	1	2VEE	LEFT-ASSIST-FENCE	#CQ	1
0828	ROTATION SLIDE PLATE		1	2VEF	RIGHT-CLAMP-HANDLE	#CQ	1
081U	SUPPORT	#CQ	1	2VEH	LEFT-CLAMP-HANDLE	#CQ	1
0D7W	CLEVIS PIN		1	2VEL	BOLT		2
0D7Z	KNOB-HANDLE		1	2VEN	PLUNGER-HOUSING		2
0G81	SADDLE	Ø5	2	2VEP	SHAFT		1
0J4E	FLAT WASHER	Ø6*13-1	4	2VEQ	LEFT-NEEDLE-POINTER		1
0J4J	FLAT WASHER	Ø10*20-2	1	2VES	LEFT-ARM-MITER	#CQ	1
0J7G	FLAT WASHER	3/8*29/32-1/8	1	2VET	RIGHT-ARM-MITER	#CQ	1
0JBH	DISC SPRING WASHER	Ø10	1	2VEW	COLLAR		2
0JMM	O-RING		1	2VEY	RIGHT-NEEDLE-POINTER		1
0JPE	HEX. HD. BOLT	M6*1.0-2	3	2VFS	COVER		1
0JPU	HEX. HD. BOLT	M8*1.25-20	2	2VFT	ROLL PIN		2
0JX3	HEX. SOC. SET SCREW	M5*0.8-8	2	2VGG	SPECIAL BOLT		2
0JXA	HEX. SOC. SET SCREW	M6*1.0-12	2	2VGH	PLUNGER HANDLE		1
0JZD	HEX. SOC. SET SCREW	M5*0.8-10	1	2V GK	BOLT CLAMP		2
0JZF	HEX. SOC. SET SCREW	M6*1.0-10	4	2VGR	LEVELING PAD		2
0K24	HEX SOC. HD. CAP SCREW	M8*1.25-35	2	2V.14	DETENT LOCK KNOB		1
0K2D	HEX.SOCKET HD.CAP SCREWS	M8*1.25-25	8	2VMA	CUSHION		2
0K2E	HEX.SOCKET HD.CAP SCREWS	M8*1.25-40	2	2VPG	ANGLE PEGULATOR	#CQ	1
0K56	CR. RE. COUNT HD. SCREW	M5*0.8-12	2	2VT1	COMPRESSION SPRING		2
0KDH	CR. RE. PAN HD. SCREW	M5*0.8-8	2	2VT4	WISE ASS'Y		1
0KDJ	CR. RE. PAN HD. SCREW	M5*0.8-12	2	2VT6	EXTENSION TABLE ASS'Y (RIGHT)		1
0KDR	CR. RE. PAN HD. SCREW	M5*0.8-10	1	2VT7	EXTENSION TABLE ASS'Y (LEFT)		1
0KMR	HEX. NUT	M5*0.8 T=4	2	2VV7	SCREW BAR ASS'Y		1
0KMS	HEX. NUT	M6*1.0 T=5	5	2WEJ	BUSH		2
0KMY	HEX. NUT	M8*1.25T=6.5	2	2WHR	ROLLING WHEEL		2
0KQW	LOCK NUT	M5*0.8 T=5	2	2WJC	HOLDER LINK		1
0KQZ	NUT	M10*1.5 T=10	1	2WJD	HOLDER LINK		1
20VD	CR. RE. TRUSS HD. ROUND NECK SCREW	M6*1.0-16	2	2WK5	LINK PLATE		2
2B5S	HEX. HD. BOLT	M10*1.5-75	1	2WRV	WARNING LABEL		1
2C8U	KNOB	M5*0.8-25	2	2WRW	TILTING SCALE		1
2N72	RUBBER INSERT		8	2WRZ	BRACKET-TILT		2
2SER	HOLD DOWN CLAMP ASS'Y		1	2WS1	CAUTION LABEL		1
2VE6	BASE	#GE	1	2WS2	CAUTION LABEL		2
2VE8	RIGHT-PIVOT-SUPPORT	#GE	1	2X16	FLAT WASHER	Ø8*18-2	6
2VE9	LEFT-PIVOT-SUPPORT	#GE	1	2X5U	FLAT WASHER	Ø5*10-2	2
2VEB	RIGHT-FENCE	#CQ	1	2X5W	RETAINING RING		2
2VEC	LEFT-FENCE	#CQ	1				

