

# ***Safety Instructions & Operator's Manual for***

# ***SNAPPER***®

## ***TRANSAXLE DRIVE WALK-BEHIND MOWER***

<b>MOWER UNIT MODEL</b> SFH13320KW
---------------------------------------

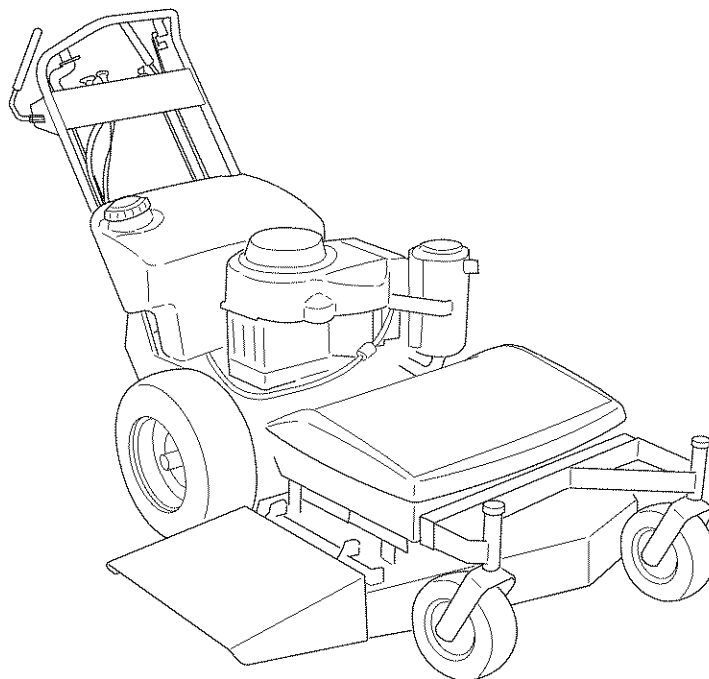

***Thank you for buying a SNAPPER Product! Before operating your WALK BEHIND, read this manual carefully and pay particular attention to the "IMPORTANT SAFETY INSTRUCTIONS" on pages 1 - 3. Remember that all power equipment can be dangerous if used improperly. Also keep in mind that SAFETY requires careful use in accordance with the operating instructions and common sense!***

***SNAPPER***® McDonough, GA 30253 USA



# IMPORTANT SAFETY INSTRUCTIONS



**WARNING:** This powerful cutting machine is capable of amputating hands and feet and can throw objects that can cause injury and damage! Failure to comply with the following **SAFETY** instructions could result in serious injury or death to the operator or other persons. The owner of the machine must understand these instructions and must allow only persons who understand these instructions to operate machine. Each person operating the machine must be of sound mind and body and must not be under the influence of any substance, which might impair vision, dexterity or judgment. If you have any questions pertaining to your machine which your dealer cannot answer to your satisfaction, call or write the Customer Service Department at SNAPPER, McDonough, Georgia 30253. Phone: (1-800-935-2967).

## PROTECTION FOR CHILDREN

Tragic accidents can occur if the operator is not alert to the presence of children. Children are often attracted to the machine and the mowing activity. Never assume that children will remain where you last saw them.

1. **KEEP** children out of the mowing area and under the watchful care of a responsible adult.
2. **DO NOT** allow children in yard when machine is operated (even with the blades **OFF**).
3. **DO NOT** allow children or others to ride on machine, attachments, or towed equipment (even with the blades **OFF**). They may fall and be seriously injured.
4. **DO NOT** allow pre-teenage children to operate or service the machine. Local regulations may restrict the age of the operator.
5. **ALLOW** only adults or responsible teenagers with mature judgment under close adult supervision to operate machine.
6. **DO NOT** operate blades in reverse. **STOP BLADES. LOOK** and **SEE** behind and down for children, pets and hazards before and while backing.
7. **USE EXTRA CARE** when approaching blind corners, shrubs, trees, or other objects that may obscure vision.

## SLOPE OPERATION

1. Slopes are a major factor related to slip and fall accidents, which can result in severe injury. All slopes require extra caution and slow speed. If you feel uneasy on a slope, **DO NOT** mow it.
2. Exercise extreme **CAUTION** when changing directions on slopes. Practice operation of machine on slopes with blades off.
3. Use extra care with grass catchers or other attachments: these affect the handling and the stability of the machine.
4. **DO NOT** use tow behind attachments on slopes.
5. **AVOID** uphill starts.
6. Turf conditions can affect the machine's stability. **DO NOT** operate machine under any condition where traction, steering or stability is doubtful.
7. Choose a low enough ground speed setting so that you will not have to stop or shift on a slope. Tires may lose traction on slopes even though the brakes are functioning properly.

## SLOPE OPERATION

(Continued From Previous Column)

8. Always keep the machine in gear when going down slopes. **DO NOT** shift to neutral (or actuate the hydro roll release) and coast down hill.

## PREPARATION

1. Read, understand and follow instructions and warnings in this manual and on the machine, engine, and attachments. Know the controls and the proper use of the machine before starting. If the operators or mechanics cannot read English, it is the owner's responsibility to explain this material to them.
2. Only mature, responsible persons shall operate the machine and only after proper instruction. The owner is responsible for training the operators. Further, the owner/operator can prevent and/or is responsible for accidents or injuries occurring to themselves, other people or property.
3. Data indicates that operators age 60 and above, are involved in a large percentage of mower-related injuries. These operators should evaluate their ability to operate the mower safely enough to protect themselves and others from serious injury.
4. Handle fuel with extra care. Fuels are flammable and vapors are explosive. Use only an approved fuel container. **DO NOT** remove fuel cap or add fuel with engine running. Add fuel outdoors only with engine stopped and cool. Clean spilled fuel from machine. **DO NOT** smoke.
5. Practice operation of machine with **BLADES OFF** to learn controls and develop skills.
6. Check the area to be mowed and remove all objects such as toys, wire, rocks, limbs and other objects that could cause injury if thrown by blade or interfere with mowing.
7. Evaluate the terrain to determine what accessories and attachments are needed to properly and safely perform the job. Only use accessories and attachments approved by SNAPPER.
8. Keep people and pets out of mowing area. Immediately, **STOP** blades, **STOP** engine, and **Stop** machine if anyone enters the area.
9. **DO NOT** operate machine unless all shields, deflectors, switches, blade controls and other safety devices are in place and functioning properly.
10. Make sure all safety decals are clearly legible. Replace if damaged.



# IMPORTANT SAFETY INSTRUCTIONS



## PREPARATION

(Continued From Previous Page)

11. Protect yourself when mowing and wear appropriate clothing including safety glasses, long pants, ear protection, hardhat and substantial footwear with good traction. Long hair, loose clothing or jewelry may get tangled in moving parts.
12. Know how to STOP blades and engine quickly in preparation for emergencies.
13. Use extra care when loading or unloading the machine into a trailer or truck.
14. Check grass catcher components frequently for signs of wear or deterioration and replace as needed to prevent injury from thrown objects going through weak or worn spots.

## SAFE HANDLING OF GASOLINE

To avoid personal injury or property damage, use extreme care in handling gasoline. Gasoline is extremely flammable and the vapors are explosive

1. Extinguish all cigarettes, cigars, pipes and other sources of ignition.
2. Use only an approved fuel container.
3. DO NOT remove fuel cap or add fuel with the engine running. Allow the engine to cool before refueling.
4. DO NOT refuel the machine indoors.
5. DO NOT store the machine or fuel container inside where there is an open flame, spark or pilot light such as on a water heater or other appliances.
6. DO NOT fill fuel containers inside a vehicle or on a truck or trailer bed with a plastic liner. Always place the containers on the ground away from the vehicle before filling.
7. Remove gas-powered equipment from the vehicle or trailer and refuel it on the ground. If this is not possible, then refuel equipment using a portable container, rather than a gasoline dispenser nozzle.
8. DO NOT start gas powered equipment in enclosed vehicles or trailers.
9. Keep the nozzle in contact with the rim of the fuel tank or container opening at all times until fueling is complete. DO NOT use a nozzle lock-open device
10. If fuel is spilled on clothing, change clothing immediately.
11. DO NOT overfill a fuel tank. Replace fuel cap and tighten securely.

## OPERATION

1. DO NOT put hands or feet near or under rotating parts. Keep clear of the discharge area while the engine is running.
2. BEFORE STARTING ENGINE, blades must be OFF and Traction Levers LOCKED in the Traction Lock position.

## OPERATION

(Continued From Previous Column)

3. Stop Blades when crossing gravel drive, walks, and under any conditions where thrown objects might be a hazard.
4. DO NOT raise deck with the blades running.
5. Mow only in daylight or good artificial light.
6. USE EXTRA CARE when approaching blind corners, shrubs, trees or other objects that may obscure vision.
7. DO NOT operate the machine while under the influence of alcohol or drugs.
8. After striking a foreign object or if the mower vibrates abnormally, STOP the blades and engine. Remove the key. Disconnect and secure the spark plug wire. Inspect the mower for any damage and repair the damage.
9. DO NOT operate machine near drop offs, ditches, embankments, washouts culverts, fences and protruding objects. STAY ALERT for holes and other hidden hazards. Tall grass can hide obstacles.
10. DO NOT operate machine on wet grass. Always be sure of your footing while operating machine, especially while backing up. Keep a firm grip on the handle. Walk: never run. Slipping and falling could cause injury.
11. DO NOT leave the machine with the engine running. STOP BLADES, STOP ENGINE and REMOVE KEY before leaving the operator position for any reason.
10. Before cleaning, repairing, or inspecting make certain blades, engine and all moving parts have STOPPED. Remove key and secure spark plug wire away from spark plug key to prevent accidental starting.
11. STOP MACHINE on level ground, engage parking brake (if equipped) and make sure engine and blades have stopped before leaving the operator's position for any reason including removing grass catcher or unclogging mower to prevent injury to hands or feet.
12. Blades must be OFF except when cutting grass. Set blades in highest position when mowing over rough ground.
13. Keep hands and feet away from rotating blades underneath deck.
14. DO NOT operate machine without entire grass catcher or guards in place. DO NOT point discharge at people, passing cars, windows or doors.
15. Slow down before turning.
16. Watch out for traffic when near or crossing roadways.
17. Move motion control levers SLOWLY to maintain control during speed and directional changes.
18. DO NOT operate engine in enclosed areas. Engine exhaust gases contain carbon monoxide, a deadly poison.



# IMPORTANT SAFETY INSTRUCTIONS



## MAINTENANCE

1. Shut off fuel while storing or transporting. **DO NOT** store machine or fuel container inside where fumes may reach an open flame, spark or pilot light such as in a water heater, furnace, clothes dryer or other gas appliance. Allow engine to cool before storing machine in an enclosure. Store fuel container out of the reach of children in a well ventilated, unoccupied building.
2. Clean grass and debris from engine, mufflers, drives and cutting units to help prevent fires. Clean up fuel, oil and excess grease.
3. When draining fuel tank, drain fuel into an approved container outdoors and away from open flame.
4. Check brakes frequently (if equipped); adjust, repair or replace as needed.
5. Keep all bolts, nuts and screws properly tight. Check that all cotter pins are in proper position.
6. Always provide adequate ventilation when running engine. Exhaust gases contain carbon monoxide, an odorless and deadly poison
7. Disconnect battery before performing maintenance or service. Cranking engine could cause injury. Disconnect negative (black) cable from battery first and positive (red) last. Reconnect positive first and negative last. Charge battery in an open well ventilated area, free from spark and flames. Unplug charger before connecting or disconnecting from battery. Wear protective clothing and insulated gloves.
8. Park machine on level ground. **DO NOT** work under machine without safety blocks.
9. Service engine and clean, adjust or repair only when engine and blades are stopped. Remove key. Remove spark plug wire(s) from spark plug(s) and secure wire(s) away from spark plug(s).
10. **DO NOT** change engine governor speed settings or overspeed engine. **DO NOT** make adjustments with the engine running.
11. Lubricate machine at intervals specified in manual to prevent controls from binding.
12. Mower blades are sharp and can cut. Wrap the blades or wear heavy leather gloves and use **CAUTION** when handling them. **DO NOT** straighten or weld blades, only replace them.
13. **DO NOT** test for spark by grounding spark plug next to spark plug hole; spark plug could ignite gas exiting engine.
14. Carefully release pressure from components with stored energy.
15. Have machine serviced by an authorized **SNAPPER** dealer at least once a year and have the dealer install any new safety devices. **DO NOT** allow untrained personnel to service the machine.
16. Use only genuine **SNAPPER** replacement parts to assure that original standards are maintained.

# Table of Contents

<b>Important Safety Instructions</b> .....	1-3	<b>Troubleshooting, Adjustments &amp; Service</b> .....	16
<b>Table of Contents</b> .....	5	Troubleshooting the Mower .....	16
<b>Features &amp; Controls</b> .....	6	Troubleshooting the Mower Deck.....	17
Control Functions.....	6	Cutting Height Adjustment .....	18
Safety Interlock System .....	7	Deck Leveling Adjustment.....	19
<b>Safety Decals</b> .....	8	Belt Removal and Replacement .....	20
<b>Operating the Walk Behind Mower</b> .....	9	Ground Speed Control Lever Adjustment.....	21
General .....	9	PTO Clutch Adjustment .....	22
Checks Before Starting.....	9		
Starting the Engine .....	9		
Driving the Mower .....	9		
Operating On A Slope.....	10		
Stopping the Mower .....	10		
Mowing.....	10		
Pushing the Mower by Hand.....	10		
Storage.....	11		
Starting After Long Term Storage .....	11		
<b>Regular Maintenance</b> .....	12		
Maintenance Schedule .....	12		
Checking Tire Pressure.....	12		
Checking/Adding Fuel.....	13		
Fuel Filter .....	13		
Oil & Filter Change .....	13		
Check / Change Air Filter.....	13		
Lubrication .....	14		
Servicing the Mower Blades .....	15		

## Lawn Care & Mowing Information.....LC—1

*NOTE: In this manual, “left” and “right” are referred to as seen from the operating position.*

### **WARNING**

You must read, understand and comply with all safety and operating instructions in this manual before attempting to set-up and operate your machine.

Failure to comply with all safety and operating instructions can result in loss of machine control, serious personal injury to you and / or bystanders, and risk of equipment and property damage. The triangle in the text signifies important cautions or warnings which must be followed.

### **WARNING**

**Engine exhaust from this product contains chemicals known, in certain quantities, to cause cancer, birth defects, or other reproductive harm.**

# Features & Controls

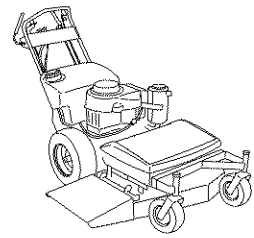

Please take a moment and familiarize yourself with the name, location, and function of these controls so that you will better understand the safety and operating instructions provided in this manual.

**Figure 1. Control Locations**

- A. Motion Control Levers
- B. Engine Ignition Switch
- C. Throttle Control
- D. Choke Control
- E. PTO Engagement Switch
- F. Operator Presence / Parking Brake Handles
- G. Cutting Height Adjust Handle
- H. Fuel Tank Cap

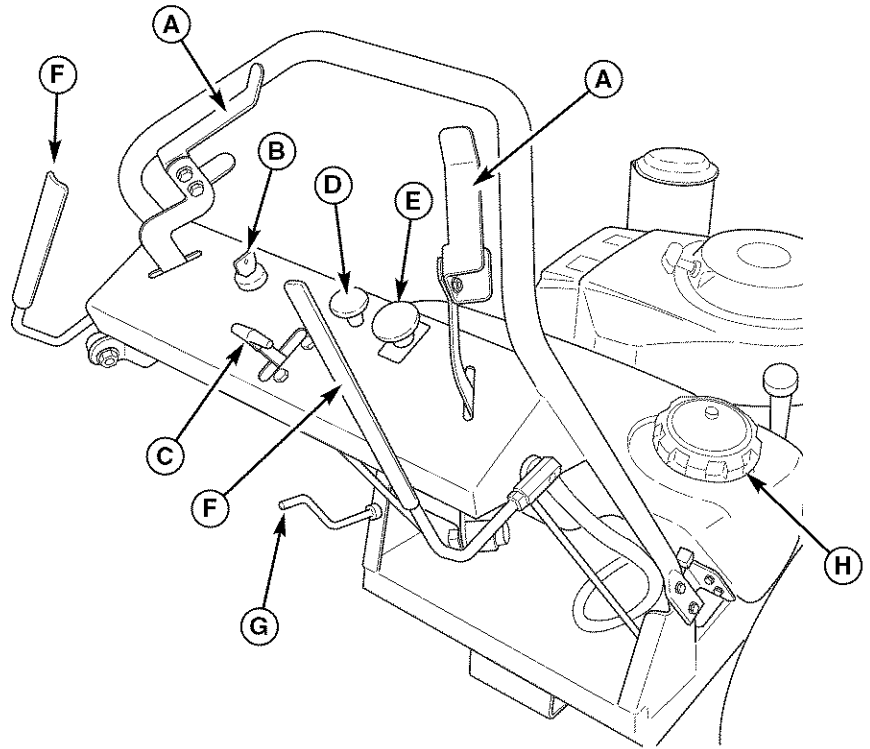

## CONTROL FUNCTIONS

The information below briefly describes the function of individual controls. Starting, stopping, driving, and mowing require the combined use of several controls applied in specific sequences. To learn what combination and sequence of controls to use for various tasks see the OPERATION section.

### A. Motion Control Levers

These levers control the ground speed and direction of motion of the mower. The left and right levers are tied together so you can operate either lever to control the mower's ground speed and forward or reverse direction.

Moving a lever forward increases the FORWARD speed of the mower, and pulling back on a lever increases the REVERSE speed.

*Note: The further a lever is moved away from the neutral position the faster the mower will travel.*

### B. Engine Ignition Switch

Rotate the key switch to the ON position before pulling on the starter rope.

### C. Throttle Control

The throttle controls engine speed. Move the throttle forward to increase engine speed and back to decrease engine speed. Always operate at FULL throttle.

### D. Choke

Close the choke for cold starting. Open the choke once the engine starts. A warm engine may not require choking. Pull the knob up to close the choke.

## E. PTO Engagement Switch

The PTO Engagement Switch engages and disengages the mower blades.

To engage the mower blades, pull up on the switch. To disengage the mower blades, push down on the switch.

When the PTO engagement lever or switch is in the Engaged position, the Engine Kill system is activated.

## F. Operator Presence / Parking Brake Handles

This control deactivates the engine kill system and disengages the parking brake when depressed. Release the handles to activate the engine kill system and engage the parking brake. The engine will shut off if the operator releases the handles with the PTO engaged.

## G. Cutting Height Adjust Handle

The cutting height adjust handle controls the mower cutting height. To adjust the mower cutting height, turn the crank handle clockwise to raise the cutting height. Turn the crank handle counterclockwise to lower the cutting height. Observe the cutting height indicator on the left side of the mower deck.

## H. Fuel Tank Cap

To remove cap, turn counterclockwise.



## SAFETY INTERLOCK SYSTEM

This unit is equipped with safety interlock switches and other safety devices. These safety systems are present for your safety, do not attempt to bypass safety switches, and never tamper with safety devices. Check their operation regularly.

### Operational SAFETY Checks

Your unit is equipped with an operator presence switch safety system. Check the operator presence switch operation every fall and spring with the following tests.

#### Test 1 — Engine WILL NOT start if:

- PTO switch is engaged.

#### Test 2 — Engine WILL start if:

- PTO switch is NOT engaged.

#### Test 3 — Engine should SHUT OFF if:

- Operator releases the operator presence / parking brake handles with PTO engaged.

#### Test 4 — Blade Brake Check

Mower blades and mower drive belt should come to a complete stop within five seconds after electric PTO switch is turned off (or operator releases operator presence handles). If mower drive belt does not stop within five seconds, see your dealer.

*NOTE: Once the engine has stopped, PTO switch must be turned off in order to start the engine.*

## WARNING

**If the unit does not pass a safety test, do not operate it. See your authorized dealer. Under no circumstance should you attempt to defeat the purpose of the safety interlock system.**

# Features & Controls

## SAFETY DECALS

This unit has been designed and manufactured to provide you with the safety and reliability you would expect from an industry leader in outdoor power equipment manufacturing.

Although reading this manual and the safety instructions it contains will provide you with the necessary basic knowledge to operate this equipment safely and effectively, we have placed several safety labels on the unit to remind you of this important information while you are operating your unit.

All DANGER, WARNING, CAUTION and instructional messages on your rider and mower should be carefully read and obeyed. Personal bodily injury can result when these instructions are not followed. The information is for your safety and it is important!

If any of these decals are lost or damaged, replace them at once. See your local dealer for replacements.

These labels are easily applied and will act as a constant visual reminder to you, and others who may use the equipment, to follow the safety instructions necessary for safe, effective operation.

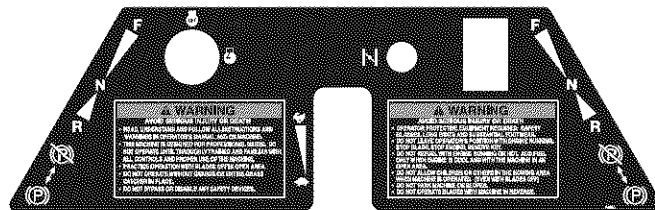

Decal - Dash Panel  
Part No. 5049066



Decal - Hot  
Part No. 1704473

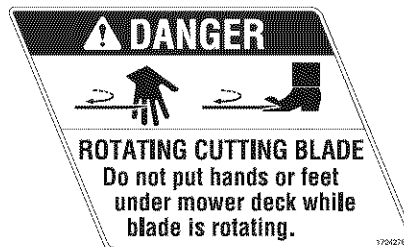

Decal - Danger  
Part No. 1704276



Decal - Danger  
Part No. 1704277



Decal - Danger  
Part No. 7013010



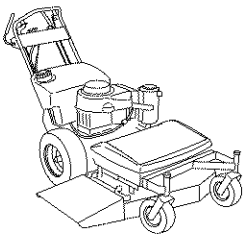

# Operating the Walk Behind Mower

## GENERAL OPERATING SAFETY

Before first time operation:

- Be sure to read all information in the Safety and Operation sections before attempting to operate this machine.
- Become familiar with all of the controls and how to stop the unit.
- Drive in an open area without mowing to become accustomed to the unit.

## CHECKS BEFORE STARTING

- Check that crankcase is filled to full mark on dipstick. See the engine Operator's Manual for instructions and oil recommendations.
- Make sure all nuts, bolts, screws and pins are in place and tight.
- Fill the fuel tank with fresh fuel. Refer to engine manual for fuel recommendations.
- Make sure fuel shut off valve is in the ON position.

### **WARNING**

Before leaving the operator's position for any reason, disengage the PTO, stop the engine and remove the key.

To reduce fire hazard, keep the engine and mower free of grass, leaves and excess grease. Do not stop or park machine over dry leaves, grass or combustible materials.

Gasoline is highly flammable and must be handled with care. Never fill the tank when the engine is still hot from recent operation. Do not allow open flame, smoking or matches in the area. Avoid over-filling and wipe up any spills.

### **WARNING**

If you do not understand how a specific control functions, or have not yet thoroughly read the FEATURES & CONTROLS section, do so now.

Do NOT attempt to operate the machine without first becoming familiar with the location and function of ALL controls.

## STARTING THE ENGINE

- Make sure the PTO switch is disengaged.
- Set the engine throttle control to FAST throttle position. Then fully close the choke by pulling the knob OUT fully.

*NOTE: A warm engine may not require choking.*

- Insert the key into the ignition switch and turn it to RUN.
- Grasp recoil handle and pull cord briskly. (You may have to pull several times before engine starts. If engine fails to start within a reasonable number of attempts, discontinue and check engine manual for further instructions.)

*NOTE: Be sure recoil cord retracts fully into recoil unit. A slack recoil cord can cause serious personal injury and/or damage to unit.*

- After the engine starts, gradually open the choke (push knob down fully).

*Warm up the engine by running it for at least a minute before engaging the PTO lever/switch or driving the mower.*

**After warming the engine, ALWAYS operate the unit at FULL THROTTLE when mowing.**

**In the event of an emergency the engine can be stopped by simply turning the ignition switch to STOP. Use this method only in emergency situations. For normal engine shut down follow the procedure given in STOPPING THE MOWER.**

## DRIVING THE MOWER

- Make sure the PTO switch is disengaged.
- Start the engine (see STARTING THE ENGINE).
- Set the throttle control to FULL.
- Grasp the operator presence / parking brake handles and the handle bar grips at the same time to deactivate engine kill system and disengage the parking brake.
- With your thumbs, pressing the ground speed control levers forward will move the mower forward. Pulling them back will move the mower backwards. The farther the levers are pushed or pulled will result in a faster ground speed.
- To slow the mower, gently release your thumb pressure on the ground speed control levers.

# Operating the Walk Behind Mower

## OPERATING ON A SLOPE

While it is not recommended, traveling up and down slopes may be required from time to time. These guide lines are listed for your safety.

### Traveling Up a Slope

Since the hill climbing ability of the machine will probably far exceed any other machine you may have operated, caution should be observed.

- Never make abrupt speed or directions changes on a slope.
- Never push down on the handle bars while going up a grade. A slight lifting pressure is recommended to keep the front wheels on the ground.

### Traveling Down a Slope

A very slow ground speed should always be used when traveling down a slope. This can be accomplished by GENTLY moving the ground speed control levers towards the reverse direction.

## STOPPING THE MOWER

- Returning the ground speed control levers to the neutral position will stop movement.
- Disengage the PTO.
- Release the operator presence / parking brake handles to engage the parking brake.
- Move the throttle control to mid-throttle position and turn the ignition key to OFF. Remove the key.

## MOWING

- Make sure the PTO switch is disengaged.
- Start the engine (see STARTING THE ENGINE).
- Set the throttle control to FULL.
- Grasp the operator presence / parking brake handles and the handle bar grips at the same time to deactivate engine kill system and disengage the parking brake.
- Engage the PTO by pulling up on the PTO switch.
- Begin mowing. See Lawn Care Section in the back of this manual for tips on mowing patterns, lawn care, and trouble shooting information.
- When finished, disengage the PTO.
- Stop the engine (see STOPPING THE MOWER).

## PUSHING THE MOWER BY HAND



### DO NOT TOW MOWER

Towing the unit will cause hydraulic transmission damage. Do not use another vehicle to push or pull this unit.

- Disengage the PTO, turn the ignition OFF, and remove the key.
- Slide the hydraulic release rod forward and lock into the top of the "T" slot. See Figure 2.
- Grasp the operator presence / parking brake handles and the handle bar grips at the same time to disengage the parking brake.

The mower can now be pushed by hand.

- After moving the mower, re-engage the transmission (DRIVE position) by releasing the rod from the "T" and sliding the release handle towards the rear of the machine.

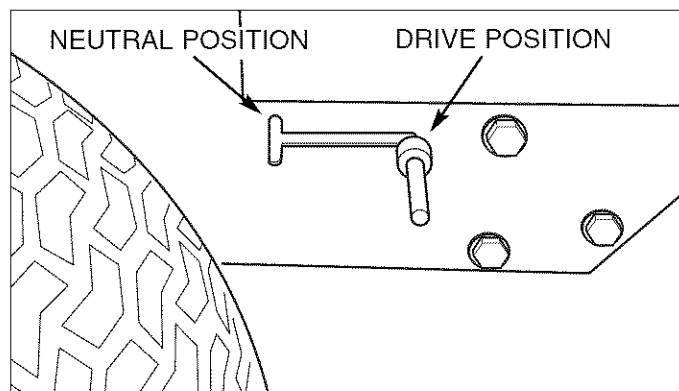

Figure 2. Hydraulic Release Rod

## STORAGE

### Temporary Storage (30 Days Or Less)

Remember, the fuel tank will still contain some gasoline, so never store the unit indoors or in any other area where fuel vapor could travel to any ignition source. Fuel vapor is also toxic if inhaled, so never store the unit in any structure used for human or animal habitation.

Here is a checklist of things to do when storing your unit temporarily or in between uses:

- Keep the unit in an area away from where children may come into contact with it. If there's any chance of unauthorized use, remove the spark plug (s) and put in a safe place. Be sure the spark plug opening is protected from foreign objects with a suitable cover.
- If the unit can't be stored on a reasonable level surface, chock the wheels.
- Clean all grass and dirt from the mower.

### Long Term Storage (Longer Than 30 Days)

Before you store your unit for the off-season, read the Maintenance and Storage instructions in the Safety Rules section, then perform the following steps:

- Drain crankcase oil while engine is hot and refill with a grade of oil that will be required when unit is used again.
- Prepare the mower deck for storage as follows:
  - a. Remove mower deck from the unit.
  - b. Clean underside of mower deck.
  - c. Coat all bare metal surfaces with paint or light coat of oil to prevent rusting.
- Clean external surfaces and engine.
- Prepare engine for storage. See engine owner's manual.
- Clean any dirt or grass from cylinder head cooling fins, engine housing and air cleaner element.
- Cover air cleaner and exhaust outlet tightly with plastic or other waterproof material to keep out moisture, dirt and insects.
- Completely grease and oil unit as outlined in the Normal Care section.
- Clean up unit and apply paint or rust preventative to any areas where paint is chipped or damaged.

## WARNING

**Never store the unit, with gasoline in engine or fuel tank, in a heated shelter or in enclosed, poorly ventilated enclosures. Gasoline fumes may reach an open flame, spark or pilot light (such as a furnace, water heater, clothes dryer, etc.) and cause an explosion.**

**Handle gasoline carefully. It is highly flammable and careless use could result in serious fire damage to your person or property.**

**Drain fuel into an approved container outdoors away from open flame or sparks.**

- Drain fuel system completely or add a gasoline stabilizer to the fuel system. If you have chosen to use a fuel stabilizer and have not drained the fuel system, follow all safety instructions and storage precautions in this manual to prevent the possibility of fire from the ignition of gasoline fumes. Remember, gasoline fumes can travel to distant sources of ignition and ignite, causing risk of explosion and fire.

*NOTE: Gasoline, if permitted to stand unused for extended periods (30 days or more), may develop gummy deposits which can adversely affect the engine carburetor and cause engine malfunction. To avoid this condition, add a gasoline stabilizer to the fuel tank and run the engine a few minutes, or drain all fuel from the unit before placing it in storage.*

## STARTING AFTER LONG TERM STORAGE

Before starting the unit after it has been stored for a long period of time, perform the following steps.

- Remove any blocks from under the unit.
- Unplug the exhaust outlet and air cleaner.
- Fill the fuel tank with fresh gasoline. See engine manual for recommendations.
- See engine owner's manual and follow all instructions for preparing engine after storage.
- Check crankcase oil level and add proper oil if necessary. If any condensation has developed during storage, drain crankcase oil and refill.
- Inflate tires to proper pressure. Check fluid levels.
- Start the engine and let it run slowly. DO NOT run at high speed immediately after starting. Be sure to run engine only outdoors or in well ventilated area.

# Regular Maintenance

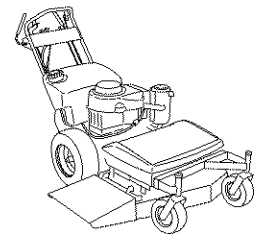

## MAINTENANCE SCHEDULE & PROCEDURES

The following schedule should be followed for normal care of your rider and mower. You will need to keep a record of your operating time. Determining operating time is easily accomplished by multiplying the time it takes to do one job by the number of times you've done the job, or you can install an hour meter.

SAFETY ITEMS	See Page	Before First Use	Before Each Use	Every 5 Hours	Every 25 Hours	Every 100 Hours	Spring & Fall
Check Safety Interlock System	7	●					●
Check Mower Blade Stopping Time	22	●				●	
NORMAL CARE ITEMS	See Page	Before First Use	Before Each Use	Every 5 Hours	Every 25 Hours	Every 100 Hours	Spring & Fall
Check Mower for loose hardware	—		●	●			
Check Engine Oil Level	13*	●	●	●			●
Check Engine Air Filter	13*		●			***●	
Change Engine Oil & Filter **	13*				***● Every 50 Hours		***●
Lubricate Mower	14					***●	
Check Tire Pressure	12	●				***●	
Check Fuel Filter	13					●	
Clean & Sharpen Mower Blades	15					●	
Inspect Spark Plug	13*					●	

\* See the engine manufacturer's owner's manual.

\*\* Change original engine oil after first 5 hours of operation.

\*\*\* More often in hot (over 85° F: 30° C) weather or dusty operating conditions.

## CHECK TIRE PRESSURE

Tire Pressure should be checked periodically, and maintained at the levels shown in the chart. Note that these pressures may differ slightly from the "Max Inflation" stamped on the side-wall of the tires. The pressures shown provide proper traction, improve cut quality, and extend tire life.

Tire	Pressure
Front	25 psi (1,72 bar)
Rear	15 psi (1,03 bar)

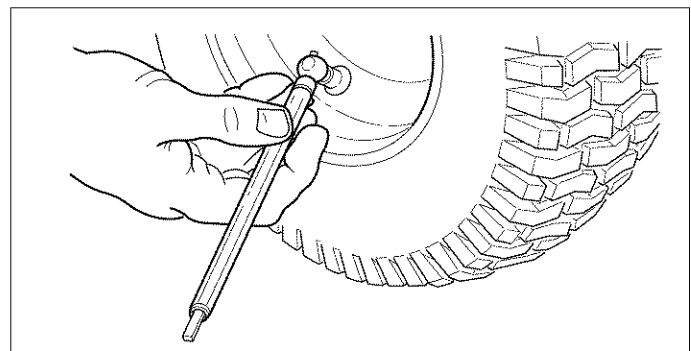

Figure 3. Checking Tire Pressure

## CHECKING / ADDING FUEL

To add fuel:

- Remove the fuel cap.
- Fill the tank.

Do not overfill. Leave approximately 1" of room in the tank for fuel expansion. Refer to your engine manual for specific fuel recommendations.

- Install and hand tighten the fuel cap.

## FUEL FILTER

The fuel filter is located in the fuel line between the fuel shut off valve and the fuel pump. If filter is dirty or clogged, replace as follows:

- Shut off the fuel valve.
- Place a container below the filter to catch spilled fuel.
- Using a pliers, open and slide hose clamps from fuel filter.
- Remove hoses from filter.
- Install new filter in proper flow direction in fuel line.
- Secure with hose clamps.

## OIL & FILTER CHANGE

1. Warm engine by running for a few minutes. (Refer to the engine operator's manual for oil & filter replacement instructions.)
2. Park machine and place the rear tires in a 2 x 4 block of wood or park machine on a slight downhill grade.
3. Place a small pan under the oil drain hose to catch the oil.
4. Using the appropriate tools, turn the oil drain valve counter-clockwise to open the valve and drain the engine oil.
5. After draining, turn the oil drain valve clockwise to close the valve and wipe up any spilled oil.
6. Place a small pan or cup under the engine oil filter.
7. Remove the engine oil filter and replace with a new one.
8. Remove the pan or cup and wipe up any spilled oil.

## CHECK / CHANGE AIR FILTER

Refer to engine owners manual.

## REPLACE SPARK PLUG

Refer to engine owners manual.

## ⚠ WARNING

Gasoline is highly flammable and must be handled with care. Never fill the tank when the engine is still hot from recent operation. Do not allow open flame, smoking or matches in the area. Avoid over-filling and wipe up any spills.

Do not remove fuel filter when engine is hot, as spilled gasoline may ignite. DO NOT spread hose clamps further than necessary. Ensure clamps grip hoses firmly over filter after installation.



Do not use gasoline containing METHANOL, gasohol containing more than 10% ethanol, gasoline additives, premium gasoline, or white gas because engine/fuel system damage could result.

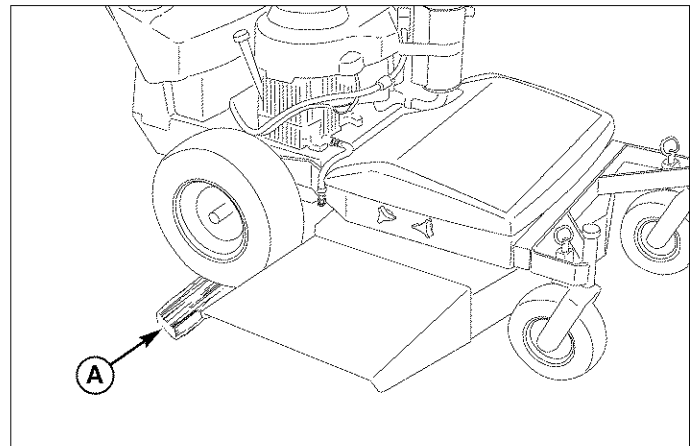

**Figure 4. Raise Rear of Machine**

A. 2 x 4 Block

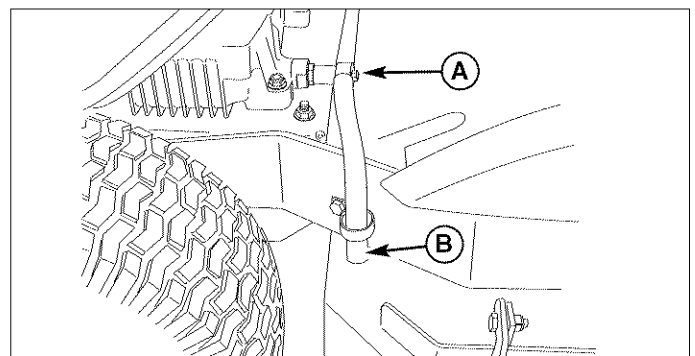

**Figure 5. Oil Drain Hose Location**

A. Oil Drain Valve  
B. Drain Hose

# Regular Maintenance

---

## LUBRICATION

Lubricate the unit at the following lubrication points.

### Grease:



- front caster wheel axles
- front caster wheel pivots
- ground speed control shaft pivot

Use grease fittings when present. Disassemble parts to apply grease to moving parts when grease fittings are not installed.

Not all greases are compatible. Ferris Red Grease (P/N 22285) is recommended, automotive-type high-temperature, lithium grease may be used when this is not available.

### Oil:



- operator presence / parking brake handle pivot
- ground speed control lever pivots
- discharge chute pivots
- cutting height adjust handle pivots
- deck lift pivots

Generally, all moving metal parts should be oiled where contact is made with other parts. Keep oil and grease off belts and pulleys. Remember to wipe fittings and surfaces clean both before and after lubrication.

## SERVICING THE MOWER BLADES

- Blades should be sharp and free of nicks and dents. If not, sharpen blades as described in following steps.
- To remove blade for sharpening, use a 1" wrench on the flats of the spindle shaft while removing the blade mounting bolt with a 15/16" wrench (Figure 6).
- Use a file to sharpen blade to fine edge. Remove all nicks and dents in blade edge. If blade is severely damaged, it should be replaced.
- Balance the blade as shown in Figure 7. Center the blade's hole on a nail lubricated with a drop of oil. A balanced blade will remain level.
- Reinstall each blade with the tabs pointing up toward deck as shown in Figure 8. Secure with a bolt and flat washer and torque bolts to 70 ft.lbs. (94 N.m.).

### WARNING

Mower blades are sharp. For your personal safety, do not handle mower blades with bare hands. Careless or improper handling of blades may result in serious injury. For your personal safety, blade mounting bolts must each be installed with a flat washer then securely tightened. Torque blade mounting bolts to 70 ft.lbs. (94 N.m.)

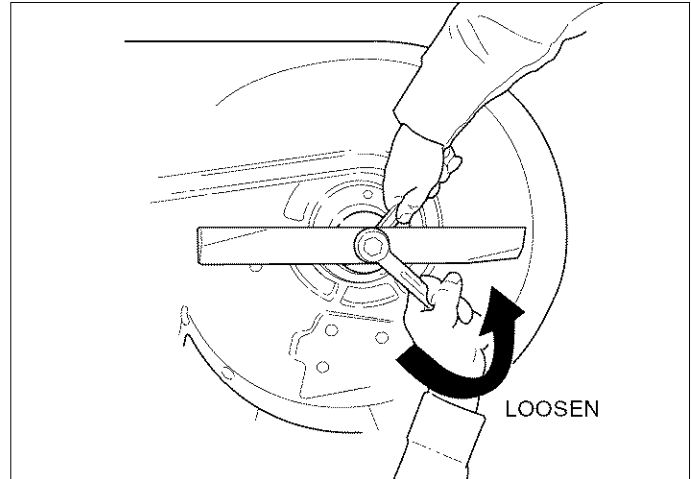

Figure 6. Removing the Blade

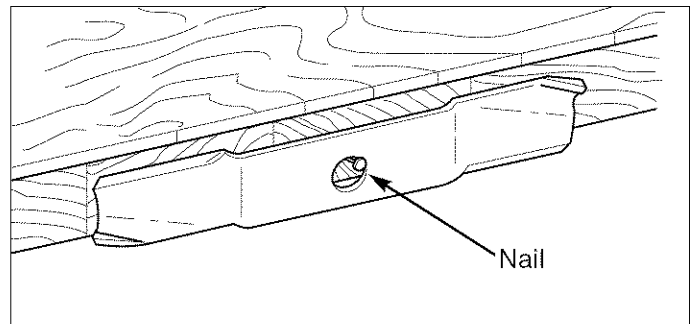

Figure 7. Balancing The Blade

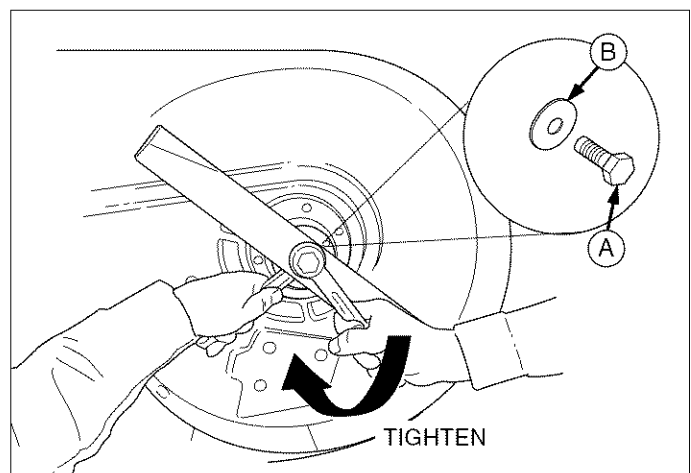
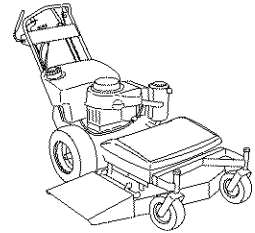

Figure 8. Installing The Blade

- A. Bolt
- B. Flat Washer

# Troubleshooting Adjustments & Service



## TROUBLESHOOTING

While normal care and regular maintenance will extend the life of your equipment, prolonged or constant use may eventually require that service be performed to allow it to continue operating properly.

The troubleshooting guide below lists the most common problems, their causes and remedies.

See the information on the following pages for instructions on how to perform most of these minor adjustments and service repairs yourself. If you prefer, all of these procedures can be performed for you by your local authorized dealer.

### WARNING

**To avoid serious injury, perform maintenance on the tractor or mower only when the engine is stopped and the parking brake engaged.**

**Always remove the ignition key, disconnect the spark plug wire and fasten it away from the plug before beginning the maintenance, to prevent accidental starting of the engine.**

## TROUBLESHOOTING THE MOWER

PROBLEM	CAUSE	REMEDY
Engine will not turnover or start.	<ol style="list-style-type: none"> <li>PTO (electric clutch) switch in ON position.</li> <li>Out of fuel.</li> <li>Engine flooded.</li> <li>Wiring loose or broken.</li> <li>Safety interlock switch faulty.</li> <li>Spark plug(s) faulty, fouled or incorrectly gapped.</li> <li>Water in fuel.</li> <li>Gas is old or stale.</li> </ol>	<ol style="list-style-type: none"> <li>Place in OFF position.</li> <li>If engine is hot, allow it to cool, then refill the fuel tank.</li> <li>Move throttle control out of CHOKE position.</li> <li>Visually check wiring &amp; replace broken or frayed wires. Tighten loose connections.</li> <li>Replace as needed. See authorized service dealer.</li> <li>Clean and gap or replace. See engine manual.</li> <li>Drain fuel &amp; refill with fresh fuel.</li> <li>Drain fuel &amp; replace with fresh fuel.</li> </ol>
Engine starts hard or runs poorly.	<ol style="list-style-type: none"> <li>Fuel mixture too rich.</li> <li>Spark plug faulty, fouled, or incorrectly gapped.</li> </ol>	<ol style="list-style-type: none"> <li>Clean air filter. Check choke adjustment (throttle control).</li> <li>Clean and gap or replace. (See engine manual.)</li> </ol>
Engine knocks.	<ol style="list-style-type: none"> <li>Low oil level.</li> <li>Using wrong grade oil.</li> </ol>	<ol style="list-style-type: none"> <li>Check/add oil as required.</li> <li>See engine manual.</li> </ol>
Excessive oil consumption.	<ol style="list-style-type: none"> <li>Engine running too hot.</li> <li>Using wrong weight oil.</li> <li>Too much oil in crankcase.</li> </ol>	<ol style="list-style-type: none"> <li>Clean engine fins, blower screen and air cleaner.</li> <li>See engine manual.</li> <li>Drain excess oil.</li> </ol>
Engine exhaust is black.	<ol style="list-style-type: none"> <li>Dirty air filter.</li> <li>Engine choke control is in closed position.</li> </ol>	<ol style="list-style-type: none"> <li>Replace air filter. See engine manual.</li> <li>Open choke control.</li> </ol>
Engine runs, but mower will not drive.	<ol style="list-style-type: none"> <li>Hydraulic release valve rod in "open" position.</li> <li>Belt is broken.</li> <li>Drive belt slips.</li> <li>Brake is not fully released.</li> </ol>	<ol style="list-style-type: none"> <li>Return release rod to DRIVE position.</li> <li>See Drive Belt Replacement.</li> <li>See problem and cause below.</li> <li>See authorized service dealer</li> </ol>
Brake will not hold.	<ol style="list-style-type: none"> <li>Brake is incorrectly adjusted.</li> </ol>	<ol style="list-style-type: none"> <li>See authorized service dealer.</li> </ol>
Mower drives or handles poorly.	<ol style="list-style-type: none"> <li>Loose control linkages.</li> <li>Improper tire inflation.</li> </ol>	<ol style="list-style-type: none"> <li>Check and tighten any loose connections.</li> <li>See Regular Maintenance Section.</li> </ol>



## TROUBLESHOOTING THE MOWER DECK

PROBLEM	CAUSE	REMEDY
<b>Mower drive belt slips or fails to drive.</b>	<ol style="list-style-type: none"><li>1. Clutch is out of adjustment.</li><li>2. Pulleys or belt greasy or oily.</li><li>3. Idler pulley spring broken or not properly attached.</li><li>4. Belt stretched or worn.</li><li>5. Mower drive belt broken.</li></ol>	<ol style="list-style-type: none"><li>1. See PTO CLutch Adjustment Section.</li><li>2. Clean as required.</li><li>3. Repair or replace as needed.</li><li>4. Replace drive belt.</li><li>5. Replace drive belt.</li></ol>
<b>Mower cut is uneven.</b>	<ol style="list-style-type: none"><li>1. Mower not leveled properly.</li><li>2. Drive tires not inflated equally or properly.</li></ol>	<ol style="list-style-type: none"><li>1. See Mower Adjustment.</li><li>2. See Regular Maintenance Section.</li></ol>
<b>Mower cut is rough looking.</b>	<ol style="list-style-type: none"><li>1. Engine speed too slow.</li><li>2. Ground speed too fast.</li><li>3. Blades are dull.</li><li>4. Mower drive belt slipping because it is oily or worn.</li><li>5. Blades not properly fastened to arbors.</li></ol>	<ol style="list-style-type: none"><li>1. Set throttle to full.</li><li>2. Decrease Ground Speed.</li><li>3. Sharpen or replace blades. See Mower Blade Service.</li><li>4. Clean or replace belt as necessary.</li><li>5. See Servicing the Mower Blades.</li></ol>
<b>Engine stalls easily with mower engaged.</b>	<ol style="list-style-type: none"><li>1. Engine speed too slow.</li><li>2. Ground speed too fast.</li><li>3. Cutting height set too low.</li><li>4. Discharge chute plugged with cut grass.</li></ol>	<ol style="list-style-type: none"><li>1. Set to full throttle.</li><li>2. Decrease Ground Speed.</li><li>3. Cut tall grass at maximum cutting height during first pass.</li><li>4. Cut grass with discharge pointing toward previously cut area.</li></ol>
<b>Excessive mower vibration.</b>	<ol style="list-style-type: none"><li>1. Blade mounting screws are loose.</li><li>2. Mower blades, arbors, or pulleys are bent.</li><li>3. Mower blades are out of balance.</li><li>4. Belt installed incorrectly.</li></ol>	<ol style="list-style-type: none"><li>1. Tighten to 70 ft.lbs. (94 N.m.).</li><li>2. Check and replace as necessary.</li><li>3. Remove, sharpen, and balance blades. See Maintenance Section.</li><li>4. Reinstall Correctly.</li></ol>
<b>Excessive belt wear or breakage.</b>	<ol style="list-style-type: none"><li>1. Bent or rough pulleys.</li><li>2. Using incorrect belt.</li></ol>	<ol style="list-style-type: none"><li>1. Repair or replace.</li><li>2. Replace with correct belt.</li></ol>

## CUTTING HEIGHT ADJUSTMENT

The cutting height can be adjusted within two different ranges. The High Range covers 4-1/2" - 2-1/2" (11,4 - 6,4cm) and the Low Range covers 3-1/2" - 1-1/2" (8,9 - 3,8cm). See Figure 9 for deck height indicator.

Before adjusting the cutting height, you must first determine the average cutting height. Depending on the range you plan to use, it may be necessary to adjust the deck lift pivot locations and the pulley spacer positions. See Figures 10 & 11 for pulley and pivot positions in relation to the cutting range.

### To Adjust the Cutting Range:

1. Remove the mower deck drive belt. See Belt Removal & Replacement Section for proper procedure.
2. Remove the spindle nut (B, Figure 11) fastening the pulley to the spindle. Remove the pulley and key. Move the pulley spacers into the proper position in relation to the cutting range. Reinstall the pulley and key. Reinstall the nut and torque to 85-90 ft. lbs. (115-122 Nm).
3. Remove the pivot bolts and nuts (A, Figure 11) and reinstall the proper position in relation to the cutting range. Reinstall the bolts and nuts and tighten securely.

### To Adjust the Cutting Height:

Turn the crank handle clockwise to raise the mower deck or counterclockwise to lower the mower deck. See Figure 12.

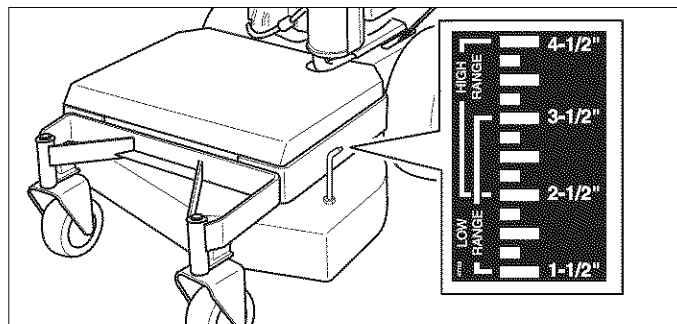

Figure 9. Deck Height Indicator

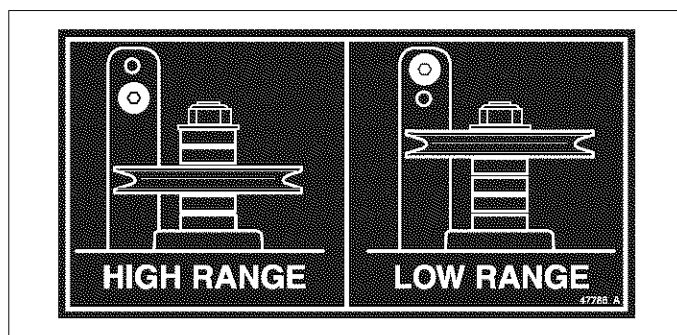

Figure 10. Pulley & Pivot Position

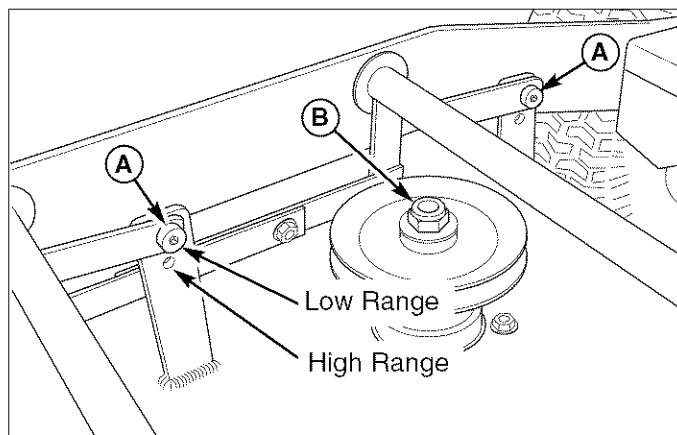

Figure 11. Pulley & Pivot Position

- A. Pivot Bolts & Nuts
- B. Spindle Nut

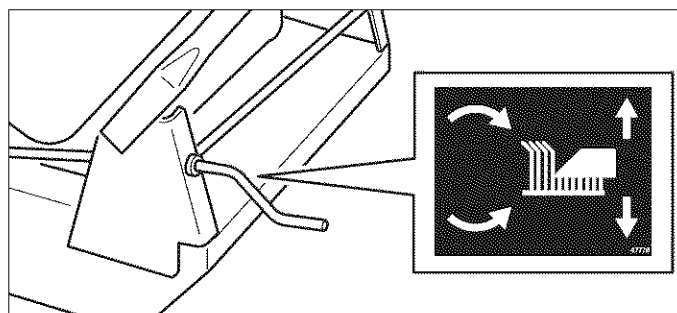

Figure 12. Cutting Height Adjustment

## DECK LEVELING ADJUSTMENT

### To Level the Mower Deck:

1. Park machine on a flat, level surface.
2. Raise the mower deck until it reaches the upper stop.
- 3A. If the mower deck is in the HIGH RANGE, place 2 x 4 blocks under the outside edges of the mower deck with the 3-1/2" sides being vertical. Place a 1/8" (3mm) thick spacer on top of the rear 2 x 4 blocks. (See Figure 13)
- 3B. If the mower deck is in the LOW RANGE, place 2 x 4 blocks under the outside edges of the mower deck with the 1-1/2" sides being vertical. Place a 1/8" (3mm) thick spacer on top of the rear 2 x 4 blocks. (See Figure 13)
4. Lower the mower deck until the deck rests against the 2 x 4 blocks and spacers.
5. Loosen the bolts (A, Figure 14) that secure the connecting links (B) together. This will remove any tension from the mounting linkages and pivots.
6. Retighten the bolts securely.
7. Verify that the deck height indicator (C) is aligned with the 4" mark (if in the HIGH RANGE) or the 2" mark (if in the LOW RANGE). Adjust the indicator position if necessary.
8. Remove the blocks from under the mower deck.

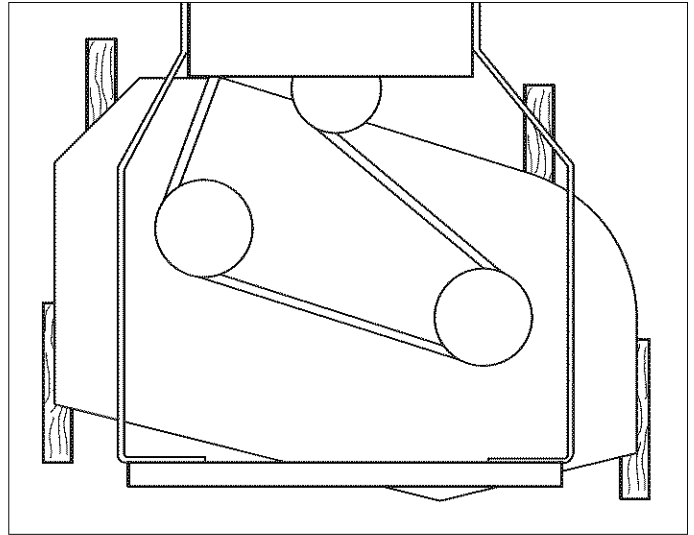

Figure 13. 2 x 4 Placement

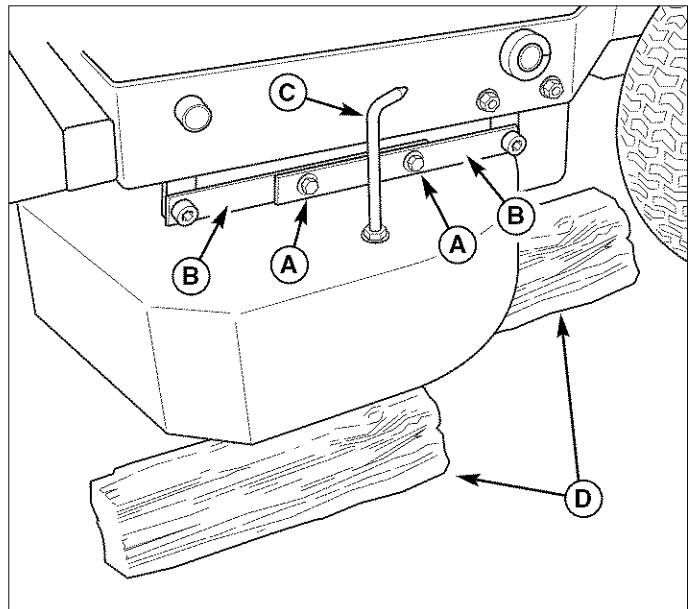

Figure 14. Deck Leveling Linkages

- A. Linkage Bolts
- B. Connecting Links
- C. Deck Height Indicator
- D. 2 x 4 Blocks

## BELT REMOVAL AND REPLACEMENT

### Mower Deck Drive Belt:

1. Park machine on a flat, level surface.
2. Remove the mower deck shield.
3. Push the idler arm towards the left-hand side of the machine to release the spring tension on the drive belt. (See Figure 15)
4. Slide the drive belt over the edge of the idler pulley (A). Release the idler arm.
5. Remove the old belt and replace with a new one. Make sure the V-side of the belt runs in the pulley grooves.
6. Install the drive belt on the spindle pulleys and the PTO clutch pulley. Again, push the idler arm towards the left-hand side of the machine and install the belt onto the idler pulley (A).
7. Run the mower under no-load condition for about 5 minutes to break in the belt.

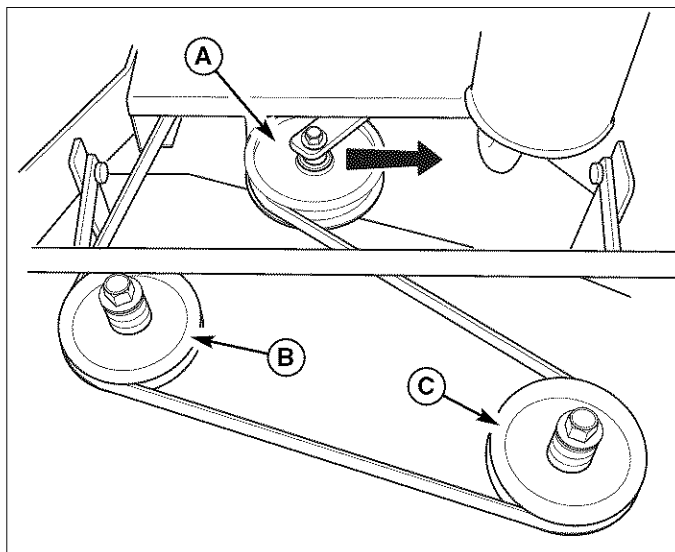
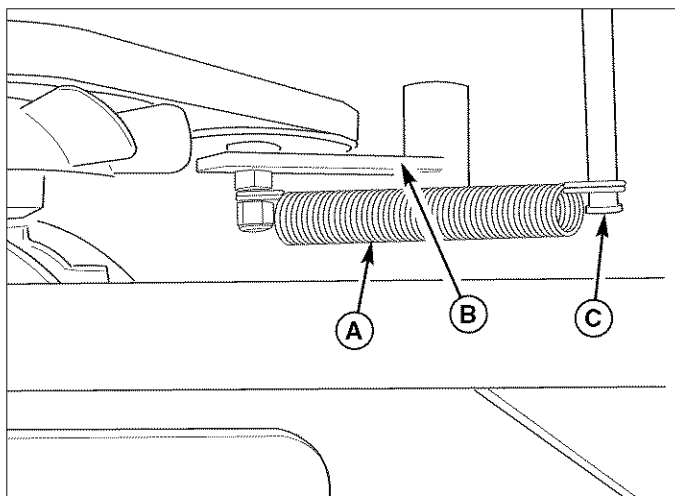

**Figure 15. Mower Deck Drive Belt**

- A. Idler Pulley
- B. Right-Hand Spindle Pulley
- C. Left-Hand Spindle Pulley

### Transaxle Drive Belt:

1. Park machine on a flat, level surface.
2. Remove the rear shield.
3. Remove the mower deck drive belt from the PTO clutch. See instructions above.
4. With a steel coat hanger, form a small hook. Insert the coat hanger through the opening in the right-hand side of the engine deck. Use the coat hanger to remove the spring (A, Figure 16) from the anchor pin (C).
5. Remove the belt from the idler pulley. Then remove the belt from the transaxle drive pulley and pull towards front of machine. Remove the belt from the drive pulley on the engine and drop belt around the PTO clutch to completely remove from machine.
6. Replace the old belt with a new belt. Install the new belt around the PTO clutch and onto the drive pulley on the engine. Reinstall belt onto the transaxle drive pulley and then onto the idler pulley. Make sure the V-side of the belt runs in the pulley grooves.
7. Using the coat hanger, reinstall the spring onto the anchor pin.
8. Reinstall the rear shield.



**Figure 16. Transaxle Drive Belt**

- B. Spring
- C. Drive Idler Arm
- C. Anchor Pin

## GROUND SPEED CONTROL LEVER LOCATION ADJUSTMENT

The control levers can be adjusted in two ways to provide a comfortable working range when operating the machine at the average mowing speed.

Adjust both the lever height and lever position at the same time to obtain the most comfortable working position.

### Adjusting the Lever Height:

1. Loosen the lever fastener (B, Figure 17) to adjust the lever height. Make sure the levers are parallel with the handle bars in both forward and reverse without contacting the handle bars.

### Adjusting the Lever Position:

1. Remove the hairpin and clevis pin (D) that fasten the control rod (E) to the lever pivot (C).
2. Loosen the jam nut and adjust the position of the clevis on the rod. By shortening the rod (turning the clevis clockwise), it will move the lever forward. By lengthening the rod (turning the clevis counter-clockwise), it will move the lever rearward. Adjust until the desired lever position is obtained and tighten the jam nuts.
3. Reinstall the clevis on the lever pivot and secure with the clevis pin and hairpin.

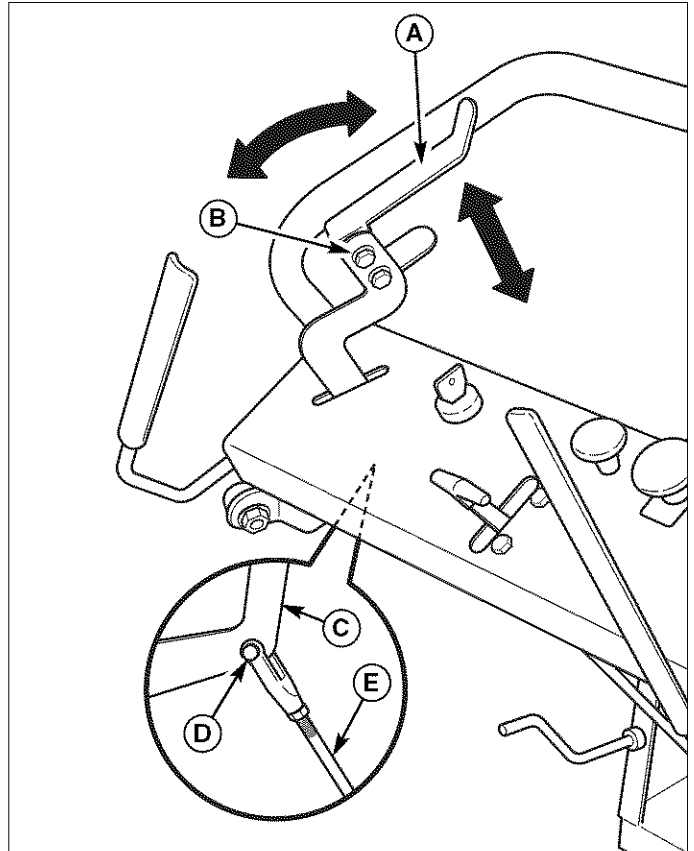

**Figure 17. Ground Speed Control Lever Adjustment**

- A. Control Lever
- B. Lever Fastener
- C. Lever Pivot
- D. Clevis Pin & Hairpin
- E. Control Rod

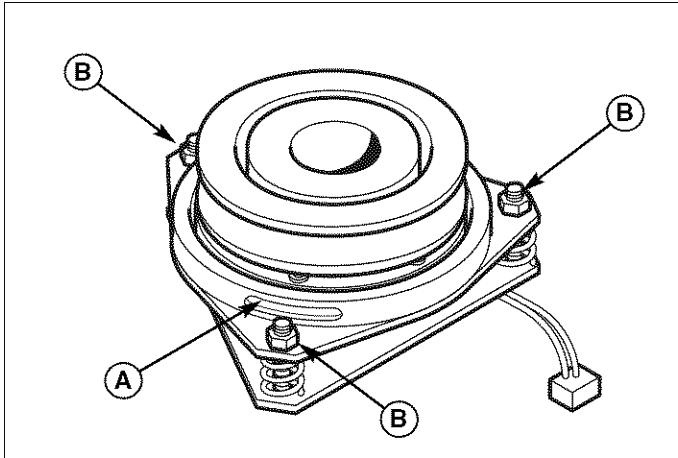

**Figure 18. PTO Clutch Adjustment**

- A. Adjustment Window (Qty. 3, one shown)
- B. Adjustment Nut

## PTO CLUTCH ADJUSTMENT

Check the PTO clutch adjustment after the initial 50 hour break-in period and then after every 250 hours of operation. Also perform the following procedure if the clutch is slipping or will not engage, or if a new clutch has been installed.

- Remove key from ignition switch and disconnect spark plug wires to prevent the possibility of accidental starting while the PTO is being adjusted.
- See Figure 18. Note the position of the 3 adjustment windows (A) in the side of the brake plate and the nylock adjustment nuts (B).
- Insert a .016"-.018" (0,40-0,45mm) feeler gauge (C) through each window, positioning the gauge between the rotor face and the armature face as shown in Figure 19.
- Alternately tighten the adjustment nuts (B, Figure 18) until the rotor face and armature face just contacts the gauge.
- Check the windows for an equal amount of tension when the gauge is inserted and removed, and make any necessary adjustments by tightening or loosening the adjustment nuts.

*NOTE: The actual air gap between the rotor and armature may vary even after performing the adjustment procedure. This is due to dimensional variations on component parts, and is an acceptable condition.*

- Check the mower blade stopping time. The mower blades and mower drive belt should come to a complete stop within five seconds after the electric PTO switch is turned off.

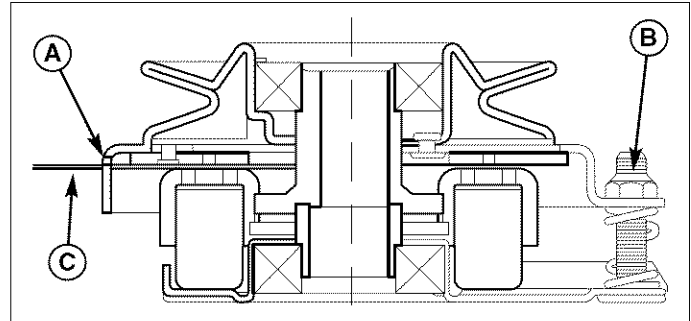

**Figure 19. Adjust PTO Clutch**

- A. Window
- B. Adjustment Nut
- C. .016"-.018" (0,40-0,45mm) Feeler Gauge

## **⚠ WARNING**

**To avoid serious injury, perform adjustments only with engine stopped, key removed and tractor on level ground.**

## Blade Brake Check

Mower blades and mower drive belt should come to a complete stop within five seconds after electric PTO switch is turned off.

- With PTO disengaged, start the engine.
- Remove the mower deck guard and observe the mower drive belt. Engage the PTO and wait several seconds. Disengage the PTO and check the amount of time it takes for the mower drive belt to stop.
- If the mower drive belt does not stop within five seconds, perform the PTO Clutch Adjustment. If the belt still does not stop within 5 seconds, see your dealer.

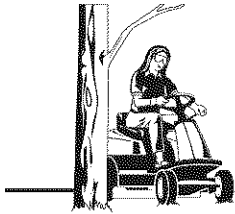

# Lawn Care & Mowing Information

## GENERAL INFORMATION

Proper mowing is an important part of maintaining your lawn in the best possible condition. A healthy and well maintained lawn is better able to resist drought, weeds, and other stresses. But too much maintenance is as detrimental to your lawn as neglect. Proper care for your lawn involves more than just "cutting the grass." To have a healthy lawn, you need to know:

- Types of Grass, Climate and Conditions
- How and When to Water, Fertilize & Aerate
- How High to Mow the Grass
- When and How Often to Mow
- What Mowing Patterns to Use
- Proper Mowing Methods
- How to Solve Common Mowing Problems

## TYPES OF GRASS, CLIMATE AND CONDITIONS

A variety of grasses are commonly grown in household lawns, but two main groups known as cool-season grasses (varieties of bluegrass, ryegrass, and fescue), and warm-season grasses (typically bermuda, buffalo grass, and zoysia varieties) are the most common.

The cool-season grasses are better suited to cooler climates, and do not endure hot and dry weather as well as warm-season grasses, but conversely, the warm-season grasses do not grow as well in cooler climates. Most residential lawns are typically seeded with a mixture of these grasses. (A local nursery or lawn center may help you to identify what kind of grass your lawn contains from a sample.)

Knowing your climate and conditions is also important to proper lawn care. Drier climates or conditions will require additional watering, while wetter climates may require more frequent mowing.

## HOW AND WHEN TO WATER, FERTILIZE & AERATE

Every lawn's watering needs are unique and are dependent upon the type of grass and soil, the amount of local rainfall, and other conditions. **Most lawns are watered too often, but with too little water.** However too much water can allow development of diseases with your lawn. **It is best to water the lawn only when necessary, and then to water it slowly, evenly, and deeply—imitating a slow, soaking rain.**

### WHEN TO WATER YOUR LAWN

When the lawn begins to wilt, the grass's color dulls, or footprints stay compressed for more than a few seconds, the lawn is beginning to dry out, and needs additional moisture. The best time to water is early morning to allow the water to soak deeply into the lawn and reduce the amount that evaporates in the hot afternoon sun.

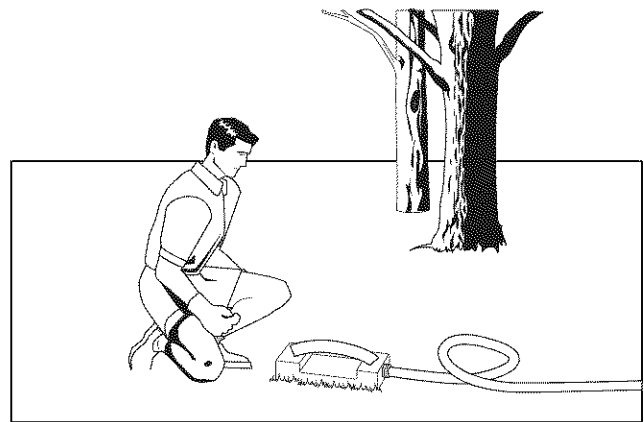

### HOW TO WATER YOUR LAWN

The best method of watering a lawn is to imitate a slow, soaking rain, applying about 1 inch of water. A method of verifying the amount that you have watered, is to place several empty tin cans (low shallow cans work best) in various spots around the lawn, and check the depth of water in the can during the watering process.

### HOW TO FERTILIZE YOUR LAWN

Fertilizing with a slow-release fertilizer provides missing nutrients which help create slow, even growth. While opinions vary on the need for fertilizing, when and how much to fertilize will be more a factor of the condition of the lawn and soil than any routine. Remember that over-fertilizing can cause harm, and that most fertilizing should be applied in the spring so that it will release into the lawn through the summer. For more information, check with a local nursery or lawn care specialist, and read and follow the fertilizer manufacturer's instructions.

### AERATING YOUR LAWN

Consider aerating your lawn in spring. Using an aerator to remove cores of soil from the lawn increases the speed of clipping decomposition and encourages deeper root growth by opening up the soil and permitting greater movement of water, fertilizer and air.

# Lawn Care & Mowing Information

## HOW HIGH TO MOW THE GRASS

Often cutting height is a matter of personal preference. Typically, you should mow the grass when it is between three and five inches high. The proper cutting height range for a specific lawn will depend upon several factors, including the type of grass, the amount of rainfall, the prevailing temperature, and the lawn's overall condition.

Cutting the grass too short causes weak, thin grass plants, which are easily damaged by dry periods and pests. Cutting too short is often more damaging than allowing the grass to be slightly higher.

Letting grass grow a bit longer—especially when it is hot and dry—reduces heat build-up, preserves needed moisture and protects the grass from heat damage and other problems. However, allowing grass to grow too high can cause thin turf and additional problems.

Cutting off too much at one time shocks the plant's growth system and weakens the grass plants. **A good rule of thumb is the 1/3 rule: to cut no more than one third of the grass height, and never more than 1 inch at a time.**

The amount of grass you are able to cut in one pass is also effected by the type of mowing system you are using (for example, broadcasting with side discharge decks can process a much larger volume of grass than mulching does).

*NOTE: We cover some specific mowing instructions for mulching and broadcasting later in this Lawn Care section.*

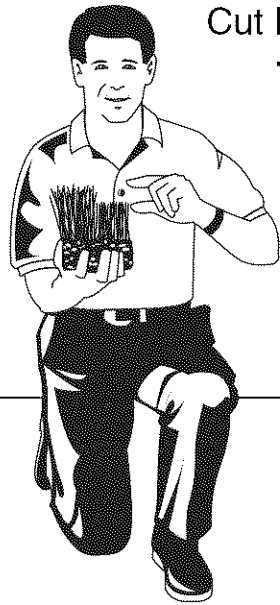

Cut less than  
**1/3**

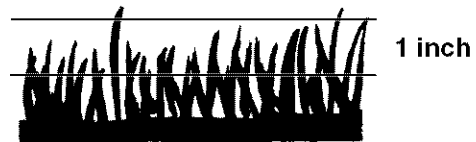
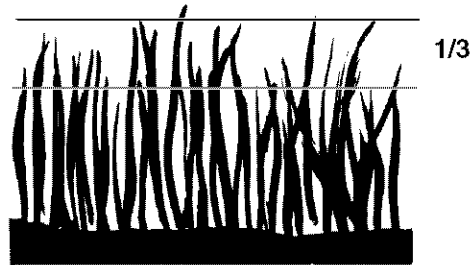
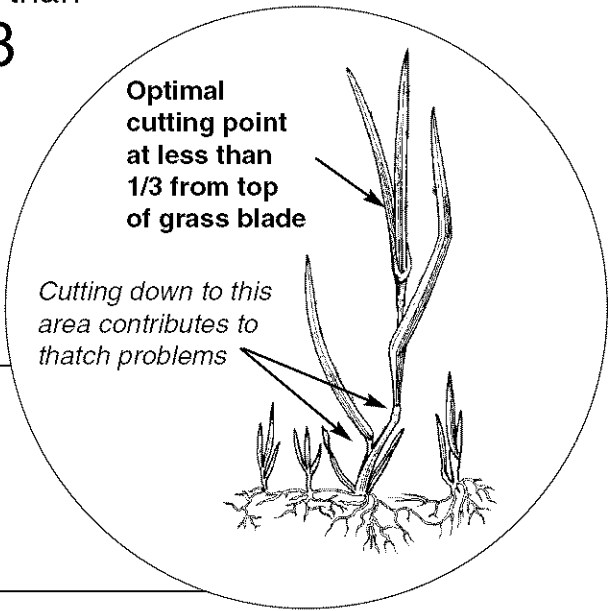

**Proper Cutting Height**

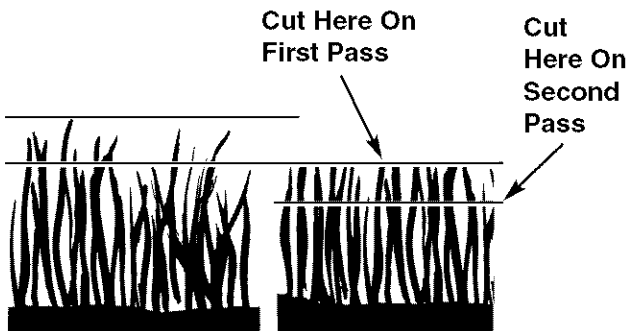

### Tall Grass Requires Incremental Cutting

For extremely tall grass, set the cutting height at maximum for the first pass, and then reset it to the desired height and mow a second or third time.

Don't cover the grass surface with a heavy layer of clippings. Consider using a grass collection system and starting a compost pile.



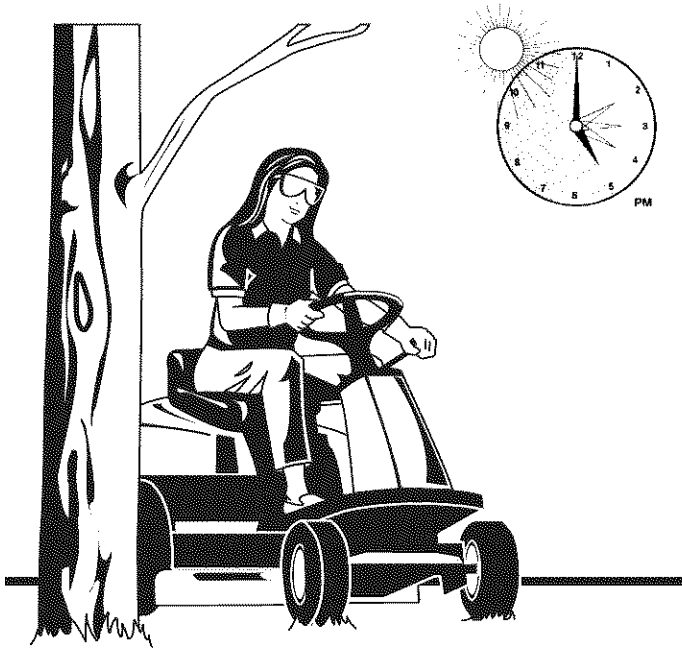

## WHEN AND HOW OFTEN TO MOW

The time of day and condition of the grass greatly affect the results you'll get when mowing. For the best results, follow these guidelines:

- I Mow when the grass is between three and five inches high.
- I Mow with sharp blades. Short clippings of grass one inch or shorter decompose more quickly than longer blades. Sharp mower blades cut grass cleanly and efficiently, preventing frayed edges which harm the grass.
- I Mow at time of day when the grass is cool and dry. Late afternoon or early evening often provide these ideal mowing conditions.
- I Avoid mowing after rain or even heavy dew, and never mulch when the grass is wet (moist grass does not mulch well, and clumps beneath the mower deck).

## WHAT MOWING PATTERNS TO USE

Always start mowing on a smooth, level area.

The size and type of area to be mowed will determine the best mowing pattern to use. Obstructions such as trees, fences and buildings, and conditions such as slopes and grades must also be considered.

- I Cut long straight strips overlapping slightly.
- I Where possible, change patterns occasionally to eliminate matting, graining or a corrugated appearance.
- I For a truly professional cut, mow across the lawn in one direction, then recut the lawn by mowing perpendicular to the previous cut.

*Where possible, make one or two passes around the outside of the area discharging the grass INTO the lawn to keep the cut grass off fences and walks.*

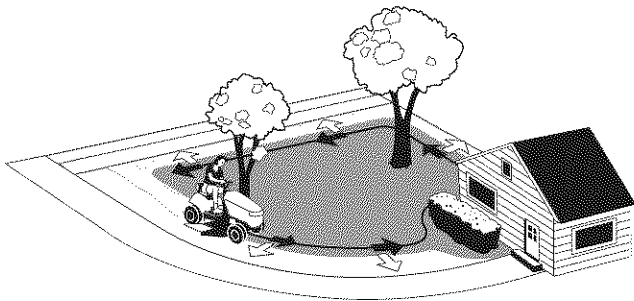
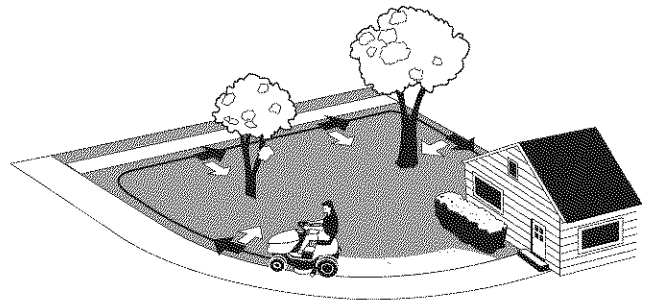

*The remainder of the mowing should be done in the opposite direction so that the clippings are dispersed OUT onto the area of lawn previously cut.*

**Note: Always operate the engine at full throttle when mowing.**

If you hear the engine slowing down, you are mowing too fast—using a slower ground speed will improve the cutting efficiency of the blades and prevents many common cutting problems. Use an appropriate ground speed for the thickness and height of the grass you are cutting (3rd gear or slower for manual gear models). If you hear the engine slowing down you are mowing too fast, use a slower ground speed.

# Lawn Care & Mowing Information

---

## MOWING METHODS

---

### Proper Broadcast Mowing

Broadcasting, or side-discharging, disperses fine clippings evenly over the entire lawn. Many golf courses use this method. Your mower has a deep dish deck to allow freer circulation of clippings so they are broadcast evenly over the lawn.

#### ENGINE SPEED & GROUND SPEED FOR BROADCASTING

Always operate the engine at full throttle when mowing. If you hear the engine slowing down, you are mowing too fast—using a slower ground speed will improve the cutting efficiency of the blades and prevents many common cutting problems.

ALWAYS use an appropriate ground speed for the thickness and height of the grass you are cutting (3rd gear or slower for manual gear models). If you hear the engine



slowing down you are mowing too fast, use a slower ground speed.

#### HOW MUCH GRASS TO CUT OFF WHEN BROADCASTING

Mow when the grass is 3-5 inches long. Do not cut the grass shorter than 2 to 2-1/2 inches. Do not cut off more than 1 inch of grass in a single pass.

### Proper Mulching

Mulching consists of a mower deck which cuts and recuts clippings into tiny particles and which then blows them down INTO the lawn. These tiny particles decompose rapidly into by-products your lawn can use.

#### UNDER PROPER CONDI-

**TIONS**, your mulching mower will virtually eliminate noticeable clippings on the lawn surface.

NOTE: When mulching under heavy cutting conditions, a rumbling sound may be present and is normal.

#### MULCHING REQUIRES EXCELLENT MOWING CONDITIONS

Mulching mowers cannot function properly if the grass is wet, or if the grass is simply high to cut. Even more than normal mowing, mulching requires that the grass be dry and the appropriate amount is cut.

Do not use the mower as a mulching mower during the first two or three mowings in the spring. The long grass blades, quick growth, and often wetter conditions are more suitable for broadcasting (side-discharging) or grass bagging operation.

#### ENGINE SPEED & GROUND SPEED FOR BROADCASTING

Use full engine throttle matched with a slow ground speed so that clippings will be finely cut. Ground speed while mulching should be HALF of the speed that would be used when broadcasting (side discharging) under similar conditions. Since mulching requires more horsepower than broadcasting, using a slower ground speed is vitally important for proper mulching operation.

Mulching Action

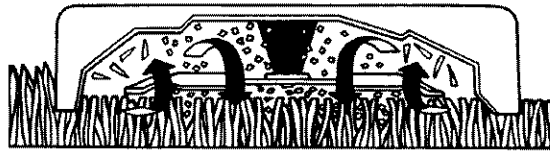

#### HOW MUCH GRASS TO MULCH

The best mulching action typically results from cutting only the top 1/2 inch to 3/4 inch of grass blade. This provides short clippings which decompose properly (much more quickly than longer clippings). The ideal cutting

height will vary with climate, time of year, and quality of your lawn. We recommend that you experiment with both the cutting height and ground speed until you achieve the best cut. Start with a high cutting height and using progressively lower settings until you find a cutting height that is matched to your mowing conditions and preferences.

### TIPS On Dealing With Clippings

Clippings are **beneficial** to your lawn. A common misconception about clippings is that they automatically lead to thatch—this is untrue. Short clippings produced by broadcasting and clippings produced by mulching methods actually **contribute to a healthy lawn** because they:

- Reduce the evaporation of water from your lawn.
- Provide a cushioning layer to reduce lawn wear.
- Moderate soil temperature.
- Clippings act as a safe, non-polluting and inexpensive fertilizer that nourishes your lawn. Fresh cut grass blades are 85% water, and are a rich source of nitrogen which is essential to lush growth. And one garbage bag of clippings contains about 1/4 lb. of usable organic nitrogen.

## COMPOSTING

The best way to recycle excess clippings and leave your lawn looking immaculate is to collect them with an efficient collection system and deposit them in a compost pile. A compost pile is a collection of grass, leaves, and other organic wastes which—when properly tended—decompose into an odorless, topsoil material. This material, in turn, acts as an inexpensive fertilizer for your lawn and garden.

### How to start a healthy compost pile:

- 1 Build a bin using bricks, fencing, cement blocks, etc. or purchase a prefabricated bin from a garden store. The bin should also have venting on each side and from the bottom to the top.
- 2 Fill the bin with alternating layers of yard waste. Follow this recipe:

First layer: 3-4 inches of chopped brush or other coarse material.

Second layer: 6-8 inches of mixed leaves, grass clippings, sawdust, etc. Materials should be "sponge damp."

Third layer: 1 inch of soil to add micro-organisms that help break down organic matter.

Fourth layer: 1-2 inches of manure to provide the nitrogen needed by micro-organisms.

Keep adding layers until the bin is almost full. Top off with a 4-6 inch layer of straw and scoop out a "basin" to catch rain water.

- 3 Four or five days later the pile will reach temperatures of 140-160 degrees. At this time you'll notice it settling, a good sign your compost is working properly.
- 4 After 5-6 weeks, fork materials into a new pile, turning the outside of the old heap into the center of the new one. Add water if necessary. The compost should be ready to use within three to four months when dark brown, crumbly, and earthy-smelling.



# Lawn Care & Mowing Information

---

## SOLUTIONS FOR COMMON MOWING PROBLEMS

### Streaking

Streaking is when thin strips of uncut grass are left behind the mower. Streaking is usually caused by operator error or poor blade maintenance.

### Streaking

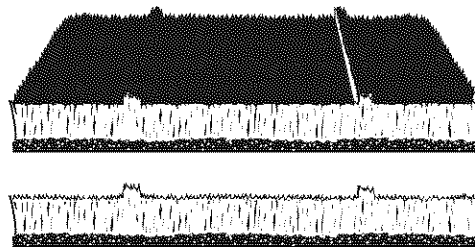

#### CAUSE

- Blades are not sharp
- Blades are worn down too far
- Engine speed is too slow
- Ground speed is too fast
- Deck is plugged with grass
- Not overlapping cutting rows enough
- Not overlapping enough when turning

#### SOLUTION

- Sharpen your blades
- Replace your blades
- Always mow at full throttle
- Slow down
- Clean out the mower
- Overlap your cutting rows
- When turning your effective cutting width decreases—overlap more when turning

---

### Stepped Cutting

Stepped cutting is sharp ridges or uneven levels left in the lawn surface. Stepped cutting is usually caused by mower deck damage or misadjustment, or damage to mower blades.

### Stepped Cutting

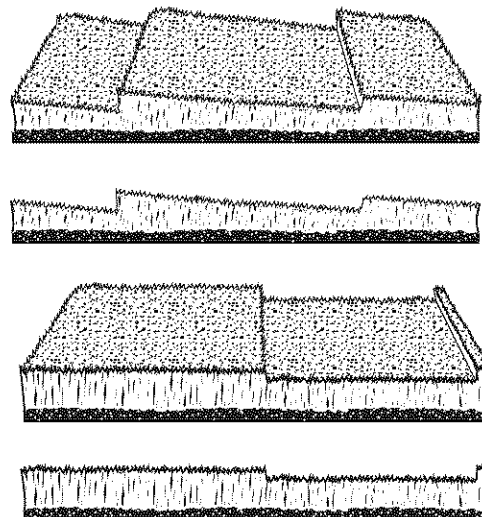

#### CAUSE

- Deck is not leveled correctly
- Tires are not properly inflated
- Blades are damaged
- Deck shell is damaged
- Mower spindle is bent or loose
- Blades are installed incorrectly

#### SOLUTION

- Level the deck correctly
- Check and inflate the tires
- Replace the blades
- Repair or replace the deck
- Repair or replace the spindle
- Reinstall the blades correctly

# Lawn Care & Mowing Information

## Uneven Cutting

Uneven cutting is waviness or smooth troughs in the lawn surface. Uneven cutting is usually caused by mower deck damage or misadjustment.

## Uneven Cutting

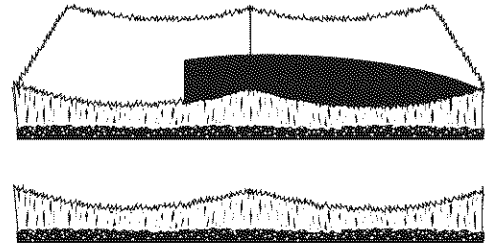

### CAUSE

- Deck is not leveled correctly
- Blades are dull or worn
- Blades are damaged
- Deck is clogged with grass clippings
- Deck shell is damaged
- Mower spindle is bent or loose
- Blades are installed incorrectly

### SOLUTION

- Level the deck correctly
- Sharpen or replace the blades
- Replace the blades
- Clean out the deck
- Repair or replace the deck
- Repair or replace the spindle
- Reinstall the blades correctly

## Scalping

Scalping is when the mower deck comes close to or hits the ground. Scalping can be caused by the mower deck misadjustment, unevenness in the lawn, or by mower deck bouncing because the ground speed is too fast.

## Scalping

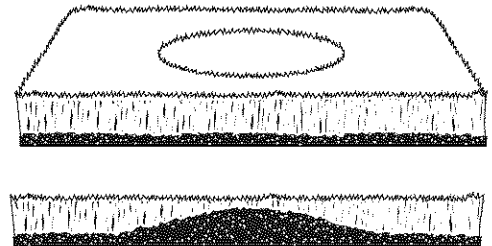

### CAUSE

- Lawn is uneven or bumpy
- Mower deck cutting height is set too low
- Ground speed is too fast
- Deck is not leveled correctly
- Tire pressure is low or uneven

### SOLUTION

- Roll or level the lawn
- Raise the cutting height
- Slow down
- Correctly level the deck
- Check and inflate the tires

## Stingers

Stingers are sparse patches of uncut grass left behind the mower. Stingers are usually caused by operator error or poor blade maintenance.

## Stingers

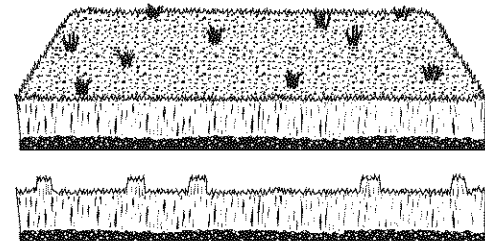

### CAUSE

- Blades are not sharp or are nicked
- Blades are worn down too far
- Engine speed is too slow
- Ground speed is too fast
- Deck is plugged with grass

### SOLUTION

- Sharpen your blades
- Replace your blades
- Always mow at full throttle
- Slow down
- Clean out the mower

# SNAPPER PRODUCT REGISTRATION FORM

IMPORTANT: KEEP THIS INFORMATION FOR YOUR PERSONAL RECORDS  
(Complete the following information on your Snapper purchase)

Model Number \_\_\_\_\_

Serial Number \_\_\_\_\_

Date of Purchase \_\_\_\_\_

Retailer \_\_\_\_\_

Retailer's Phone Number \_\_\_\_\_

It is very important that you register your purchase with Snapper to ensure warranty coverage. Please mail your product registration card to:

Snapper at P.O. Box 777, McDonough, Georgia 30253.

Or you may register on line at [www.snapper.com](http://www.snapper.com).

You can contact us at our web site or if you would like to speak with a Customer Service Representative. Call us at the Snapper Customer Relations Center. For faster service please have your Serial Number and Model Number available.

Call the Snapper Customer Relations Center at 1-800-935-2967.

**Eastern Standard Time**

**Monday through Friday from 8am to 6pm.**

**Saturday from 9am to 1pm.**

# **SNAPPER®**

## **2 YEAR LIMITED WARRANTY**

For two (2) years from purchase date for the original purchaser's use, **SNAPPER**, through any authorized **SNAPPER** dealer will replace, free of charge (except for taxes where applicable), any part or parts found upon examination by the factory at McDonough, Georgia, to be defective in material or workmanship or both.

For ninety (90) days from purchase date for the original purchaser's rental use, **SNAPPER**, through any authorized **SNAPPER** dealer will replace, free of charge (except for taxes where applicable), any part or parts found upon examination by the factory at McDonough, Georgia, to be defective in material or workmanship or both.

All transportation costs incurred by the purchaser in submitting material to an authorized **SNAPPER** dealer for replacement under this warranty must be paid by the purchaser.

This warranty does not apply to transmissions, to engines and their components, and batteries, as these items are warranted separately. This warranty does not apply to parts that have been damaged by accident, alteration, abuse, improper lubrication, normal wear, or other cause beyond the control of **SNAPPER**. This warranty does not cover any machine or component that has been altered or modified, changing safety, performance, or durability.

Batteries have a one (1) year warranty period with free replacement if required for one (1) year from the original purchase date. **SNAPPER** will not be responsible for any installation cost incurred. The battery warranty only covers original equipment batteries and does not cover damage to the battery or machine caused by neglect or abuse, destruction by fire, explosion, freezing, overcharging, improper maintenance, or use of improper electrolyte.

There is no other express warranty.

### **DISCLAIMER OF WARRANTY**

Implied warranties, including those of merchantability and fitness for a particular purpose, are limited to two (2) years from purchase date for the original purchaser's non-rental use, and ninety (90) days from the purchase date for the original purchaser's rental use, and up to the extent permitted by law and all implied warranties are excluded. This is the exclusive remedy. Liabilities for consequential damages, under any and all warranties are excluded.

Some states do not allow limitations on how long an implied warranty lasts, or do not allow the exclusion or limitation of incidental or consequential damages, so the above limitation or exclusion may not apply to you.

This warranty gives you specific legal rights, and you may also have other rights which vary from state to state.

**WARNING: THE USE OF REPLACEMENT PARTS OTHER THAN GENUINE SNAPPER PARTS MAY IMPAIR THE SAFETY OF SNAPPER PRODUCTS AND WILL VOID ANY LIABILITY AND WARRANTY BY SNAPPER ASSOCIATED WITH THE USE OF SUCH PARTS.**

**IMPORTANT:** Please fill out the attached **SNAPPER** Product Registration Card immediately and mail to:  
**Snapper's Product Registration Center, P.O. Box 1379, McDonough, Georgia. 30253**

# ***Safety Instructions & Operator's Manual for***

# ***SNAPPER***®

## ***TRANSAXLE DRIVE WALK-BEHIND MOWER***

### **IMPORTANT**

Snapper products are built using engines that meet or exceed all applicable emissions requirements on the date manufactured. The label on those engines contain very important emissions information and critical safety warnings. Read, Understand, and Follow all warnings and instructions in this manual, the engine manual, and on the machine, engine and attachments. If you have any questions about your Snapper product, contact your local authorized Snapper dealer or contact Snapper Customer Service at Snapper, McDonough, GA. 30253. Phone: (1-800-935-2967).



### **WARNING**

**BATTERY POSTS, TERMINALS AND RELATED ACCESSORIES CONTAIN LEAD AND LEAD COMPOUNDS, CHEMICALS KNOWN TO THE STATE OF CALIFORNIA TO CAUSE CANCER AND BIRTH DEFECTS OR OTHER REPRODUCTIVE HARM. WASH HANDS AFTER HANDLING.**



### **WARNING**

**ENGINE EXHAUST, SOME OF ITS CONSTITUENTS, AND CERTAIN VEHICLE COMPONENTS CONTAIN OR EMIT CHEMICALS KNOWN TO THE STATE OF CALIFORNIA TO CAUSE CANCER OR OTHER REPRODUCTIVE HARM.**