

**SEARS**

**OWNERS  
MANUAL**

**Model No.  
486.244040  
48"  
SNOW BLADE**

**CAUTION:**  
Read Rules for  
Safe Operation  
and Instructions  
Carefully

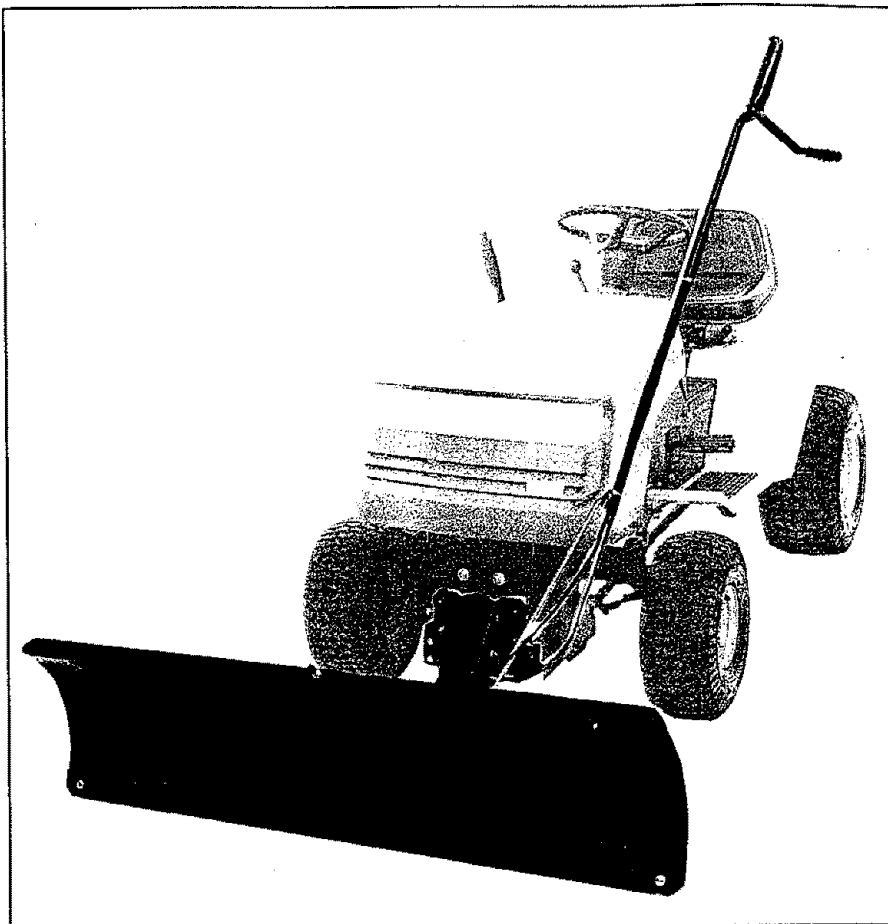

**CRAFTSMAN  
48" SNOW BLADE**

Sears, Roebuck and Co., Hoffman Estates, IL. 60179 U.S.A.

PRINTED IN U.S.A.

# RULES FOR SAFE OPERATION

Any power equipment can cause injury if operated improperly or if the user does not understand how to operate the equipment.



LOOK FOR THIS SYMBOL TO POINT OUT IMPORTANT SAFETY PRECAUTIONS. IT MEANS--ATTENTION! BECOME ALERT! YOUR SAFETY IS INVOLVED.

Exercise caution at all times, when using power equipment.

1. Read the tractor and snow blade owners manuals and know how to operate your tractor before using tractor with snow blade attachment.
2. Never operate tractor and snow blade without wearing proper clothing suited to weather conditions and operation of controls.
3. Never allow children to operate tractor and snow blade, and do not allow adults to operate without proper instructions.
4. Always begin with transmission in first (low) gear and gradually increase speed as required.

**CONGRATULATIONS** on your purchase of a Sears snow blade. It has been designed, manufactured and engineered to give you the best possible dependability and performance.

Should you experience any problem you can not easily remedy, please contact your nearest Sears Service Center/Department. We have competent well trained technicians and the proper tools to service or repair this snow blade.

Please read and retain this manual. The instructions will enable you to assemble and maintain your snow blade properly. Always observe the "SAFETY RULES". †

## MAINTENANCE AGREEMENT

- A Sears maintenance agreement is available on this snow blade. Contact your nearest Sears store for details.

## CUSTOMER RESPONSIBILITIES

- Read and observe the safety rules.
- Follow the instructions under "Customer Responsibilities" and "Storage" sections of this manual.

## TABLE OF CONTENTS

SAFETY RULES.....	2	ASSEMBLY FOR 536... SERIES.....	8-9
CUSTOMER RESPONSIBILITIES.....	2	UNIVERSAL FINAL ASSEMBLY.....	9-12
ACCESSORIES.....	3	OPERATION AND ADJUSTMENTS.....	12-13
CARTON CONTENTS.....	3-4	STORAGE.....	13
ASSEMBLY FOR 917... SERIES.....	4-6	PARTS EXPLOSION.....	14
ASSEMBLY FOR 502... SERIES.....	6-8	REPAIR PARTS.....	15
		PARTS ORDERING/SERVICE.....	BACK COVER

# ACCESSORIES

These accessories were available when your snow blade was purchased. They are also available at most Sears retail outlets and service centers. Most Sears stores can also order repair parts for you when you provide the model number of your snow blade.

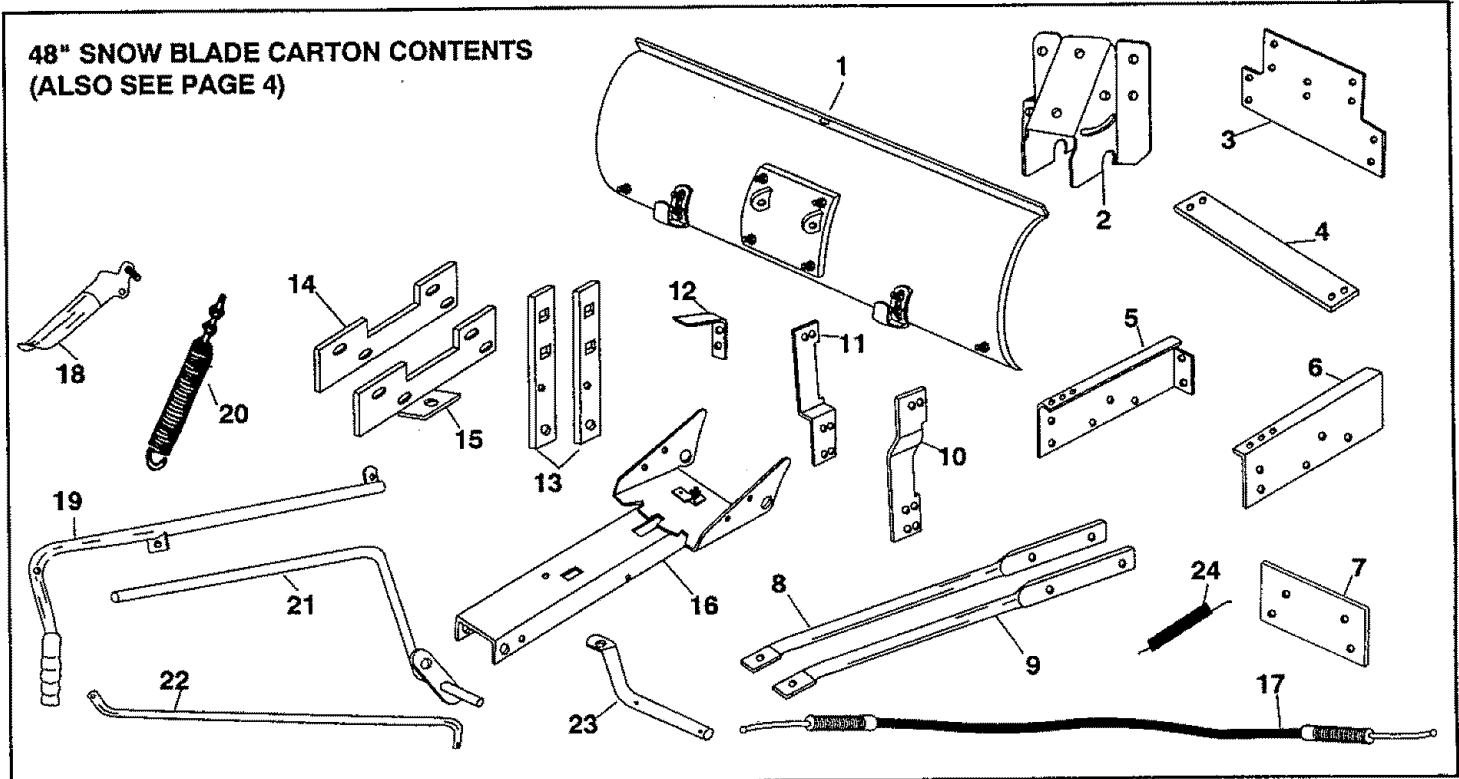
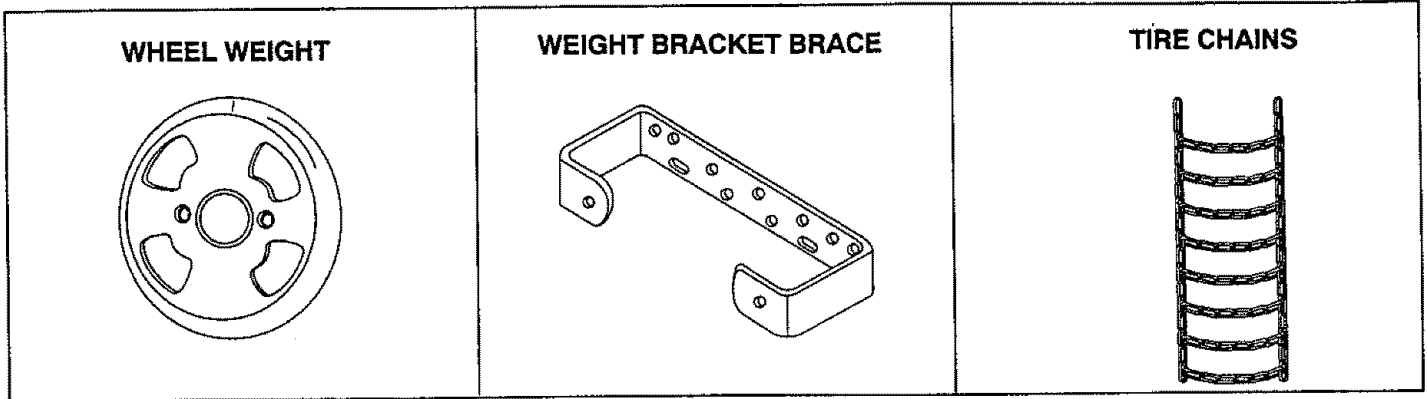

## CARTON CONTENTS

REF. NO.	QTY.	DESCRIPTION	REF. NO.	QTY.	DESCRIPTION
1	1	Blade Assembly	13	2	Angle Lock Bars
2	1	Pivot Support Bracket	14	1	Brace Mount Bracket (L.H.)
3	1	Pivot Support Plate	15	1	Brace Mount Bracket (R.H.)
4	1	Cross Brace	16	1	Channel Assembly
5	1	Frame Pivot Support (L.H.)	17	1	Cable
6	1	Frame Pivot Support (R.H.)	18	1	Grip Assembly
7	1	Pivot Plate Bracket	19	1	Handle Tube
8	1	Brace Tube (L.H.)	20	1	Blade Adjust Spring
9	1	Brace Tube (R.H.)	21	1	Lift Rod
10	1	Brace Bracket (R.H.)	22	1	Blade Pivot Rod
11	1	Brace Bracket (L.H.)	23	1	Pivot Shaft
12	1	Axle Pivot Bracket	24	1	Extension Spring

**NOTE:** Not all of carton contents or parts bag (Figure 1) will be used for one particular fit up.

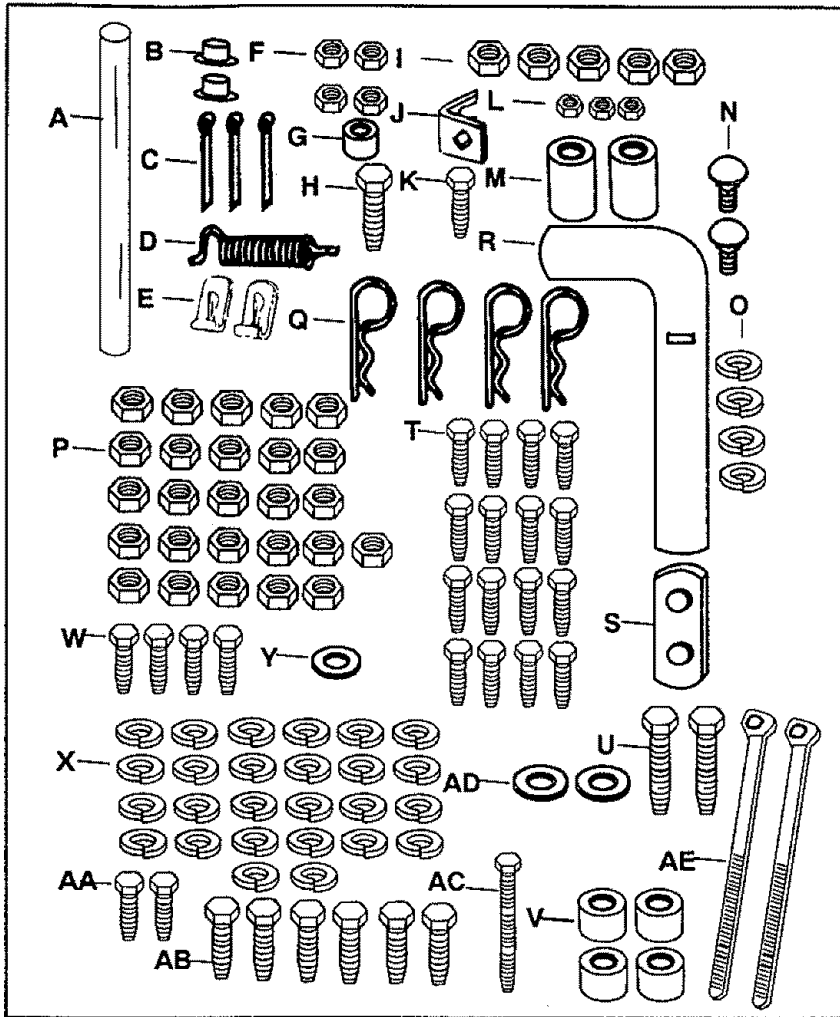

REF.	QTY.	DESCRIPTION
A	1	Spring Mount Rod
B	2	Palnut, 3/8"
C	3	Cotter Pin 1/8" x 1-1/4"
D	1	Angle Lock Spring
E	2	Cable End Fitting
F	4	Hex Jam Nut 5/16" Thread
G	1	Spacer, 9/16" OD x 5/8"
H	1	Hex Bolt, 5/16-18 x 1-1/2"
I	5	Hex Lock Nut 5/16-18 Thread
J	1	Cable Mount Bracket
K	1	Hex Bolt 1/4-20 x 1-1/4"
L	3	Hex Lock Nut 1/4-20 Thread
M	2	Spacer, 9/16" OD x 1" LG.
N	2	Carriage Bolt 3/8-16 x 1-1/4"
O	4	Lock Washer 5/16"
P	26	Hex Lock Nut 3/8-16 Thread
Q	4	Hairpin Cotter
R	1	Pivot channel shaft
S	1	Lift Link Ass'y
T	18	Hex Bolt 3/8-16 x 1"
U	2	Hex Bolt 3/8-16 x 2"
V	4	Spacer, 1" OD x .60 LG.
W	4	Hex Bolt, 5/16-18 x 3/4" LG.
X	26	Washer, 3/8" Lock
Y	1	Washer 1/2"
AA	2	Hex Bolt, 3/8-16 x 1-1/4" LG.
AB	6	Hex Bolt, 3/8-16 x 3/4" LG.
AC	1	Hex Bolt, 1/4-20 x 3-1/4" LG.
AD	2	Washer, 3/8" STD.
AE	2	Nylon Tie

FIGURE 1

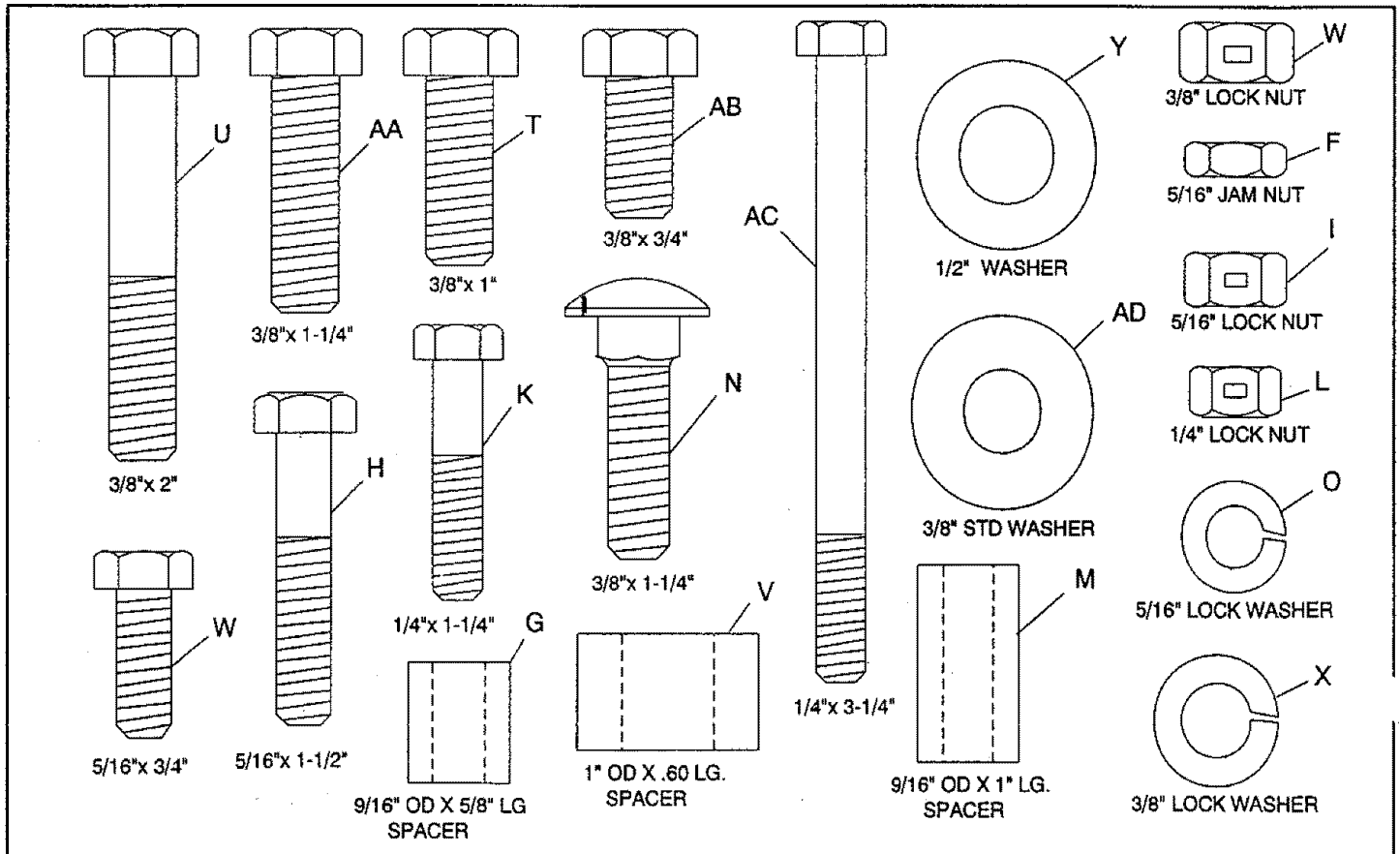

FULL SIZE HARDWARE REFERENCE CHART

# ASSEMBLY INSTRUCTIONS

## TOOLS REQUIRED FOR ASSEMBLY

- (1) Pliers
- (1) Hammer
- (1) Adjustable Wrench (or socket set)
- (1) 9/16" Open End or Box Wrench
- (1) 7/16" Open End or Box Wrench
- (1) 1/2" Open End or Box Wrench

## REMOVAL OF PARTS FROM CARTON

- Refer to carton contents figure on page 3 and figure 1 on page 4 for parts and hardware needed to assemble snow blade.

**NOTE:** Right hand (R.H.) and left hand (L.H.) are determined from operators position while seated in the tractor.

## TRACTOR PREPARATION

- Remove mower deck or any other attachment you may have mounted to your tractor. Mark all loose parts and save for re-assembly. Refer to owners manual for removal of mower/attachment.

## ASSEMBLY OF SNOW BLADE TO SERIES 917... TRACTORS

FOR ASSEMBLY OF SNOW BLADE TO SERIES 502... TRACTORS GO DIRECTLY TO PAGE 6

FOR ASSEMBLY OF SNOW BLADE TO SERIES 536... TRACTORS GO DIRECTLY TO PAGE 8

- Assemble frame pivot supports (R.H. and L.H.) to pivot support plate using four 3/8" x 1" hex bolts, lock washers and locknuts. See figure 2.
- Using the inside two holes of the frame pivot supports, attach the cross brace using four 3/8" x 3/4" hex bolts, lock washers and lock nuts. See figure 2.

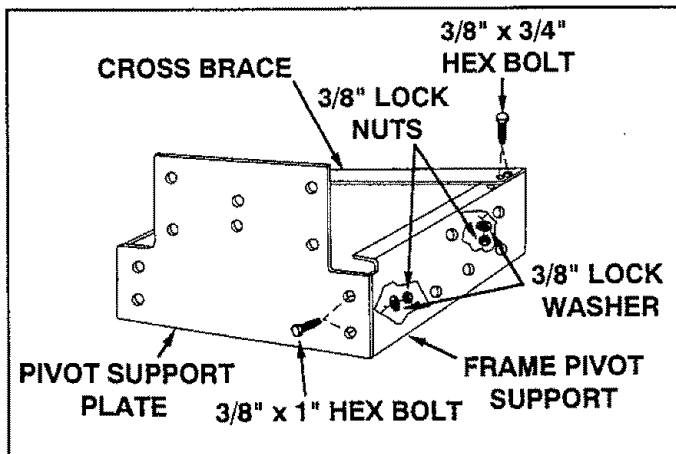

FIGURE 2

- Place the lift link inside the pivot support bracket. The long pin on the lift link goes through the slot in the pivot support bracket. The short pin goes through the hole shown in figure 3. Secure short pin with 1/8" x 1-1/4" cotter pin.

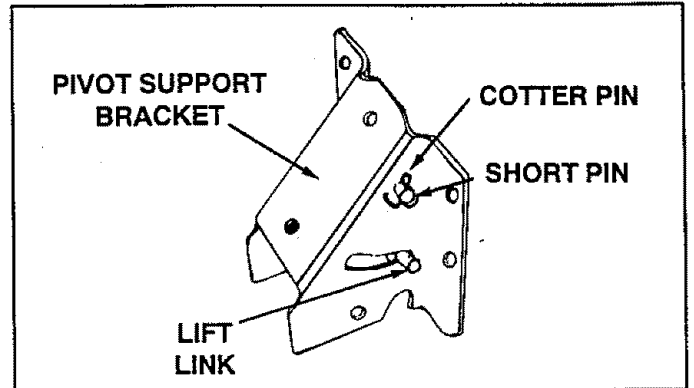

FIGURE 3

- Using the bottom hole on each side, attach the pivot support bracket to outside of plate pivot support using two 3/8" x 1" hex bolts, lock washers and lock nuts. See figure 4.
- Using the top hole on each side, assemble the pivot plate bracket to the inside of the plate pivot support using two 3/8" x 1-1/4" hex bolts, lock washers and lock nuts. See figure 4.
- Attach the left and right hand tube braces to the left and right hand frame pivot supports using four 3/8" x 1" hex bolts, lock washers and lock nuts. **Do not tighten at this time.** See figure 4.

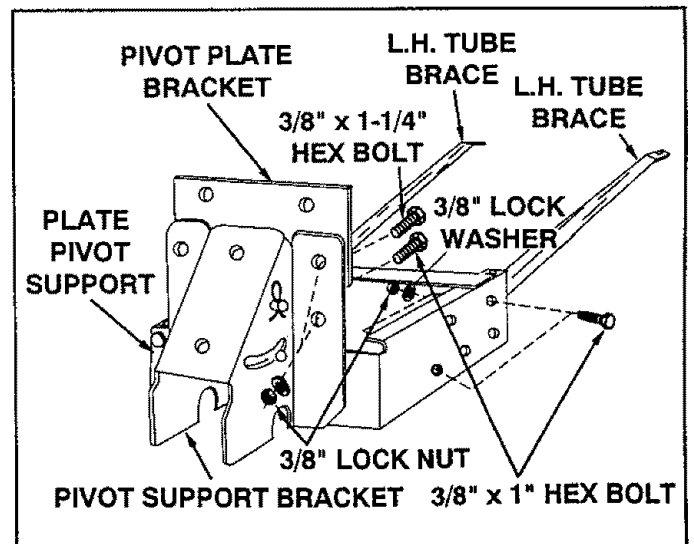

FIGURE 4

- Lower the mower lift assembly.
- Starting at the rear of the foot rest, remove and discard the bolts that are currently in the bottom set of holes pointed out in figure 5.
- Place a 3/8" x 3/4" hex bolt in ear of each brace mount bracket as shown in figure 5. Now using the bottom two holes attach each brace mount bracket (R.H and L.H.) to the underneath side of the tractor frame using four 3/8" x 1" hex bolts, lock washers and lock nuts. (Brackets should be positioned inside of frame with ears sticking outward.) See figure 5.

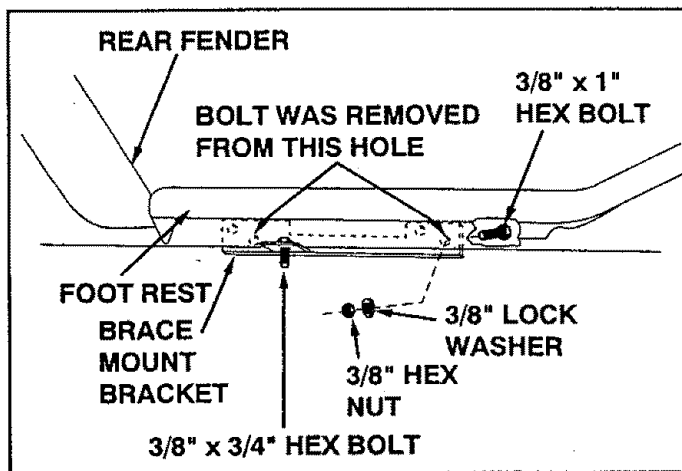

FIGURE 5 (Right hand side view)

- Raise the mower lift assembly.
- Slide blade frame assembly under tractor, with the brace tubes at the rear.
- Attach brace tube to brace mount bracket using the 3/8" x 3/4" hex bolt already put in place during step 6. Secure with a 3/8" lock washer and 3/8" lock nut. **Do not tighten at this time.** Repeat this step on opposite side. See figure 6.

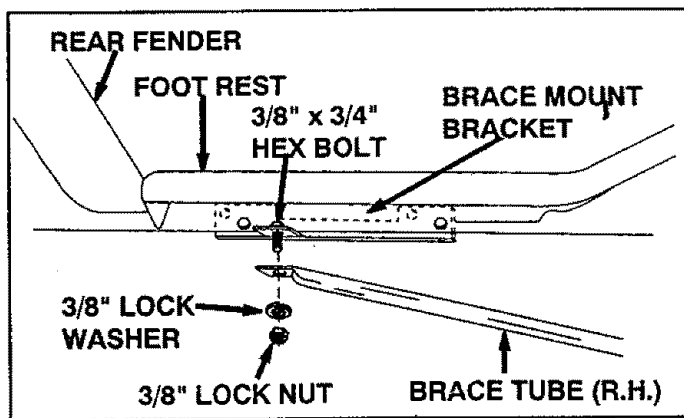

FIGURE 6

- Attach blade frame assembly to tractor frame by aligning holes in tractor frame to those in the pivot plate bracket. Secure using two 3/8" x 1" hex bolts, 3/8" flat washers, 3/8" lock washers and 3/8" lock nuts. **Tighten all items previously left untightened.** See figure 7.

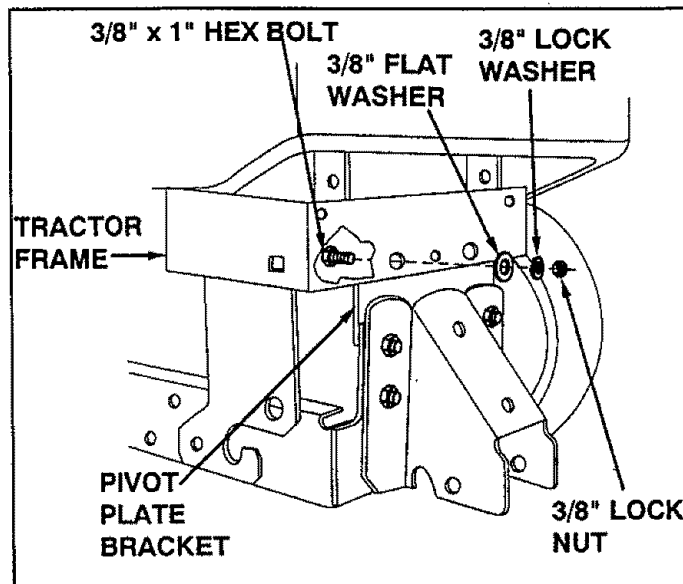

FIGURE 7

- See FINAL ASSEMBLY on page 9 to complete your hook up.

## ASSEMBLY OF SNOW BLADE TO SERIES 502... TRACTORS

- Assemble frame pivot supports (R.H. and L.H.) to plate pivot support using four 3/8" x 1" hex bolts, lock washers and locknuts. See figure 8.
- Using the back two holes of the frame pivot supports, attach the cross brace using four 3/8" x 3/4" hex bolts, lock washers and lock nuts. See figure 8.
- Assemble axle pivot bracket to pivot support plate using two 3/8" x 1" hex bolts, 3/8" lock washers and 3/8" lock nuts. See figure 8.

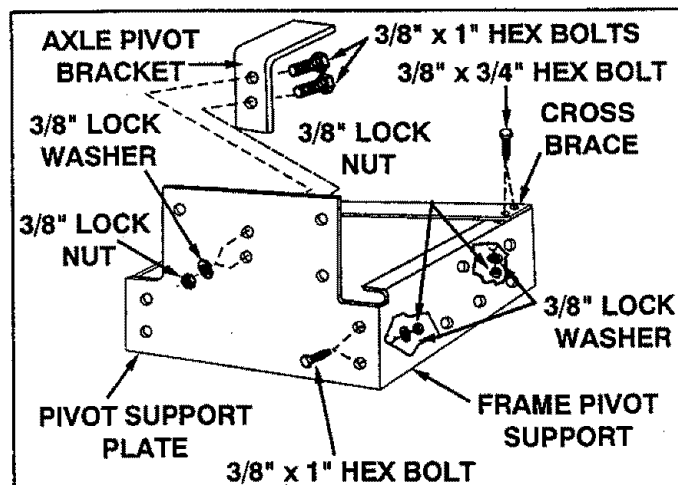
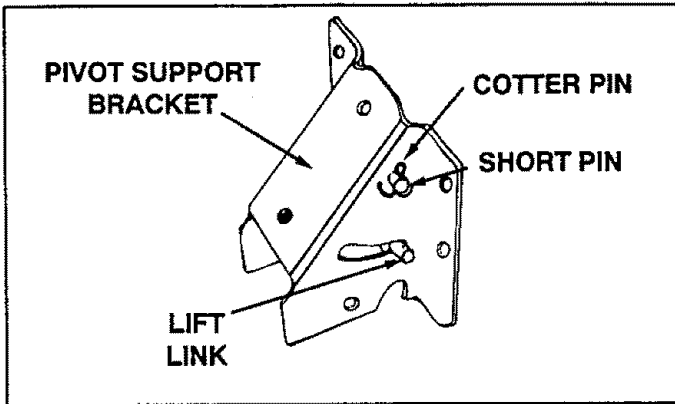

FIGURE 8

- Place the lift link inside the pivot support bracket. The long pin on the lift link goes through the slot in the pivot support bracket. The short pin goes through the hole shown in figure 9. Secure short pin with 1/8" x 1-1/4" cotter pin.



**FIGURE 9**

- Using the two holes on each side of the pivot support bracket, attach it to the outside of the plate pivot support using four 3/8" x 1" hex bolts, lock washers and lock nuts. See figure 10.

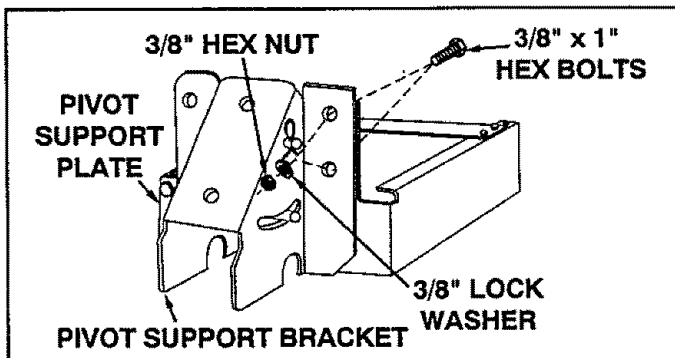

**FIGURE 10**

- Attach brace brackets (R.H. and L.H.) to the tractor frame using the appropriate hole as shown in figure 11. Secure each bracket with one 3/8" x 1" hex bolt, lock washer and locknut. See figure 11.

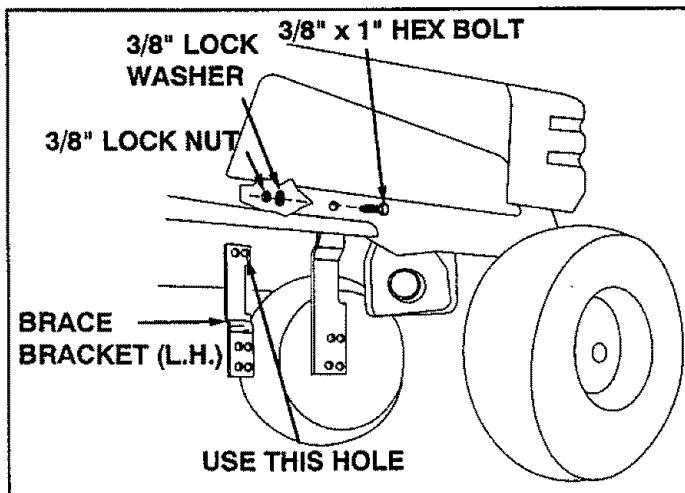

**FIGURE 11**

- Attach blade frame assembly to the tractor frame by inserting the axle pivot bracket into the hole in the center of the axle. See figure 12.
- Attach brace brackets (R.H. and L.H.) to the blade frame ass'y using a 3/8" x 1" hex bolt, 3/8" lock washer and 3/8" lock nut. Use the appropriate holes shown below. See figure 12. Repeat this step on opposite side.

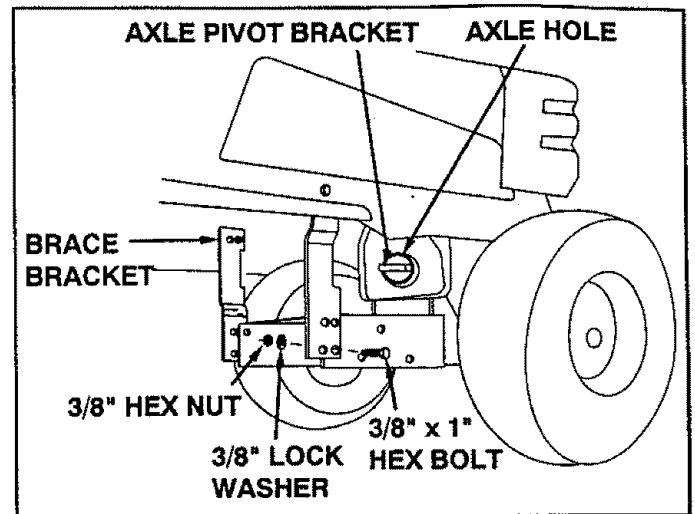

**FIGURE 12**

- Place a 3/8" x 3/4" hex bolt in ear of each brace mount bracket as shown in figure 13. Remove and discard the bolts that are in the holes called out in figure 13. Now attach each brace mount bracket to the tractor frame using four 5/16" x 3/4" hex bolts, lock washers and lock nuts. Brace mount brackets go on the inside of the tractor frame as shown in figure 13.

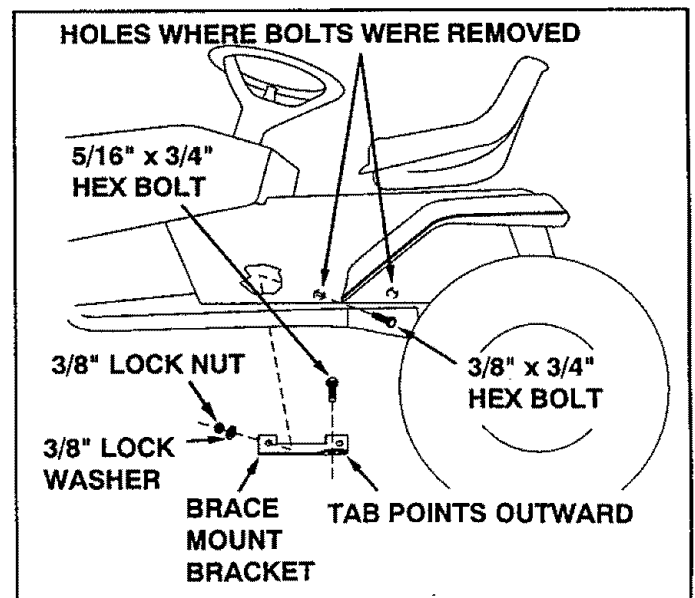

**FIGURE 13**

- Attach the brace tubes (L.H. and R.H.) to the outside of the blade frame ass'y using two 3/8" x 1" hex bolts, lock washers and lock nuts on each side. See figure 14. Attach the other end to the brace mount bracket (assembled in step 7) using the holes shown in figure 14. Secure with a 3/8" x 3/4" hex bolt, lock washer, and lock nut on each side.

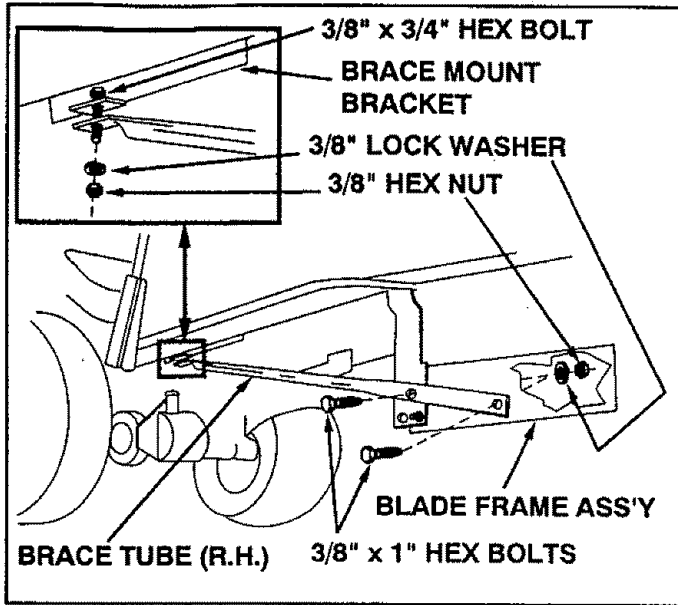

FIGURE 14

- See FINAL ASSEMBLY on page 9 to complete your hook up.

## ASSEMBLY OF SNOW BLADE TO SERIES 536... TRACTORS

- Assemble frame pivot supports (R.H. and L.H.) to pivot support plate using four 3/8" x 1" hex bolts, lock washers and locknuts. See figure 15.
- Using the rear two holes on the frame pivot supports, attach the cross brace using four 3/8" x 3/4" hex bolts, lock washers and lock nuts. See figure 15.

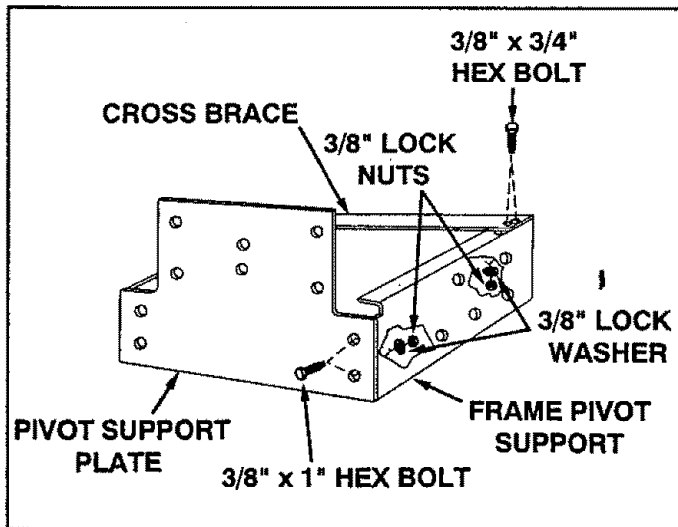

FIGURE 15

- Place the lift link inside the pivot support bracket. The long pin on the lift link goes through the slot in the pivot support bracket. The short pin goes through the hole shown in figure 16. Secure short pin with 1/8" x 1-1/4" cotter pin.

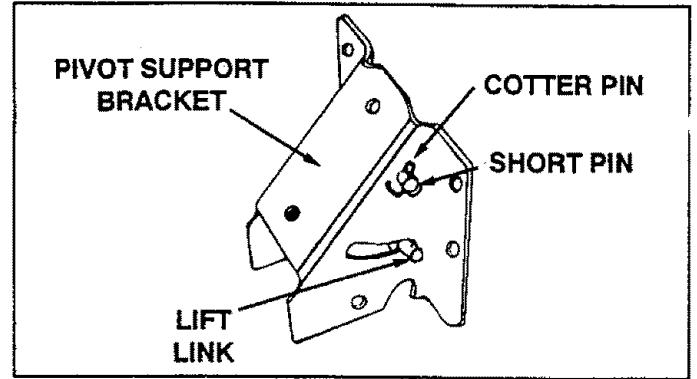

FIGURE 16

- Using the two holes on each side of the pivot support bracket, attach it to the outside of the plate pivot support using four 3/8" x 1" hex bolts, lock washers and lock nuts. See figure 17.
- Paying special attention to which way the curves are running, Attach the brace brackets to each side of the frame using the bottom inside hole on each side as shown in figure 17. Secure each using two 3/8" x 1" hex bolts, lock washers and lock nuts. See figure 17.

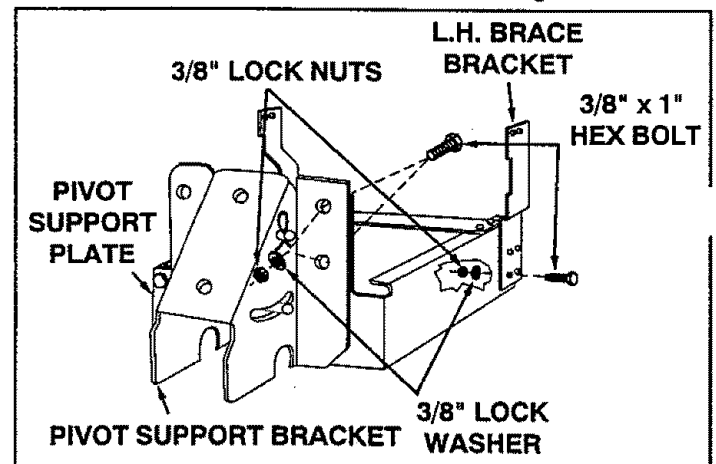

FIGURE 17

- Attach one brace tube to each side of blade frame assembly using two 3/8" x 1" hex bolts, lock washers and lock nuts. Each brace tube should be slightly angled outward. See figure 18.

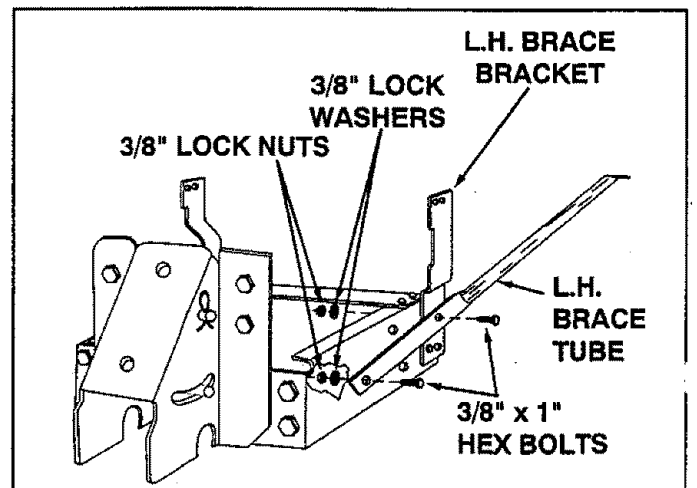

FIGURE 18



- Attach brace tube to tractor frame using a 3/8" x 2" hex bolt, two spacers, lock washer and lock nut. Use the hole located to the inside back of the foot rest. Hole is concealed by rubber padding. **Do not tighten at this time.** Repeat this step on opposite side. See figure 19.

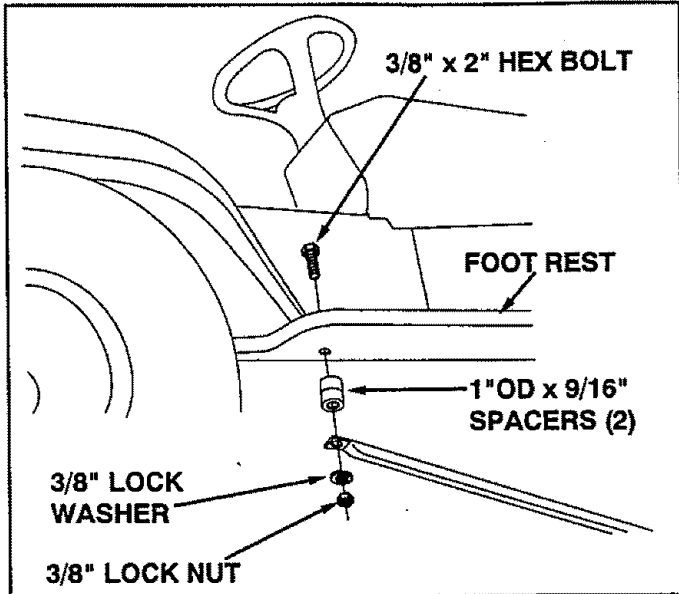

FIGURE 19

- Remove the 7/16" x 1" bolt from the tractor frame located just after the foot rest and below the engine on each side panel, if there is one. The empty hole is shown in figure 20. Attach brace brackets (R.H. and L.H.) to the tractor frame using a 3/8" x 1" hex bolt, 3/8" lock washer and 3/8" lock nut on each side. See figure 20. **Tighten all loose nuts assembled in figure 19.**

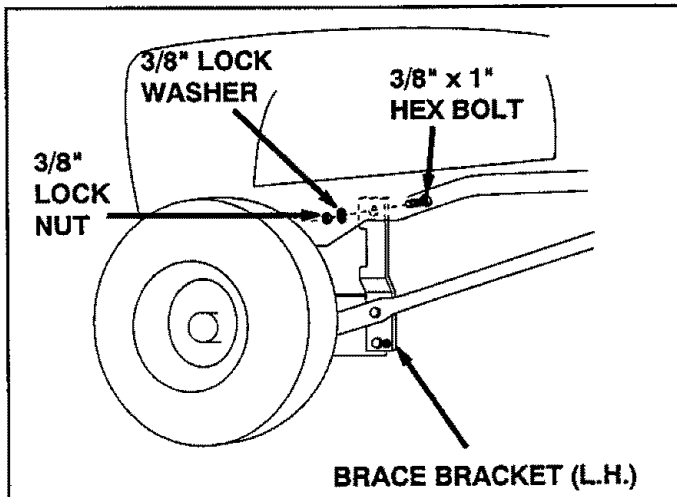

FIGURE 20

## FINAL ASSEMBLY

- Assemble the two angle lock bars together as shown in figure 21, using one 3/8" x 1-1/4" carriage bolt, one 3/8" lock washer and one 3/8" hex nut. See figure 18. **Do not tighten at this time.**

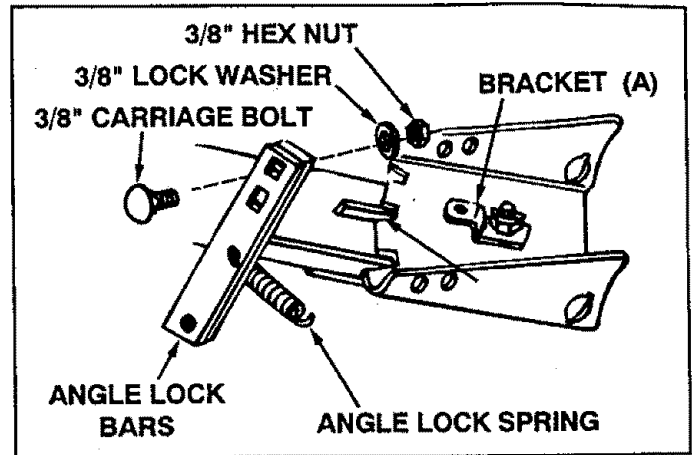

FIGURE 21

- Assemble angle lock spring through angle lock bars positioning end hook as shown. See figures 21 and 22.
- Assemble hook of angle lock spring into hole of bracket (A). Pull lock bars up to extend spring just enough to allow assembly of angle lock bars down through slot in pivot bracket and channel. See figures 21 and 22.
- Assemble one 1/4" x 3-1/4" hex bolt, two .28 ID x 1" long spacers through slot in bracket and hole in end of lock bars and secure with one 1/4" lock nut. One spacer should go on each side of the angle lock bars, with the hex nut securing on the outside of the channel. See figure 22. **Tighten 3/8" hex nut left loose in first step of final assembly.**

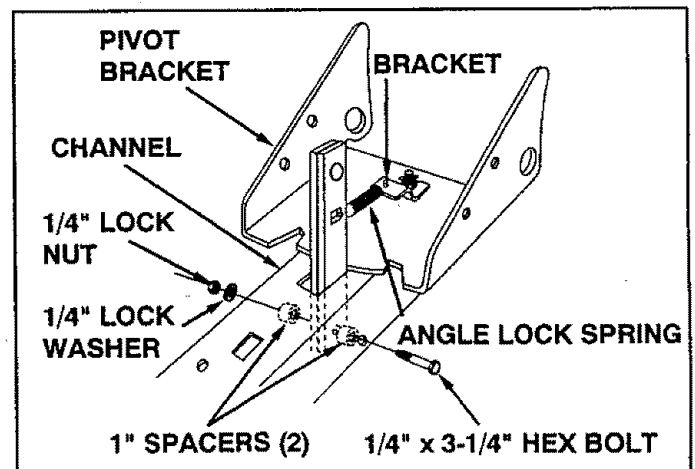
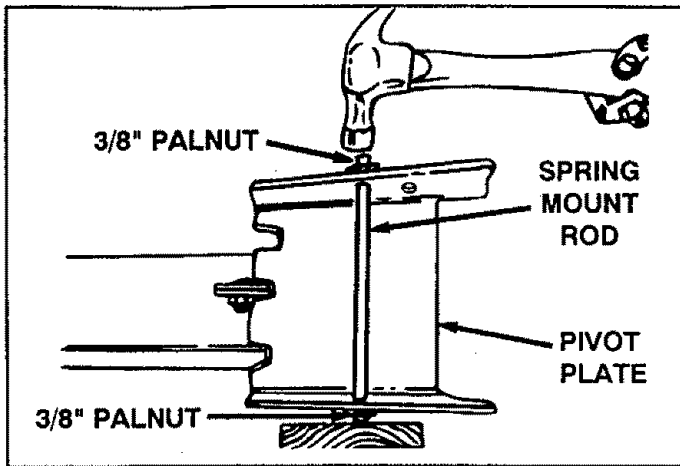

FIGURE 22

**NOTE:** Lock bars should pivot freely; and when pulled all the way back, the channel/pivot plate assembly should be unlocked and free to pivot to right or left position notches.

- Using a hammer drive a 3/8" palnut onto one end of spring mount rod. Insert the other end of the spring mount rod through the back hole on each side of the pivot plate. Support end (with palnut) of the spring mount rod with a block of wood, and hammer on the remaining palnut. See figure 23.



**FIGURE 23**

- Assemble 3/8" x 1-1/4" carriage bolt through square hole in cable mount bracket and through square hole in lock bars. See figures 24 and 25. Hold cable mount bracket in position as shown in figure 24 and secure with 3/8" lock washer and 3/8" lock nut.

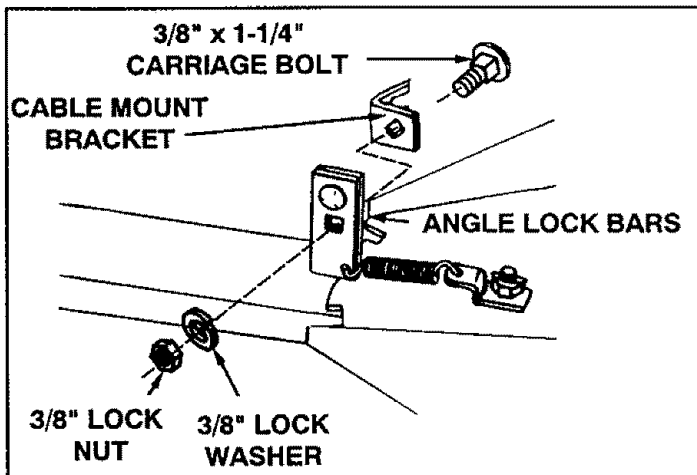

**FIGURE 24**

- Assemble one 5/16-24 jam nut onto threaded end of control cable approximately 3/4" from end. Assemble threaded cable end through round hole in cable mount bracket and secure with another 5/16-24 jam nut. See figure 25.

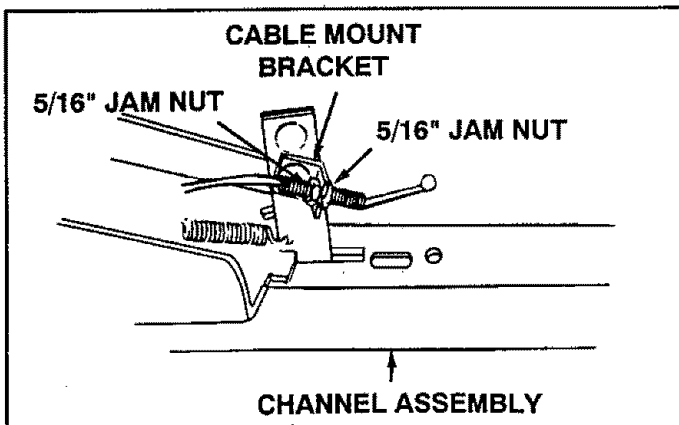

**FIGURE 25**

- Assemble ball end of cable through round hole in cable end fitting and into slot of fitting. See figures 25 and 26.
- Assemble 1/4" x 1-1/4" hex bolt down through cable end fitting, long spacer, and through hole in channel Assembly. Secure with 1/4" hex lock nut. See figure 26.

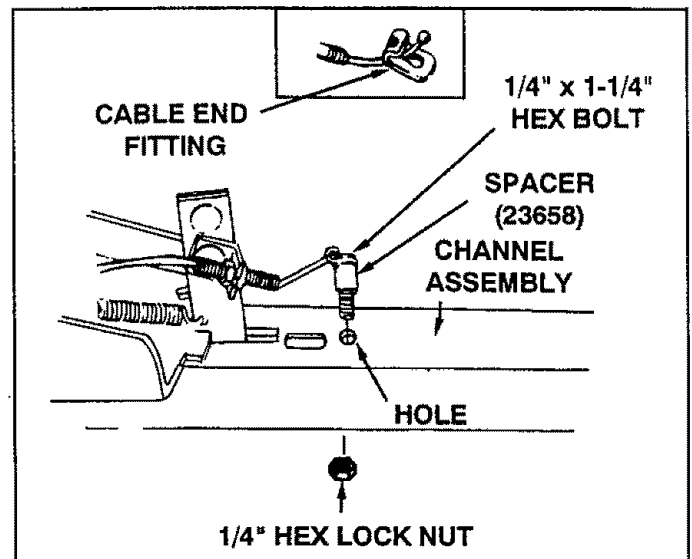

**FIGURE 26**

- Assemble one 5/16" jam nut onto threaded end of control cable approximately 3/4" from end. Assemble threaded end of cable up through cable mount ear on handle assembly and secure with a second 5/16" jam nut. See figure 27.

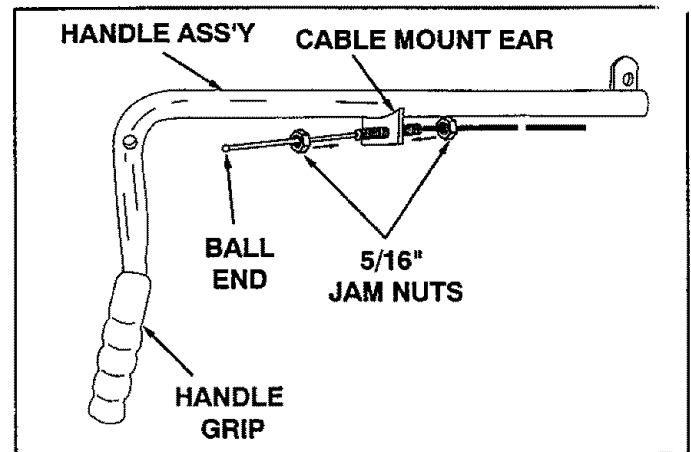

**FIGURE 27**

- Assemble grip assembly to handle assembly using one 5/16" x 1-1/2" hex bolt and one 5/16" hex lock nut. See figure 28.

**NOTE:** Do not over tighten lock nut, grip assembly must pivot freely.

- Assemble ball end of cable through round hole in cable end fitting and into slot of fitting. (as was done in figure 26). Secure cable end fitting to handle assembly with 1/4" hex lock nut. See figure 28.

**NOTE:** Do not over tighten lock nut, cable fitting must pivot freely.

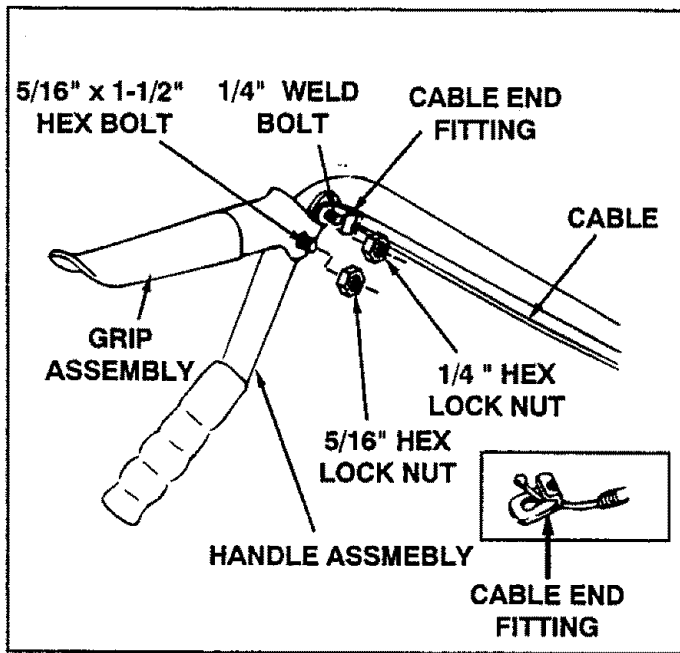

FIGURE 28

- Attach blade assembly to channel assembly using the pivot shaft. Secure with two 1/8" x 1-1/4" cotter pins. See figure 29.
- Attach blade adjust spring over spring mount rod as shown in figure 29. Remove plastic cap, and 3/8" hex nut. Adjust the remaining 3/8" hex nut on the long bolt to approximately one inch down from end of bolt threads. Assemble adjusting bolt through hole in top edge of blade and hold in place with 3/8" hex nut removed earlier. Tighten 3/8" hex nut on top edge of blade down against the bottom 3/8" hex nut. Replace plastic cap over end of adjusting bolt threads. See figure 29.

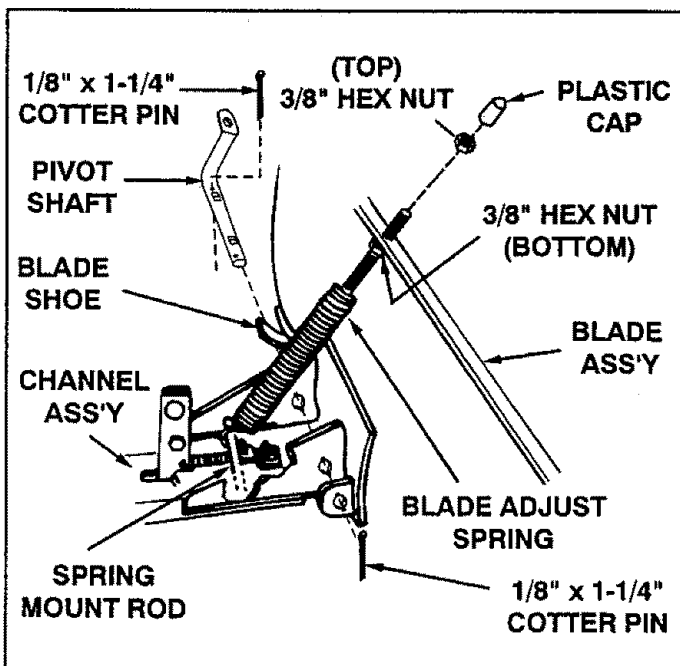

FIGURE 29

- Place the end of the channel assembly into pivot support bracket. Secure with pivot pin, 1/2" washer and one hairpin cotter. See figure 30.

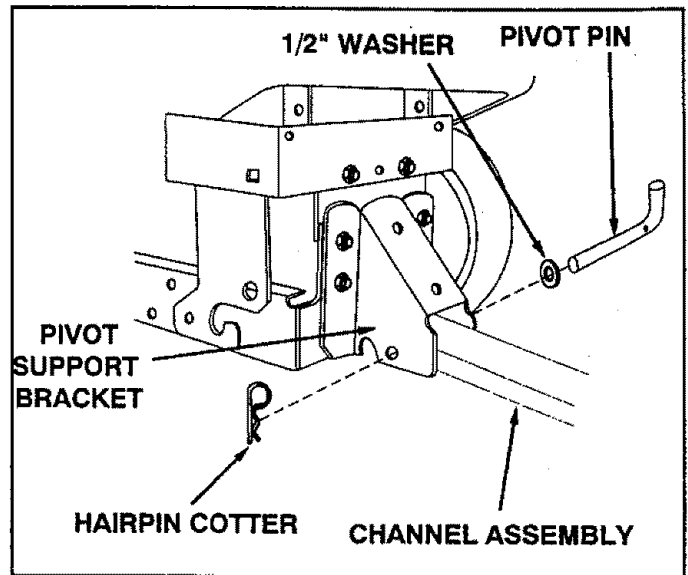

FIGURE 30

- Insert the lift rod inside the lift handle tube as shown in figure 31. Insert the other end of the lift rod in the bottom hole in the pivot support bracket and channel assembly. The hole in the link, which is welded onto the lift rod, goes over the long pin on the lift link. Secure with a hairpin cotter, which is to be put in from the bottom side of the long pin and pushed through all the way to the circle end. See figure 31.

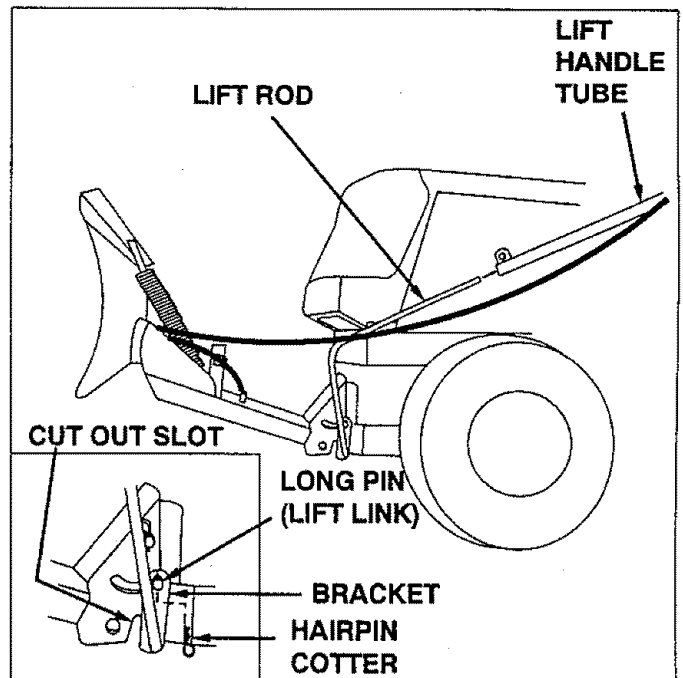

FIGURE 31

- Raise the blade to the transport position.
- Attach the extension spring to the channel and to the pivot support bracket as shown in figure 32.
- Attach short end of the blade pivot rod to the lift handle tube and the long end to the pivot rod. Secure both ends with a hairpin cotter. See figure 32.
- Use the two plastic ties to hold the cable securely to the outside of the handle tube and away from the tractor to avoid direct heat from the tractor muffler. See figure 32.

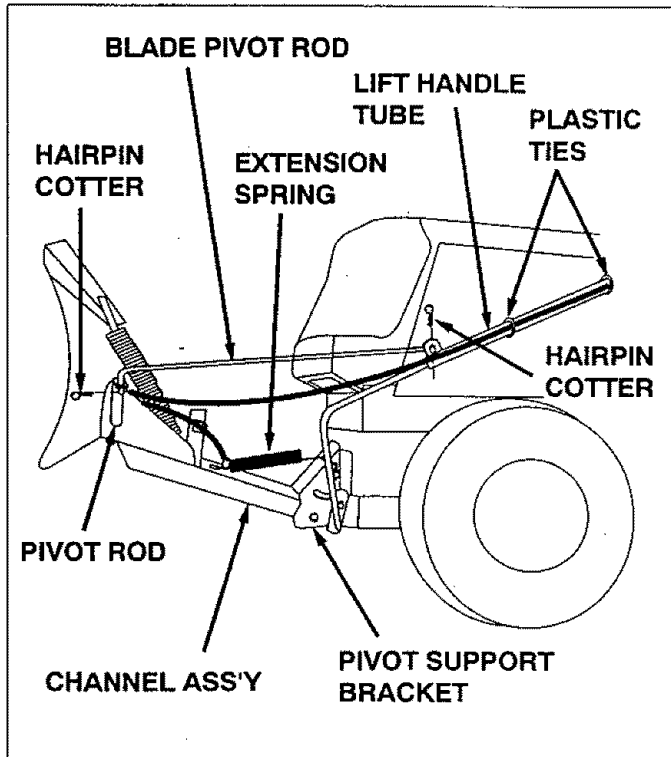

FIGURE 32

## OPERATION INSTRUCTIONS AND ADJUSTMENTS

- **Snow Blade Handle Tube (Lift and Lower)**  
Located on the left hand side of the tractor. See figure 33. Pull down on handle tube to lift snow blade. **Lift up and pull back slightly** on control tube to lower snow blade.
- **Grip Assembly**  
Located on the top of the snow blade control tube. Raise blade to transport position. Squeeze (and hold) grip assembly and push handle tube forward to pivot blade to the right or pull back to pivot blade to the left. Release the grip assembly when blade is in desired position. See figure 33.
- **Blade Shoe Adjustment**  
Blade shoes on ends of blade, (see figure 33), may be raised for close work on smooth surfaces or lowered to raise the blade to work on rough or uneven areas. Make sure both shoes are set evenly and nuts are tightened securely.
- **Lubrication Points**  
Lubricate points shown in figure 33 for easier operation.

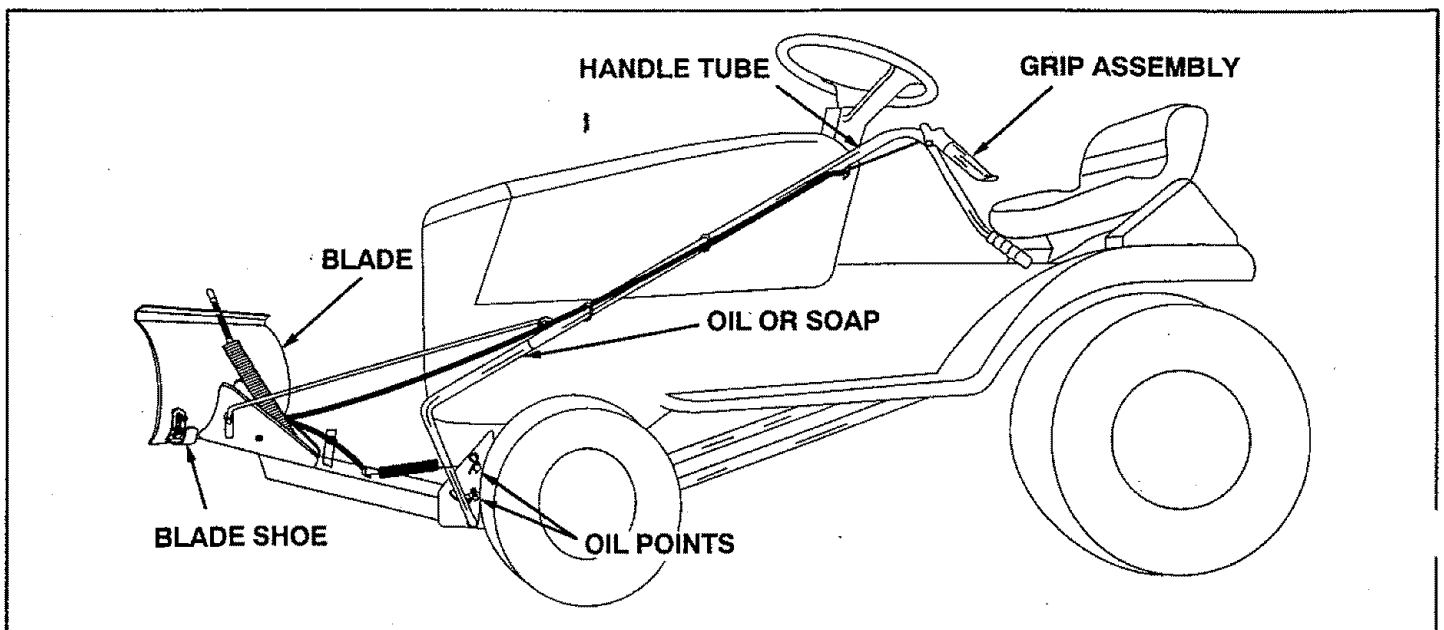

FIGURE 33

## ADJUSTMENTS

### ● Blade Angle Lock Bars

If angle lock bars do not completely disengage from slots in pivot plate assembly, adjustment of cable is required. See figure 34.

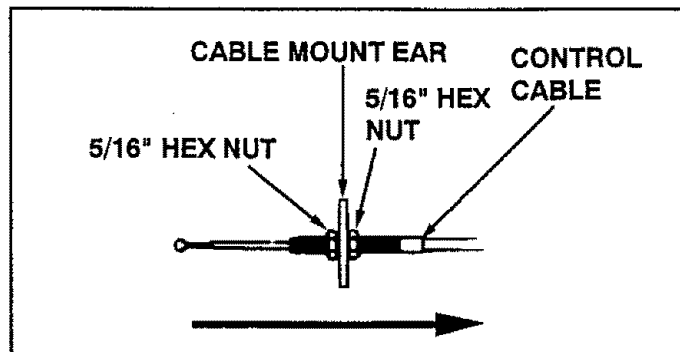

FIGURE 34

### ● Adjust Blade Spring

Blade adjust spring tension is adjustable to permit blade to tilt forward to by-pass solid obstructions. To change spring tension (stand in front of blade assembly), adjust the nuts at the upper end of the spring, turning counter clockwise to relieve tension and clock wise to increase tension. See figure 29 on page 11.



**KNOW THE TERRAIN. AVOID EXCEPTIONALLY SHARP SLOPES OR DROP OFFS WHICH MAY BE HIDDEN BY THE SNOW. NEVER RUN THE SNOW BLADE INTO HEAVY MATERIAL AT HIGH SPEED.**

**NOTE:** Wheel weights and tire chains must be used with your snow blade for traction. These accessories are available at your nearest Sears retail store.

## OPERATION



**INSPECT THE AREA TO BE WORKED CAREFULLY BEFORE OPERATING THE SNOW BLADE. AVOID PIPES, ROOTS, CURBS OR OTHER HEAVY OBSTRUCTIONS.**

- Prepare lawn tractor engine for cold weather using instructions furnished with the lawn tractor.
- Always begin with transmission in first (low) gear and gradually increase speed as required.
- DO NOT push snow in the same direction causing excessive build up with each successive pass.
- If blade is stored in heated area, allow lawn tractor and blade to adjust to outdoor temperature before operating to reduce icing on the metal surfaces.

**NOTE:** When working under the hood while snow blade is attached, the hood may not stay up on its own; therefore, you may need to lay something (such as a piece of wood) over the engine housing to keep the hood propped up.



**ALWAYS LOWER BLADE TO GROUND BEFORE LEAVING TRACTOR.**

## TO REMOVE SNOW BLADE FROM TRACTOR

- Lower blade to ground with blade in the center (straight) position.
- Refer to figure 32.
  - A. Remove 3/32" hairpin cotter from lower end of blade pivot rod.
  - B. Remove 3/32" hairpin cotter from welded link on lift rod and remove control tube assembly.
  - C. Remove 3/32" hairpin cotter from pivot pin and remove pivot pin.

---

## CUSTOMER RESPONSIBILITIES

---

During the operating season, check all bolts, nuts and hairpin cotters to be sure they are secure. For improved snow removal performance, coat the blade with automotive type paste wax.

---

## STORAGE

---

When the snow blade is not being used, remove all dirt and rust and touch up with paint.

Apply a light coat of grease or rust preventive to the blade and oil all pivot points.

Store in an area where it is protected from weather.

# REPAIR PARTS FOR MODEL 486.24404 - 48" SNOW BLADE

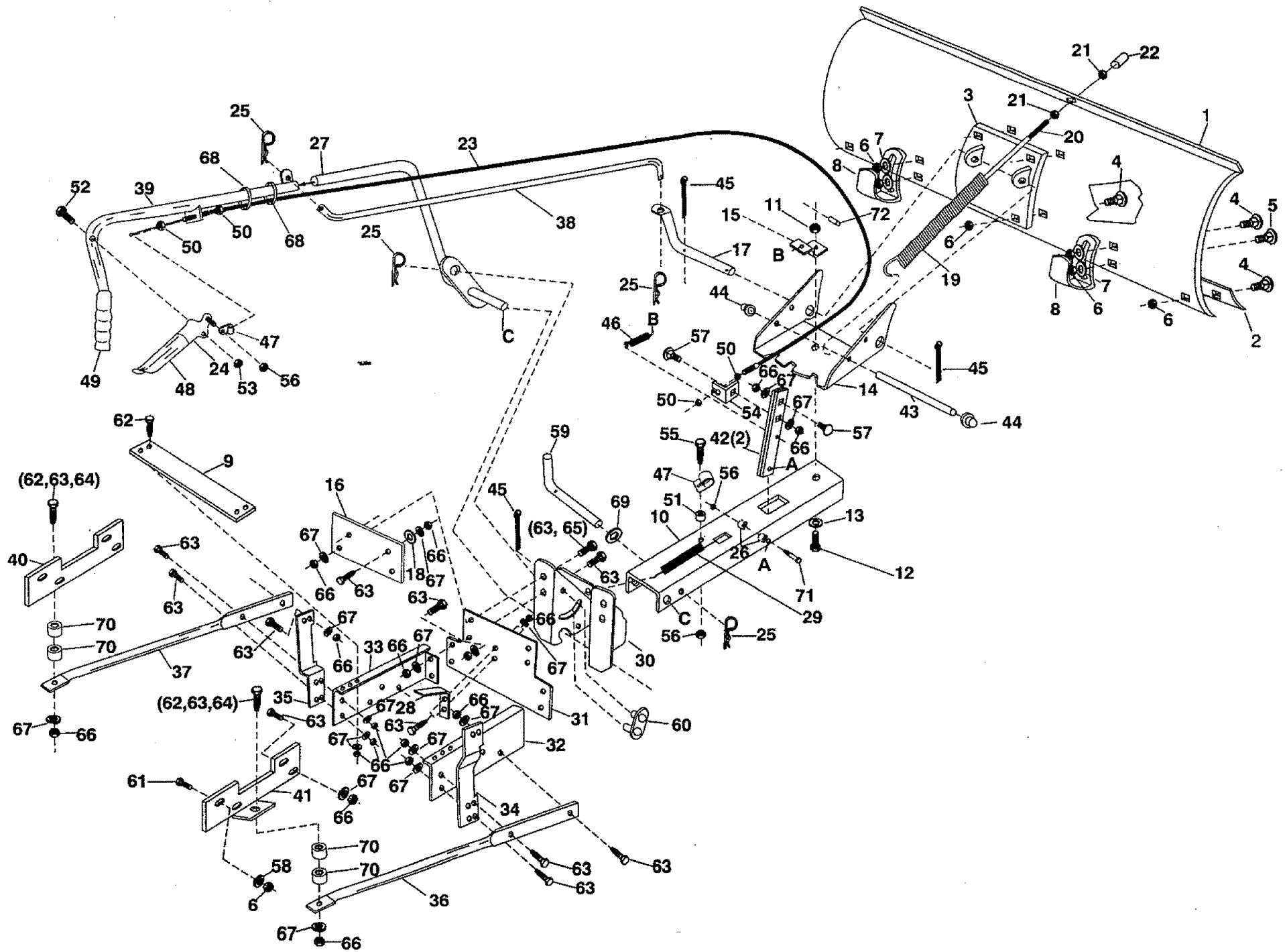

# REPAIR PARTS LIST FOR MODEL 486.24404 - 48" SNOW BLADE

REF. NO.	PART NO.	QTY.	DESCRIPTION	REF. NO.	PART NO.	QTY.	DESCRIPTION
1	23955	1	Blade 48"	38	46049	1	Rod, Blade Pivot
2	23956	1	Wear Plate 48"	39	62972	1	Ass'y Lift Handle Tube
3	62980	1	Reinforcement Plate Ass'y	40	23967	1	Bracket, Brace Mount (rear) (LH)
4	43080	10	Bolt, Carriage 5/16-18 x 3/4"	41	23968	1	Bracket, Brace Mount (rear) (RH)
5	43079	2	Bolt, Carriage 5/16-18 x 1"	42	23151	2	Angle Lock Bar
6	43064	12	Nut, Hex Lock 5/16-18	43	23856	1	Spring Mount Rod
7	43081	4	Washer, 5/16"	44	44917	2	Palnut, 3/8"
8	23070	2	Skid Shoe	45	43010	3	Cotter Pin 1/8" x 1-1/4"
9	23970	1	Brace, Cross	46	43348	1	Angle Lock Spring
10	23957	1	Push Channel	47	746-0260	2	Cable End Fitting
11	43262	1	Nut, Hex Lock 1/2-13	48	731-0869	1	Grip, Plastic
12	23131	1	Bolt, Special Pivot	49	7071	1	Handle, Grip 3/4"
13	43352	1	Washer, Flat 7/16"	50	712-0256	4	Hex Jam Nut 5/16 Thread
14	23958	1	Plate, Pivot 7 Ga.	51	23658	1	Spacer
15	23130	1	Bracket, Spring Mt.	52	43085	1	Hex Bolt, 5/16-18 x 1-1/2"
16	23966	1	Bracket, Pivot Plate	53	43064	5	Hex Lock Nut 5/16-18 Thread
17	46066	1	Shaft Pivot	54	05762	1	Cable Mount Bracket
18	43070	2	Washer 3/8" STD.	55	1509-90	1	Hex Bolt 1/4-20 x 1-1/4"
19	9466R	1	Spring, Blade Adjust	56	43013	3	Hex Lock Nut 1/4-20 Thread
20	44071	1	Bolt, Hex 3/8-16 x 3-1/2"	57	710-0305	2	Carriage Bolt 3/8-16 x 1-1/4"
21	43015	2	Nut, Hex 3/8-16	58	43086	4	Lock Washer 5/16"
22	44074	1	Plastic Cap	59	46065	1	Pivot channel shaft
23	746-0366	1	Control Cable Ass'y	60	10521	1	Lift Link Ass'y
24	62561	1	Release Grip Ass'y	61	43182	4	Bolt, Hex 5/16-18 x 3/4"
25	43055	4	Pin, Hairpin Small 3/32"	62	43407	6	Bolt, Hex 3/8-16 x 3/4"
26	46053	2	Spacer, .28 ID x 1"	63	43001	18	Hex Bolt 3/8-16 x 1"
27	62971	1	Lift Handle Rod Ass'y	64	43054	2	Hex Bolt 3/8-16 x 2"
28	23974	1	Axle Pivot Bracket	65	43087	2	Hex Bolt 3/8-16 x 1-1/4"
29	732-0153	1	Extension Spring	66	43082	26	Hex Lock Nut 3/8-16 Thread
30	10513	1	Pivot Support Bracket	67	43003	26	Lock Washer 3/8"
31	23960	1	Plate, Pivot Support	68	726-0178	2	Plastic Tie
32	23962	1	Frame Pivot Support (RH)	69	R19171616	1	Washer
33	23961	1	Frame Pivot Support (LH)	70	45133	4	Spacer, 1/2" ID x 1" OD
34	23964	1	Bracket, Frame (RH)	71	46071	1	Bolt, Hex 1/4-20 x 3-1/4" Lg. Gr 5
35	23963	1	Bracket, Frame (LH)	72	43349	1	1/4" x 1" Spring Pin
36	46048	1	Brace, Tube (RH)	73	46050	1	Owners Manual
37	46047	1	Brace Tube (LH)				

Sears, Roebuck and Co. reserves the right to make any changes in design or improvements without imposing any obligation to install the same upon its items hereto fore manufactured

# **SEARS**

## **OWNERS MANUAL**

**Model No.  
486.244040**

**HOW TO ORDER  
REPAIR PARTS**

# **CRAFTSMAN**

## **48" SNOW BLADE**

Always mention the Model Number when requesting service or repair parts for your snow blade.

All parts listed herein may be ordered from any Sears Service Center and most Sears stores.

**WHEN ORDERING REPAIR PARTS, ALWAYS GIVE THE FOLLOWING INFORMATION:**

- THE PART NUMBER
- THE PART DESCRIPTION
- THE MODEL NUMBER
- THE NAME OF MERCHANDISE

If the parts you need are not stocked locally, your order will be electronically transmitted to a Sears Repair Parts Distribution Center for handling.

Sears, Roebuck and Co., Hoffman Estates, IL. 60179 U.S.A.