

SAVE THIS MANUAL
FOR FUTURE
REFERENCE

SEARS

*owners
manual*

**MODEL NO.
113.226424**

**BELT AND DISC
SANDER**

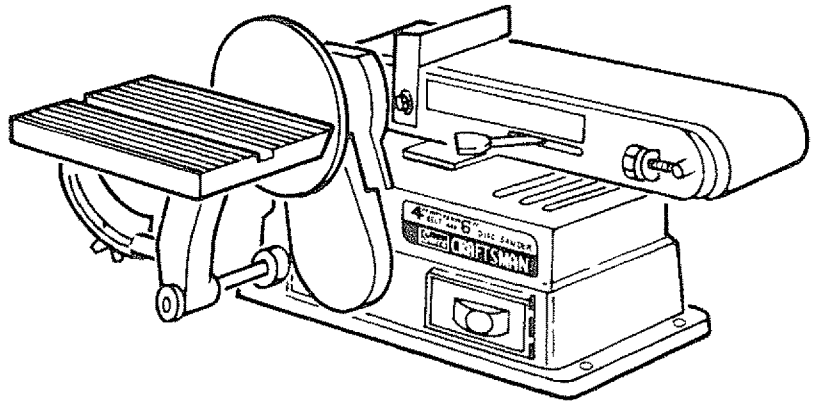

Serial
Number _____

Model and serial
number may be found on
the back side of
the base.

You should record both
model and serial number
in a safe place for
future use.

CAUTION:

Read **GENERAL** and
ADDITIONAL SAFETY
INSTRUCTIONS
carefully

CRAFTSMAN
BELT AND DISC
SANDER

- *assembly*
- *operating*
- *repair parts*

Sold by SEARS, ROEBUCK AND CO., Chicago, IL. 60684 U.S.A.

FULL ONE YEAR WARRANTY ON CRAFTSMAN BELT AND DISC SANDER

If within one year from the date of purchase, this Craftsman Belt and Disc Sander fails due to a defect in material or workmanship, Sears will repair it, free of charge.

WARRANTY SERVICE IS AVAILABLE BY SIMPLY CONTACTING THE NEAREST SEARS SERVICE CENTER/DEPARTMENT THROUGHOUT THE UNITED STATES.

THIS WARRANTY APPLIES ONLY WHILE THIS PRODUCT IS USED IN THE UNITED STATES.

This warranty gives you specific legal rights, and you may also have other rights which vary from state to state.

SEARS, ROEBUCK AND CO., 698/731A, Sears Tower, Chicago, IL 60684

general safety instructions for power tools

1. KNOW YOUR POWER TOOL

Read and understand the owner's manual and labels affixed to the tool. Learn its application and limitations as well as the specific potential hazards peculiar to this tool.

2. GROUND ALL TOOLS

This tool is equipped with an approved 3-conductor cord and a 3-prong grounding type plug to fit the proper grounding type receptacle. The green conductor in the cord is the grounding wire. Never connect the green wire to a live terminal.

3. KEEP GUARDS IN PLACE

— in working order, and in proper adjustment and alignment.

4. REMOVE ADJUSTING KEYS AND WRENCHES

Form a habit of checking to see that keys and adjusting wrenches are removed from tool before turning it on.

5. KEEP WORK AREA CLEAN

Cluttered areas and benches invite accidents. Floor must not be slippery due to wax or sawdust.

6. AVOID DANGEROUS ENVIRONMENT

Don't use power tools in damp or wet locations or expose them to rain. Keep work area well lighted. Provide adequate surrounding work space.

7. KEEP CHILDREN AWAY

All visitors should be kept a safe distance from work area.

8. MAKE WORKSHOP CHILD-PROOF

— with padlocks, master switches, or by removing starter keys.

9. DON'T FORCE TOOL

It will do the job better and safer at the rate for which it was designed.

10. USE RIGHT TOOL

Don't force tool or attachment to do a job it was not designed for.

11. WEAR PROPER APPAREL

Do not wear loose clothing, gloves, neckties or jewelry (rings, wristwatches) to get caught in moving parts. NONSLIP footwear is recommended. Wear protective hair covering to contain long hair. Roll long sleeves above the elbow.

12. USE SAFETY GOGGLES (Head Protection)

Wear safety goggles (must comply with ANSI

Z87.1) at all times. Everyday eyeglasses only have impact resistant lenses, they are NOT safety glasses. Also, use face or dust mask if cutting operation is dusty, and ear protectors (plugs or muffs) during extended periods of operation.

13. SECURE WORK

Use clamps or a vise to hold work when practical. It's safer than using your hand, frees both hands to operate tool.

14. DON'T OVERREACH

Keep proper footing and balance at all times.

15. MAINTAIN TOOLS WITH CARE

Keep tools sharp and clean for best and safest performance. Follow instructions for lubricating and changing accessories.

16. DISCONNECT TOOLS

before servicing; when changing accessories such as blades, bits, cutters, etc.

17. AVOID ACCIDENTAL STARTING

Make sure switch is in "OFF" position before plugging in.

18. USE RECOMMENDED ACCESSORIES

Consult the owner's manual for recommended accessories. Follow the instructions that accompany the accessories. The use of improper accessories may cause hazards.

19. NEVER STAND ON TOOL

Serious injury could occur if the tool is tipped or if the cutting tool is accidentally contacted.

Do not store materials above or near the tool such that it is necessary to stand on the tool to reach them.

20. CHECK DAMAGED PARTS

Before further use of the tool, a guard or other part that is damaged should be carefully checked to ensure that it will operate properly and perform its intended function. Check for alignment of moving parts, binding of moving parts, breakage of parts, mounting, and any other conditions that may affect its operation. A guard or other part that is damaged should be properly repaired or replaced.

21. DIRECTION OF FEED

Feed work into a blade or cutter against the direction of rotation of the blade or cutter only.

22. NEVER LEAVE TOOL RUNNING UNATTENDED

Turn power off. Don't leave tool until it comes to a complete stop.

additional safety instructions for belt and disc sander

Safety is a combination of operator common sense and alertness at all times when the sander is being used.

WARNING: FOR YOUR OWN SAFETY, DO NOT ATTEMPT TO OPERATE YOUR BELT AND DISC SANDER UNTIL IT IS COMPLETELY ASSEMBLED AND INSTALLED ACCORDING TO THE INSTRUCTIONS ... AND UNTIL YOU HAVE READ AND UNDERSTOOD THE FOLLOWING:

	Page
1. General Safety Instructions for Power Tools . 2	
2. Getting to Know Your Sander 11	
3. Basic Operation 13	
4. Maintenance 16	

5. Stability of Machine

If there is any tendency for the machine to tip over or move during certain operations such as when sanding long heavy boards, the sander should be bolted down.

6. Location

The machine should be positioned so neither the operator nor a casual observer is forced to stand in line with the sanding belt or disc. This machine is intended for indoor use only.

7. Kickback

When sanding on the Disc, always apply the workpiece left of center to the left side of the disc. Applying the workpiece to the right side could cause it to fly up (kickback) which could be hazardous. When sanding on the sanding belt, never apply the end of a workpiece to the idler pulley which can result in a kickback.

8. Protection: Eyes, Hands, Face, Ears and Body

- a. Always wear safety goggles (not glasses) that comply with ANSI Z87.1. Wear face shield if operation is dusty. Wear ear plugs or muffs during extended periods of operation. Do not wear gloves, jewelry or watches. Roll long sleeves above the elbow. Tie back long hair.
- b. Do not sand pieces of material too small to hold by hand.
- c. Avoid awkward hand positions, where a sudden slip could cause a hand to move into sanding disc or belt.
- d. Never climb on the machine.
- e. Never turn your Sander "ON" before clearing the belt table and worktable of all objects.

- f. Make sure the sanding belt runs in the right direction (directional arrow on back side of belt). Always have the tracking adjusted correctly so that the belt does not run off the pulleys.
 - g. Hold the work firmly when sanding on the belt and against the worktable when sanding on the disc.
 - h. Always adjust the worktable to within a maximum of 1/16-inch of the sanding disc or belt.
 - i. When sanding a large piece of material, provide additional support at table height.
 - j. Never leave the machine work area when the power is on, before the machine has come to a complete stop, or without removing and storing the switch key.
 - k. Do not perform layout, assembly or setup work on the table while the sander is operating.
 - l. Turn sander "OFF" and remove plug from power supply outlet before installing or removing an accessory.
 - m. Use only RECOMMENDED ACCESSORIES listed on page 19.
 - n. Always keep guards in place when operating sander.
 - o. Tighten securely all work supports before sanding.
9. If any part of this Belt and Disc Sander should break, bend, or fail in any way or any electrical component fail to perform properly, or if any is missing, shut off power switch, remove power supply cord from power supply and replace damaged missing and/or failed parts before resuming operation.
10. Do not sand with the workpiece unsupported. Support it with the backstop or worktable. The only exception is curved work performed on outer end of belt (idler pulley).
11. To avoid entanglement in spindle, do not operate sander with sanding plate and/or guard removed.

CAUTION: This Belt and Disc Sander is designed to sand wood or wood like products only. Attempts to sand or grind other materials could result in fire, injury or damage to the product.

additional safety instructions for belt and disc sander

12. Think Safety

Safety is a combination of operator common sense and alertness at all times when the sander is in operation.



The operation of any power tool can result in foreign objects being thrown into the eyes, which can result in severe eye damage. Always wear safety goggles (not glasses) complying with ANSI Z87.1 (shown on Package) before beginning power tool operation. Safety Goggles are available at Sears retail or catalog stores.

WARNING: DO NOT ALLOW FAMILIARITY (GAINED FROM FREQUENT USE OF YOUR MACHINE) TO BECOME COMMONPLACE. ALWAYS REMEMBER THAT A CARELESS FRACTION OF A SECOND IS SUFFICIENT TO INFLICT SEVERE INJURY.

READ AND FOLLOW THE WARNINGS THAT APPEAR ON THE TOOL:

DANGER

FOR YOUR OWN SAFETY:

1. READ AND UNDERSTAND OWNER'S MANUAL BEFORE OPERATING MACHINE.
2. WEAR SAFETY GOGGLES AND DUST MASK.
3. MAINTAIN 1/16" MAXIMUM CLEARANCE BETWEEN TABLE AND SANDING BELT OR DISC.
4. AVOID "KICKBACK" (WORKPIECE THROWN AT YOU)—DO NOT USE RIGHT HALF OF DISC.
5. ALWAYS SUPPORT WORKPIECE WITH "BACK-STOP" OR "WORKTABLE."
6. DO NOT WEAR GLOVES, NECKTIE OR LOOSE CLOTHING. TIE BACK LONG HAIR.



E82443

motor specifications and electrical requirements

This machine is designed to use, and is equipped with, a **3450 RPM** motor. It is wired for operation on 110-120 volts, 60 Hz., alternating current. (TOOL MUST NOT BE CONVERTED TO OPERATE ON 230 VOLT).

For replacement motor refer to parts list in this manual.

CONNECTING TO POWER SUPPLY OUTLET

This machine must be grounded while in use to protect the operator from electric shock.

Plug power cord into a 110-120V properly grounded type outlet protected by a 15-amp. fuse or circuit breaker.

WARNING: DO NOT PERMIT FINGERS TO TOUCH THE TERMINALS OF PLUGS WHEN INSTALLING OR REMOVING THE PLUG TO OR FROM THE OUTLET.

WARNING: IF NOT PROPERLY GROUNDED THIS POWER TOOL CAN CAUSE AN ELECTRICAL SHOCK PARTICULARLY WHEN USED IN DAMP LOCATIONS CLOSE TO PLUMBING. IF AN ELECTRICAL SHOCK OCCURS THERE IS THE POTENTIAL OF A SECONDARY HAZARD SUCH AS YOUR HANDS CONTACTING THE SANDING SURFACE.

If power cord is worn or cut, or damaged in any way, have it replaced immediately.

Your unit is for use on 110-120 volts, and has a plug that looks like below.

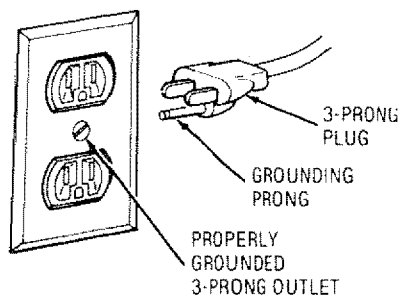

This power tool is equipped with a 3-conductor cord and grounding type plug which has a grounding prong, approved by Underwriters' Laboratories and the Canadian Standards Association. The ground conductor has a green jacket and is attached to the tool housing at one end and to the ground prong in the attachment plug at the other end.

This plug requires a mating 3-conductor grounded type outlet as shown.

If the outlet you are planning to use for this power tool is of the two prong type, DO NOT REMOVE OR ALTER THE GROUNDING PRONG IN ANY MANNER. Use an adapter as shown below and always connect the grounding lug to a known ground.

It is recommended that you have a qualified electrician replace the TWO prong outlet with a properly grounded THREE prong outlet.

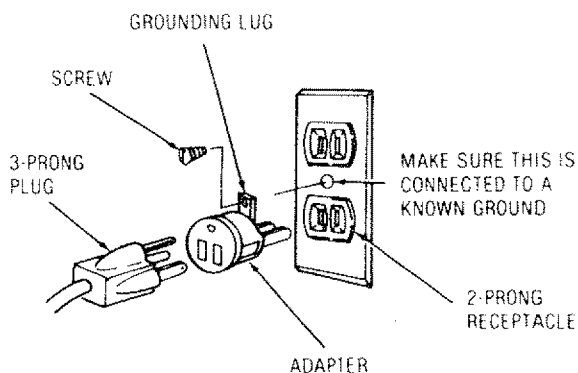

An adapter as illustrated is available for connecting plugs to 2-prong receptacles.

WARNING: THE GREEN GROUNDING LUG EXTENDING FROM THE ADAPTER MUST BE CONNECTED TO A PERMANENT GROUND SUCH AS TO A PROPERLY GROUNDED OUTLET BOX. NOT ALL OUTLET BOXES ARE PROPERLY GROUNDED.

If you are not sure that your outlet box is properly grounded, have it checked by a qualified electrician.

NOTE: The adapter illustrated is for use only if you already have a properly grounded 2-prong receptacle. Adapter is not allowed in Canada by the Canadian Electrical Code.

The use of any extension cord will cause some loss of power. To keep this to a minimum and to prevent overheating and motor burn-out, use the table below to determine the minimum wire size (A.W.G.) extension cord.

Use only 3 wire extension cords which have 3-prong grounding type plugs and 3-prong receptacles which accept the tools plug.

Length of the Conductor	Wire Sizes Required (American Wire Gage Number)
	120V Lines
0 - 25 Feet	No. 14
26 - 100 Feet	No. 12
Over 100 Feet	No. 8

contents

POWER TOOL WARRANTY	2
GENERAL SAFETY INSTRUCTIONS FOR POWER TOOLS	2
ADDITIONAL SAFETY INSTRUCTIONS BELT AND DISC SANDER	3
MOTOR SPECIFICATIONS AND ELECTRICAL REQUIREMENTS	5
UNPACKING AND CHECKING CONTENTS	6
ASSEMBLY	
Mounting Belt and Disc Sander To Workbench	7
Clamping Belt And Disc Sander To Workbench	7
Installing Timing Belt	8
Installing Pulley Cover	9
Installing Sanding Disc Plate	9
Installing Backstop	10
Installing Table Assembly	10

Squaring Table Assembly	11
Replacing The Sanding Belt Tensioning And Tracking	12
GETTING TO KNOW YOUR BELT AND DISC SANDER	
Bevel Sanding	15
Positioning Belt Table	15
Belt Table Stop	16
Surface Sanding On Sanding Belt	16
End Sanding On The Sanding Belt	16
Sanding Curved Edges	17
MAINTENANCE	18
Lubrication	18
TROUBLESHOOTING	19
RECOMMENDED ACCESSORIES	19
REPAIR PARTS	20

unpacking and checking contents

TOOLS NEEDED

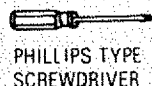
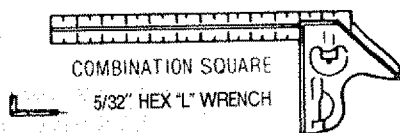
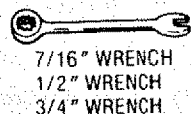

COMBINATION SQUARE MUST BE TRUE

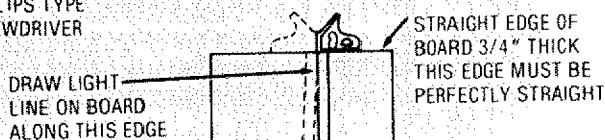

SHOULD BE NO GAP OR OVERLAP HERE WHEN
SQUARE IS FLIPPED OVER IN DOTTED POSITION

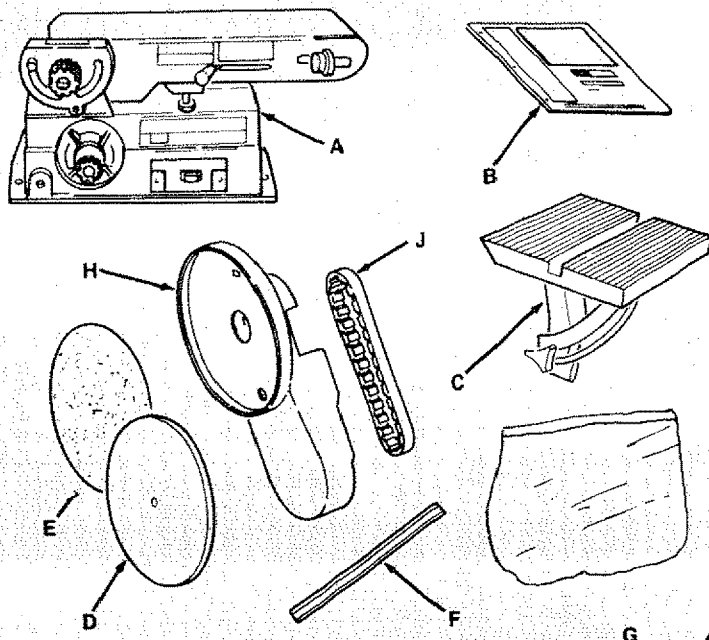

Model 113.226424 Belt and Disc Sander is shipped complete in one carton.

Separate all parts from packing materials and check each item with illustration and "Table of Loose Parts." Make certain all items are accounted for, before discarding any packing material.

If any parts are missing, do not attempt to assemble the Belt and Disc Sander, plug in the power cord, or turn the switch on until the missing parts are obtained and installed correctly.

WARNING: FOR YOUR OWN SAFETY, NEVER CONNECT PLUG TO POWER SOURCE OUTLET UNTIL ALL ASSEMBLY STEPS ARE COMPLETE AND UNTIL YOU HAVE READ AND UNDERSTOOD THE ENTIRE OWNERS MANUAL.

ITEM	TABLE OF LOOSE PARTS	QTY.
A	Belt and Disc Sander Assembly ...	1
B	Owner's Manual	1
C	Table Assembly	1
D	Sanding Plate	1
E	Sanding Disc	1
F	Table Support Rod	1
G	Bag Assembly Part #507771	1
	Containing the following parts:	
	Clamp-Bolt	1
	Switch, Key	1
	Screw Soc. Set 5/16-24X3/8	1
	Wrench, Hex "L" 1/8	1
	Backstop	1
	Washer, 1/4"	1
	Bolt, Hex 1/4-20X1/2	1
	Setscrew 1/4-20X1/4"	1
	Screw 1/4-20X1-3/4"	1
	Lockwasher 1/4"	1
H	Pulley Cover	1
J	Timing Belt	1

assembly

MOUNTING BELT AND DISC SANDER TO WORKBENCH

If belt and disc sander is to be used in a permanent location, it should be fastened securely to a firm supporting surface such as a workbench.

If mounting to a workbench, holes should be drilled through supporting surface of the workbench using dimensions illustrated.

1. Each leg should be bolted securely using 5/16" hex nuts (not included). Screw length should be 1 1/2" plus the thickness of the bench top.
2. Locate and mark the holes where belt and disc sander is to be mounted.

3. Drill (4) 3/8" diameter holes through workbench.
4. Place belt and disc sander on workbench aligning holes in feet with holes drilled in workbench.
5. Insert all four 5/16" screws and tighten.

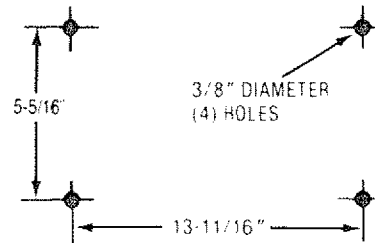

An alternate method of mounting is to fasten belt and disc sander to a mounting board. The board should be of sufficient size to avoid tipping of sander while in use. Any good grade of plywood or chipboard with a 3/4" minimum thickness is recommended. (Thinner chipboard can break.)

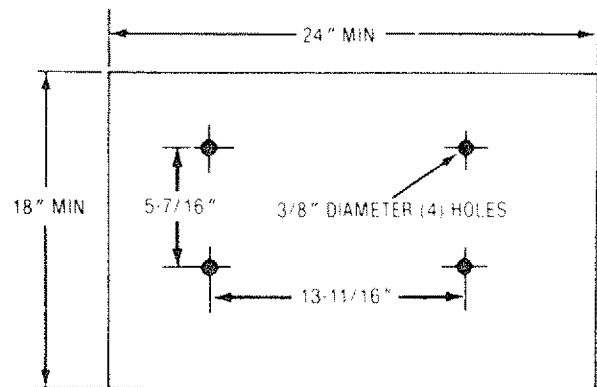

1. Follow instructions for mounting to workbench, substituting a board 18" x 24" minimum size and using 5/16 inch flat head screws, lockwashers, and hex nuts (not included). Screw length should be 1 1/2" plus the thickness of the mounting board.

NOTE: For proper stability, holes must be counter sunk so screw heads are flush with the bottom surface of supporting board.

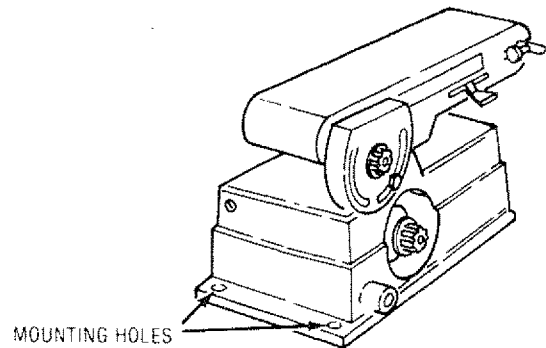

2. Securely clamp board to workbench using "C" clamps.

NOTE: Supporting surface where belt and disc sander is mounted should be examined carefully after mounting to insure that no movement during use can result. If any tipping or walking is noted, secure workbench or supporting surface before operating belt and disc sander.

CLAMPING BELT AND DISC SANDER TO WORKBENCH

The Belt and Disc Sander can be clamped directly to a workbench using two (2) or more "C" clamps on base of unit (one clamp on each end of unit).

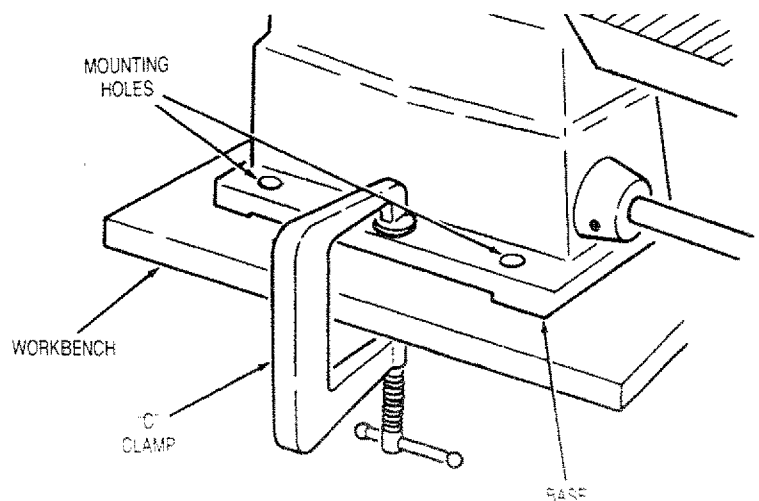

assembly

INSTALLING TIMING BELT

1. Place belt around motor pulley as illustrated.

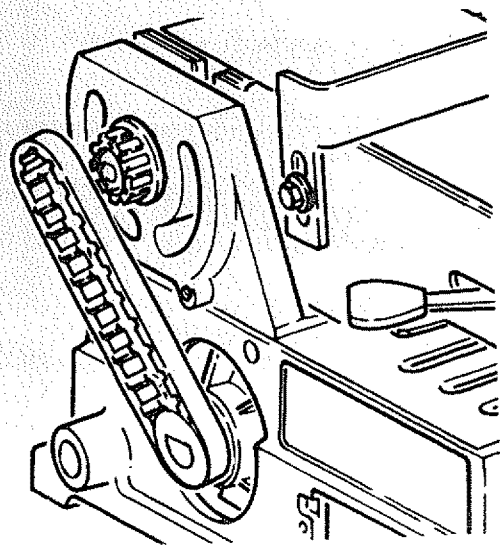

2. Place right hand under motor pulley and lift pulley and belt upward. Using left hand, place belt onto top pulley.

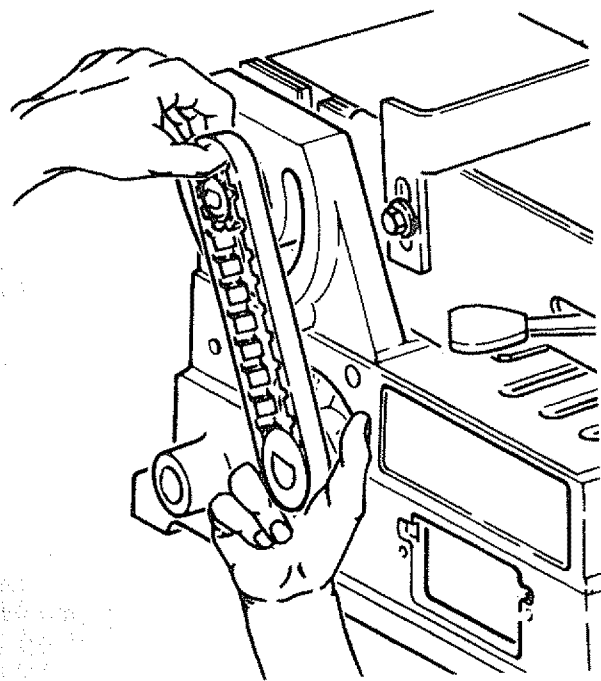

3. The motor is spring loaded so proper tension will be maintained between belt and pulleys at all times.

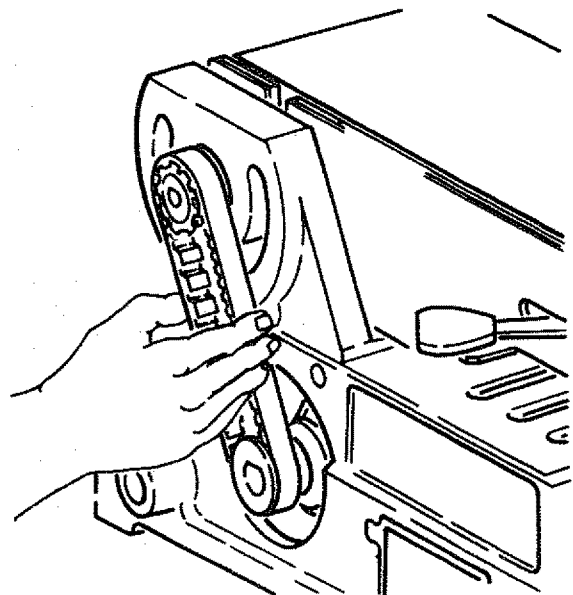

PULLEY COVER

INSTALLING PULLEY COVER

1. Locate the pulley cover and one screw 1/4-20x1-3/4"
2. Place pulley cover into position shown and fasten with one screw. Do not overtighten.

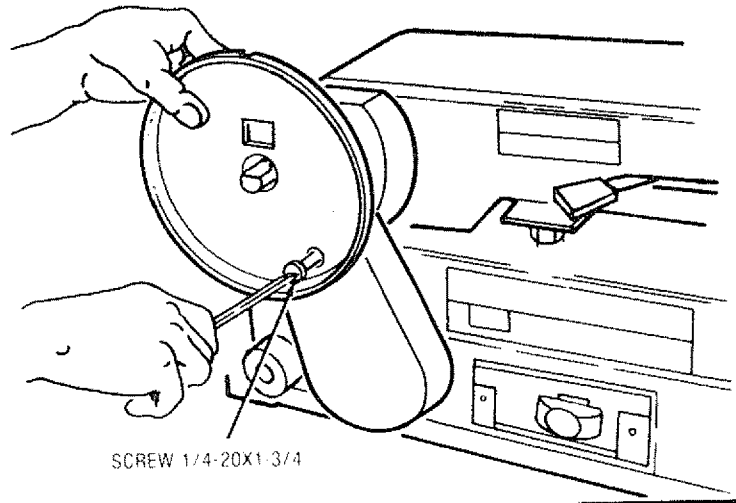

INSTALLING SANDING DISC PLATE

1. Locate sanding disc plate, sanding disc, one setscrew 1/4-20x1/4 inch, and a 1/8 inch hex wrench.
2. Just start screw into threaded hole in sanding plate.

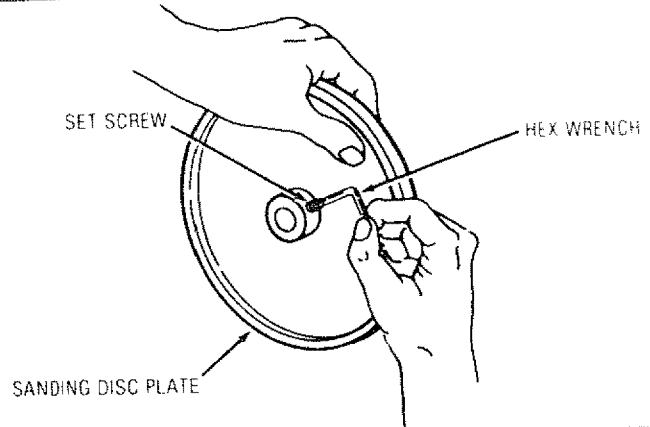

3. Align flat on shaft with setscrew in sanding plate. Slide sanding plate onto shaft until plate surface and shaft are nearly flush. Do not allow shaft to extend out past surface of sanding plate or damage may occur to your sanding disc during operation.

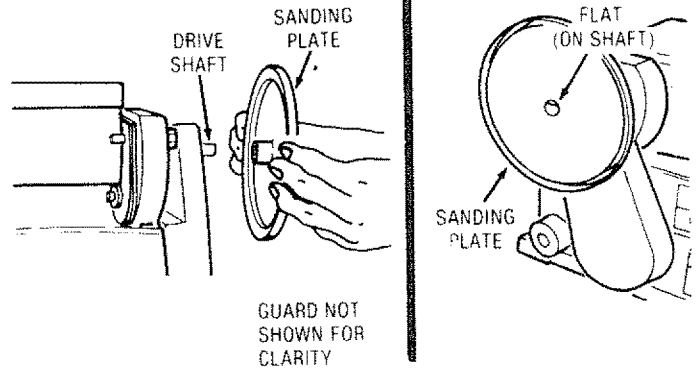

4. To tighten setscrew, reach through hole in top of pulley cover with hex wrench. Tighten setscrew very firmly.

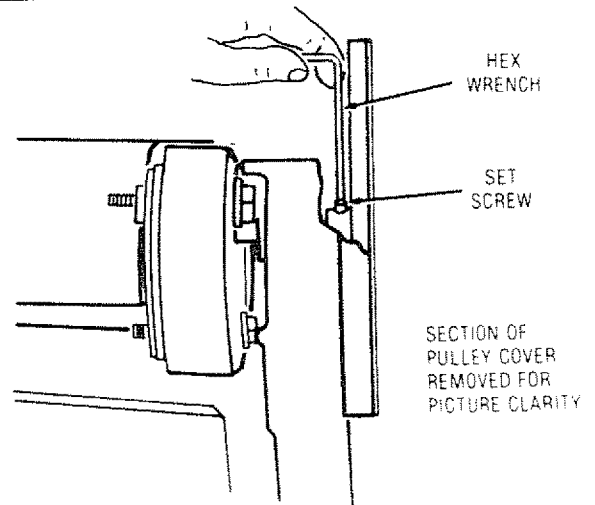

assembly

5. Locate sanding disc and peel backing from disc. Align perimeter of disc with plate and press disc firmly into position all the way around.

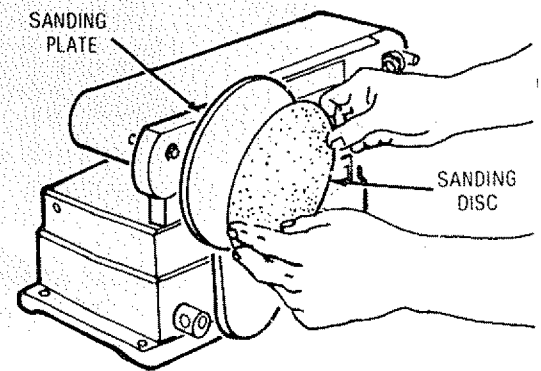

INSTALLING BACKSTOP

1. Locate backstop, hex bolt $\frac{1}{4}$ -20x $\frac{1}{2}$ inch lock-washer, and a $\frac{1}{4}$ inch flat washer.
2. Hold backstop into position and fasten with bolt and washer as shown. Do not overtighten.

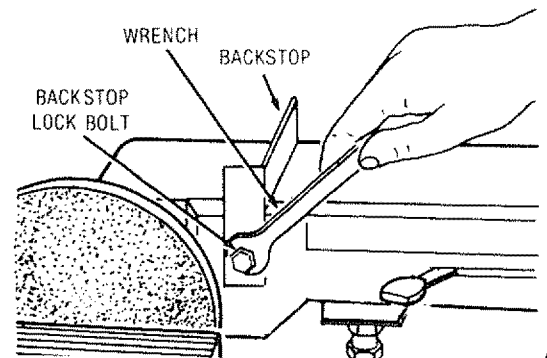

INSTALLING TABLE ASSEMBLY

1. Locate table support rod, set screw and toggle bolt among loose parts.
2. Insert rod in base as shown, leaving 5 inches of rod extending outside base. Rotate rod so flat surface on rod faces toward on-off switch.

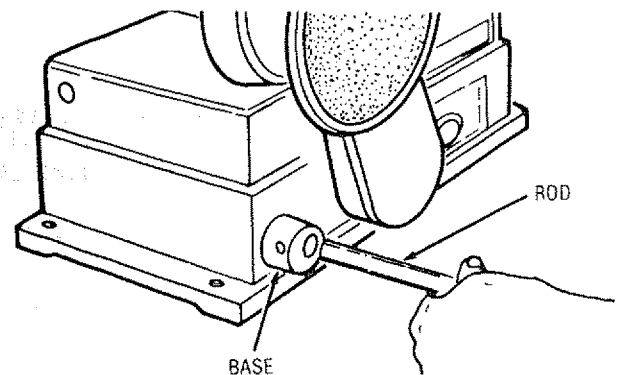

3. Install toggle bolt in base and tighten.

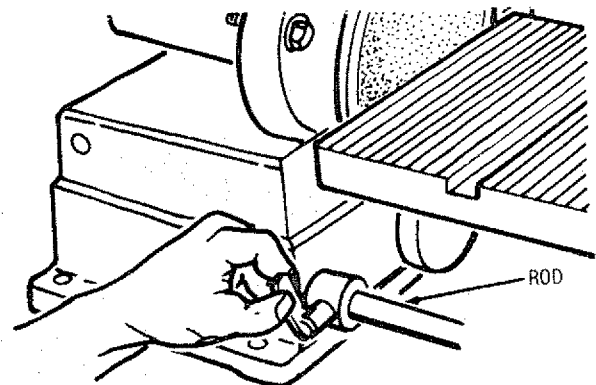

- Slide table assembly onto rod.

WARNING: TO AVOID TRAPPING THE WORK OR FINGERS BETWEEN THE TABLE AND SANDING SURFACE, THE TABLE EDGE SHOULD BE A MAXIMUM OF 1/16-INCH FROM SANDING SURFACE. TABLE ASSEMBLY SHOULD BE COMPLETELY ENGAGED ON ROD.

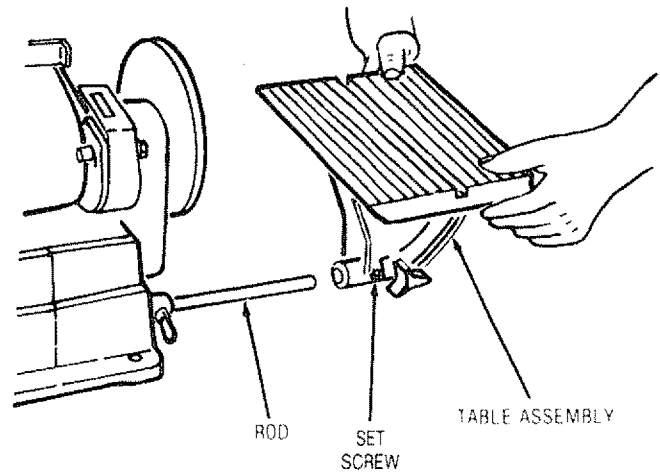

- Install and tighten set screw with Allen (Hex) wrench.
- There is an auxillary mounting hole in the base. This is for mounting the table when the belt is used in a vertical position by moving the complete rod/worktable assembly and toggle bolt. Note and follow the above **WARNING** for table clearance.

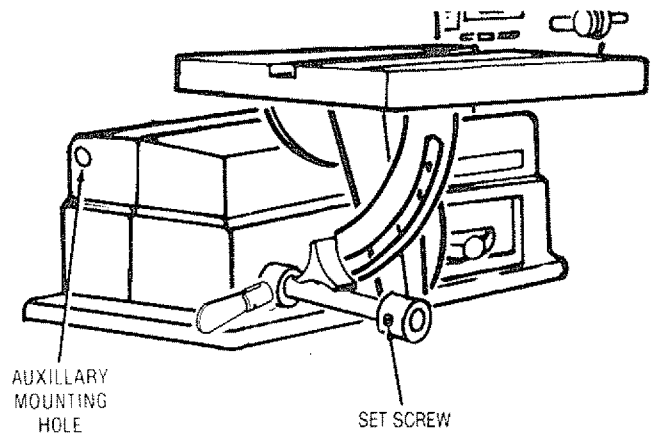

SQUARING TABLE ASSEMBLY

WARNING: TO AVOID INJURY FROM ACCIDENTAL START, MAKE SURE TOOL IS UNPLUGGED BEFORE ALIGNING.

- Using a combination square, check the angle of the worktable with the disc.

NOTE: The combination square must be "true" — See start of assembly section on Pg. 6 for checking method.

- If the table is not 90° with the disc . . . loosen table lock knob screw and tilt table.
- Adjust worktable square to the disc and re-tighten table lock knob.
- Adjust pointer to 0° mark on trunnion with phillips screwdriver if necessary.

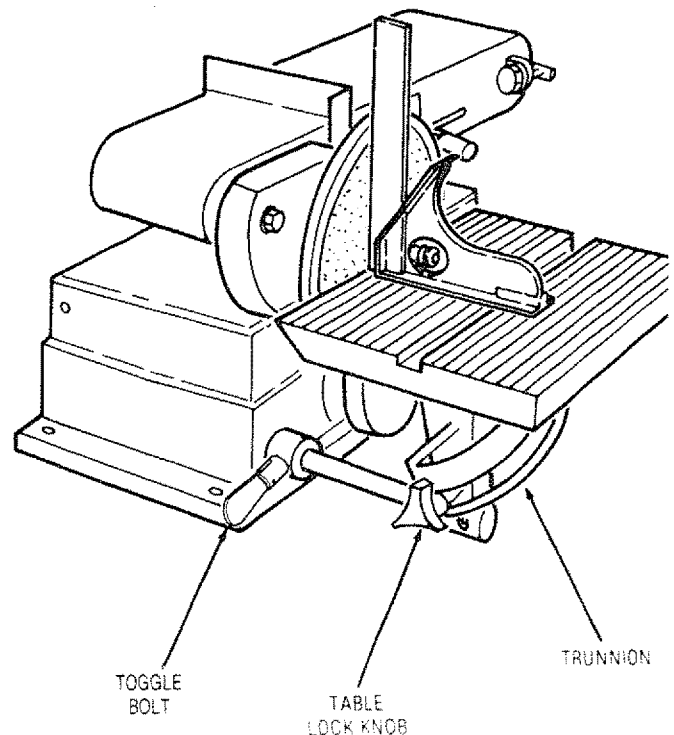

assembly

NOTE: This unit comes with the sanding belt installed.

REPLACING THE SANDING BELT— TENSIONING AND TRACKING

WARNING: TO AVOID INJURY FROM ACCIDENTAL START, TURN SWITCH "OFF" AND REMOVE PLUG FROM POWER SOURCE OUTLET BEFORE REMOVING OR INSTALLING SANDING BELT. USE ONLY SEARS RECOMMENDED SANDING BELTS. SEE SEARS CATALOG.

On the smooth side of the sanding belt you will find a "directional arrow." The sanding belt must run in the direction of this arrow so that the splice does not come apart.

1. Slide tension knob to the right to release the belt tension.
2. Place the sanding belt over the pulleys with the directional arrow pointing as shown. Make sure the belt is centered on both pulleys.

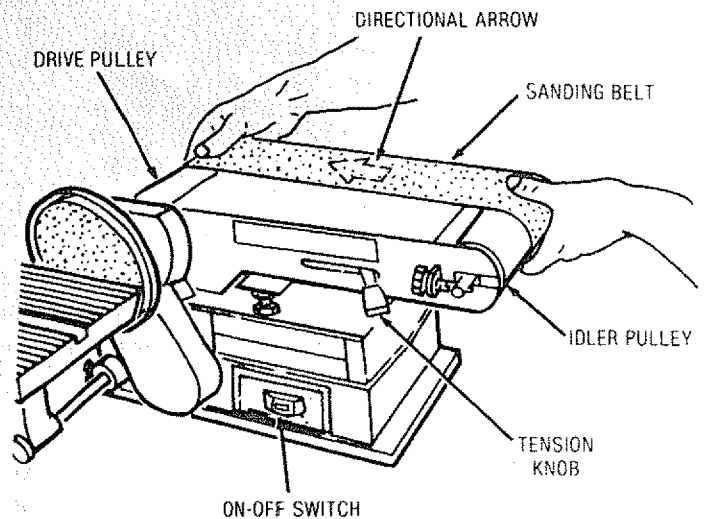

3. Slide tension knob to the left to apply belt tension.
4. Plug in the power cord. Turn switch "ON" and immediately "OFF", noting if the belt tends to slide off the idler pulley or drive pulley. If it did not tend to slide off, it is TRACKING properly.

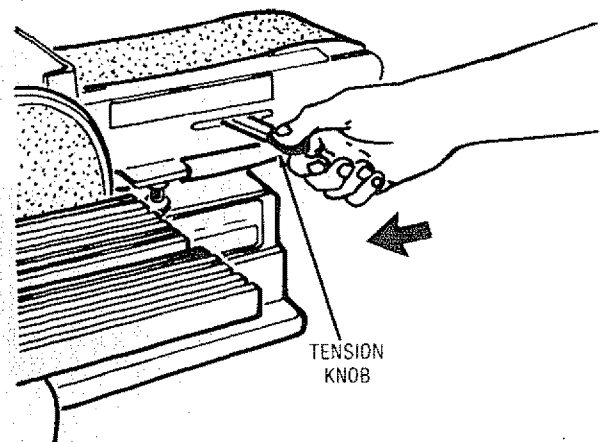

5. If the sanding belt moves toward the disc, turn the tracking knob counterclockwise 1/4 turn.
6. If the sanding belt moves away from the disc, turn the tracking knob clockwise 1/4 turn.
7. Turn switch "ON" and immediately "OFF" again, noting belt movement. Readjust tracking knob if necessary.

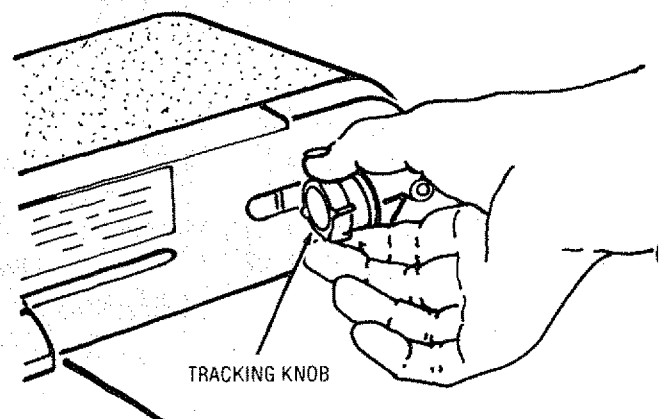

getting to know your belt and disc sander

WARNING: TO AVOID INJURY FROM ACCIDENTAL START, TURN SWITCH "OFF" AND REMOVE PLUG FROM POWER SOURCE OUTLET BEFORE MAKING ANY ADJUSTMENTS.

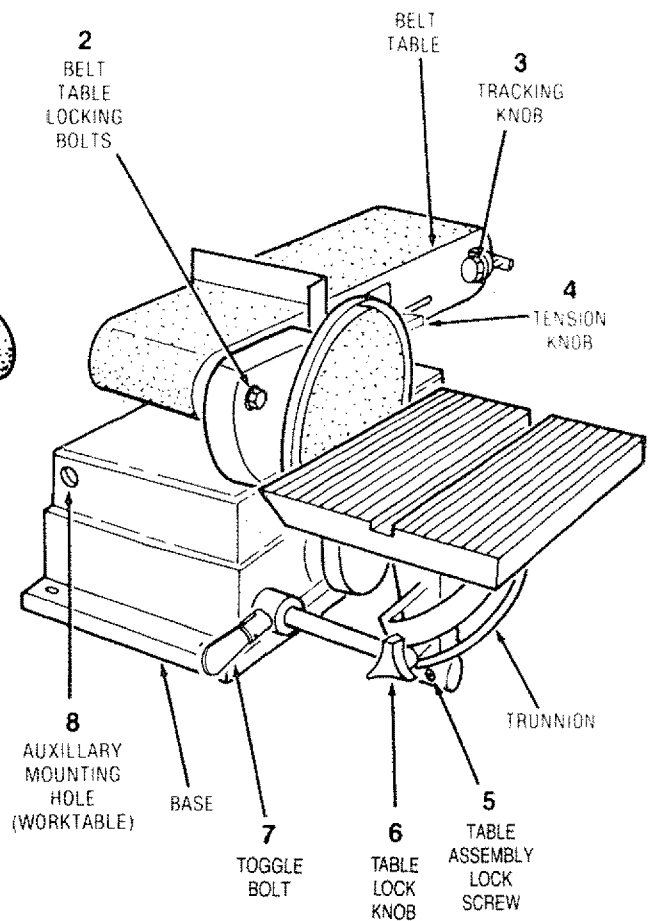
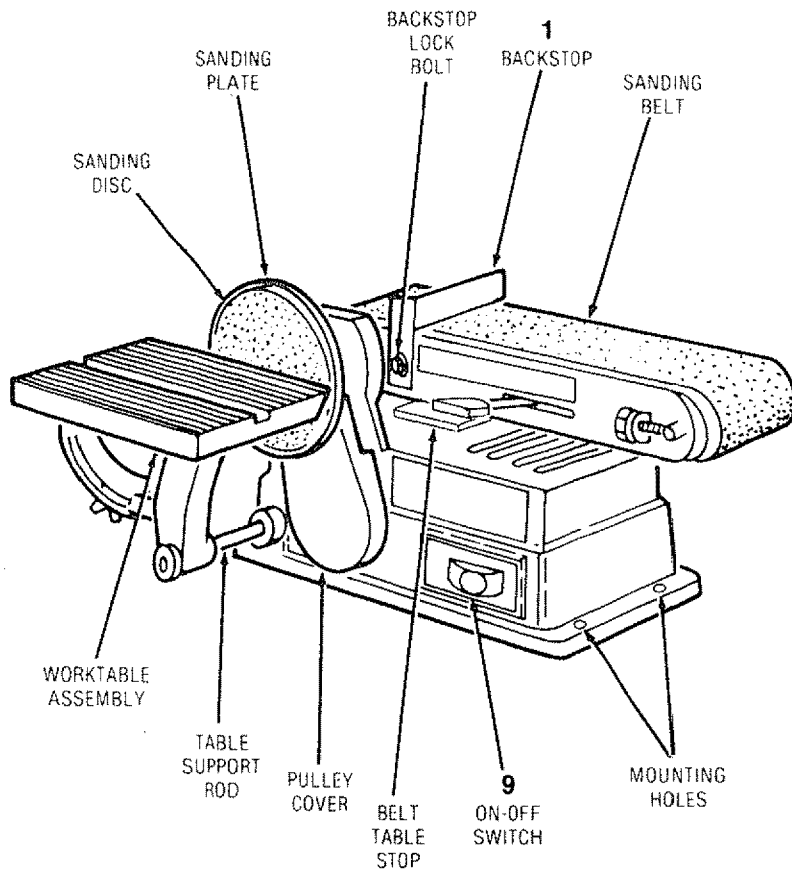

1. Backstop . . . Supports the workpiece on the sanding belt.
2. Belt Table Locking Bolts . . . Loosening bolts allows belt table to be raised to the vertical position.
3. Tracking Knob . . . Turning knob clockwise causes sanding belt to move towards the disc; turning knob counterclockwise causes sanding belt to move away from the disc.
4. Tension Knob . . . Sliding knob to the right releases the sanding belt tension; sliding knob to the left applies belt tension.
5. Table Assembly Lock Screw . . . Locks the table assembly onto the table support rod.
6. Table Lock Knob . . . Loosening knob allows the worktable to be tilted for bevel sanding (Scale on table trunnion).
7. Toggle Bolt Locks the rod into the base.
8. Auxillary Mounting Hole . . . Allows table assembly to be mounted for end sanding on the belt side.

getting to know your belt and disc sander

9. ON-OFF SWITCH

The On-Off Switch has a locking feature. THIS FEATURE IS INTENDED TO HELP PREVENT UNAUTHORIZED AND POSSIBLY HAZARDOUS USE BY CHILDREN AND OTHERS.

1. To turn machine "ON" insert key into switch.

NOTE: Key is made of yellow plastic; locate in loose parts bag.

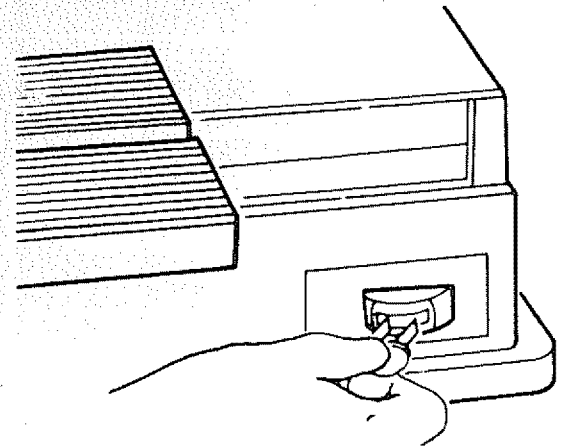

2. Insert finger under switch lever and pull end of switch out.

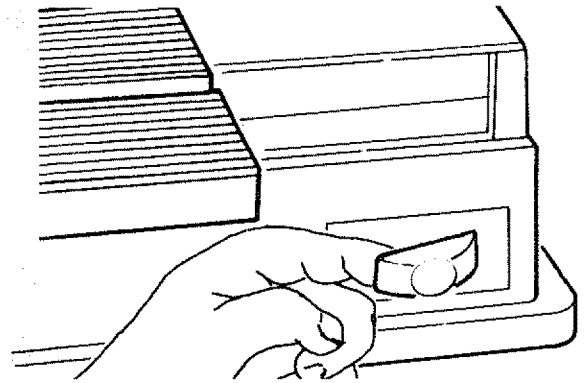

3. To turn machine "OFF" . . . PUSH lever in.

NEVER LEAVE THE MACHINE UNATTENDED UNTIL IT HAS COME TO A COMPLETE STOP.

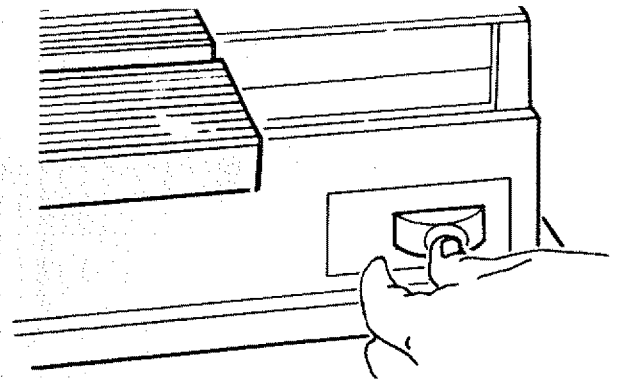

4. To lock switch in OFF position . . . hold switch IN with one hand . . . REMOVE key with other hand.

WARNING: FOR YOUR OWN SAFETY, ALWAYS LOCK THE SWITCH "OFF" WHEN MACHINE IS NOT IN USE . . . REMOVE KEY AND KEEP IT IN A SAFE PLACE . . . ALSO . . . IN THE EVENT OF A POWER FAILURE (ALL OF YOUR LIGHTS GO OUT) TURN SWITCH OFF . . . REMOVE THE KEY AND STORE IT REMOTE FROM BELT AND DISC SANDER. THIS WILL PREVENT THE MACHINE FROM STARTING UP AGAIN WHEN THE POWER COMES BACK ON.

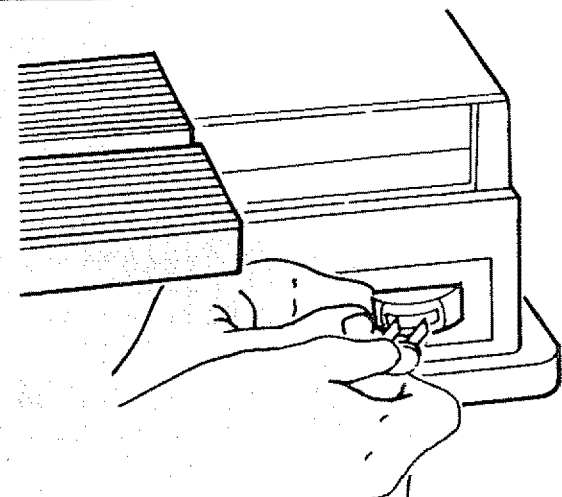

basic operation

BEVEL SANDING

The worktable can be tilted from 0° - 45° for bevel sanding. Loosen the table lock knob and tilt the worktable to desired angle as shown. Retighten table lock knob.

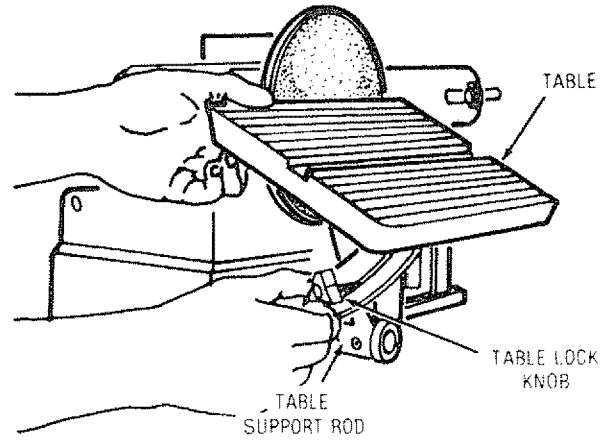

Loosen rod locking toggle bolt. Slide table in so the table is no more than 1/16" from the sanding surface.

WARNING: TO AVOID TRAPPING THE WORK OR FINGERS BETWEEN THE TABLE AND SANDING SURFACE, THE TABLE SHOULD BE RE-POSITIONED ON THE TABLE SUPPORT ROD TO RETAIN A MAXIMUM OF 1/16-INCH DISTANCE BETWEEN SANDING SURFACE AND TABLE.

Retighten rod locking toggle bolt.

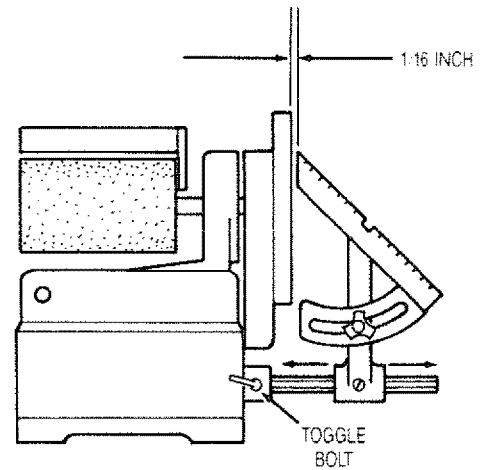

POSITIONING BELT TABLE

Two belt table locking bolts lock the belt table in a vertical or horizontal position.

To adjust vertical position:

- Remove the backstop.
- Loosen the two belt table locking bolts using a 1/2-inch wrench.

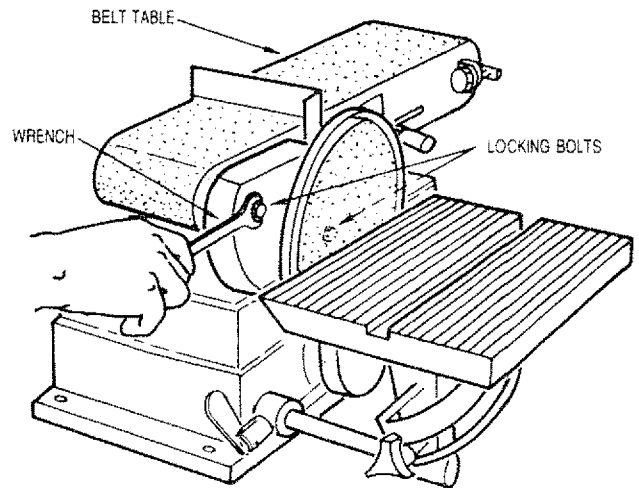

- Position belt table vertically as shown and tighten the two bolts.

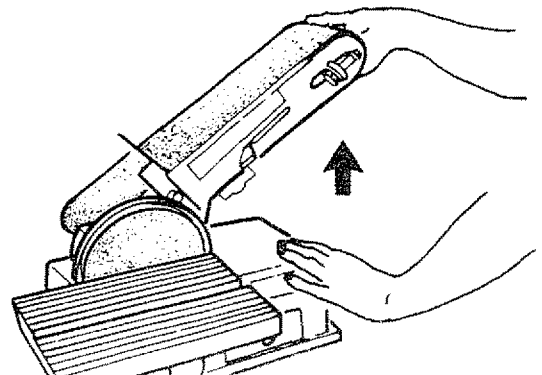

basic operation

BELT TABLE STOP CAN BE ADJUSTED SO THAT THE ABRASIVE BELT TABLE IS LEVEL WITH THE FLOOR WHEN IN A HORIZONTAL POSITION.

- Loosen the lock nut using a 3/4-inch wrench.
- Place a level on the abrasive belt table and using a 3/4-inch wrench, screw the stop bolt in or out until the belt table is level.
- Tighten the lock nut.

 Arrow shows direction of rotation

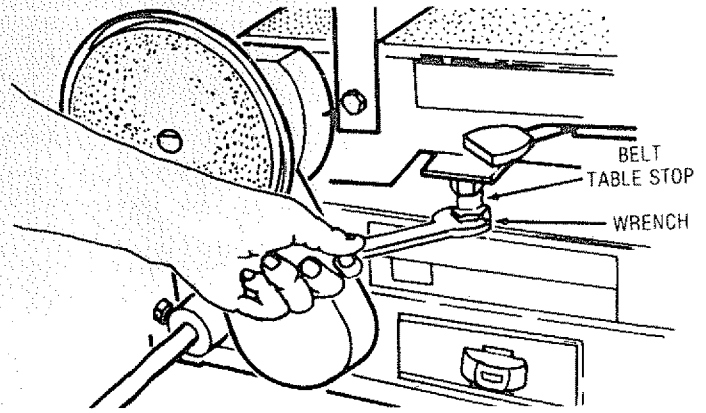

SURFACE SANDING ON THE SANDING BELT

Hold the workpiece firmly with both hands, keeping fingers away from the sanding belt.

Keep the end butted against the backstop and move the work evenly across the sanding belt. Use extra caution when sanding very thin pieces.

For sanding long pieces, remove the backstop.

Apply only enough pressure to allow the sanding belt to remove material.

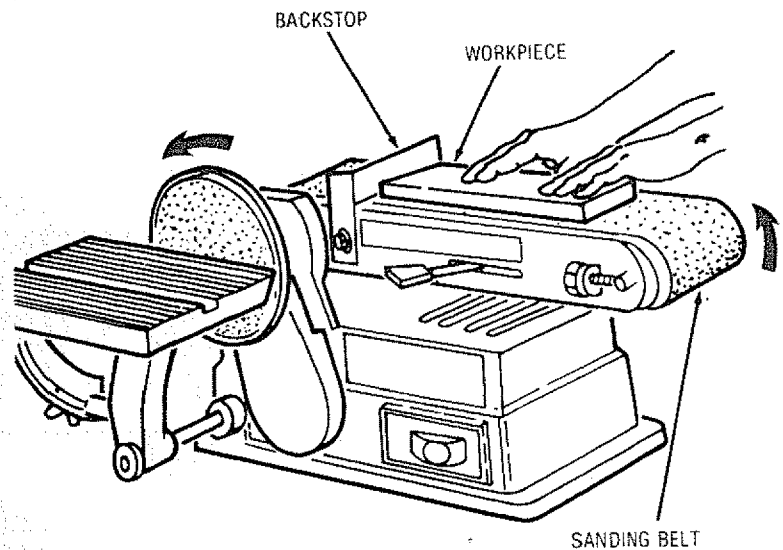

END SANDING ON THE SANDING BELT

It is more convenient to sand the ends of long workpieces with sanding belt in a vertical position.

See "Basic Operation - Positioning Belt Table" for adjusting the belt table, and see "Assembly - Installing Table Assembly" for adjusting worktable.

Move the work evenly across the sanding belt. For accuracy, use a miter gauge (accessory).

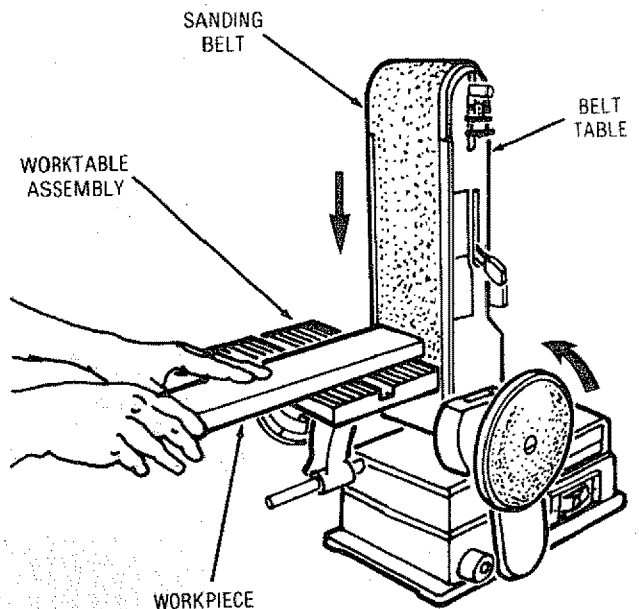

SANDING CURVED EDGES

CURVED EDGES

Always sand inside curves on the idler pulley as shown.

WARNING: NEVER ATTEMPT TO SAND THE ENDS OF A WORKPIECE ON THE IDLER PULLEY. APPLYING THE END OF THE WORKPIECE TO THE IDLER PULLEY COULD CAUSE IT TO FLY UP AND RESULT IN AN INJURY.

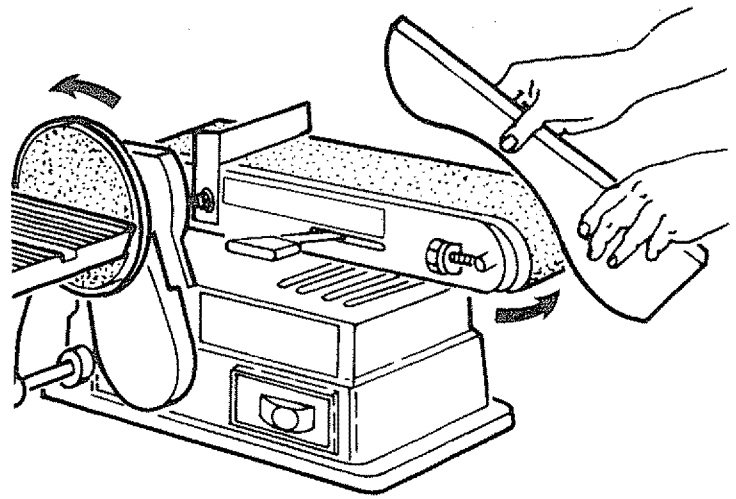

Always sand outside curves on the left side of center on the sanding disc as shown.

WARNING: APPLYING THE WORKPIECE TO THE RIGHT SIDE OF THE DISC COULD CAUSE IT TO FLY UP (KICKBACK) AND RESULT IN AN INJURY.

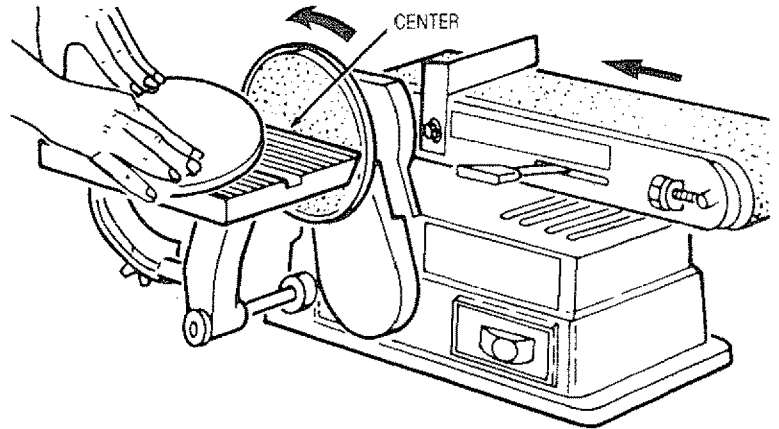

SANDING SMALL END SURFACES ON THE SANDING DISC

Always move the work across left side of center on the sanding disc face as shown.

WARNING: APPLYING THE WORKPIECE TO THE RIGHT SIDE OF THE DISC COULD CAUSE IT TO FLY UP (KICKBACK) AND RESULT IN AN INJURY.

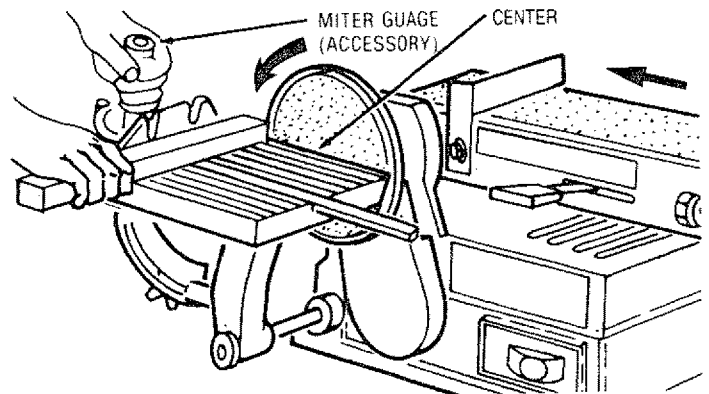

NOTE: Use a combination square to square the miter gauge to the face of the disc (combination square must be "true" — See Start of Assembly section on page 6 for checking method). If it is not square, loosen the miter gauge knob and move the miter gauge slightly until it is square. Without moving the miter gauge, tighten the knob securely.

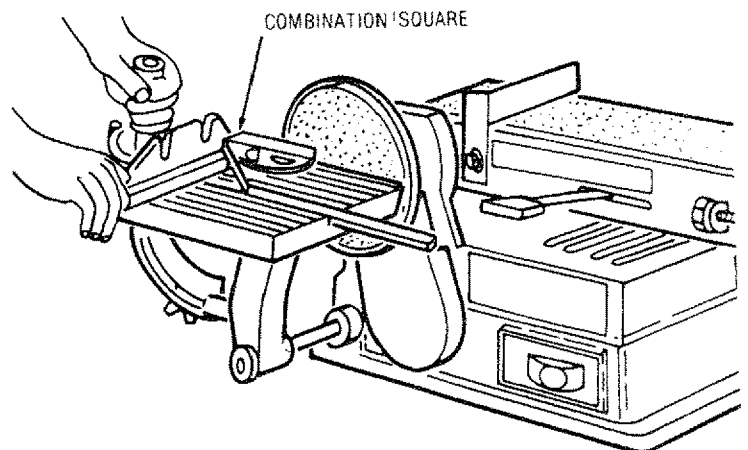

basic operation

WARNING: APPLYING THE WORKPIECE TO THE RIGHT SIDE COULD CAUSE IT TO FLY UP (KICKBACK) WHICH COULD BE HAZARDOUS.

Always position the workpiece to the left of center on sanding disc with disc rotating counter-clockwise as shown.

The table may be tilted for beveled work.

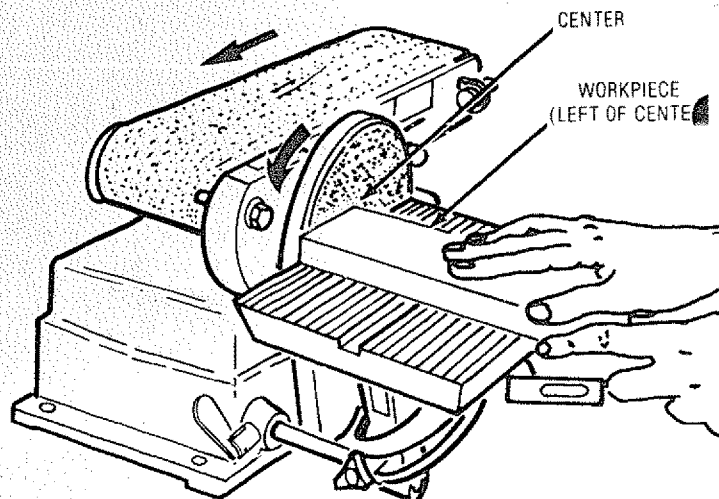

maintenance

WARNING: FOR YOUR OWN SAFETY, TURN SWITCH "OFF" AND REMOVE PLUG FROM POWER SOURCE OUTLET BEFORE ADJUSTING, MAINTAINING, OR LUBRICATING YOUR BELT AND DISC SANDER.

If power cord is worn or cut, or damaged in any way, have it replaced immediately.

Frequently blow out or vacuum out any dust that may accumulate inside the motor.

A coat of automobile-type wax applied to the worktable will make it a little easier to feed the work while finishing.

Do not apply wax to the abrasive belt table because the belt could pick up the wax and deposit it on the pulleys, causing the belt to slip.

LUBRICATION

The BALL BEARINGS in this machine are packed with grease at the factory. They require no further lubrication.

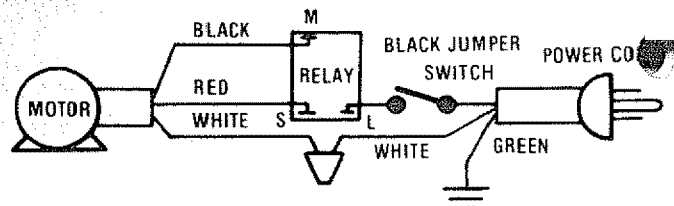

WIRING DIAGRAM

trouble shooting

WARNING: FOR YOUR OWN SAFETY, TURN SWITCH "OFF" AND REMOVE PLUG FROM POWER SOURCE OUTLET BEFORE TROUBLE SHOOTING YOUR SANDER.

TROUBLE	PROBABLE CAUSE	REMEDY
Motor will not run.	<ol style="list-style-type: none"> 1. Defective On-Off switch. Defective switch cord. Defective switch box. 2. Burned out motor. 	<ol style="list-style-type: none"> 1. Replace defective parts before using belt disc sander again. 2. Consult Sears Service. Any attempt to repair this motor may create a HAZARD unless repair is done by a qualified service technician. Repair service is available at your nearest Sears Store.
Machine slows down when sanding.	<ol style="list-style-type: none"> 1. Timing belt too tight. 2. Applying too much pressure to workpiece. 	<ol style="list-style-type: none"> 1. Decrease belt tension, see Assembly Section. 2. Ease up on pressure.
Sanding Belt runs off pulleys.	<ol style="list-style-type: none"> 1. Not tracking properly. 	<ol style="list-style-type: none"> 1. Adjust tracking, see Assembly Section, "Replacing the Sanding Belt — Tensioning and Tracking"
Wood burns while sanding.	<ol style="list-style-type: none"> 1. Sanding disc or belt is glazed with sap. 	<ol style="list-style-type: none"> 1. Replace disc or belt.

RECOMMENDED ACCESSORIES

ITEM	CAT. NO.
Miter Gauge.....	9-24214
Sanding Belts and discs.....	See Catalog
Leg Set.....	9-22244

The above recommended accessories are current and were available at the time this manual was printed.

**PARTS LIST FOR CRAFTSMAN BELT AND DISC SANDER
MODEL NO. 113.226424**

repair parts

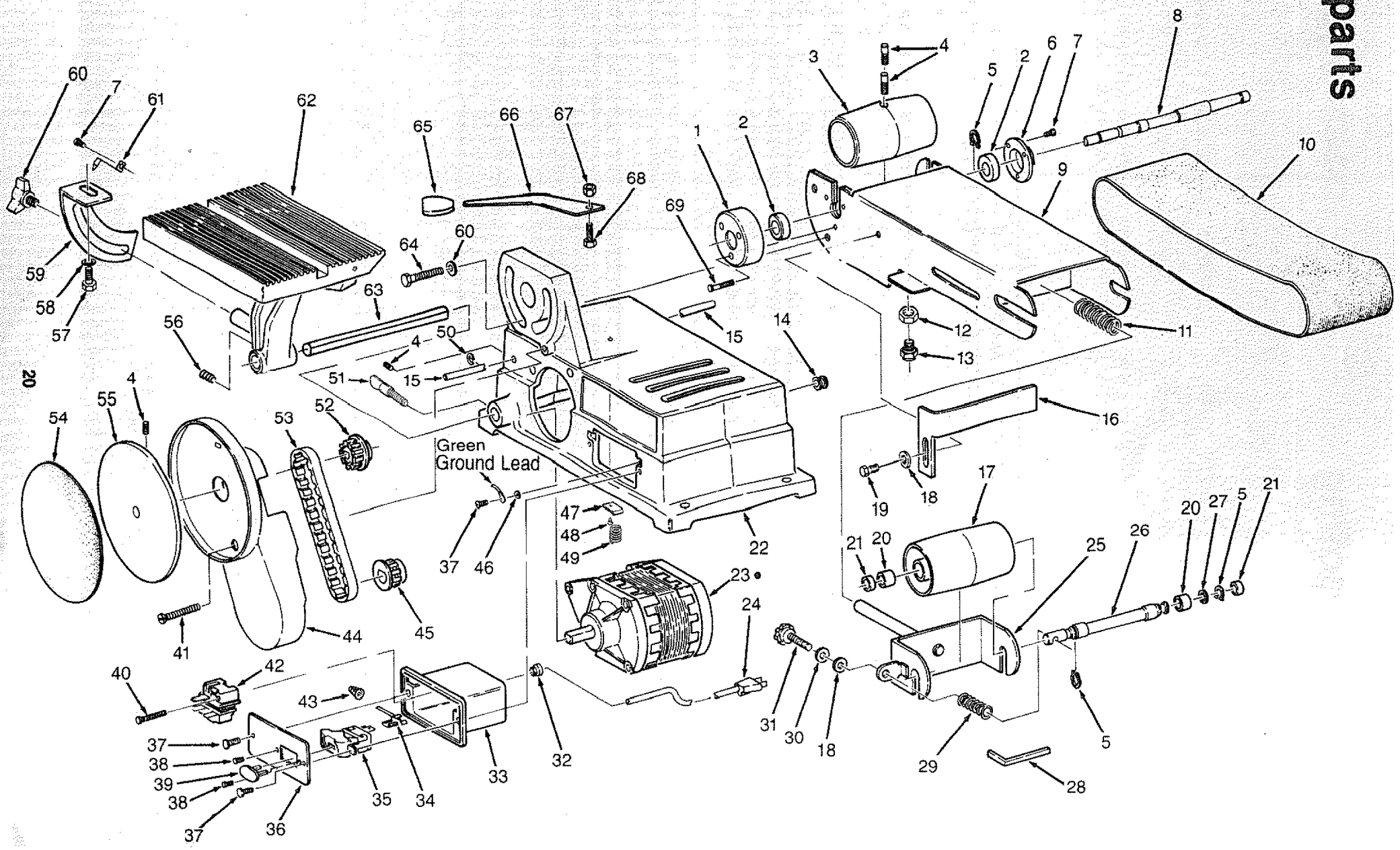

PARTS LIST FOR CRAFTSMAN BELT AND DISC SANDER MODEL NO. 113.226424

Always order by part no. and description — not by key no.

Key No.	Part No.	Description
1	813914	Support-Bearing
2	814101	Bearing-Ball
3	813909	Pulley-Drive
4	STD502502	*Screw-Set, Hex, Cup 1/4-20x1/4
5	805642-6	Ring-Retaining
6	813915	Cap-Bearing
7	STD511002	*Screw-Pan Cross 10-24x1/4
8	813920	Shaft-Drive
9	813913	Table, Belt
10	814110	†Belt-Sanding
11	813948	Spring-Belt Tension
12	STD541250	*Nut Hex Jam 1/2-13
13	813921	Screw-Stop
14	814586	Grommet-Rubber
15	814069	Rod-Motor
16	813911	Stop-Back
17	813919	Pulley-Idler
18	STD551025	*Washer 17/64x9/16x1/16
19	STD522505	*Screw-Hex 1/4-20x1/2
20	813918	Bearing-Sleeve
21	814111	Sleeve-Rubber
22	817083	Base-Belt Sander
23	814109	●Motor
24	814108	Cord w/plug
25	813912	Guide-Drum
26	813910	Shaft-Idler
27	814596	Washer, Wave
28	30505	WRENCH HEX "L" 1/8
29	813947	Spring Tracking
30	814669	Washer, Rubber
31	814103	Knob-Tracking Adv.
32	169123-10	Relief-Strain
33	814049	Housing-Switch
34	63837	Lead Asm-Black
35	62442	Switch-Locking
36	814071	Panel-Switch Trim

Key No.	Part No.	Description
37	STD510805	*Screw-Pan Cross 8-32x1/2
38	STD510602	*Screw-Pan Cross 6-32x1/4
39	60256	Key-Switch
40	809169-4	Screw-Pan, HD TY T8-32x1-1/4
41	STD512515	*Screw-Pan HD 1/4-20x1-3/4
42	814589	Relay
43	803709	Connector-Wire
44	814739	Cover-Pulley
45	814105	Pulley-Timing Belt
46	STD551208	*Lockwasher Ext N8
47	817079	Clip-Spring Retaining
48	STD600603	*Screw Pan, HD TY "T" 6-32x3/8
49	817078	Spring
50	STD581025	*Ring-Retaining 1/4
51	817082	Clamp-Bolt
52	814106	Pulley-Timing Belt
53	814002-1	Belt-Timing
54	814107	†Disc-Sanding
55	813917	Plate-Sanding
56	141669-14	Soc. Set Cup Pt. 5/16-24x3/8
57	805466-2	Screw-Hex 5/16-18x9/16
58	STD551031	*Washer 21/64x9/16x1/16
59	814093	Trunnion
60	814091	Knob
61	814089	Pointer
62	507772	Table Support Asm.
63	814090	Rod-Table Support
64	STD523115	*Screw-Hex 5/16-18x1-1/2
65	814362	Knob-Belt Tension
66	813916	Lever-Belt Tension
67	161255-6	Nut-Lock 1/4-20
68	STD522510	*Screw-Hex 1/4-20x1
69	STD511007	*Screw-Pan Cross 10-24x3/4
—	SP5137	Owner's Manual (Not Illus.)
—	507771	Bag of Loose Parts (Not Illus.)

- Any Attempt To Repair This Motor May Create A Hazard Unless Repair Is Done By A Qualified Service Technician.
Repair Service Is Available At Your Nearest Sears store.
- * Standard Hardware Items — May Be Purchased Locally.
- † Stock Item — May Be Purchased Through The Hardware Department Of Most Sears Retail Stores Or Catalog Order Houses.

Notes:

Notes:

SEARS

**owners
manual**

SERVICE

**MODEL NO.
113.226424**

HOW TO ORDER REPAIR PARTS

BELT AND DISC SANDER

Now that you have purchased your Belt & Disc Sander should a need ever exist for repair parts or service, simply contact any Sears Service Center and most Sears, Roebuck and Co. stores. Be sure to provide all pertinent facts when you call or visit.

The model number of your Belt and Disc Sander will be found on a plate attached to your sander on the back side of the base.

**WHEN ORDERING REPAIR PARTS, ALWAYS
GIVE THE FOLLOWING INFORMATION:**

PART NUMBER	PART DESCRIPTION
MODEL NUMBER 113.226424	NAME OF ITEM Belt And Disc Sander

All parts listed may be ordered from any Sears Service Center and most Sears stores. If the parts you need are not stocked locally, your order will be electronically transmitted to a Sears Repair Parts Distribution Center for handling.

Sold by SEARS, ROEBUCK AND CO., Chicago, IL. 60684 U.S.A.