

# COMMERCIAL DRYERS



## Featuring Mechanical Controls



Coin slide and coin vault not included.

### FOR YOUR CUSTOMERS

- Large Capacity is Ideal for Family-Size Loads
- Increased Capacity Allows Large Loads to Tumble and Spread, Reducing Dry Time
- 3 Cycle Options: Heavy Duty, Normal and Delicates
- 180°-Wide-Opening Side-Swing Door Allows for Convenient Access
- Ergonomic Control Knobs

### DUAL OPERATING THERMOSTATS

For best, accurate temperature control.

### LARGE CAPACITY MONEY BOX

- Larger Coin Box for Reduced Collections
- Accepts Coin Slide, Coin-Drop, Card Reader and Non-Coin Payment Configurations



## CEM2763BQ—27" Electric Dryer with Metercase CGM2763BQ—27" Gas Dryer with Metercase YCEM2763BQ—27" Electric Dryer with Metercase

- Dryer Accepts the Following Compatible Payment Systems (not included):
  - Coin Slide
  - Coin-Drop
  - Card Reader
  - Non-Coin Payment Configurations
- 7.4-Cu.-Ft. Drum Capacity
- Ergonomic Control Knobs
- 3 Cycles: Heavy Duty, Normal, Delicates
- 180°-Wide-Opening Reversible Side-Swing Door
- Porcelain Top and Lid, Rustproof Stainless Steel Torx® Control Panel Security Screws
- Front Service Accessibility
- 4-Way, Multi-Vent Options
- Electric Model Features Element Rated 5600 Watts, 240 Volt
- 1/3 HP Motor
- Power Cord Sold Separately (Electric Model Only)
- **3-Year Limited Parts Only Warranty\***

\*Call 1-800-662-3587 for warranty details.

# COMMERCIAL DRYERS



## Featuring Mechanical Controls

### Whirlpool® Commercial Dryers Mechanical Controls

DRYER SPECIFICATIONS		
MODELS	CEM2763BQ/YCEM2763BQ	CGM2763BQ
<b>GENERAL INFORMATION</b>		
Modern design and look with metal console and ergonomic control knobs. 4-way venting.	Metercase Model Accepts the Following Payment Systems: Coin Slide, Coin-Drop, Card Reader	Metercase Model Accepts the Following Payment Systems: Coin Slide, Coin-Drop, Card Reader
<b>DRUM VOLUME</b>	7.4 Cu. Ft.	7.4 Cu. Ft.
<b>MOTOR</b>	1/3 HP Single-Speed Motor with Built-In Overload Protector	1/3 HP Single-Speed Motor with Built-In Overload Protector
<b>ELECTRICAL REQUIREMENTS</b>	3-Wire Nominal 240/208 Volt, 60 Hz, A.C. Standard 30-Amp Breaker/Fuse Circuit per Dryer (Subject to Local Codes)	3-Wire, 120 Volt, 60 Hz, A.C. Standard 15-Amp Breaker/Fuse Circuit per Dryer (Subject to Local Codes)
<b>HEATER TYPE</b>	Electric	Gas*
<b>HEATER/BURNER RATING</b>	Heater Rated at 5600 Watts	22,000 BTU Natural Gas
<b>OPERATIONAL AMPERAGE</b>	Motor—4.0 AMPS, No Load Heater—23.33 AMPS @ 240 Volt—27.33 Total	Motor—4.0 AMPS, No Load
<b>SHIPPING WEIGHT (EST.)</b>	154 lbs. Crated, 140 lbs. Uncrated	154 lbs. Crated, 140 lbs. Uncrated
<b>DIMENSIONS</b>		
Cabinet Width—in. (mm)	27 (686)	27 (686)
Cabinet Depth—in. (mm)	29.25 (743)	29.25 (743)
Cabinet Height—in. (mm) at Metercase Top	43.25 (1099)	43.25 (1099)

\*Burner orifices are available for manufactured, natural, mixed and LP gas with varying BTU ratings.



Dimensions are for planning purposes only. For complete information, see installation instructions packed with product.

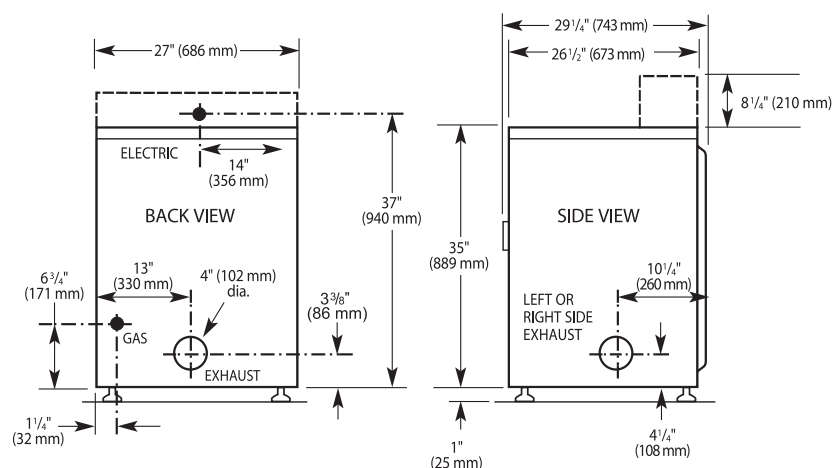

### Exhaust Information

All dryers require the equivalent of a 4-inch diameter exhaust duct. Rigid metal duct is recommended. Failure to properly exhaust the dryer will result in improper operation.

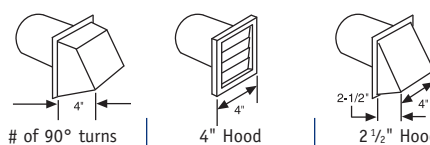

# of 90° turns	4" Hood	2 1/2" Hood
Maximum length of 4" diameter rigid metal duct		
0	64 Ft.	58 Ft.
1	54 Ft.	48 Ft.
2	44 Ft.	38 Ft.
3	35 Ft.	29 Ft.
4	27 Ft.	21 Ft.
Maximum length of 4" diameter flexible metal duct		
0	36 Ft.	28 Ft.
1	31 Ft.	23 Ft.
2	27 Ft.	19 Ft.
3	25 Ft.	17 Ft.
4	23 Ft.	15 Ft.



### 3-YEAR LIMITED PARTS ONLY WARRANTY

For a period of time from the date of original purchase through the time listed above, the designated parts that fail in normal commercial use will be repaired or replaced free of charge for the part itself, with the owner paying all other costs, including labor, transportation and customs duty. Chemical damage is excluded from all warranty coverage. See complete warranty for details.

To Locate a Distributor Near You, Please Visit [www.whirlpoolcommerciallaundry.com/distributor](http://www.whirlpoolcommerciallaundry.com/distributor), or call 1-800-662-3587.

TORX is a registered Trademark of Textron Industries, Inc.

®/™ © 2013 Whirlpool. All rights reserved.

Whirlpool Corporation • Benton Harbor, Michigan 49022 U.S.A.