

▲WARNING: DISCONNECT APPLIANCE FROM ELECTRICAL SUPPLY BEFORE SERVICING.

SPECIFICATIONS

Electrical Supply (Under Load) - 60 Hz - 120 VAC \pm 10%

Supply Water Flow Rate - Must fill 1 quart container in 14 seconds with a 88 sec. fill (yellow valve).

Supply Water Temperature - 120°F to 150°F (49°C - 66°C)

Before starting dishwasher, run water at sink faucet until hot.

Thermostat (*some models*) - Contacts will close at 127°F \pm 5°F (53°C \pm 3°C). The sump water should heat to approximately 145° \pm 5°F (63°C \pm 3°C) with outer door in place.

Water Charge - 6 to 7 quarts (5.7 - 6.6 liters)

Spray Arm Rotation - 20 to 40 RPM

MOTOR INSTALLATION

Installation of motor to pump housing requires centering of motor shaft using service tool 5300803923 (*see illustration below*). Service tool is not packed with motor and must be ordered separately. Failure to center motor shaft may result in seal leaks and noisy operation. The centering tool is also used to install the seal.

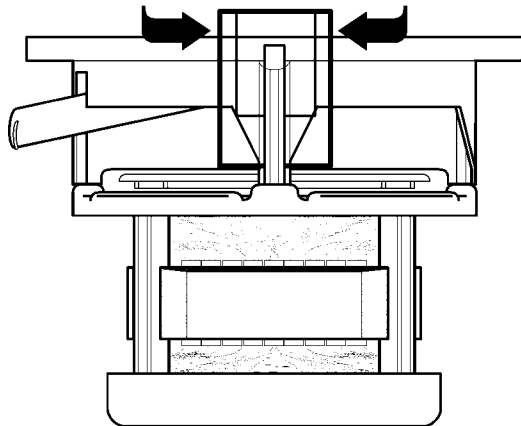

COMMON CAUSES OF LEAKS

Door Area

- Tub gasket not firmly seated in corners.
- Tub shifted out of square during installation, causing leak in upper corners.
- Vent baffle not sealing properly against tub dam.
- Spray arm split, open crimp seams, or binding.
- Sudsing, which may be caused by:
 - *use of non-dishwasher detergent,*
 - *low water temperature (should be 140°F [60°C]),*
 - *inferior dishwasher detergent, not suppressing foam.*

Lower pump housing and motor area

- Motor shaft seal damaged or defective.
- Pump housing gasket not seated, screws not tight.

- Pump housing cracked.
- Hose connections loose.

Float area

- Dirty float tube causing float to stick.

Other areas

- Water temperature over 160°F (71°C) causing excessive condensation.

WASHABILITY COMPLAINTS

Dishes not clean

- Supply water temperature 140°F (60°C) for best results.
- Improper loading.
- Detergent is old, caked or lumpy.
- Detergent cup is not releasing or opening too soon.
- Low water charge due to low water pressure or clogged water valve.
- Hard water film (water with 12 grains or more hardness may require a water softener). Use more detergent.
- Etching (usually on glassware) - caused by a combination of soft water (0 - 4 grains), water temperature over 160°F (71°C), or too much detergent.

Dishes not dry

- Dishes not loaded to permit proper draining.
- Wetting agent not being used in models equipped with automatic wetting agent dispenser.
- Supply water temperature under 140°F (60°C). Purge cold water out of hot water faucet.
- Low voltage supply.
- Cool Dry is being selected when Hot Dry is needed.
- Defective heating element - a good element has a resistance of 23 to 25 ohms.

Staining

- Coffee or tea - to remove, place items in dishwasher and add 1 tablespoon of chlorine bleach to the detergent. Run machine through the cycle. **DO NOT LOAD SILVERWARE OR METAL ITEMS.**
- Red or brown stains on the tub or dishes may be caused by as little as 1 PPM of iron in the water supply. To remove iron stains from the tub:
 1. *Remove all dishware and silverware.*
 2. *Pour 8 oz. (224 ml) of resin bed cleaner, used in water softeners, into bottom of tub.*
 3. *Place detergent in covered cup.*
 4. *Allow dishwasher to run through complete normal cycle uninterrupted. The dry cycle may be omitted.*
- Hard water film or lime deposit build-up - pour 2 cups of vinegar into empty dishwasher and run through Rinse/ Hold cycle. Filmed glasses/dishware may also be cleaned in this manner, but not silverware. Some commercial products, such as "Lime-A-Way", may be available in your area. **▲Caution:** Carefully follow instructions on product container.

TIMER SWITCHING FUNCTIONS IN MINUTES

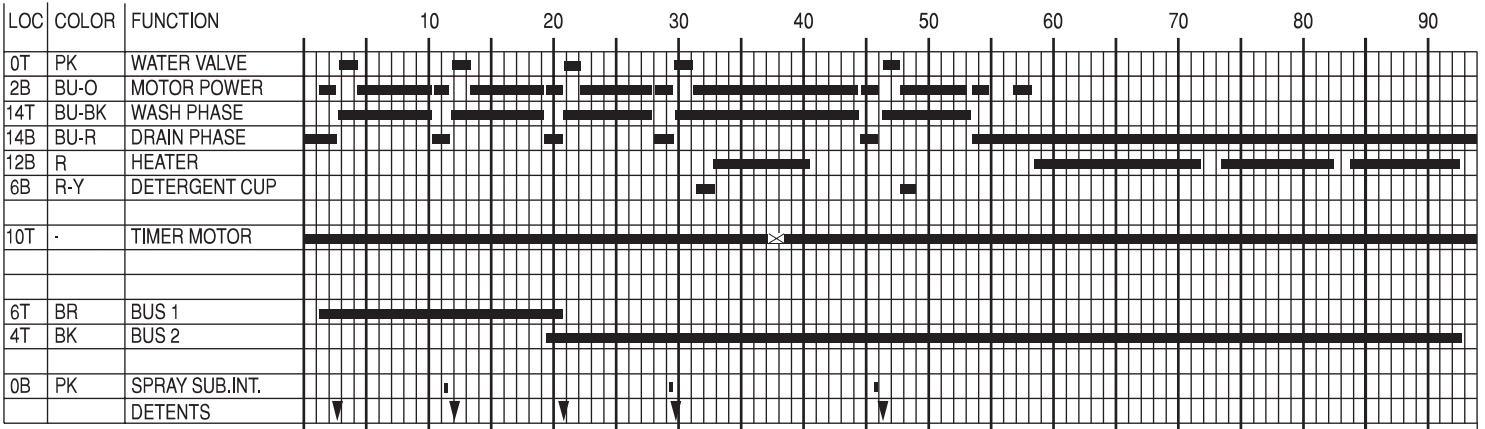

O=OPEN
X=CLOSED
E=EITHER

SWITCH			CYCLE
F	E	G	B
			X
			X
			O
			O
			O
E	E	O	
X	O	E	
O	X	X	

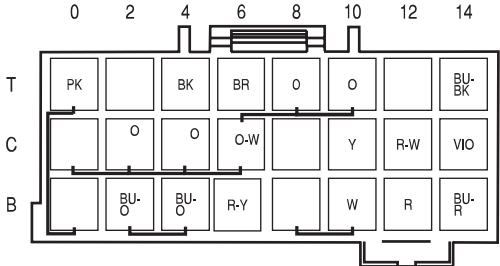
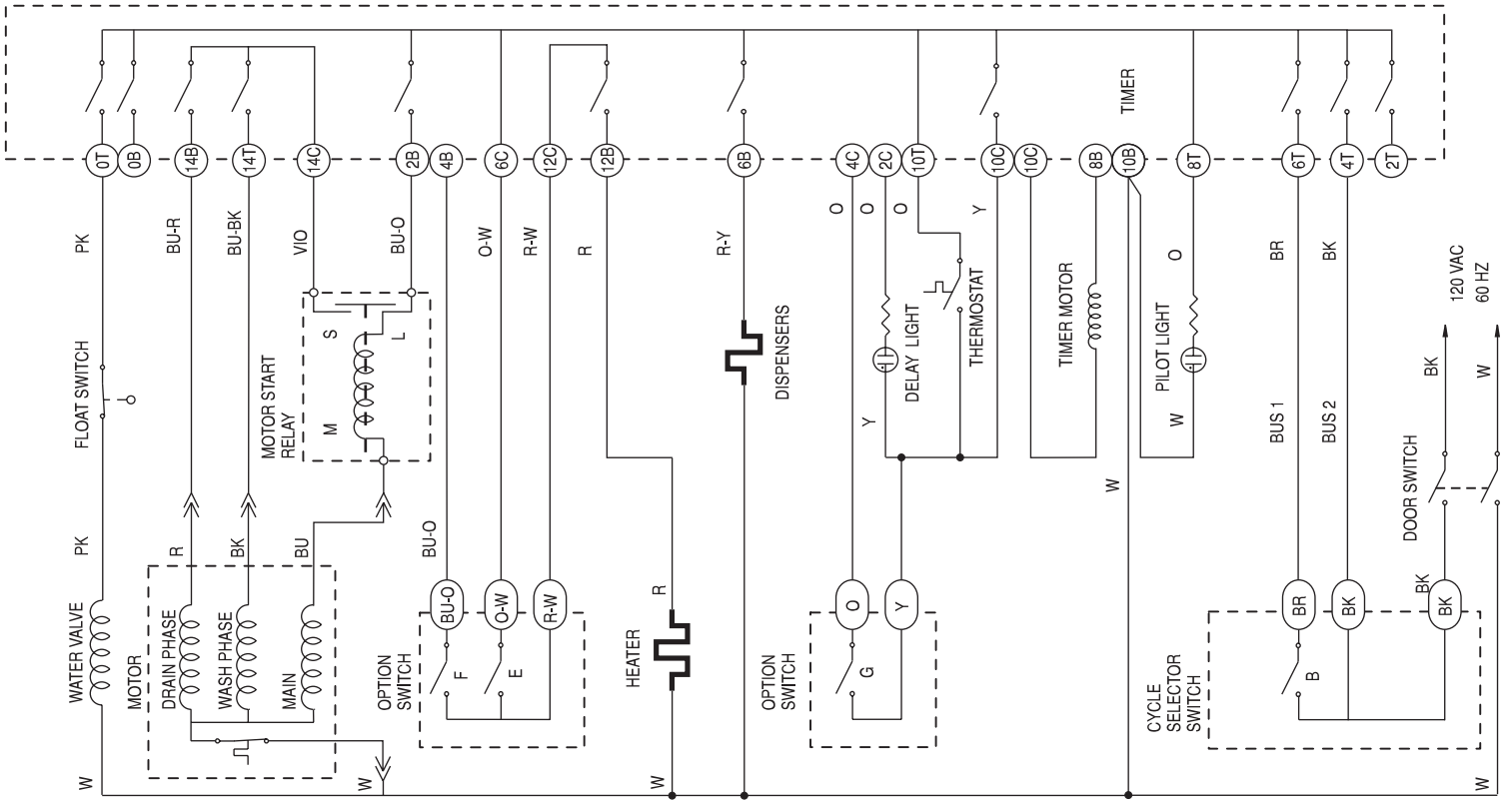
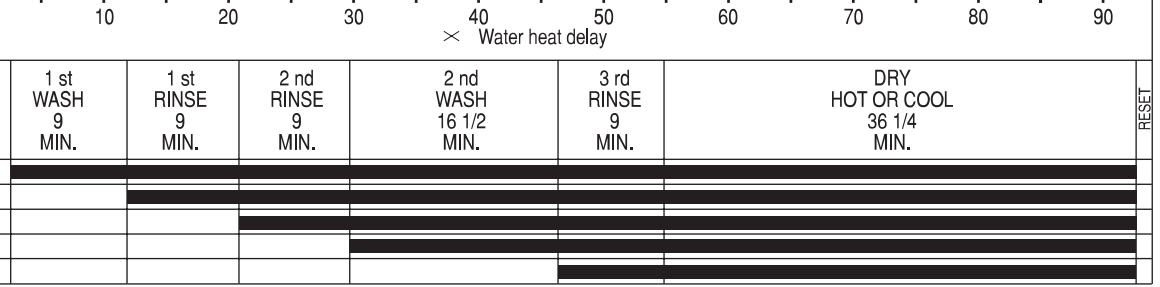

Color Code					
R:	Red	BK-Y:	Black/Yellow	VIO:	Violet
R-Y:	Red/Yellow	BK-W:	Black/White	PK:	Pink
R-W:	Red/White	O:	Orange	BU:	Blue
Y:	Yellow	O-W:	Orange/White	BU-R:	Blue/Red
W:	White	BR:	Brown	BU-BK:	Blue/Black
BU-O:	Blue/Orange	PK-W:	Pink/White	PK-BK:	Pink/Black
BK:	Black	BR-W:	Brown/White		