

OPERATOR'S MANUAL

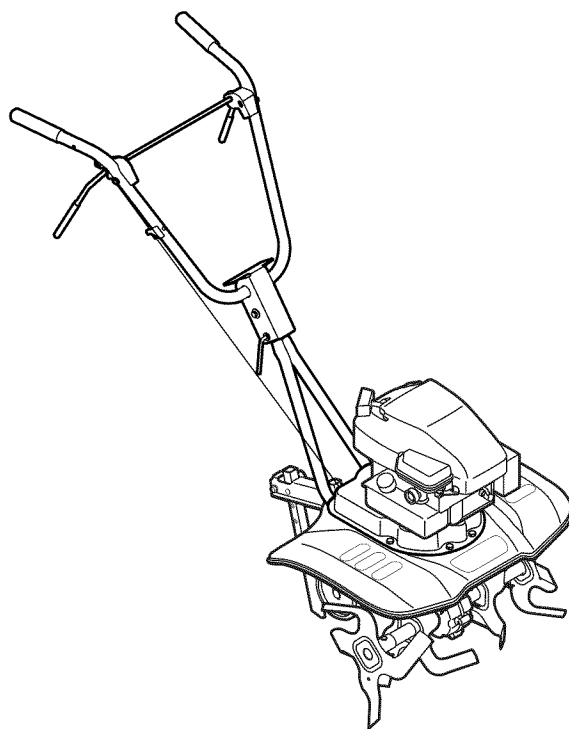

World Tiller — Series 210-240

⚠ WARNING

**READ AND FOLLOW ALL SAFETY RULES AND INSTRUCTIONS IN THIS MANUAL
BEFORE ATTEMPTING TO OPERATE THIS MACHINE.
FAILURE TO COMPLY WITH THESE INSTRUCTIONS MAY RESULT IN PERSONAL INJURY.**

MTD LLC, P.O. BOX 361131 CLEVELAND, OHIO 44136-0019

Thank You

Thank you for purchasing an MTD Garden Tiller. It was carefully engineered to provide excellent performance when properly operated and maintained.

Please read this entire manual prior to operating the equipment. It instructs you how to safely and easily set up, operate and maintain your machine. Please be sure that you, and any other persons who will operate the machine, carefully follow the recommended safety practices at all times. Failure to do so could result in personal injury or property damage.

All information in this manual is relative to the most recent product information available at the time of printing. Review this manual frequently to familiarize yourself with the machine, its features and operation. Please be aware that this Operator's Manual may cover a range of product specifications for various models. Characteristics and features discussed and/or illustrated in this manual may not be applicable to all models. We reserve the right to change product specifications, designs and equipment without notice and without incurring obligation.

If you have any problems or questions concerning the machine, phone your local authorized MTD service dealer or contact us directly. MTD's Customer Support telephone numbers, website address and mailing address can be found on this page. We want to ensure your complete satisfaction at all times.

Throughout this manual, all references to *right* and *left* side of the machine are observed from the operating position

The engine manufacturer is responsible for all engine-related issues with regards to performance, power-rating, specifications, warranty and service. Please refer to the engine manufacturer's Owner's/Operator's Manual, packed separately with your machine, for more information.

Table of Contents

Safe Operation Practices	3	Maintenance & Adjustment.....	12
Assembly & Set-Up	7	Service	14
Controls.....	9	Troubleshooting.....	15
Operation.....	10	Illustrated Parts List	16

Record Product Information

Before setting up and operating your new equipment, please locate the model plate on the equipment and record the information in the provided area to the right. You can locate the model plate by standing at the operator's position and looking down at the rear of the tine shield near the handle. This information will be necessary, should you seek technical support via our web site, Customer Support Department, or with a local authorized service dealer.

MODEL NUMBER

--	--	--	--	--	--	--	--	--	--	--	--

SERIAL NUMBER

--	--	--	--	--	--	--	--	--	--	--	--

Customer Support

Please do NOT return the machine to the retailer or dealer without first contacting our Customer Support Department.

If you have difficulty assembling this product or have any questions regarding the controls, operation, or maintenance of this machine, you can seek help from the experts. Choose from the options below:

- ◇ Visit us on the web at www.mtdproducts.com
- ◇ Call a Customer Support Representative at (800) 800-7310 or (330) 220-4683
- ◇ Write to MTD LLC • P.O. Box 361131 • Cleveland, OH • 44136-0019



WARNING! This symbol points out important safety instructions which, if not followed, could endanger the personal safety and/or property of yourself and others. Read and follow all instructions in this manual before attempting to operate this machine. Failure to comply with these instructions may result in personal injury.

When you see this symbol. **HEED ITS WARNING!**

CALIFORNIA PROPOSITION 65



WARNING! Engine Exhaust, some of its constituents, and certain vehicle components contain or emit chemicals known to State of California to cause cancer and birth defects or other reproductive harm.



WARNING! Battery posts, terminals, and related accessories contain lead and lead compounds, chemicals known to the State of California to cause cancer and reproductive harm. *Wash hands after handling*



DANGER! This machine was built to be operated according to the safe operation practices in this manual. As with any type of power equipment, carelessness or error on the part of the operator can result in serious injury. This machine is capable of amputating fingers, hands, toes and feet. Failure to observe the following safety instructions could result in serious injury or death.

Training

1. Read, understand, and follow all instructions on the machine and in the manual(s) before attempting to assemble and operate. Keep this manual in a safe place for future and regular reference and for ordering replacement parts.
2. Be familiar with all controls and their proper operation. Know how to stop the machine and disengage them quickly.
3. Never allow children under 14 years of age to operate this machine. Children 14 and over should read and understand the instructions and safe operation practices in this manual and on the machine and be trained and supervised by an adult.
4. Never allow adults to operate this machine without proper instruction.
5. Keep the area of operation clear of all persons, particularly small children and pets. Stop machine if anyone enters the area.
2. Wear sturdy, rough-soled work shoes and close fitting slacks and shirt. Loose fitting clothes or jewelry can be caught in moving parts. Never operate this machine in bare feet or sandals.
3. Disengage clutch levers and shift (if provided) into neutral ("N") before starting the engine.
4. Never leave this machine unattended with the engine running.
5. Never attempt to make any adjustments while engine is running, except where specifically recommended in the operator's manual.

Safe Handling of Gasoline:

To avoid personal injury or property damage use extreme care in handling gasoline. Gasoline is extremely flammable and the vapors are explosive. Serious personal injury can occur when gasoline is spilled on yourself or your clothes which can ignite. Wash your skin and change clothes immediately.

- a. Use only an approved gasoline container.
- b. Never fill containers inside a vehicle or on a truck or trailer bed with a plastic liner. Always place containers on the ground away from your vehicle before filling.

Preparation

1. Thoroughly inspect the area where the equipment is to be used. Remove all stones, sticks, wire, and other foreign objects which could be tripped over and cause personal injury.

- c. When practical, remove gas-powered equipment from the truck or trailer and refuel it on the ground. If this is not possible, then refuel such equipment on a trailer with a portable container, rather than from a gasoline dispenser nozzle.
 - d. Keep the nozzle in contact with the rim of the fuel tank or container opening at all times until fueling is complete. Do not use a nozzle lock-open device.
 - e. Extinguish all cigarettes, cigars, pipes and other sources of ignition.
 - f. Never fuel machine indoors.
 - g. Never remove gas cap or add fuel while the engine is hot or running. Allow engine to cool at least two minutes before refueling.
 - h. Never over fill fuel tank. Fill tank to no more than ½ inch below bottom of filler neck to allow space for fuel expansion.
 - i. Replace gasoline cap and tighten securely.
 - j. If gasoline is spilled, wipe it off the engine and equipment. Move unit to another area. Wait 5 minutes before starting the engine.
 - k. To reduce fire hazards, keep machine free of grass, leaves, or other debris build-up. Clean up oil or fuel spillage and remove any fuel soaked debris.
 - l. Never store the machine or fuel container inside where there is an open flame, spark or pilot light as on a water heater, space heater, furnace, clothes dryer or other gas appliances.
- 11. After striking a foreign object, stop the engine, disconnect the spark plug wire and ground against the engine. Thoroughly inspect the machine for any damage. Repair the damage before starting and operating.
 - 12. Disengage all clutch levers (if fitted) and stop engine before you leave the operating position (behind the handles). Wait until the tines come to a complete stop before unclogging the tines, making any adjustments, or inspections.
 - 13. Never run an engine indoors or in a poorly ventilated area. Engine exhaust contains carbon monoxide, an odorless and deadly gas.
 - 14. Muffler and engine become hot and can cause a burn. Do not touch.
 - 15. Use caution when tilling near fences, buildings and underground utilities. Rotating tines can cause property damage or personal injury.
 - 16. Do not overload machine capacity by attempting to till soil too deep at too fast of a rate.
 - 17. If the machine should start making an unusual noise or vibration, stop the engine, disconnect the spark plug wire and ground it against the engine. Inspect thoroughly for damage. Repair any damage before starting and operating.
 - 18. Keep all shields, guards, and safety devices in place and operating properly.
 - 19. Never pick up or carry machine while the engine is running.
 - 20. Use only attachments and accessories approved by the manufacturer. Failure to do so can result in personal injury.
 - 21. If situations occur which are not covered in this manual, use care and good judgement. Contact Customer Support for assistance and the name of you nearest servicing dealer..

Operation

1. Do not put hands or feet near rotating parts. Contact with the rotating parts can amputate hands and feet.
2. Do not operate machine while under the influence of alcohol or drugs.
3. Never operate this machine without good visibility or light. Always be sure of your footing and keep a firm hold on the handles.
4. Keep bystanders away from the machine while it is in operation. Stop the machine if anyone enters the area.
5. Be careful when tilling in hard ground. The tines may catch in the ground and propel the tiller forward. If this occurs, let go of the handle bars and do not restrain the machine.
6. Exercise extreme caution when operating on or crossing gravel surfaces. Stay alert for hidden hazards or traffic. Do not carry passengers.
7. Never operate the machine at high transport speeds on hard or slippery surfaces.
8. Exercise caution to avoid slipping or falling.
9. Look down and behind and use care when in reverse or pulling machine towards you.
10. Start the engine according to the instructions found in this manual and keep feet well away from the tines at all times.

Maintenance & Storage

1. Keep machine, attachments and accessories in safe working order.
2. Allow a machine to cool at least five minutes before storing. Never tamper with safety devices. Check their proper operation regularly.
3. Check bolts and screws for proper tightness at frequent intervals to keep the machine in safe working condition. Also, visually inspect machine for any damage.
4. Before cleaning, repairing, or inspecting, stop the engine and make certain the tines and all moving parts have stopped. Disconnect the spark plug wire and ground it against the engine to prevent unintended starting.
5. Do not change the engine governor settings or over-speed the engine. The governor controls the maximum safe operating speed of engine.
6. Maintain or replace safety and instruction labels, as necessary.
7. Follow this manual for safe loading, unloading, transporting, and storage of this machine.
8. Always refer to the operator's manual for important details if the machine is to be stored for an extended period.

9. If the fuel tank has to be drained, do this outdoors.
10. Observe proper disposal laws and regulations for gas, oil, etc. to protect the environment.
11. According to the Consumer Products Safety Commission (CPSC) and the U.S. Environmental Protection Agency (EPA), this product has an *Average Useful Life* of seven (7) years, or 130 hours of operation. At the end of the *Average Useful Life* have the machine inspected annually by an authorized service dealer to ensure that all mechanical and safety systems are working properly and not worn excessively. Failure to do so can result in accidents, injuries or death.

Notice Regarding Emissions

Engines which are certified to comply with California and federal EPA emission regulations for SORE (Small Off Road Equipment) are certified to operate on regular unleaded gasoline, and may include the following emission control systems: Engine Modification (EM), Oxidizing Catalyst (OC), Secondary Air Injection (SAI) and Three Way Catalyst (TWC) if so equipped.

Spark Arrestor









WARNING! This machine is equipped with an internal combustion engine and should not be used on or near any unimproved forest-covered, brushcovered or grass-covered land unless the engine's exhaust system is equipped with a spark arrester meeting applicable local or state laws (if any).

If a spark arrester is used, it should be maintained in effective working order by the operator. In the State of California the above is required by law (Section 4442 of the California Public Resources Code). Other states may have similar laws. Federal laws apply on federal lands.

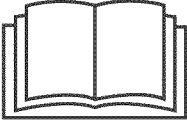
A spark arrester for the muffler is available through your nearest engine authorized service dealer or contact the service department, P.O. Box 361131 Cleveland, Ohio 44136-0019.

Safety Symbols

This page depicts and describes safety symbols that may appear on this product. Read, understand, and follow all instructions on the machine before attempting to assemble and operate.

Symbol	Description
	READ THE OPERATOR'S MANUAL(S) Read, understand, and follow all instructions in the manual(s) before attempting to assemble and operate.
	WARNING— ROTATING TINES Do not put hands or feet near rotating parts. Contact with the rotating parts can amputate hands and feet.
	WARNING— ROTATING TINES Do not put hands or feet near rotating parts. Contact with the rotating parts can amputate hands and feet.
	WARNING— GASOLINE IS FLAMMABLE Allow the engine to cool at least two minutes before refueling.
	WARNING— CARBON MONOXIDE Never run an engine indoors or in a poorly ventilated area. Engine exhaust contains carbon monoxide, an odorless and deadly gas.
	WARNING— HOT SURFACE Engine parts, especially the muffler, become extremely hot during operation. Allow engine and muffler to cool before touching.



WARNING! Your Responsibility—Restrict the use of this power machine to persons who read, understand and follow the warnings and instructions in this manual and on the machine.

SAVE THESE INSTRUCTIONS!

Contents of Carton

- One Tiller
- One 20 oz. bottle SAE 30W oil
- One Tiller Operator's Manual
- One Engine Operator's Manual

NOTE: The tiller is shipped without gasoline or oil in the engine. Fill up gasoline and oil as instructed in the accompanying engine manual before operating your machine.

Assembly

Handle

1. Remove the handle crank, bolt, washer, retainer bracket and the flange lock nuts from the lower handle. See Fig. 3-1.

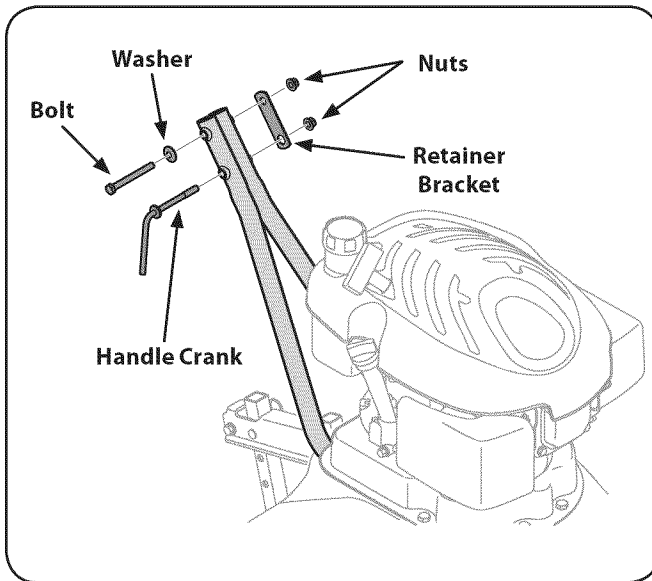

Figure 3-1

2. Position the upper handle onto the lower handle, Step A in Fig. 3-2. Align the holes on the lower handle with the holes on the upper handle.

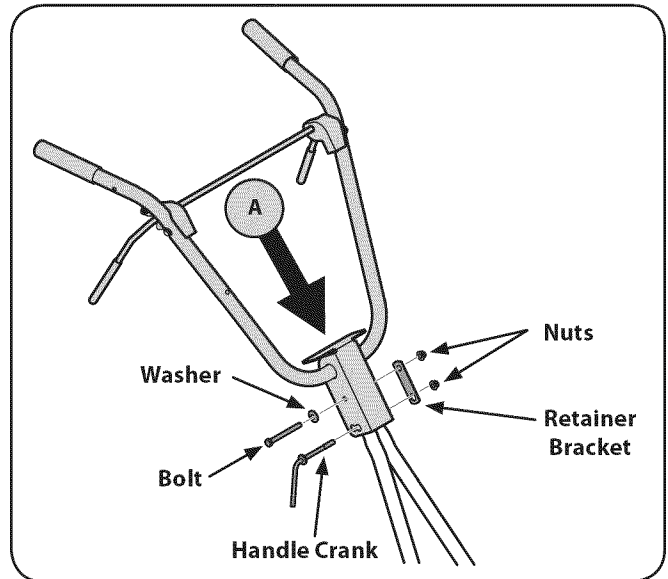

Figure 3-2

3. Insert bolt, washer, and handle crank through the holes in the handle and secure with retainer bracket and nuts. See Fig. 3-2.

4. Insert the clutch cable handle fitting into the hole on the right side of the upper handle. See Fig. 3-3.

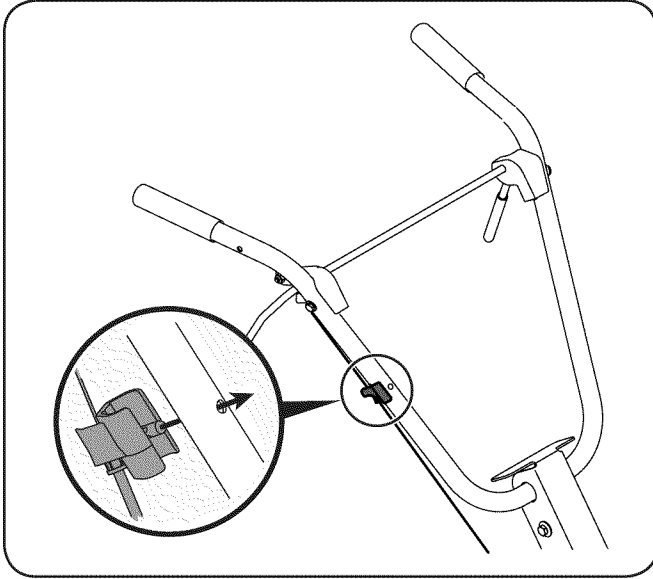

Figure 3-3

5. Insert the Z-fitting on the clutch cable into the hole on the tine clutch control. Hook the "Z" end into the opening from the outside to the inside as shown in Fig. 3-4.

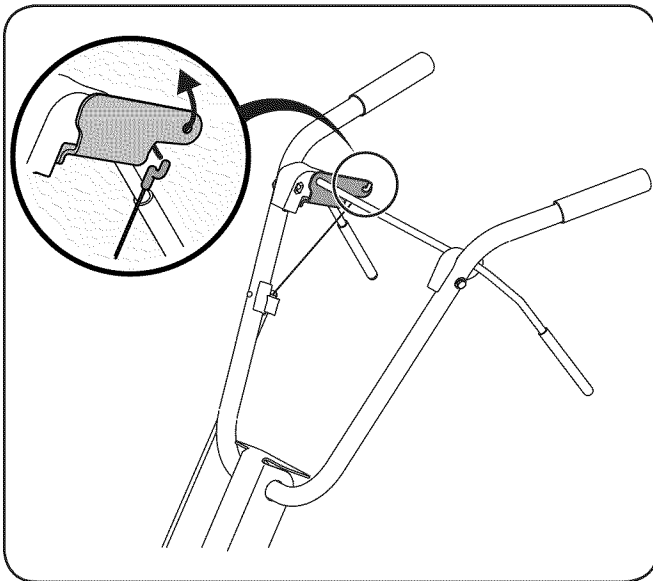

Figure 3-4

Set-Up

Gas & Oil Fill-Up

Service the engine with gasoline and oil as instructed in the separate engine manual packed with your tiller. Read the instructions carefully.



WARNING! Use extreme care when handling gasoline. Gasoline is extremely flammable and the vapors are explosive. Never fuel machine indoors or while the engine is hot or running.

Adjustments

Wheels

The tiller is shipped with the wheel adjusted such that the unit sits level. Before tilling, the wheel must be raised. To do this, remove the clevis and cotter pins, raise the wheel to the desired position, then reattach pins to secure, Figure 3-5. For transporting the tiller, reverse the steps to lower the wheel.

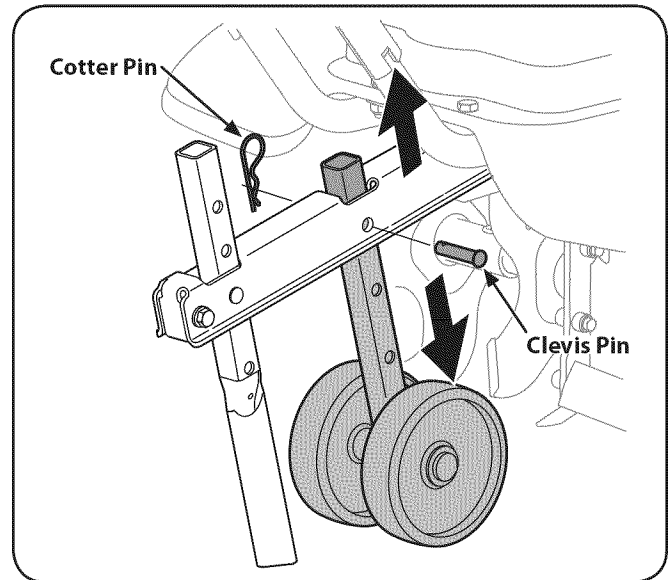

Figure 3-5

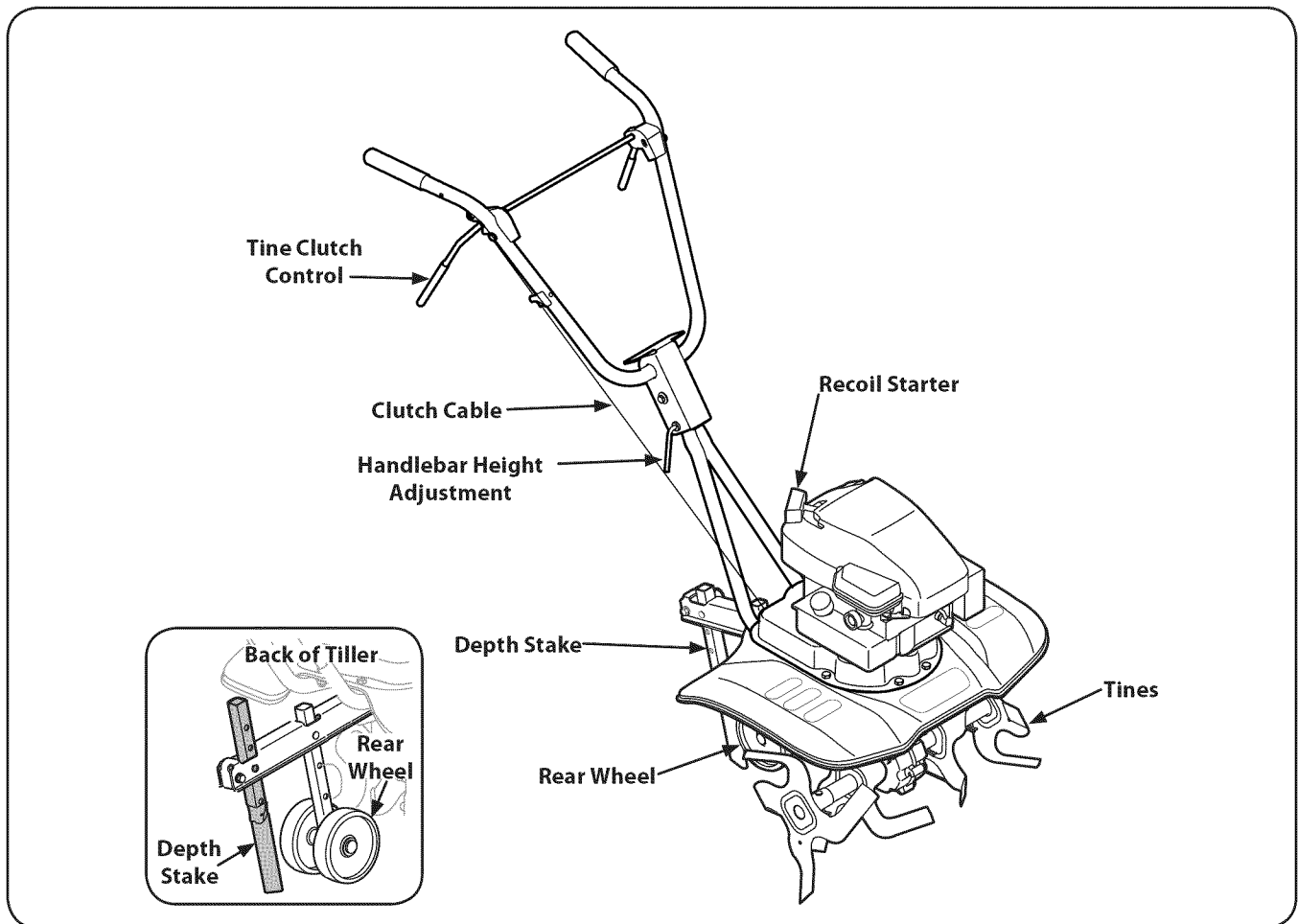

Figure 4-1

Tine Clutch Control

The clutch control lever is located on the upper handle. Squeezing the lever against the handle engages the tine drive. Release the lever to stop the tines from turning.

Handlebar Height Adjustment

The handlebar height is adjustable to three different settings. In general, adjust the handlebars so they are at waist level when the tines are 3-4" in the ground.

Recoil Starter

The recoil starter is located on the engine and is used to manually start the engine.

Depth Stake

The depth stake acts as a brake for the tiller and controls the depth and speed at which the machine will operate.

Rear Wheel with Depth Stake

The rear wheel can be raised and lowered for transport and storage. Refer to the Maintenance & Adjustments Section for instructions on depth stake adjustment and the Assembly & Set-Up Section for instructions on wheel adjustment.

Engine Controls

Refer to the engine manual for additional information and functions of the engine controls.

Throttle Control (If Equipped)

The throttle control lever is located on the engine. It controls the engine's speed and stops the engine.

Primer

The primer, located on the engine, is used to pump gas into the carburetor and aid in starting the engine. Use it to start a cold engine, but do not use it to restart a warm engine after a short shutdown.



WARNING! Read, understand, and follow all instructions and warnings posted on the machine and in this manual before operating.



WARNING! Be sure no one other than the operator is standing near the tiller while starting the engine or operating the unit. Never run the engine indoors or in enclosed, poorly ventilated areas. Engine exhaust contains carbon monoxide, an odorless and deadly gas. Keep hands, feet, hair and loose clothing away from any moving parts on the engine and the tiller.

Starting Engine



WARNING! Be sure no one is standing in front of the tiller while the engine is running or being started.

Refer to the engine manual for instructions.

1. Attach the spark plug wire to the spark plug. Make sure the metal cap on the end of the spark plug is fastened securely over the metal tip on the spark plug.
2. Make sure that the tine clutch control is disengaged.
3. Place the throttle control (if equipped) in the FAST position.
4. For first time start-up, firmly press engine primer five (5) times. For all future starts, press three (3) times. Wait about two seconds between each press.
5. Place your left hand on the gas tank. Grasp the recoil starter and pull the rope out slowly until the engine reaches the beginning of its compression cycle (rope will pull slightly harder at this point).
6. Pull the rope with a rapid, continuous, full arm stroke. Keep a firm grip on the handle. Let the rope rewind slowly. Do not let the recoil starter snap back against the engine. Repeat until the engine starts.

Stopping Engine

1. Move the throttle control lever (if equipped) to STOP or OFF position. Refer to the engine manual for instructions on stopping the engine.
2. Disconnect the spark plug wire from the spark plug and ground against the engine.

Using Your Tiller

Your tiller is designed for seed bed preparation, cultivating, furrowing, and mulching.

Controlling Tilling and Depth Speed

By increasing the depth of the depth stake, the forward speed of the machine is reduced and the working depth is increased. When the depth stake is raised, the working depth of the machine is reduced and the forward speed is increased.

The working depth of the machine may be predetermined by setting the depth stake so that the wheels are about four inches from the ground when the tines and depth stake are resting on the ground. This setting will permit a working depth of about four inches. When presetting the working depth, the handles should be adjusted so the hand grips are a little above the waist. The tiller will be lower when the tines and depth stake penetrate the ground.

For tilling, the depth stake must be lowered and the wheel must be raised. See Fig. 5-1.

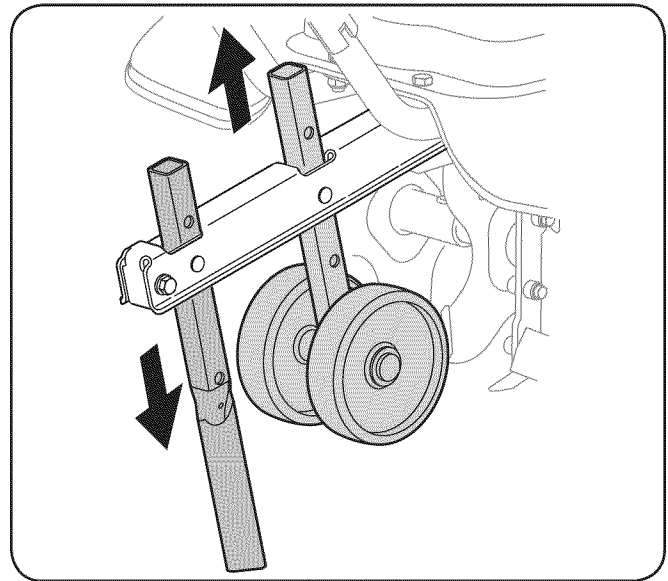

Figure 5-1

When tilling, leave approximately eight inches of untilled soil between the first and second tilling paths, then make the third path between the first and second. See Fig. 5-2.

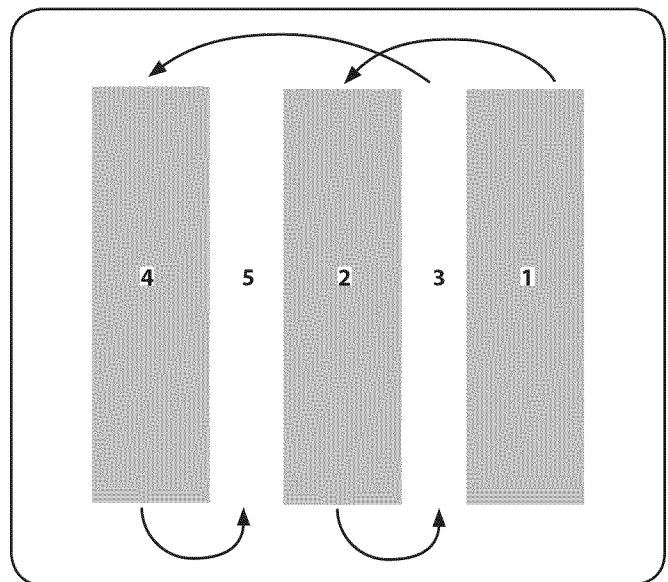

Figure 5-2

In some soils, the desired depth is obtained the first time over the garden. In other soils, the desired depth is obtained by going over the garden two or three times. Passes should be made across the length and width of the garden alternately. Rocks which are turned up should be removed from the garden area.

Handle Pressure

Further control of tilling depth and travel speed can be obtained by variation of pressure on the handles. A downward pressure on the handles will reduce the working depth and increase the forward speed. An upward pressure on the handles will increase the working depth and reduce the forward speed. The type of soil and working conditions will determine the actual setting of the depth stake and the handle pressure required.

Cultivating

For cultivating, a two to three inch depth is desirable. With the outer tines installed, the working width of the machine is 22 or 24 inches.

For cultivation, the tine width can be reduced to 13 inches by removing the outer tines, refer to the Adjustment Section. When laying out plant rows, be sure to allow enough width to permit cultivation between the rows. In growing corn or similar crops, check-row planting will permit cross cultivation and practically eliminate hand hoeing, Fig. 5-3.

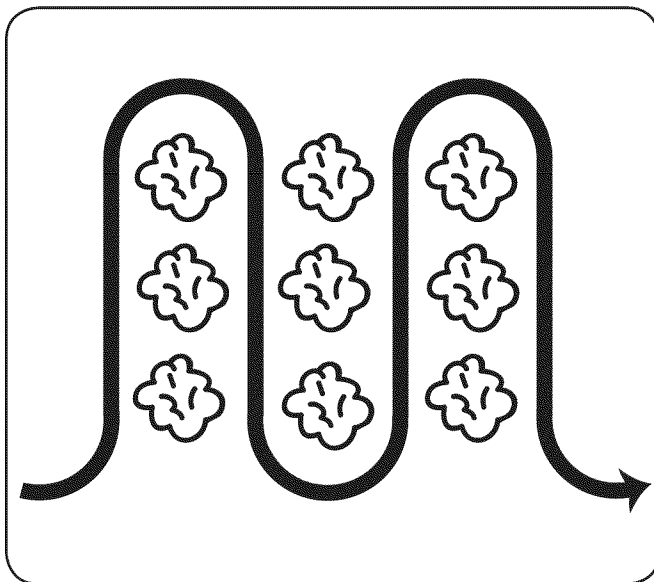

Figure 5-3

The tiller has many uses other than tilling and cultivating a garden. One of these is the preparation of lawn area for seeding. The tiller will prepare a deep seed bed which will be free of hard untilled spots, allowing a better stand of grass to grow. The tiller is very useful for loosening hard soil for excavation with a shovel; No tedious handwork will be necessary. Your tiller may be used for mixing compost in the pile or for mixing it with the soil in your garden. This should be done after the soil has been broken to the full working depth. The compost should be worked in to a depth of six to seven inches. This may be done by working the length of the garden and then by making separate passes across its width. The addition of decayed organic matter will substantially increase the fertility of your garden.

For proper decaying action, fertilizer should be applied and worked in with the mulch materials. Breaking up leaves and straw and mixing it with several inches of soil allows proper aeration of the plant root system and retards the growth of weeds.

Transporting and Storing the Tiller

To transport the tiller, lower the wheel and move the depth stake to the highest position. See Fig. 5-4.

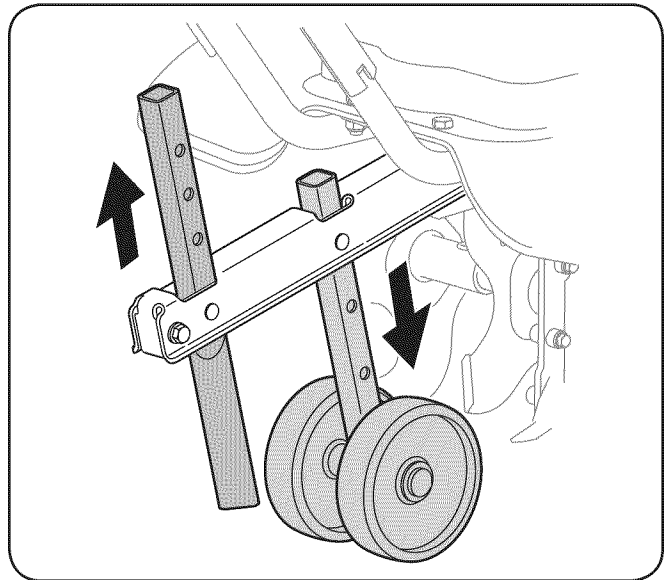

Figure 5-4

To store the tiller, lower the wheel and orient the depth stake so both are touching the ground. See Fig. 5-5.

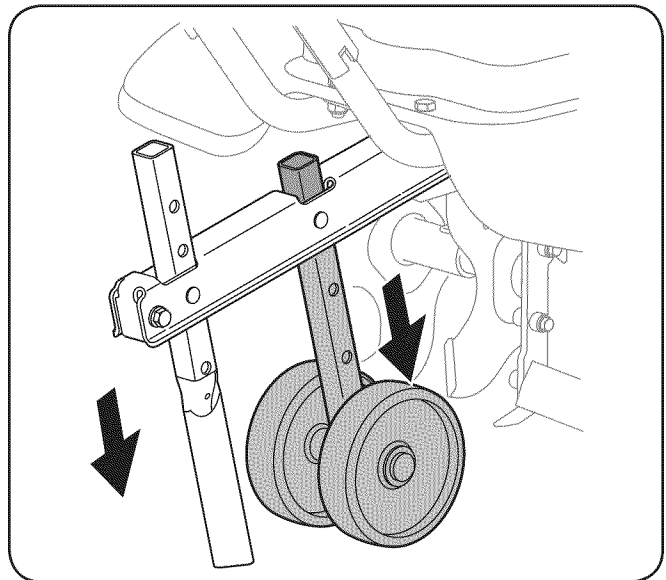

Figure 5-5



WARNING! Before inspecting, cleaning or servicing the tiller, shut off the engine and wait for all moving parts to come to a complete stop. Disconnect the spark plug. Failure to follow these instructions properly can result in serious personal injury or property damage.

Maintenance

Engine

Refer to the Engine Operator's Manual packaged with your machine for all engine maintenance.

Changing the Engine Oil

1. Run the engine for a few minutes to allow the oil in the crankcase to warm up. Warm oil will flow more freely and carry away more of the engine sediment which may have settled at the bottom of the crankcase. Use care to avoid burns from hot oil.
2. Set the tiller on its side with the air filter on the top side and the oil fill tube facing the ground.
3. Place an appropriate oil collection container with at least a 20 fluid ounce capacity to collect the used oil beneath the oil fill tube.
4. Remove the oil fill cap/dipstick from the oil fill tube.
5. After the oil has finished draining, stand the tiller back up.
6. Refill the engine with new oil. Refer to the Briggs & Stratton Owner's Manual for information regarding the volume and weight of engine oil.

Tines

Clean the underside of the tine shield after each use. The dirt washes off the tines easier if rinsed off immediately instead of after it dries. Always towel dry the tiller afterwards and apply a light coat of oil or silicone to prevent rusting or water damage.

NOTE: Never use a pressure washer to clean the tiller. Water can penetrate tight areas of the tiller and cause serious damage.

Air Filter

Service the air filter every 10 hours under normal operating conditions. Clean every hour under extremely dusty conditions. Poor engine performance and flooding usually indicates that the air filter should be serviced. To service the air filter refer to the separate Engine Operator's Manual.

Lubrication

Transmission

The transmission is pre-lubricated and sealed at the factory. It requires no maintenance. See an authorized service dealer for any service issues.

Tine Shafts

Remove tine assemblies and lubricate the tine shafts at least once a season.

Wheel Shaft

Remove wheel assembly and lubricate the axle shaft at least once a season.

Adjustments

Tine Width (Model Series 240)

The tilling width of the unit is 22 inches. Tilling width can increase to 24 inches by removing the clevis and cotter pins, sliding each outer tine out one inch, and securing in this position with the pins. For cultivation, reduce the tine width to 13 inches by removing the outer tines completely. See Fig. 6-1.

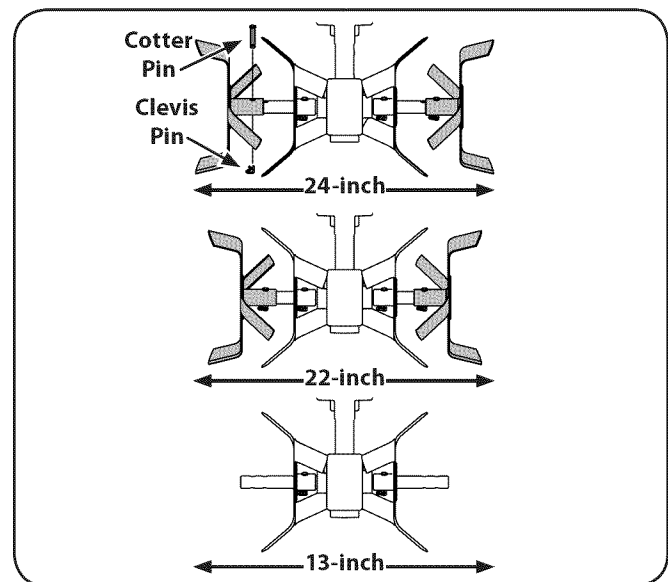

Figure 6-1

Depth Stake

The depth stake acts as a brake for the tiller and controls the depth and speed at which the machine will operate, Figure 6-2. Remove the clevis and cotter pins, raise or lower the depth stake, then reattach pins to secure.

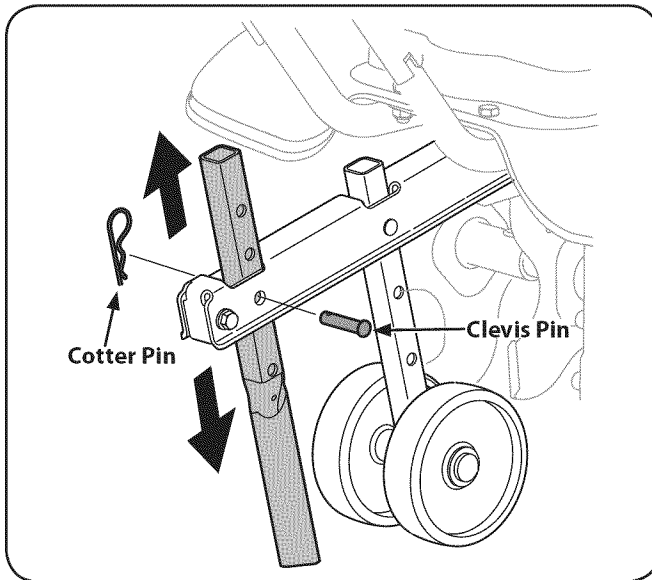

Figure 6-2

Off-Season Storage

If the tiller will not be used for a period longer than 30 days, the following steps should be taken to prepare the tiller for storage.

- Clean the exterior of the engine and the entire tiller thoroughly. Lubricate the tiller as described in the Lubrication instructions.
- We do not recommend the use of pressure washers to clean your tiller. They may cause damage to spindles, pulleys, bearings, or the engine. The use of pressure washers will result in shortened life and reduce serviceability.
- Refer to the engine manual for correct engine storage instructions.
- Wipe tines with oiled rag to prevent rust.
- Store tiller in a clean, dry area. Do not store next to corrosive materials, such as fertilizer.
- When storing any type of power equipment in an unventilated or metal storage shed, care should be taken to rustproof the equipment. Using a light oil or silicone, coat the equipment and especially any springs, bearings, and cables.

Belt Replacement

Your tiller has been engineered with a belt made of special material for longer life and better performance. Replace with a factory-approved OEM belt. See the retailer from which you purchased your tiller, an authorized MTD Service Dealer, or call 1-800-800-7310 for information regarding price and availability.

1. Remove the belt cover and engine by removing the six screws and lock nuts holding the engine and cover to the shield. See Fig. 7-1.

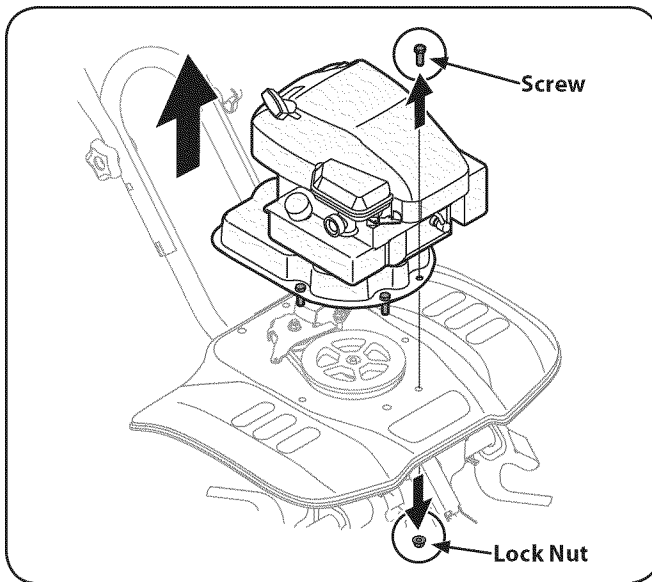

Figure 7-1

2. Loosen the lock nut shown in Fig. 7-2.

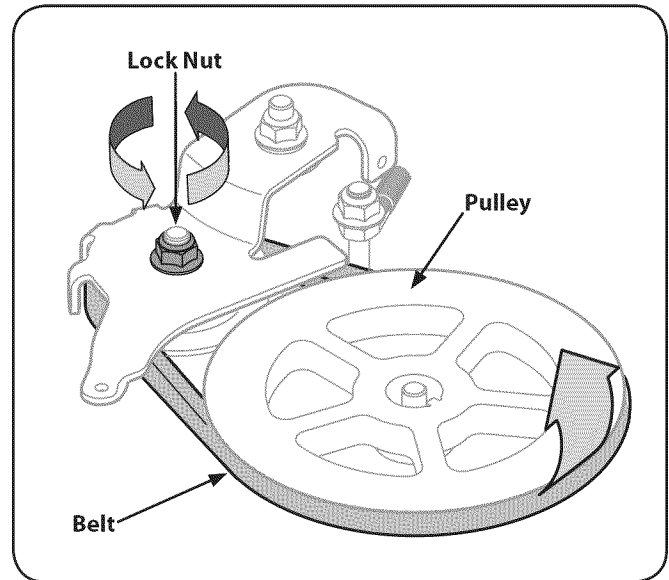
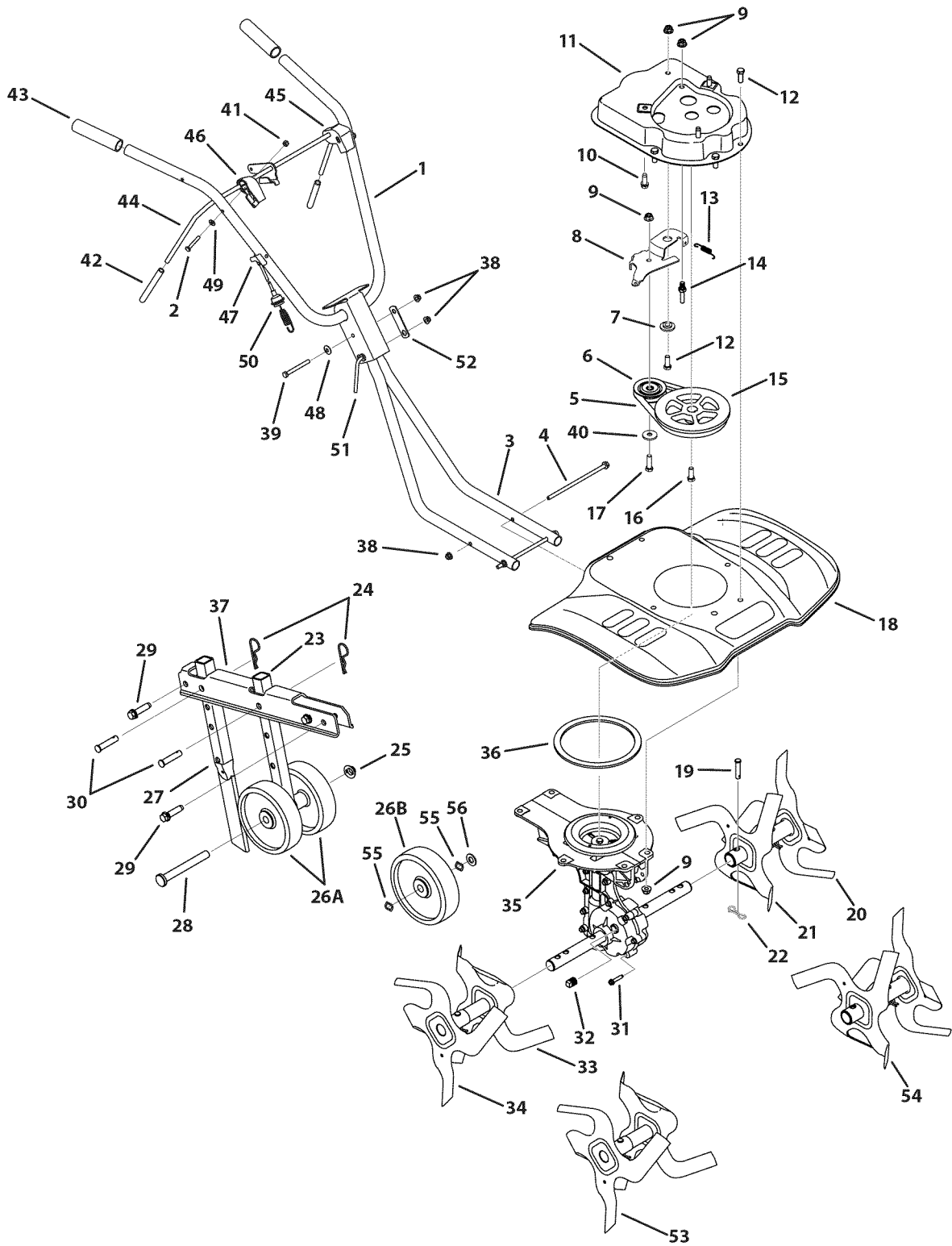

Figure 7-2

3. Unloop the belt from the pulleys. See Fig. 7-2.
4. Reassemble the new belt and tighten the lock nut.
5. Reattach belt cover and engine using the hardware removed earlier.

Problem	Cause	Remedy
Engine Fails to start	<ol style="list-style-type: none"> 1. Spark plug wire disconnected 2. Fuel tank empty or stale fuel 3. Throttle control lever (if equipped) not in correct starting position 4. Choke not in ON position 5. Blocked fuel line 6. Faulty spark plug 7. Engine flooding 	<ol style="list-style-type: none"> 1. Connect wire to spark plug 2. Fill tank with clean, fresh gasoline 3. Move throttle lever to start position 4. Move lever to ON position 5. Clean fuel line 6. Clean, adjust gap, or replace 7. Wait a few minutes to restart, but do not prime (if equipped)
Engine runs erratic	<ol style="list-style-type: none"> 1. Spark plug wire loose 2. Unit running on CHOKE 3. Blocked fuel line or stale fuel 4. Vent plugged 5. Water or dirt in fuel system 6. Dirty air cleaner 7. Carburetor out of adjustment 	<ol style="list-style-type: none"> 1. Connect and tighten spark plug wire 2. Move choke lever to OFF 3. Clean fuel line; fill tank with clean, fresh gasoline 4. Clear vent 5. Drain fuel tank. Refill with fresh fuel 6. Clean following engine manual 7. Refer to engine manual
Engine overheats	<ol style="list-style-type: none"> 1. Engine oil level low 2. Dirty air filter 3. Air flow restricted 4. Carburetor not adjusted properly 	<ol style="list-style-type: none"> 1. Fill crankcase with proper oil 2. Clean air cleaner 3. Remove blower housing and clean 4. Refer to engine manual
Tines do not engage	<ol style="list-style-type: none"> 1. Foreign object lodged in tines 2. Tine clevis pin(s) missing 3. Belt worn and/or stretched 4. Pulley and idler not in correct adjustment 	<ol style="list-style-type: none"> 1. Stop tiller completely, check and discard foreign object 2. Replace tine clevis pin(s) 3. Replace belt 4. Take unit to authorized service



Handle, Frame & Wheel Assembly

Ref.	Part Number	Description
1	649-04030-0638	Upper Handle
2	710-0136	Hex Head Cap Screw, ¼-20 x 1.75
3	649-04029-0638	Lower Handle
4	710-04398	Flange Screw, ⅝-18 x 7.5, GR5
5	954-04123	V-Belt
6	756-04163	Idler Pulley
7	748-04125	Shoulder Spacer
8	686-04080	Idler Bracket
9	712-04065	Flange Lock Nut, ⅜-16
10	710-0654A	Self Tapping Screw, ⅜-16 x 1.00
11	786-04303-0638	Belt Cover
12	710-0514	Hex Head Cap Screw, ⅜-16 x 1.00
13	732-0418	Extension Spring
14	738-04139	Stud, 33 x 1.5, ⅜-16
15	756-04217	Flywheel Pulley
16	710-0591	Hex Head Cap Screw, ⅜-24 x 1.00
17	710-0520	Hex Head Cap Screw, ⅜-16 x 1.55
18	786-04256-0638	Tine Shield 61 cm (model 240)
	786-04259-0638	Tine Shield 40 cm (model 210)
19	911-0415	Clevis Pin
20	642-0005-0637	Outer Tine Assbly LH (model 240)
21	642-0003-0637	Inner Tine Assbly LH (model 240)
22	714-04043	Cotter Pin, Bow Tie
23	749-04266-0637	Rear Wheel Tube
24	714-3020	Cotter Pin
25	726-0299	Push Cap
26A	734-0973	Wheel 5 x 1.38 (model 240)
26B	734-031322	Wheel 6 x 1.50, Steel (model 210)
27	749-04265-0638	Depth Stake Tube
28	711-04520	Axle Shaft

Ref.	Part Number	Description
29	710-1007	Self Tapping Screw, ⅜-16 x 1.50
30	911-0415	Clevis Pin
31	710-0809	Self Tapping Screw, ¼-20 x 1.25
32	737-04272	Pipe Plug, ¼-18 NPT
33	642-0002-0637	Inner Tine Assbly RH (model 240)
34	642-0004-0637	Outer Tine Assbly RH (model 240)
35	918-04276B	Case Assembly 61 cm (model 240)
	918-04271B	Case Assembly 40 cm (model 210)
36	721-04157	Gasket
37	786-04296-0637	Wheel Bracket
38	712-04063	Flange Lock Nut, ⅝-18
39	710-0189	Hex Head Cap Screw, ⅝-18 x 3.00
40	936-0300	Flat Washer, .406 x .875 x .059
41	712-0324	Hex Lock Nut, ¼-20
42	720-0269	Handle Grip
43	720-0274	Grip, 1.0 ID x 5.0 LG
44	647-04047-0638	Clutch Bail
45	731-05095B	Bail Holder LH
46	731-05096B	Bail Holder RH
47	731-05272	Handle Fitting
48	736-0242	Bell Washer, .340 x .872 x .060
49	936-0463	Flat Washer, .25 x .630 x .0515
50	946-04663	Clutch Cable
51	786-0340A	Handle Crank
52	786-0341	Retainer Bracket
53	642-04032-0637	Tine Assembly RH (model 210)
54	642-04031-0637	Tine Assembly LH (model 210)
55	936-0504	Wave Washer, .510 x .750 x .017
56	736-3069	Flat Washer, .531 x .875 x .15

MANUFACTURER'S LIMITED WARRANTY FOR



The limited warranty set forth below is given by MTD LLC with respect to new merchandise purchased and used in the United States and/or its territories and possessions, and by MTD Products Limited with respect to new merchandise purchased and used in Canada and/or its territories and possessions (either entity respectively, "MTD").

"MTD" warrants this product (excluding its *Normal Wear Parts and Attachments* as described below) against defects in material and workmanship for a period of two (2) years commencing on the date of original purchase and will, at its option, repair or replace, free of charge, any part found to be defective in materials or workmanship. This limited warranty shall only apply if this product has been operated and maintained in accordance with the Operator's Manual furnished with the product, and has not been subject to misuse, abuse, commercial use, neglect, accident, improper maintenance, alteration, vandalism, theft, fire, water, or damage because of other peril or natural disaster. Damage resulting from the installation or use of any part, accessory or attachment not approved by MTD for use with the product(s) covered by this manual will void your warranty as to any resulting damage.

Normal Wear Parts are warranted to be free from defects in material and workmanship for a period of thirty (30) days from the date of purchase. Normal wear parts include, but are not limited to items such as: batteries, belts, blades, blade adapters, tines, grass bags, wheels, rider deck wheels, seats, snow thrower skid shoes, friction wheels, shave plates, auger spiral rubber and tires.

Attachments — MTD warrants attachments for this product against defects in material and workmanship for a period of one (1) year, commencing on the date of the attachment's original purchase or lease. Attachments include, but are not limited to items such as: grass collectors and mulch kits.

HOW TO OBTAIN SERVICE: Warranty service is available, WITH PROOF OF PURCHASE, through your local authorized service dealer. To locate the dealer in your area:

In the U.S.A.

Check your Yellow Pages, or contact MTD LLC at P.O. Box 361131, Cleveland, Ohio 44136-0019, or call 1-800-800-7310, 1-330-220-4683 or log on to our Web site at www.mtdproducts.com.

In Canada

Contact MTD Products Limited, Kitchener, ON N2G 4J1, or call 1-800-668-1238 or log on to our Web site at www.mtdcanada.com.

This limited warranty does **not** provide coverage in the following cases:

- The engine or component parts thereof. These items may carry a separate manufacturer's warranty. Refer to applicable manufacturer's warranty for terms and conditions.
- Log splitter pumps, valves, and cylinders have a separate one-year warranty.

- Routine maintenance items such as lubricants, filters, blade sharpening, tune-ups, brake adjustments, clutch adjustments, deck adjustments, and normal deterioration of the exterior finish due to use or exposure.
- Service completed by someone other than an authorized service dealer.
- MTD does not extend any warranty for products sold or exported outside of the United States and/or Canada, and their respective possessions and territories, except those sold through MTD's authorized channels of export distribution.
- Replacement parts that are not genuine MTD parts.
- Transportation charges and service calls.
- MTD does not warrant this product for commercial use.

No implied warranty, including any implied warranty of merchantability of fitness for a particular purpose, applies after the applicable period of express written warranty above as to the parts as identified. No other express warranty, whether written or oral, except as mentioned above, given by any person or entity, including a dealer or retailer, with respect to any product, shall bind MTD. During the period of the warranty, the exclusive remedy is repair or replacement of the product as set forth above.

The provisions as set forth in this warranty provide the sole and exclusive remedy arising from the sale. MTD shall not be liable for incidental or consequential loss or damage including, without limitation, expenses incurred for substitute or replacement lawn care services or for rental expenses to temporarily replace a warranted product.

Some states do not allow the exclusion or limitation of incidental or consequential damages, or limitations on how long an implied warranty lasts, so the above exclusions or limitations may not apply to you.

In no event shall recovery of any kind be greater than the amount of the purchase price of the product sold. **Alteration of safety features of the product shall void this warranty.** You assume the risk and liability for loss, damage, or injury to you and your property and/or to others and their property arising out of the misuse or inability to use the product.

This limited warranty shall not extend to anyone other than the original purchaser or to the person for whom it was purchased as a gift.

HOW STATE LAW RELATES TO THIS WARRANTY: This limited warranty gives you specific legal rights, and you may also have other rights which vary from state to state.

IMPORTANT: Owner must present Original Proof of Purchase to obtain warranty coverage.

MTD LLC, P.O. BOX 361131 CLEVELAND, OHIO 44136-0019; Phone: 1-800-800-7310, 1-330-220-4683
MTD Canada Limited - KITCHENER, ON N2G 4J1; Phone 1-800-668-1238