

# SERVICE DATA SHEET

## Electric Ranges with ES 510 Electronic Oven Control

**NOTICE** - This service data sheet is intended for use by persons having electrical and mechanical training and a level of knowledge of these subjects generally considered acceptable in the appliance repair trade. The manufacturer cannot be responsible, nor assume any liability for injury or damage of any kind arising from the use of this data sheet.

### SAFE SERVICING PRACTICES

To avoid the possibility of personal injury and/or property damage, it is important that safe servicing practices be observed. The following are examples, but without limitation, of such practices.

1. Before servicing or moving an appliance remove power cord from electrical outlet, trip circuit breaker to OFF, or remove fuse.
2. Never interfere with the proper installation of any safety device.
3. **GROUNDING:** The standard color coding for safety ground wires is **GREEN** or **GREEN WITH YELLOW STRIPES**. Ground leads are not to be used as current carrying conductors. **It is extremely important that the service technician reestablish all safety grounds prior to completion of service. Failure to do so will create a potential safety hazard.**

4. Prior to returning the product to service, ensure that:
  - All electric connections are correct and secure.
  - All electrical leads are properly dressed and secured away from sharp edges, high-temperature components, and moving parts.
  - All uninsulated electrical terminals, connectors, heaters, etc. are adequately spaced away from all metal parts and panels.
  - All safety grounds (both internal and external) are correctly and securely reassembled.

### OVEN CALIBRATION

Set the electronic oven control for normal baking at 350°F. Obtain an average oven temperature after a minimum of 5 cycles. Press **STOP/CLEAR** to end bake mode.

### TEMPERATURE ADJUSTMENT

1. Set EOC to bake at 550°F.
2. Within 5 seconds of setting 550°F, press and hold the bake pad for approximately 15 seconds until a single beep is heard (longer may cause **F11** shorted keypad alarm).
3. Calibration offset should appear in the display.
4. Use the slew keys to adjust the oven temperature up or down 35°F in 5°F increments.
5. Once the desired (-35° to 35°) offset has been applied, press **STOP/CLEAR**.

**Note:** Changing calibration affects normal Bake mode. The adjustments made will not change the Self-Cleaning cycle temperature.

### ELECTRONIC OVEN CONTROL (REAR VIEW)

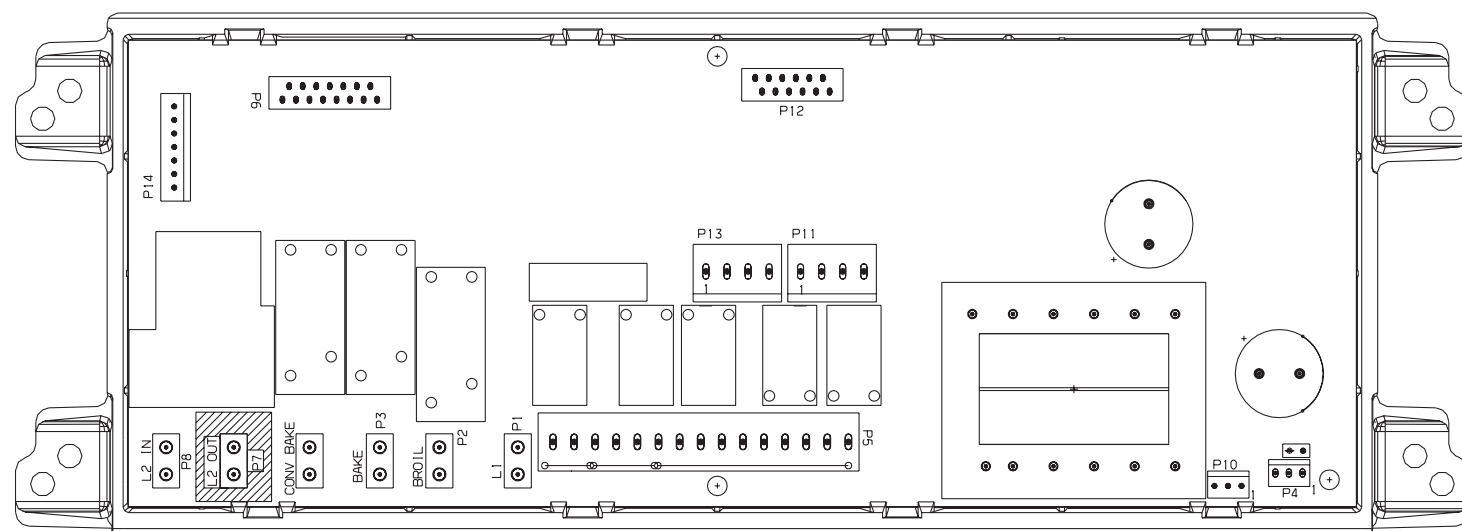

### RESISTANCE TEMPERATURE DETECTOR

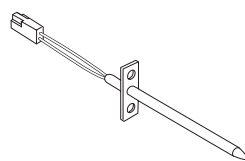

RTD SCALE	
Temperature (°F)	Resistance (ohms)
32 ± 1.9	1000 ± 4.0
75 ± 2.5	1091 ± 5.3
250 ± 4.4	1453 ± 8.9
350 ± 5.4	1654 ± 10.8
450 ± 6.9	1852 ± 13.5
550 ± 8.2	2047 ± 15.8
650 ± 9.6	2237 ± 18.5
900 ± 13.6	2697 ± 24.4

### ELECTRONIC OVEN CONTROL FAULT CODE DESCRIPTIONS

Fault Code	Likely Failure Condition/Cause	Suggested Corrective Action
<b>F10</b>	<b>Runaway Temperature.</b>	1. (F10 only) Check RTD Sensor Probe & replace if necessary. If oven is overheating, disconnect power. If oven continues to overheat when the power is reapplied, replace EOC. Severe overheating may require the entire oven to be replaced should damage be extensive. 2. (F11, 12 & 13) Disconnect power, wait 30 seconds and reapply power. 3. (F11, 12 & 13) If fault returns upon power-up, replace EOC.
<b>F11</b>	<b>Shorted Keypad.</b>	
<b>F12</b>	<b>Bad Micro Identification.</b>	
<b>F13</b>	<b>Bad EEPROM Identification/Checksum error.</b>	
<b>F30</b>	<b>Open probe connection.</b>	1. (F30 or F31) Check resistance at room temperature & compare to RTD Sensor resistance chart. If resistance does not match the RTD chart replace RTD Sensor Probe. Check Sensor wiring harness between EOC & Sensor Probe connector.  2. (F30 or F31) Check resistance at room temperature, if less than 500 ohms, replace RTD Sensor Probe. Check for shorted Sensor Probe harness between EOC & Probe connector.
<b>F31</b>	<b>Shorted Probe connection.</b>	
<b>F40</b>	<b>Cooktop Lockout error.</b>	1. (F40) Check the wiring. 2. (F40) Replace the Cooktop Lockout Control Board. 3. (F40) Replace EOC.
<b>F90</b>	<b>Maximum oven door unlock time exceeded.</b>	1. (F90, 91, 92, 93 & 94) Check the wiring between EOC & Lock Motor Micro Switch. 2. (F90, 91, 92, 93 & 94) Replace the Motor Door Latch assembly if necessary. 3. (F90, 91, 92, 93 & 94) Check for binding of the Latch Cam, Lock Motor Rod & Lock Motor Cam. 4. (F90, 91, 92, 93 & 94) Check to see if Lock Motor Coil is open. If open, replace Lock Motor Assembly. 5. (F90, 91, 92, 93 & 94) Lock Motor continuously runs - if Micro Switch is open, replace Lock Motor Assembly. 6. (F92, 93 & 94) Check oven door Light Switch - if open, replace Switch. 7. If all situations above do not solve problem, replace EOC.
<b>F91</b>	<b>Maximum oven door unlock attempts exceeded.</b>	
<b>F92</b>	<b>Maximum oven door open time exceeded.</b>	
<b>F93</b>	<b>Maximum oven door lock time exceeded.</b>	
<b>F94</b>	<b>Maximum oven door lock attempts exceeded.</b>	

### REMOVING & REPLACING WARMER DRAWER (some models)

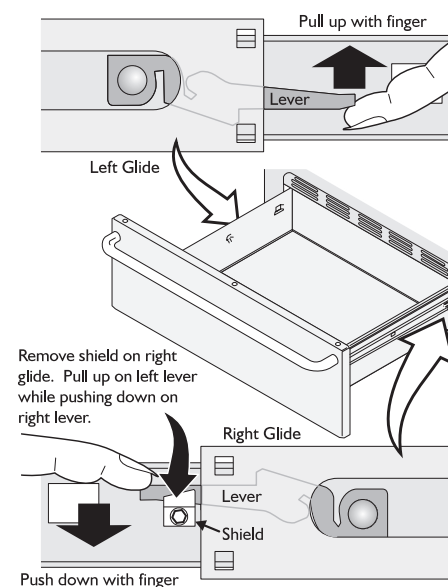

Fig. 1

#### To Remove Warmer Drawer:

1. **CAUTION** Turn power off before removing the warmer drawer.
2. Open the drawer to the fully opened position.
3. On the right glide you will find a shield attached with a hex-head screw (see figure 1). Using a 1/4" socket and ratchet remove the shield.
4. Locate glide lever on each side of drawer, pull up on the left glide lever and push down on the right glide lever.
5. Pull the drawer away from the range.

#### To Replace Warmer Drawer:

1. Replace shield on the right glide of the drawer body.
2. **Pull the bearing glides to the front** of the chassis glide (see figure 2).
3. Align the glide on each side of the drawer with the glide slots on the range.
4. Push the drawer into the range until levers "click" (approximately 2"). Pull the drawer open again to seat bearing glides into position. **If you do not hear the levers "click" or the bearing glides do not feel seated remove the drawer and repeat steps 2-4.** This will minimize possible damage to the bearing glides.



**WARNING** Electrical Shock Hazard can occur and result in serious injury or death. Disconnect appliance from electric power before cleaning and servicing the warmer drawer.

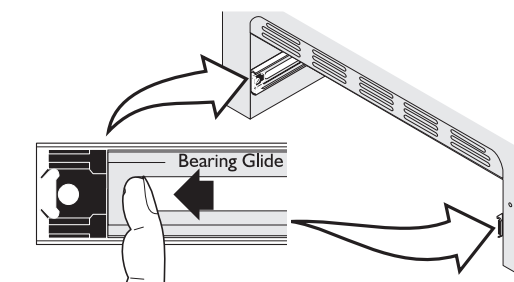

Fig. 2

**IMPORTANT**  
**DO NOT REMOVE THIS BAG**  
**OR DESTROY THE CONTENTS**  
 WIRING DIAGRAMS AND SERVICE  
 INFORMATION ENCLOSED  
**REPLACE CONTENTS IN BAG**

## CIRCUIT ANALYSIS MATRIX

	EOC Relays				Door Switch COM-NO	Warmer Drawer Lock Switch (Motor Door Latch)
	L1 to Bake	L1 to Broil	L1 to Motor Door Latch	L1 to Conv/Speed Bake Fan		
Bake/Time Bake	X	X*				X
Conv/Speed Bake	X	X*		X		X
Broil		X				X
Clean	X					
Unlocked						X
Locking			X			X
Locked						
Unlocking			X			X
Door Open						
Door Closed					X	
Cooktop Active						

Note: X=Check listed circuits. \*=Alternates with Bake element.

## ELECTRONIC OVEN CONTROL (EOC) TROUBLESHOOTING GUIDE

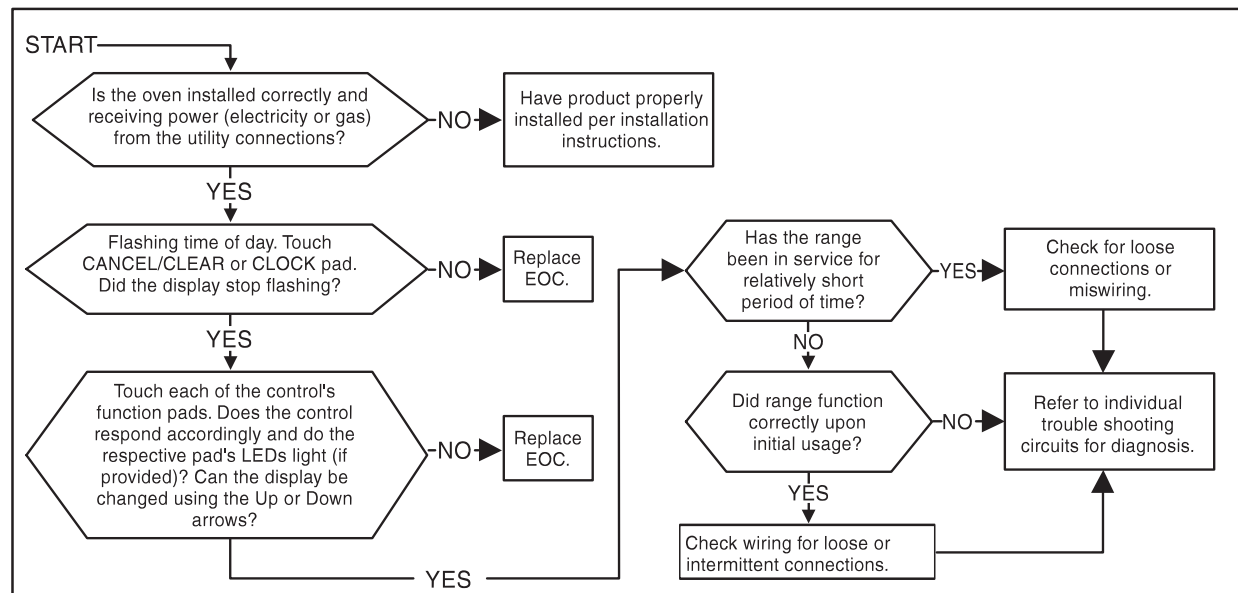

## E.O.C. CONTROL CONNECTIONS (P5)

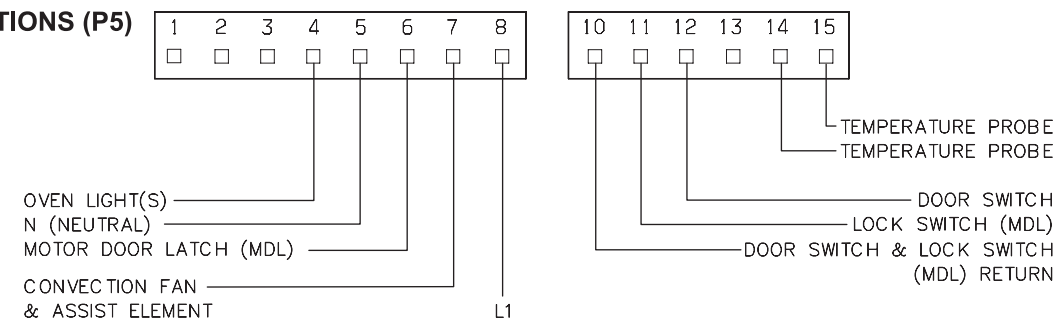

## GENERAL TROUBLESHOOTING SCHEMATIC

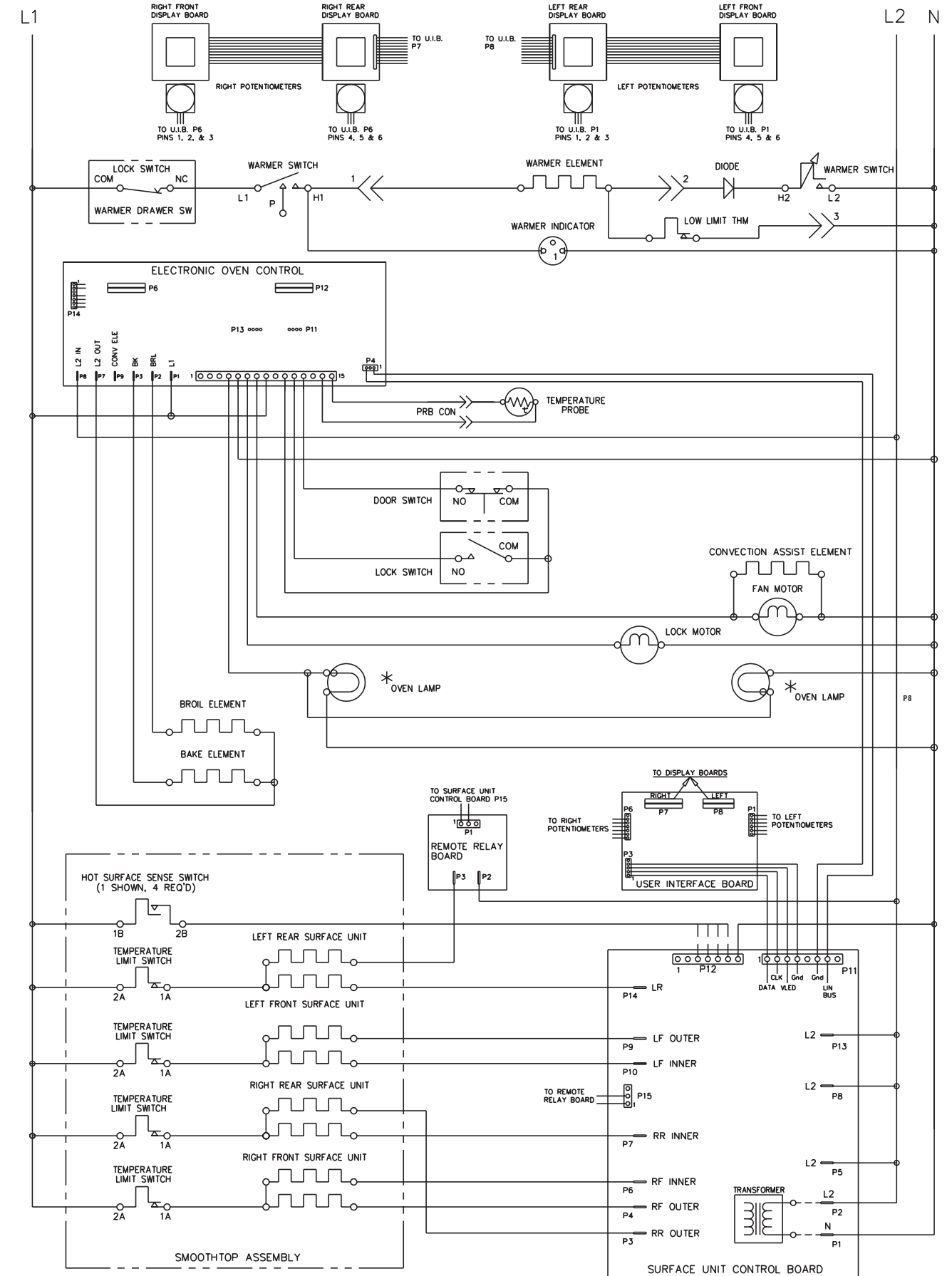

### NOTES:

1. CIRCUIT SHOWN WITH ALL CONTROLS SET TO OFF. OVEN DOOR CLOSED AND UNLOCKED.
2. COMPONENTS WITH \* DO NOT APPEAR ON ALL MODELS.

## SERVICE DATA SHEET

Electric Smoothtop Ranges with Electronic Surface Element Control (ESEC 10R)

**NOTICE** - This service data sheet is intended for use by persons having electrical and mechanical training and a level of knowledge of these subjects generally considered acceptable in the appliance repair trade. The manufacturer cannot be responsible, nor assume any liability for injury or damage of any kind arising from the use of this data sheet.

### SAFE SERVICING PRACTICES

To avoid the possibility of personal injury and/or property damage, it is important that safe servicing practices be observed. The following are examples, but without limitation, of such practices.

1. Before servicing or moving an appliance remove power cord from electrical outlet, trip circuit breaker to OFF, or remove fuse.
2. Never interfere with the proper installation of any safety device.
3. **GROUNDING:** The standard color coding for safety ground wires is *GREEN* or *GREEN WITH YELLOW STRIPES*. Ground leads are not to be used as current carrying conductors. **It is extremely important that the service technician reestablish all safety grounds prior to completion of service. Failure to do so will create a potential safety hazard.**
4. Prior to returning the product to service, ensure that:
  - All electric connections are correct and secure.
  - All electrical leads are properly dressed and secured away from sharp edges, high-temperature components, and moving parts.
  - All uninsulated electrical terminals, connectors, heaters, etc. are adequately spaced away from all metal parts and panels.
  - All safety grounds (both internal and external) are correctly and securely reassembled.

### ELECTRONIC SURFACE ELEMENT CONTROL (ESEC)

This range is equipped with an Electronic Surface Element Control (ESEC), which precisely controls the smoothtop cooking elements at multiple settings. (The Warming Zone element is not controlled by the ESEC). For the user, the elements are operated in the same way as with conventional controls, by pushing in and turning the knob to the desired setting. The setting is shown in the digital display above the knob, instead of using graphics on the control panel.

**ESEC Hot Element Indicator ("HE")** - While an element surface is hot, that element's display will show "HE". This is in place of the usual hot surface indicator light on ranges with conventional controls.

**ESEC Lockout Feature ( "- -" )** - The electronic oven control's Clean and Lock features will not operate when a surface element is ON. Conversely, the surface elements controlled by the ESEC will not operate when an oven control Clean or Lock mode is active. When the oven control is in a Clean or Lock mode, "- -" will appear in the ESEC displays to signify that the surface elements are locked out. **NOTE:** The "HE" (hot element) display will always have priority over the "- -" display.

**ESEC System Components** - The ESEC system consists of a **Power Board** (main control board mounted on the mainback of the range) and User Interface Board or **UIB** (circuit boards with digital displays, mounted in the control panel), four **Potentiometers** (push-to-turn control for each element) and the **ESEC Harness** that connects the boards and the oven control. The ESEC boards communicate with each other to control the elements and with the oven control for the lockout modes. (See the ESEC System Diagram.)

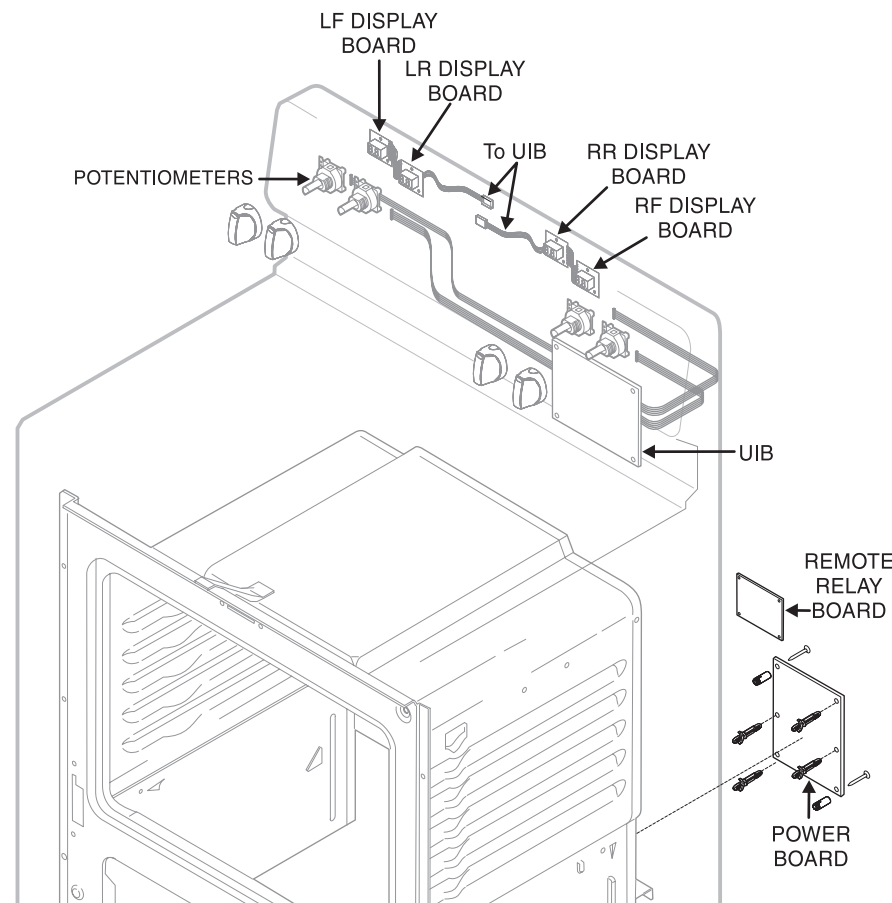

### Notes on Replacing Parts

**Replacing Potentiometers** – Each of the four push-to-turn controls is mounted to the control panel with a hex nut and lockwasher. When replacing a potentiometer, do not over-tighten the hex nut – a torque of only 5 in.-lbs. is required to properly mount the potentiometer. Over-tightening the hex nut will negatively affect the smooth feel of the knob turn and can damage the potentiometer.

**Replacing the Power Board** – When replacing the main control board (power board) on the back of the range, do not over-tighten the 2 screws that secure the Power Board. A torque of only 10 in.-lbs. is required to tighten the screws. Over-tightening the screws can damage the plastic standoffs and possibly the board itself.

## SERVICE DATA SHEET

Electric Smoothtop Ranges with Electronic Surface Element Control (ESEC 10R)

### ELECTRONIC SURFACE ELEMENT CONTROL (ESEC 10R) TROUBLESHOOTING GUIDE

Symptom	Likely Failure Condition/Cause	Suggested Corrective Action
F5 A0	Bad EEPROM checksum.	1. Replace Power Board.
F5 00	No LinBUS master communication.	1. Bad EOC. 2. Bad Power Board. 3. Bad ESEC Harness 4. Contact technical line for further assistance.
F5 01	Power Board not communicating.	1. Bad ESEC harness. 2. Bad UIB. 3. Bad Power Board. 4. Contact technical line for further assistance.
F5 02	UIB not communicating.	1. Bad UIB. 2. Bad Power Board. 3. Bad ESEC harness. 4. Contact technical line for further assistance.
F5 F0	Watchdog timer timed out - Power Board.	1. Replace Power Board.
F5 FF	Watchdog timer timed out - UIB.	1. Replace UIB.
F7 10 F7 20 F7 30 F7 40	Potentiometer LF is open. Potentiometer LR is open. Potentiometer RR is open. Potentiometer RF is open.	1. Bad potentiometer. 2. Bad UIB. 3. Contact technical line for assistance.
F7 11 F7 21 F7 31 F7 41	Potentiometer LF is shorted. Potentiometer LR is shorted. Potentiometer RR is shorted. Potentiometer RF is shorted.	1. Bad potentiometer. 2. Bad UIB. 3. Contact technical line for assistance.
F7 12 F7 22 F7 32 F7 42	Potentiometer for LF is wrong value. Potentiometer for LR is wrong value. Potentiometer for RR is wrong value. Potentiometer for RF is wrong value.	1. Bad potentiometer. 2. Bad UIB. 3. Check for moisture. 4. Contact technical line for assistance.

**IMPORTANT**  
**DO NOT REMOVE THIS BAG**  
**OR DESTROY THE CONTENTS**  
 WIRING DIAGRAMS AND SERVICE  
 INFORMATION ENCLOSED  
**REPLACE CONTENTS IN BAG**

# ESEC SYSTEM DIAGRAM

