



# Air Conditioners

**Safety Information**  
 Adapter Plugs .....3  
 Connect Electricity .....2  
 Extension Cords .....3  
 Safety Precautions .....2

**Operating Instructions** ..... 4, 5

**Care and Cleaning**  
 Air Filter .....6  
 Grille and Case .....6  
 Outdoor Coils .....6

**Installation Instructions**  
 Through the Wall Installation—  
 Optional .....15  
 Window Installation .....7-14

**Troubleshooting Tips** .....16  
 Normal Operating Sounds .....16

**Consumer Support**  
 Consumer Support .....Back Cover  
 Product Registration .....17, 18  
 Warranty .....19

**Owner's Manual & Installation Instructions**

- AVE12
- AVE15
- AVE18
- AVE22

**Write the model and serial numbers here:**

**Model #** \_\_\_\_\_

**Serial #** \_\_\_\_\_

Find these numbers on a label on the side of the air conditioner and/or on a label near the air discharge area.



# IMPORTANT SAFETY INFORMATION. READ ALL INSTRUCTIONS BEFORE USING.

## **⚠ WARNING!**

For your safety, the information in this manual must be followed to minimize the risk of fire, electric shock or personal injury.



## SAFETY PRECAUTIONS

- Use this appliance only for its intended purpose as described in this Owner's Manual.
  - This air conditioner must be properly installed in accordance with the Installation Instructions before it is used.
  - Never unplug your air conditioner by pulling on the power cord. Always grip plug firmly and pull straight out from the receptacle.
  - Repair or replace immediately all electric service cords that have become frayed or otherwise damaged. Do not use a cord that shows cracks or abrasion damage along its length or at either the plug or connector end.
  - Turn the mode control **OFF** and unplug your air conditioner before making any repairs or cleaning.
- NOTE:** We strongly recommend that any servicing be performed by a qualified individual.
- For your safety...do not store or use combustible materials, gasoline or other flammable vapors or liquids in the vicinity of this or any other appliance.

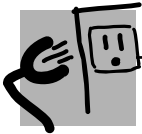

## HOW TO CONNECT ELECTRICITY

*Do not, under any circumstances, cut or remove the third (ground) prong from the power cord. For personal safety, this appliance must be properly grounded.*

The power cord of this appliance is equipped with a 3-prong (grounding) plug which mates with a standard 3-prong (grounding) wall outlet to minimize the possibility of electric shock hazard from this appliance.

Have the wall outlet and circuit checked by a qualified electrician to make sure the outlet is properly grounded.

Where a 2-prong wall outlet is encountered, it is your personal responsibility and obligation to have it replaced with a properly grounded 3-prong wall outlet.

The air conditioner should always be plugged into its own individual electrical outlet which has a voltage rating that matches the rating plate.

This provides the best performance and also prevents overloading house wiring circuits which could cause a fire hazard from overheated wires.

See the Installation Instructions, *Electrical Requirements* section for specific electrical connection requirements.

**⚠ WARNING!****USE OF EXTENSION CORDS—115-Volt models only**

*Because of potential safety hazards under certain conditions, we strongly recommend against the use of an extension cord.*

However, if you must use an extension cord, it is absolutely necessary that it be a UL-listed, 14 gauge, 3-wire grounding type appliance extension cord having a grounding type plug and outlet and that the electrical rating of the cord be 15 amperes (minimum) and 125 volts.

**⚠ CAUTION:**

**DO NOT use an extension cord with any of the 230/208 volt models.**

**USE OF ADAPTER PLUGS—115-Volt models only**

*Because of potential safety hazards under certain conditions, we strongly recommend against the use of an adapter plug.*

However, if you must use an adapter, where local codes permit, a **temporary connection** may be made to a properly grounded 2-prong wall outlet by use of a UL-listed adapter available at most local hardware stores.

The larger slot in the adapter must be aligned with the larger slot in the wall outlet to provide proper polarity in the connection of the power cord.

When disconnecting the power cord from the adapter, always hold the adapter in place with one hand while pulling the power cord plug with the other hand. If this is not done, the adapter ground terminal is very likely to break with repeated use.

If the adapter ground terminal breaks, **DO NOT USE** the air conditioner until a proper ground has been established.

*Attaching the adapter ground terminal to a wall outlet cover screw does not ground the appliance unless the cover screw is metal, and not insulated, and the wall outlet is grounded through the house wiring. You should have the circuit checked by a qualified electrician to make sure the outlet is properly grounded.*



**READ AND FOLLOW THIS SAFETY INFORMATION CAREFULLY.**

**SAVE THESE INSTRUCTIONS**

## About the controls on the air conditioner.

Features and appearance will vary.

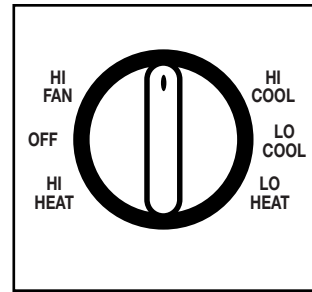
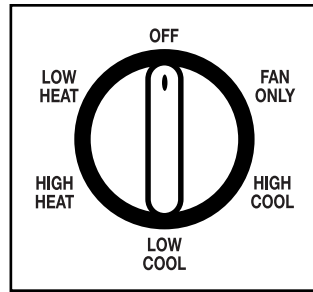

### 1 MODE CONTROLS

Your model will have one of the above type controls.

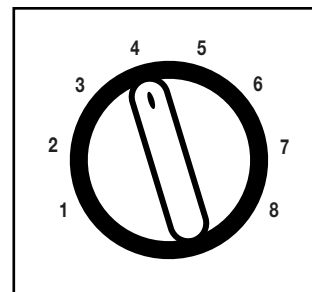
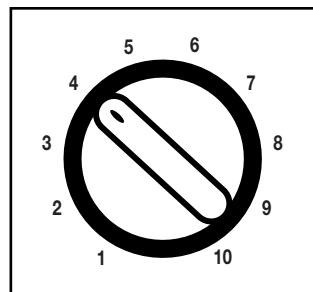

### 2 TEMP CONTROLS

Your model will have one of the above type controls.



## Controls

**1 Mode Controls**  
**HIGH COOL** and **LOW COOL** provide cooling with different fan speeds.

**HIGH HEAT** and **LOW HEAT** provide heating with different fan speeds.

**FAN** setting provides air circulation and filtering without cooling or heating.

**NOTE:** If you move the mode control from a cool setting to **OFF** or to a fan setting, wait at least 3 minutes before switching back to a cool setting.

### Cooling Descriptions

**For Normal Cooling**—Select **HIGH COOL** or **LOW COOL** with the temp control at midpoint.

**For Maximum Cooling**—Select **HIGH COOL** with the temp control at the highest number available on your knob.

**For Quieter & Nighttime Cooling**—Select **LOW COOL** with the temp control at midpoint.

### Heating Descriptions

**For Normal Heating**—Select **HIGH HEAT** or **LOW HEAT** with the temp control at midpoint.

**For Maximum Heating**—Select **HIGH HEAT** with the temp control at the lowest number available on your knob.

**For Quieter & Nighttime Heating**—Select **LOW HEAT** with the temp control at midpoint.

### 2 Temp Controls

The temp control is used to maintain the room temperature. The compressor will cycle on and off to keep the room at the same level of comfort.

In the Cooling mode, the higher number selected, the cooler the indoor room will become.

In the Heating mode, the lower the number selected, the warmer the indoor room will become.

Additional controls and important information.

**Vent Control**

When set at **CLOSED**, only the air inside the room will be circulated and conditioned. When set at **OPEN**, some inside air is exhausted outside.

On some models, the vent control is located above the control knobs.



On some models, the vent control is located beside the air louvers.

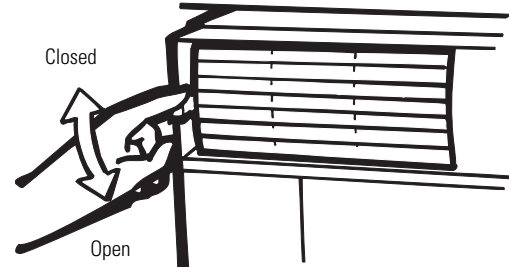

**Air Direction**

Two levers on each side of the grille let you control the air direction left or right.

Fingertip pressure on the tabs adjusts the air direction up or straight ahead.

**Do not adjust the louvers down any lower than straight out.** Air that is blown down will affect the thermostat, causing the air conditioner to turn off before the room is cooled.

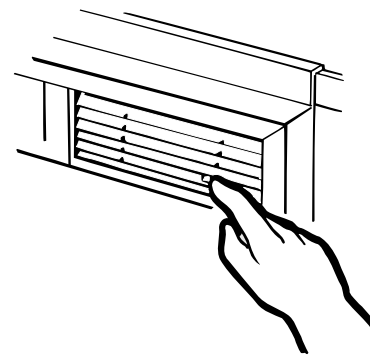

## Care and cleaning of the air conditioner.

---

### Grille and Case

Turn the air conditioner off and remove the plug from the wall outlet before cleaning.

To clean, use water and a mild detergent. Do not use bleach or abrasives.

---

### Outdoor Coils

The coils on the outdoor side of the air conditioner should be checked regularly. If they are clogged with dirt or soot they may be professionally steam cleaned, a service available through your GE service outlet.

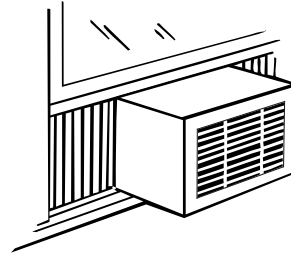

### Air Filter

The air filter behind the front grille should be checked and cleaned at least every 30 days or more often if necessary.

Clean the filter with warm, soapy water. Rinse and let the filter dry before replacing it.

**CAUTION:** DO NOT operate the air conditioner without a filter because dirt and lint will clog it and reduce performance.

**To remove:**

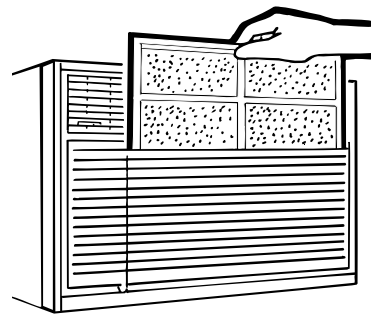

Lift the top of the filter and pull it up and out.

# Preparing to install the air conditioner.

Read these instructions completely and carefully.



## Before You Begin

**NOTE TO INSTALLER:** Leave these instructions with the air conditioner after installation is completed.

**NOTE TO CONSUMER:** Keep this Owner's Manual and Installation Instructions for future use.

### IMPORTANT NOTES:

For personal safety, this air conditioner must be properly grounded.

It is important to have the wall outlet and circuit checked by a qualified electrician if there is any doubt as to whether a proper ground exists.

Follow National Electric Codes (NEC) and/or local codes and ordinances.



### CAUTION:

Do not, under any circumstances, cut or remove the third (ground) prong from the power cord.

Do not change the plug on the power cord of this air conditioner.

Aluminum house wiring may present special problems—consult a qualified electrician.



## Electrical Requirements



Some models require 115/120-volt a.c., 60 Hz grounded outlet protected with a 15-amp time delay fuse or circuit breaker.

The 3-prong grounding plug minimizes the possibility of electric shock hazard. If the wall outlet you plan to use is only a 2-prong outlet, it is your responsibility to have it replaced with a properly grounded 3-prong wall outlet.



Some models require 230/208-volt a.c., protected with a time delay fuse or circuit breaker. These models should be installed on their own single branch circuit for best performance and to prevent overloading house or apartment wiring circuits, which could cause a possible fire hazard from overheating wires.

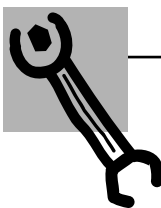

## Tools You Will Need

- Flat-blade screwdriver
- Phillips-head screwdriver
- Hex driver or adjustable wrench
- Ruler or tape measure
- Scissors or knife
- Pencil
- Level
- Hammer

# Window Installation Instructions.

Read the section *Preparing to Install the Air Conditioner before beginning.*

Parts Included

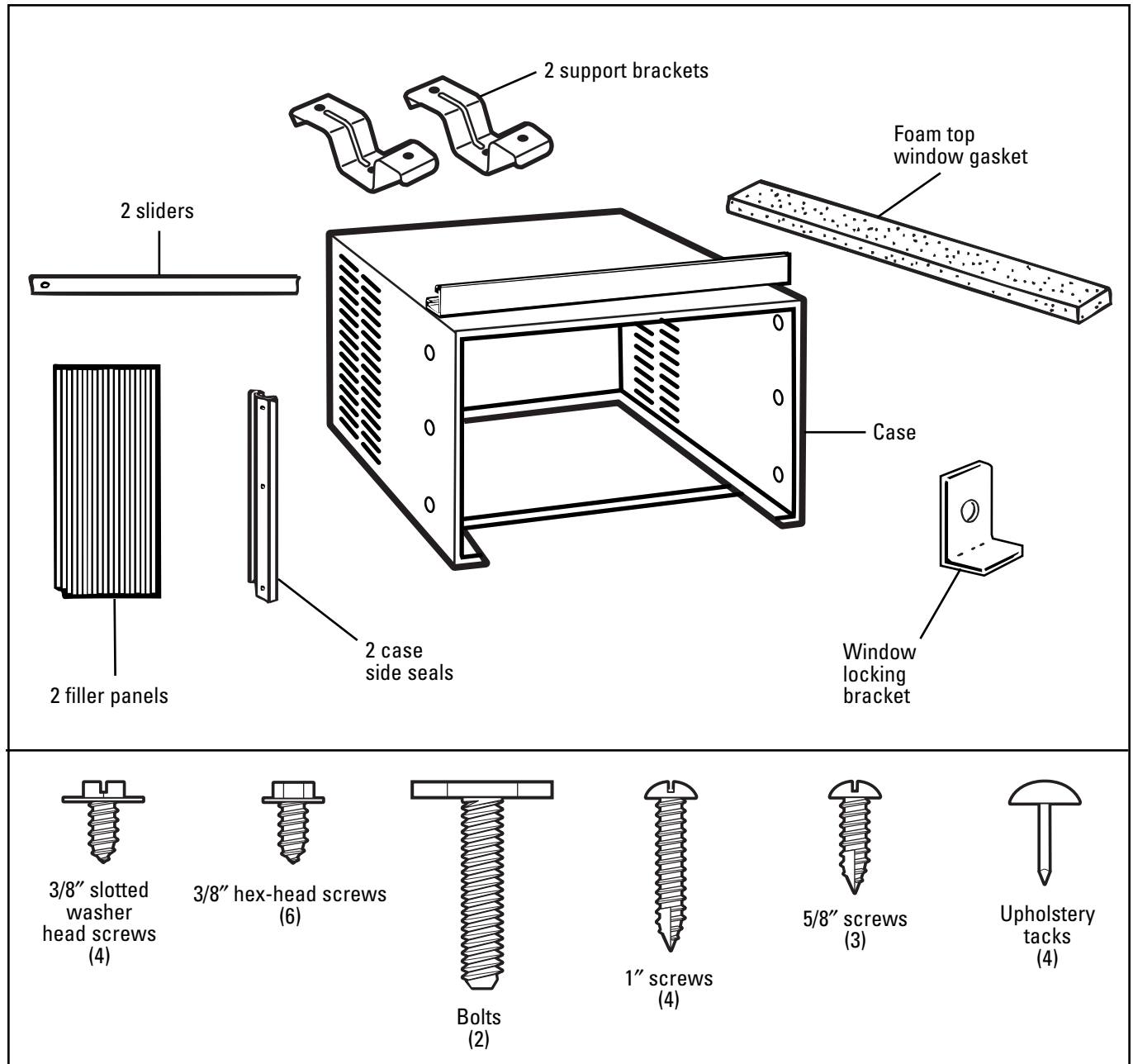



Read completely, then follow step-by-step.

# 1

## Window Requirements

- These instructions are for a standard double-hung window. You will need to modify them for other types of windows.
- The air conditioner can be installed without the accordion panels if needed to fit in a narrow window. See the window opening dimensions below.
- All supporting parts must be secured to firm wood, masonry or metal.
- The electrical outlet must be within reach of the power cord.

**AVE12 model**

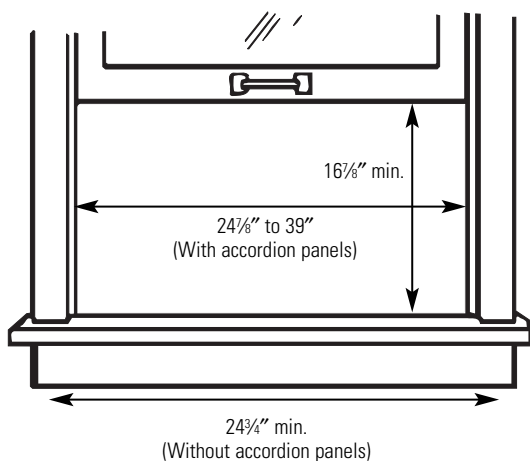

**AVE15, AVE18 and AVE22 models**

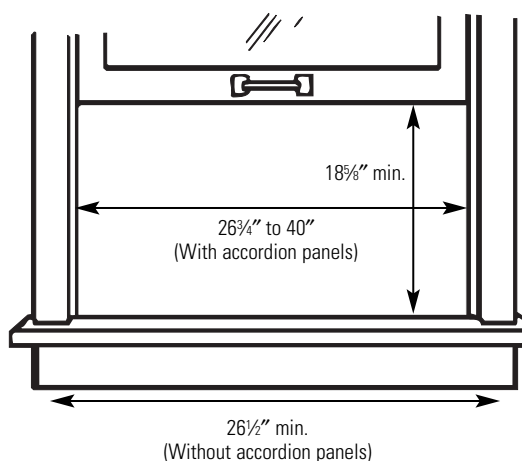

# 2

## Storm Window Requirements

A storm window frame will not allow the air conditioner to tilt towards the outside and will keep it from draining properly. To adjust for this, attach a piece of wood to the stool.

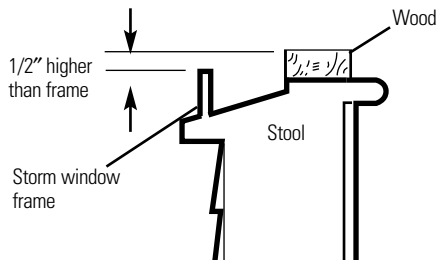

### WOOD PIECES—

**WIDTH:** 2"

**LENGTH:** Long enough to fit inside the window frame.

**THICKNESS:** To determine the thickness, place a piece of wood on the stool to make it 1/2" higher than the top of the storm window frame.

Attach securely with nails or screws provided by the installer.

# Window Installation Instructions.

## 3

### Remove the Air Conditioner from the Case

- A** On some models, open the control door and remove the screw. Remove the front grille.

*Keep this screw to reattach the grille later.*

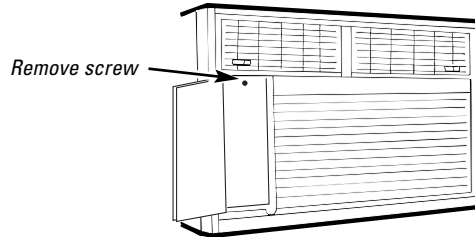

On some models, remove the air filter and the 2 screws behind the filter. Lift off the front grille.

*Keep these screws to reattach the grille later.*

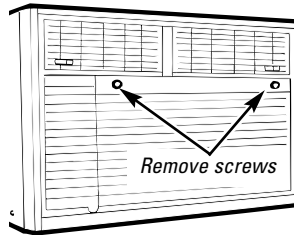

- B** Remove one screw from each side of the case. Keep these ground/anti-theft screws so they may be replaced at the end of the installation.

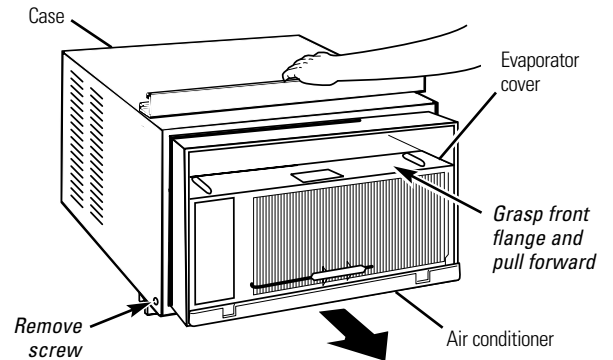

- C** Slide the air conditioner from the case by grasping front flange of the evaporator cover and pulling forward while bracing the case.

**NOTE:** *The air conditioner is very heavy. It may require two or more people to remove it from the case.*

# 4

## Install the Side Seals and the Case in the Window

- A** Open the window and mark the centerline on the stool.

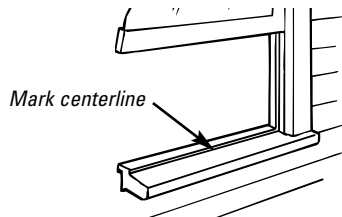

- B** Attach the case side seals on the outside of the case by using three 3/8" hex-head screws on each side.

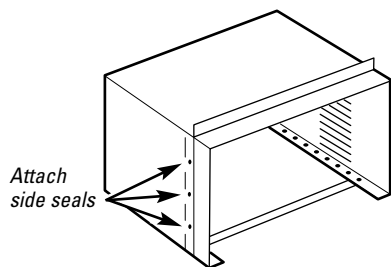

- C** Place the sliders, one on each side, into the top retainer bar.

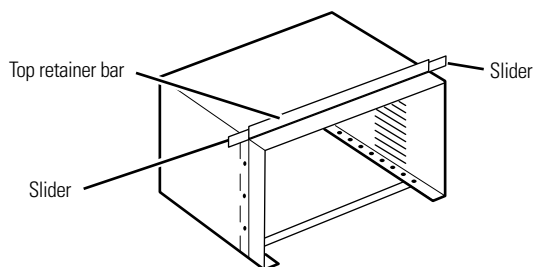

- D** Carefully place the case in the window and align the center of the bottom tie bar with the centerline on the window stool. Do not release your grip on the case until the window is in its final position.

- E** Close the window until it touches behind the top retainer bar. Do not close the window so tightly that the sliders cannot move.

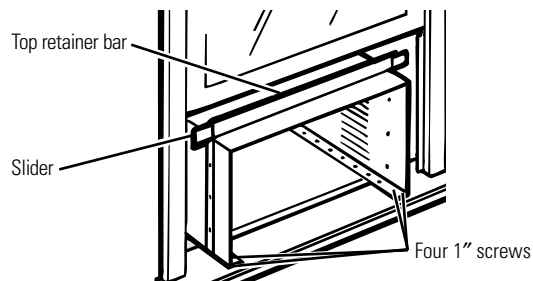

- F** Secure the case to the window stool using two 1" screws on each side.

## Window Installation Instructions.

5

### Install the Support Brackets

Thread a bolt into each support bracket.

Position the brackets on the case bottom so they will be near the outermost point on the window sill. (Brackets may be positioned in either direction, for maximum support, depending on the depth of the window sill.) Attach a support bracket to each side of the case bottom using two 3/8" slotted washer head screws on each side. The case should be slightly tilted to the outside. Use a level; about a 1/2 bubble will be the correct case slant to the outside.

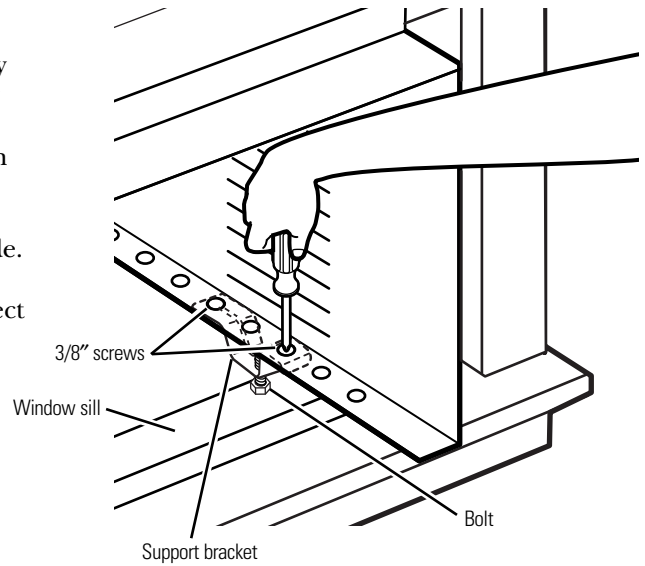

6

### Measure and Cut the Window Filler Panels

- A** Measure the distance "X" between the face of the window molding and the side of the case. Measure both sides of the case separately.

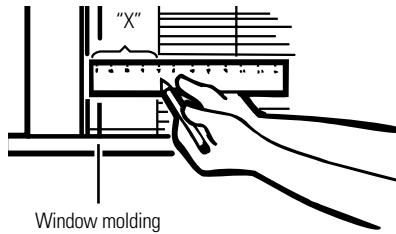

- C** Using a sharp knife, mark the groove until the filler panel becomes weak enough to break apart.



- B** Subtract 3/16" (one groove) from "X" to determine the required width you need to cut the filler panels.

## 7

**Install the Window Filler Panels and Locking Bracket**

- A** Insert the cut edge of the filler panel into the case side seal groove.

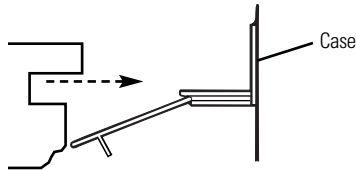

*Leave a small space at the bottom of the case side seal groove.*

- B** Flex and push the filler panel backward toward the window frame until it clears the window stool.

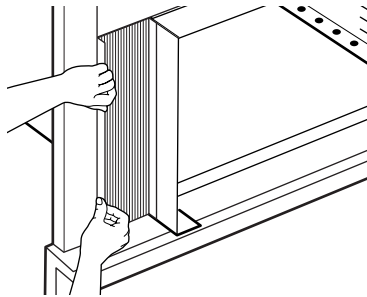

- C** Slide the filler panel out from the air conditioner case. Make sure it contacts the window molding.

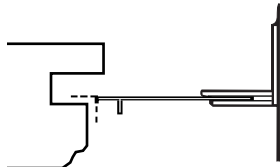

*Slide the filler panel into place.*

- D** Use upholstery tacks to attach the filler panel to the face of the window molding through the holes provided.

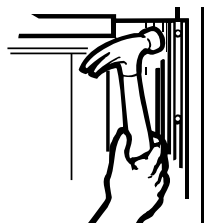

- E** Pull the sliders out until they contact the face of the window molding. (Note: If a slider has slipped into the top retainer bar and cannot be pulled out, use the slider on the other side to tap it out.)
- F** Pull the window down tightly and lock it in place with 5/8" screws.

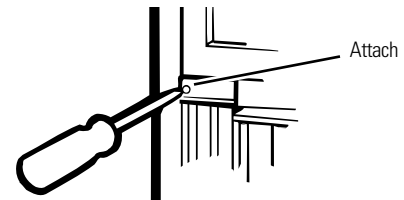

*Attach through the holes on each side of the window sash*

- G** Attach the window locking bracket with a 5/8" screw.

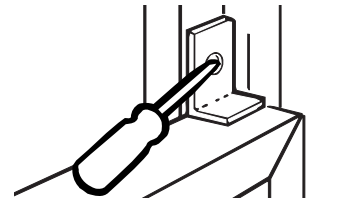

## Window Installation Instructions.

8

### Install the Window Gasket and Replace the Air Conditioner

- A** Cut the foam top window gasket to the window width. Stuff the foam between the glass and the window to prevent air and insects from getting into the room.

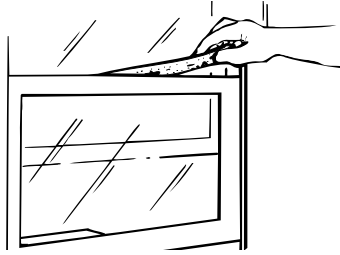

- B** Slide the air conditioner into the case and replace the front grille. Install the two ground/anti-theft screws removed at the beginning of the installation.

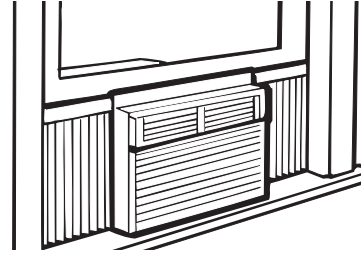

- C** Make sure the unit is **OFF** before inserting cord plug into the outlet.
- D** Check all seals and plug any remaining air gaps with a suitable weatherproof caulk.

# Through the Wall Installation Instructions—Optional.

The case may be installed through the wall in both existing and new construction.

Read completely, then follow step-by-step.

1

## IMPORTANT

Through the wall installation is not appropriate if any of the side louvers in the case will be obstructed by the wall.

All side louvers in the case must project on the outdoor side of the wall.

The room side of the case must project into the room at least 1<sup>3</sup>/<sub>4</sub>" from the finished wall.

The case must be installed level from side-to-side and with a slight tilt from front to rear. Use a level; about a 1/2 bubble will be the correct case slant to the outside.

- A** Remove the air conditioner from the case. For specific instruction, refer to the *Window Installation Instructions*.
- B** Make certain a wall receptacle is available close to the hole location or make arrangements to install a receptacle.

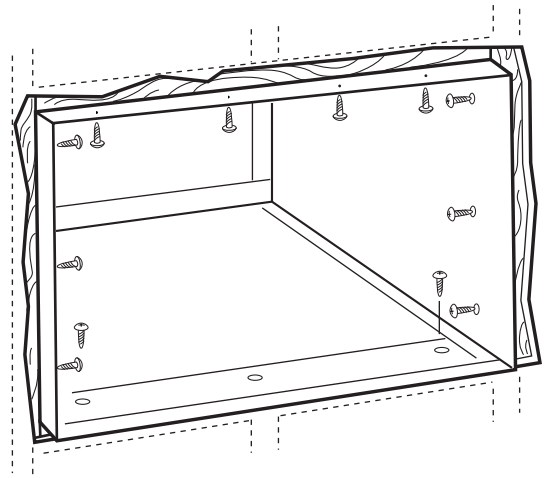

- C** Place the case in the wall opening and secure with 12 1" long #10 wood screws.

**NOTE:** Drill pilot holes, if necessary, for proper installation. If the frame is oversized, use shims to prevent case distortion.

2

## Finish the Wall Opening

Caulk all four sides on the outdoor side of the case to prevent moisture from getting through to the interior wall. Use of flashing (drip rail) will further prevent water from dripping inside the wall and down the outside of the building.

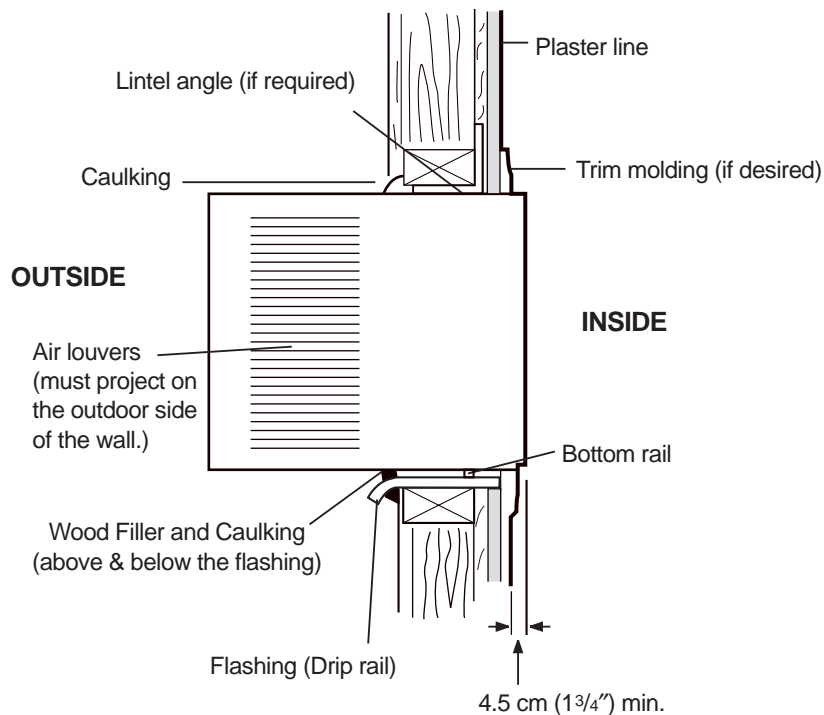

## Before you call for service...



### Troubleshooting Tips

Save time and money! Review the charts on the following pages first and you may not need to call for service.

| <b>Problem</b>                                    | <b>Possible Causes</b>  | <b>What To Do</b>  |
|---|---|--|
| <b>Air conditioner does not start</b>             | <b>The air conditioner is unplugged.</b>  | • Make sure the air conditioner plug is pushed completely into the outlet.   |
|   | <b>The fuse is blown/circuit breaker is tripped.</b>                                | • Check the house fuse/circuit breaker box and replace the fuse or reset the breaker.  |
|   | <b>Power failure.</b>   | • If power failure occurs, turn the mode control to <b>OFF</b> . When power is restored, wait 3 minutes to restart the air conditioner to prevent tripping of the compressor overload. |
| <b>Air conditioner does not cool as it should</b> | <b>Airflow is restricted.</b>   | • Make sure there are no curtains, blinds or furniture blocking the front of the air conditioner.  |
|   | <b>The temp control may not be set high enough.</b>                                 | • Turn the knob to a higher number. The highest setting provides maximum cooling.  |
|   | <b>The air filter is dirty.</b>   | • Clean the filter at least every 30 days. See the <i>Operating Instructions</i> section.  |
|   | <b>The room may have been hot.</b>  | • When the air conditioner is first turned on you need to allow time for the room to cool down.  |
|   | <b>Cold air is escaping.</b>  | • Check for open furnace floor registers and cold air returns.<br>• Set the air conditioner's vent to the closed position.   |
|   | <b>Cooling coils have iced up.</b>  | • See freezing up below.   |
| <b>Air conditioner freezing up</b>                | <b>Ice blocks the air flow and stops the air conditioner from cooling the room.</b> | • Set the mode control at <b>FAN</b> setting, or <b>HIGH COOL</b> with the temp at <b>1</b> or <b>2</b> . Wait for approximately one hour, then reset to desired temperature.          |
| <b>Air conditioner does not warm as it should</b> | <b>Airflow is restricted.</b>   | • Make sure there are no curtains, blinds or furniture blocking the front of the air conditioner.  |
|   | <b>The temp control may not be set low enough.</b>                                  | • Turn the knob to a lower number. The lowest setting provides maximum warming.  |
|   | <b>The air filter is dirty.</b>   | • Clean the filter at least every 30 days. See the <i>Operating Instructions</i> section.  |
|   | <b>The room may have been cold.</b>   | • When the air conditioner is first turned on you need to allow time for the room to warm up.  |
|   | <b>Warm air is escaping.</b>  | • Check for open furnace floor registers and cold air returns.   |

### Normal Operating Sounds

- You may hear a pinging noise caused by water being picked up and thrown against the condenser on rainy days or when the humidity is high. This design feature helps remove moisture and improve efficiency.
- You may hear the thermostat click when the compressor cycles on and off.
- Water will collect in the base pan during high humidity or on rainy days. The water may overflow and drip from the outdoor side of the unit.
- The fan may run even when the compressor does not.



## GE Service Protection Plus™

GE, a name recognized worldwide for quality and dependability, offers you Service Protection Plus™—comprehensive protection on all your appliances—**No Matter What Brand!**

**Benefits Include:**

- Backed by GE
- All brands covered
- Unlimited service calls
- All parts and labor costs included
- No out-of-pocket expenses
- No hidden deductibles
- One 800 number to call

***We'll Cover Any Appliance.  
Anywhere. Anytime.\****

You will be completely satisfied with our service protection or you may request your money back on the remaining value of your contract. No questions asked. It's that simple.

Protect your refrigerator, dishwasher, washer and dryer, range, TV, VCR and much more—**any brand!** Plus there's no extra charge for emergency service and low monthly financing is available. Even icemaker coverage and food spoilage protection is offered. You can rest easy, knowing that all your valuable household products are protected against expensive repairs.

Place your confidence in GE and call us in the U.S. toll-free at **800-626-2224** for more information.

\*All brands covered, up to 20 years old, in the continental U.S.

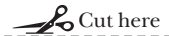

Please place in envelope and mail to:

***General Electric Company***  
**Warranty Registration Department**  
**P.O. Box 32150**  
**Louisville, KY 40232-2150**

# Consumer Product Ownership Registration

Dear Customer:

Thank you for purchasing our product and thank you for placing your confidence in us.

We are proud to have you as a customer!

Follow these three steps to protect your new appliance investment:

# 1

**Complete and mail your Consumer Product Ownership Registration today.** Have the peace of mind of knowing we can contact you in the unlikely event of a safety modification.

# 2

After mailing the registration below, store this document in a safe place. It contains information you will need should you require service. Our service number is 800 GE CARES (800-432-2737).

# 3

Read your Owner's Manual carefully. It will help you operate your new appliance properly.

Model Number

Serial Number

**Important: If you did not get a registration card with your product, detach and return the form below to ensure that your product is registered, or register online at [www.GEAppliances.com](http://www.GEAppliances.com).**

 Cut here

## Consumer Product Ownership Registration



Model Number

Serial Number

Mr.  Ms.  Mrs.  Miss

First Name

Last Name

Street Address

Apt. #

E-mail Address

City

State

Zip Code

Date Placed In Use  
Month

Day

Year

Phone Number  -  -

Occasionally, we may allow selected companies to send you information.

Check here if you do not want this information.



**GE Appliances**

General Electric Company  
Louisville, Kentucky  
[www.GEAppliances.com](http://www.GEAppliances.com)

# Air Conditioner Warranty.



All warranty service provided by our Factory Service Centers, or an authorized Customer Care® technician. To schedule service, on-line, 24 hours a day, contact us at [www.GEAppliances.com](http://www.GEAppliances.com), or call 800-GE-CARES.

Staple your receipt here.  
Proof of the original purchase date is needed to obtain service under the warranty.

| For The Period Of:  | We Will Replace:  |
|---|---|
| <b>One Year</b><br>From the date of the original purchase   | <b>Any part</b> of the air conditioner which fails due to a defect in materials or workmanship. During this <b>full one-year warranty</b> , we will also provide, <b>free of charge</b> , all labor and in-home service to replace the defective part.  |
| <b>Five Years</b><br>From the date of the original purchase | <b>Any part of the sealed refrigerating system</b> (the compressor, condenser, evaporator and all connecting tubing) which fails due to a defect in materials or workmanship. During this <b>four-year additional warranty</b> , we will also provide, <b>free of charge</b> , all labor and in-home service to replace the defective part. |

## What Is Not Covered:

- Service trips to your home to teach you how to use the product.
- Improper installation. If you have an installation problem, or if the air conditioner is of improper cooling capacity for the intended use, contact your dealer or installer. You are responsible for providing adequate electrical connecting facilities.
- Failure of the product resulting from modifications to the product or due to unreasonable use including failure to provide reasonable and necessary maintenance.
- In commercial locations labor necessary to move the unit to a location where it is accessible for service by an individual technician.
- Replacement of house fuses or resetting of circuit breakers.
- Failure due to corrosion on models not corrosion-protected.
- Damage to the product caused by improper power supply voltage, accident, fire, floods or acts of God.
- Incidental or consequential damage caused by possible defects with this air conditioner.

*This warranty is extended to the original purchaser and any succeeding owner for products purchased for home use within the USA. In Alaska, the warranty excludes the cost of shipping or service calls to your home.*

*Some states do not allow the exclusion or limitation of incidental or consequential damages. This warranty gives you specific legal rights, and you may also have other rights which vary from state to state. To know what your legal rights are, consult your local or state consumer affairs office or your state's Attorney General.*

**Warrantor: General Electric Company, Louisville, KY 40225**

## Consumer Support.

---



### *GE Appliances Website*

[www.GEAppliances.com](http://www.GEAppliances.com)

Have a question or need assistance with your appliance? Try the GE Appliances Website 24 hours a day, any day of the year! For greater convenience and faster service, you can now download Owner's Manuals, order parts, catalogs, or even schedule service on-line. You can also "Ask Our Team of Experts™" your questions, and so much more...

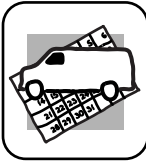

### *Schedule Service*

[www.GEAppliances.com](http://www.GEAppliances.com)

Expert GE repair service is only one step away from your door. Get on-line and schedule your service at your convenience 24 hours any day of the year! Or call 800-GE-CARES (800-432-2737) during normal business hours.



### *Real Life Design Studio*

[www.GEAppliances.com](http://www.GEAppliances.com)

GE supports the Universal Design concept—products, services and environments that can be used by people of all ages, sizes and capabilities. We recognize the need to design for a wide range of physical and mental abilities and impairments. For details of GE's Universal Design applications, including kitchen design ideas for people with disabilities, check out our Website today. For the hearing impaired, please call 800-TDD-GEAC (800-833-4322).



### *Extended Warranties*

[www.GEAppliances.com](http://www.GEAppliances.com)

Purchase a GE extended warranty and learn about special discounts that are available while your warranty is still in effect. You can purchase it on-line anytime, or call 800-626-2224 during normal business hours. GE Consumer Home Services will still be there after your warranty expires.

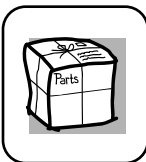

### *Parts and Accessories*

[www.GEAppliances.com](http://www.GEAppliances.com)

Individuals qualified to service their own appliances can have parts or accessories sent directly to their homes (VISA, MasterCard and Discover cards are accepted). Order on-line today, 24 hours every day or by phone at 800-626-2002 during normal business hours.

***Instructions contained in this manual cover procedures to be performed by any user. Other servicing generally should be referred to qualified service personnel. Caution must be exercised, since improper servicing may cause unsafe operation.***



### *Contact Us*

[www.GEAppliances.com](http://www.GEAppliances.com)

If you are not satisfied with the service you receive from GE, contact us on our Website with all the details including your phone number, or write to: General Manager, Customer Relations  
GE Appliances, Appliance Park  
Louisville, KY 40225



### *Register Your Appliance*

[www.GEAppliances.com](http://www.GEAppliances.com)

**Register your new appliance on-line—at your convenience!** Timely product registration will allow for enhanced communication and prompt service under the terms of your warranty, should the need arise. You may also mail in the pre-printed registration card included in the packing material, or detach and use the form in this Owner's Manual.