

Save This Manual  
For Future Reference

# **SEARS**

**owner's  
manual**

**MODEL NO.  
113.221740**

---

Serial  
Number \_\_\_\_\_

Model and serial numbers may  
be found at the rear of the  
base

You should record both model  
and serial number in a safe  
place for future use.

---

**FOR YOUR  
SAFETY**

**READ ALL  
INSTRUCTIONS  
CAREFULLY**

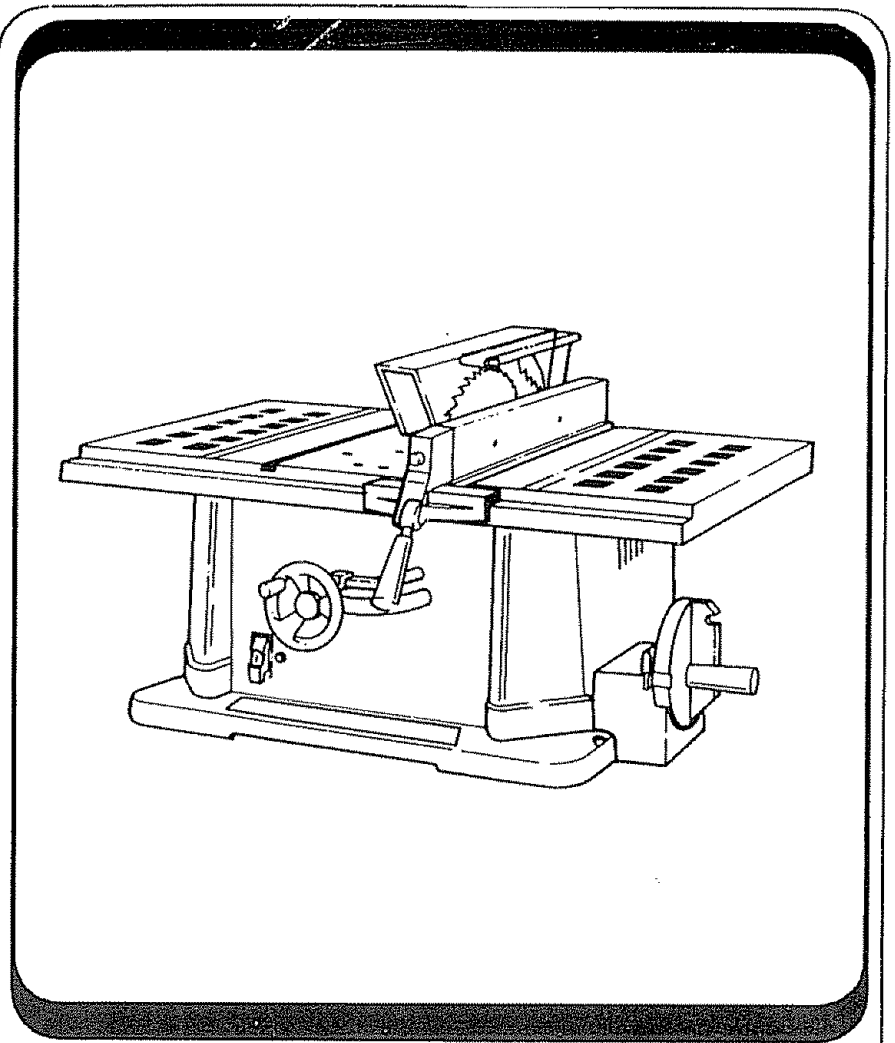

## **SEARS / CRAFTSMAN**

### **10 INCH BENCH TOP TABLE SAW**

- assembly
- operating
- repair parts

Sears, Roebuck and Co., Hoffman Estates, IL. 60179 U.S.A.

Part No. SP5754

Printed in U.S.A.

## FULL ONE YEAR WARRANTY ON CRAFTSMAN TABLE SAW

If within one year from the date of purchase, this Craftsman Table Saw fails due to a defect in material or workmanship, Sears will repair it, free of charge.

WARRANTY SERVICE IS AVAILABLE BY SIMPLY CONTACTING THE NEAREST SEARS SERVICE CENTER/DEPARTMENT THROUGHOUT THE UNITED STATES.

This warranty applies only while this product is used in the United States.

This warranty gives you specific legal rights, and you may also have other rights which vary from state to state.

Sears, Roebuck and Co., D/817 WA Hoffman Estates, IL. 60179

## Safety Instructions For Table Saw

### Safety Signal Words:

**DANGER:** means if the safety information is not followed someone will be seriously injured or killed.

**WARNING:** means if the safety information is not followed someone could be seriously injured or killed.

**CAUTION:** means if the safety information is not followed someone may be injured.

### Before Using The Saw:

**WARNING:** to avoid mistakes that could cause serious, permanent injury, do not plug the table saw in until the following steps have been satisfactorily completed.

- Completely assemble and align saw (See pages 8-18).
- Learn the use and function of the ON-OFF switch (See page 13) blade guard, spreader, anti-kickback device, miter gauge, rip fence, table insert, blade elevation and blade tilt controls (See page 20).
- Review and understand all safety instructions and operating procedures in this manual.
- Review the maintenance methods for this saw (See page 33-34).
- Find and read all the warning labels found on the saw (shown below).

### ▲WARNING

- Raised Guard Can Drop On Spinning Blade And Break
- Severe Injury Can Result
- When Used, Guard Must Be Down In Place
- Tighten Spreader Fasteners Before Use

### When Installing Or Moving The Saw:

**Avoid dangerous environment.**

- Use the saw in a dry, indoor place protected from rain. Keep work area well lighted.

**To avoid injury from unexpected saw movement.**

- Bolt or clamp the saw to firm level surface where there is plenty of room to handle and properly support the workpiece (See page 17-18).
- Support the saw so the table is level and the saw does not rock.
- When using a table extension on any side of the saw, prop up the outer end of the extension from the floor or bench top to keep the saw from tipping.
- Put the saw where neither, operators nor bystanders must stand in line with the sawblade.
- To avoid injury from electrical shock, make sure your fingers do not touch the plug's metal prongs when plugging in or unplugging the saw.
- **Never stand on tool.** Serious injury could occur if the tool tips or you accidentally hit the cutting tool. Do not store any items above or near the tool where anyone might stand on the tool to reach them.



DOUBLE INSULATED

When servicing use only identical replacement parts.

### ▲WARNING

1. Keep saw interior free of saw dust buildup to avoid fire hazard.
2. Tighten blade tilt lock lever before starting saw.

### ▲WARNING

1. Read manual before using saw.
2. Wear safety goggles that meet ANSI Z87.1 Standards.
3. Do not do freehand cuts.
4. Keep blade guard down and in place for through cuts.
5. Keep hands out of path of saw blade.
6. When ripping, use push stick when fence is set 2 inches or more from blade.
7. When ripping, use push block and auxiliary fence when fence is set between 1/2 and 2 inches from blade. Do not make rip cuts narrower than 1/2 inch.
8. Know how to reduce the risk of kickback. See instructions for ripping.
9. Do not reach around or over saw blade.
10. Turn power off and wait for blade to stop before adjusting or servicing.

## Before Each Use:

### Inspect your saw.

- To avoid injury from accidental starting, turn the switch off, unplug the saw, and remove the switch key before raising or removing the guard, changing the cutting tool, changing the setup, or adjusting anything.
- Check for alignment of moving parts, binding of moving parts, breakage of parts, saw stability, and any other conditions that may affect the way the saw works.
- If any part is missing, bent or broken in any way, or any electrical part does not work properly, turn the saw off and unplug the saw.
- Replace damaged or missing parts before using the saw again.
- Use the sawblade guard, spreader and anti-kickback pawls for any thru-sawing (whenever the blade comes through the top of the workpiece). Make sure the anti-kickback pawls work properly. Make sure the spreader is in line with sawblade (See page 10-11).
- Make sure all clamps and locks are tight and no parts have any excessive play.
- Remove adjusting keys and wrenches. Form a habit of checking for and removing keys and adjusting wrenches from table top before turning it on.
- Make sure all clamps and locks are tight and no parts have excessive play.

### To avoid injury from jams, slips or thrown pieces (kickbacks or throwbacks):

#### Inspect your blade.

- Choose the right blade or cutting accessory for the material and the type of cutting you plan to do.
- Never use grinding wheels, abrasive cutoff wheels, friction wheels (metal cutting blades) wire wheels or buffing wheels. They can fly apart explosively.
- Choose and inspect your cutting tool carefully:
  - To avoid cutting tool failure and thrown shrapnel (broken pieces of blade), use only 10 inch or smaller blades or other cutting tools marked for speeds of 5000 rpm or higher.
  - Always use unbroken, balanced blades designed to fit this saw's 5/8 inch arbor.
  - When thru-sawing (making cuts where the blade comes through the workpiece top), always use a 10 inch diameter blade. This keeps the spreader in closest to the blade.
  - Do not over tighten arbor nut. Use arbor wrenches to "snug" it securely.
  - Use only sharp blades with properly set teeth. Consult a professional blade sharpener when in doubt.
  - Keep blades clean of gum and resin.
- Never use the saw without the proper blade insert.

#### Inspect your work area.

- Keep work area clean.
- Cluttered areas and benches invite accidents. Floor must not be slippery from wax or sawdust.

- To avoid burns or other fire damage, never use the saw near flammable liquids, vapors or gases.
- To avoid injury, don't do layout, assembly, or setup work on the table while blade is spinning. It could cut or throw anything hitting the blade.

### Plan your work

- Plan ahead to protect your eyes, hands, face, ears.
- Use The Right Tool. Don't force tool or attachment to do a job it was not designed for.

### Dress for safety

- Do not wear loose clothing, gloves, neckties or jewelry (rings, wrist watches). They can get caught and draw you into moving parts.
- Wear nonslip footwear.
- Tie back long hair.
- Roll long sleeves above the elbow.
- Noise levels vary widely. To avoid possible hearing damage, wear ear plugs or muffs when using table saw for hours at a time.
- Any power saw can throw foreign objects into the eyes. This can result in permanent eye damage. Wear safety goggles (not glasses) that comply with ANSI Z87.1 (shown on package). Everyday eyeglasses have only impact resistant lenses. They are not safety glasses. Safety goggles are available at Sears retail stores. Glasses or goggles not in compliance with ANSI Z87.1 could seriously hurt you when they break.



- For dusty operations, wear a dust mask along with safety goggles.

### Inspect your workpiece.

- Make sure there are no nails or foreign objects in the part of the workpiece to be cut.
- When cutting irregularly shaped workpieces, plan your work so it will not slip and pinch the blade:
- A piece of molding for example, must lie flat or be held by a fixture or jig that will not let it twist, rock or slip while being cut. Use jigs or fixtures where needed to prevent workpiece shifting.
- Use a different, better suited type of tool for work that can't be made stable.

### Plan your cut.

- To avoid kickbacks and throwbacks - when a part or all of the workpiece binds on the blade and is thrown violently back toward the front of the saw:
  - Never cut **freehand**. Always use either a rip fence, miter gauge or fixture to position and guide the work, so it won't twist or bind on the blade and kickback.
  - Make sure there's no debris between the workpiece and its supports.

## Safety Instructions (continued)

---

- Use extra caution with large, very small or awkward workpieces:
- Use extra supports (tables, saw horses, blocks, etc.) for any workpieces large enough to tip when not held down to the table top. Never use another person as a substitute for a table extension, or as additional support for a workpiece that is longer or wider than the basic saw table, or to help feed, support or pull the workpiece.
- Never confine the piece being cut off, that is, the piece not against the fence, miter gauge or fixture. Never hold it, clamp it, touch it, or use length stops against it. It must be free to move. If confined, it could get wedged against the blade and cause a kickback or throwback.
- Never cut more than one workpiece at a time.
- Never turn your table saw "ON" before clearing everything except the workpiece and related support devices off the table.

### Plan the way you will push the workpiece through.

- **Never pull the workpiece through.** Start and finish the cut from the front of the table saw.
- **Never put your fingers or hands in the path** of the sawblade or other cutting tool.
- **Never reach in back** of the cutting tool with either hand to hold down, support the workpiece, remove wood scraps, or for any other reason.
- Avoid hand positions where a sudden slip could cause fingers or hand to move into a sawblade or other cutting tool.
- Don't Overreach. Always keep good footing and balance.
- Push the workpiece against the rotation of the blade. Never feed material into the cutting tool from the rear of the saw.
- Always push the workpiece all the way past the sawblade.
- As much as possible, keep your face and body to one side of the sawblade, out of line with a possible kickback or throwback.
- Set the cutting tool as low as possible for the cut you're planning.

### Avoid accidental starting.

- Make sure switch is "OFF" before plugging saw into a power outlet.

### Whenever Sawblade Is Spinning:

**WARNING: Don't allow familiarity (gained from frequent use of your table saw) cause a careless mistake. Always remember that a careless fraction of a second is enough to cause a severe injury.**

- Before actually cutting with the saw, watch it while it runs for a short while. If it makes an unfamiliar noise or vibrates a lot, stop immediately. Turn the saw off. Unplug the saw. Do not restart until finding and correcting the problem.

- Make sure the top of the arbor or cutting tool turns toward the front of the saw.

### Keep children away.

- Keep all visitors a safe distance from the table saw.
- Make sure bystanders are clear of the table saw and workpiece.

### Don't force tool.

- Let the blade reach full speed before cutting.
- It will do the job better and safer at its designed rate.
- Feed the workpiece into the saw only fast enough to let the blade cut without bogging down or binding.

### Before freeing jammed material.

- Turn switch "OFF".
- Unplug the saw.
- Wait for all moving parts to stop.
- Check blade, spreader and fence for proper alignment before starting again.

### To avoid throwback of cut off pieces.

- Use the guard assembly.

### To remove loose pieces beneath or trapped inside the guard.

- Turn saw "OFF".
- Remove switch key.
- Wait for blade to stop before lifting the guard.

### Before leaving the saw.

- Turn the saw off.
- Wait for blade to stop spinning.
- Unplug the saw.
- Make workshop child-proof. Lock the shop. Disconnect master switches. Remove the yellow switch key. Store it away from children and others not qualified to use the tool.

## Additional Safety Instructions for:

### Rip Type Cuts.

#### Before starting.

- Never use the miter gauge when ripping.
- Use a push stick whenever the fence is 2 or more inches from the blade.
- When thru-sawing, use an auxiliary fence and push block whenever the fence must be between 1/2 and 2 inches of the blade.
- Never thru-saw rip cuts narrower than 1/2 inch. (See "Basic Saw Operations-Ripping and Bevel Ripping" section.)
- Never rip anything shorter than 10" long.
- When using a push stick or push block, the trailing end of the board must be square. A push stick or block against an uneven end could slip off or push the work away from the fence.
- A Featherboard can help guide the workpiece. (See "Basic Saw Operation-Using Featherboards for Thru-Sawing" section.)

- Always use featherboards for any non thru rip type cuts.

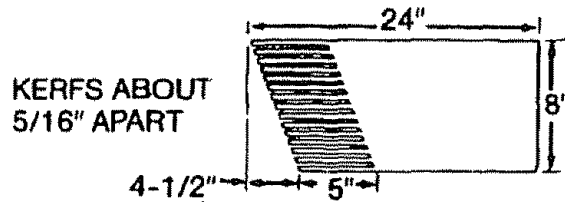

#### FEATHERBOARDS

- To avoid kickbacks and slips into the blade, make sure the rip fence is parallel to the sawblade.
- Before thru-sawing, check the anti-kickback pawls. (See "Basic Saw Operation - Using The Rip Fence." The pawls must stop a kickback once it has started. Replace or sharpen anti-kickback pawls when points become dull.
- Plastic and composition (like hardboard) materials may be cut on your saw. However, since these are usually quite hard and slippery, the anti-kickback pawls may not stop a kickback. Therefore, be especially careful in your setup and cutting procedures.

#### While thru-sawing.

- To avoid kickbacks and slips into the blade, always push forward on the section of the workpiece between the sawblade and the rip fence. Never push forward on the piece being cut off.

#### Additional Safety Instructions For: Crosscut Type Cuts.

##### Before starting.

- Never use the rip fence when crosscutting.
- An auxiliary wood facing attached to the miter gauge can help prevent workpiece twisting and throwbacks. Attach it to the holes provided. Make the facing long enough and big enough to support your work. Make sure, however, it will not interfere with the sawblade guard.
- Use jigs or fixtures to help hold any piece too small to extend across the full length of the miter gauge face during the cut. This lets you properly hold the miter gauge and workpiece and helps keep your hands away from the blade.

##### While cutting.

- To avoid blade contact, always hold the miter gauge as shown in "Basic Saw Operations - Using The Miter Gauge".

## Glossary of Terms for Woodworking

### Anti-Kickback Pawls (AKP)

Device which, when properly maintained, is designed to stop the workpiece from being kicked back at the operator during ripping operation.

### Arbor

The shaft on which a cutting tool is mounted.

### Bevel Cut

An angle cutting operation made through the face of the workpiece.

### Compound Cut

A simultaneous bevel and miter crosscutting operation.

### Crosscut

A cutting operation made across the width of the workpiece.

### Dado

A non thru cut which produces a square sided notch or trough in the workpiece.

### Featherboard

A device which can help guide workpieces during rip type operation.

### Freehand

Performing a cut without the use of fence (guide), miter gauge, fixture, hold down, or other proper device to prevent the workpiece from twisting during the cutting operation. Twisting of the workpiece can cause it to be thrown.

### Gum

A sticky, sap based residue from wood products.

### Heel

Misalignment of the sawblade such that the blade is not parallel to the miter gauge groove.

### Kerf

The amount of material removed by the blade in a through cut. Also the slot produced by the blade in a non-through or partial cut.

### Kickback

An uncontrolled grabbing and throwing of the workpiece back toward the front of the saw.

### Leading End

The end of the workpiece which, during a rip type operation, is pushed into the cutting tool first.

### Miter Cut

An angle cutting operation made across the width of the workpiece.

### Molding

A non through cut which produces a special shape in the workpiece used for joining or decoration.

### Push Stick

A device used to feed the workpiece through the saw during narrow ripping type operations. The push stick helps keep the operator's hands well away from the blade.

### Push Block

A device used for ripping type operations too narrow to allow use of a push stick.

### Rabbet

A notch in the edge of a workpiece.

### Resin

A sticky, sap based substance that has hardened.

### Revolutions Per Minute (RPM)

The number of turns completed by a spinning object in one minute.

## Glossary of Terms for Woodworking (continued)

### Rip Cut

A cutting operation along the length of the workpiece.

### Sawblade Path

The area of the workpiece or table top directly in line with either the travel of the blade or the part of the workpiece which will be, or has been, cut by the blade.

### Set

The distance that the tip of the sawblade tooth is bent (or set) outward from the face of the blade.

### Throw-Back

Throwing of pieces in a manner similar to a kickback.

### Thru-Sawing

Any cutting operation where the blade extends completely through the thickness of the workpiece.

### Trailing End

The workpiece end last cut by the blade in a ripping operation.

### Workpiece

The item on which the cutting operation is being performed. The surfaces of a workpiece are commonly referred to as faces, ends, and edges.

## Motor Specifications and Electrical Requirements

### Power Supply and Motor Specifications

The AC motor used in this saw is a universal, nonreversible type having the following specifications:

Maximum Developed H.P.	2-1/2
Voltage	120
Amperes	13
Hertz (Cycles)	60
Phase	Single
RPM	4700
Rotation of Shaft	Counterclockwise

**WARNING: To avoid electrical hazards, fire hazards, or damage to the tool, use proper circuit protection. Your saw is wired at the factory for 120v operation. Connect to a 120v, 15-amp branch circuit and use a 15-amp time delay fuse or circuit breaker. To avoid shock or fire, if power cord is worn or cut, or damaged in any way, have it replaced immediately.**

### Double Insulation

This tool is double insulated to provide a double thickness of insulation between you and the tool's electrical system. All exposed metal parts are isolated from the internal metal motor components with protecting insulation.

**WARNING: Double insulation does not take the place of normal safety precautions when operating this tool.**

#### **DANGER: To avoid electrocution:**

1. Use only identical replacement parts when servicing a tool with double insulation. Servicing should be performed by a qualified service technician.
2. Do not expose to rain, use in damp location or where floor is wet.

**This tool is intended for indoor residential use only.**

### Polarized Plug

Your unit has a plug that looks like the one shown below.

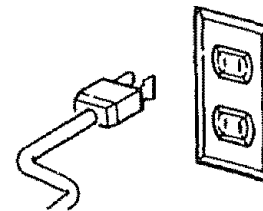

To reduce the risk of electrical shock, this appliance has a polarized plug (one blade is wider than the other). This plug will fit in a polarized outlet only one way. If the plug does not fit fully in the outlet, reverse plug. If it still does not fit, contact a qualified electrician to install the proper outlet. Do not change the plug in any way.

**WARNING: Damaged power cords can cause shock or fires. If the power cord is worn, cut, or damaged in any way, have it replaced immediately.**

**WARNING: To avoid electrical shock, do not permit fingers to touch the terminals of the plug, when installing or removing the plug to or from the outlet.**

### Motor Safety Protection

**IMPORTANT:** To avoid motor damage, this motor should be blown out or vacuumed frequently to keep sawdust from interfering with normal motor ventilation.

1. Connect this tool to a 120v, 15-amp branch circuit with a 15-amp time delay fuse or circuit breaker. Using the wrong size fuse can damage the motor.
2. If the motor won't start, turn the switch "OFF" immediately. Unplug The Tool. Check the sawblade to make sure it turns freely. If the blade is free, try to start the motor again. If the motor still does not start, refer to the "Troubleshooting Chart" on page 35.
3. If the motor suddenly stalls while cutting wood, turn the switch "OFF", unplug the tool, and free the blade from the wood. The motor may now be restarted and the cut finished.

4. Fuses may "blow" or circuit breakers may trip frequently if:
  - a. Motor Is Overloaded. Overloading can occur if you feed too rapidly or make too many start/stops in a short time.
  - b. Voltages not more than 10% above or below the nameplate voltage can handle normal loads. For heavy loads, however, the voltage at motor terminals must equal the voltage specified on nameplate.

### Overload Protection

Your saw features a reset overload relay button. If the motor stops running or fails to start (due to feed pressure too fast, dull blade or low voltage), turn switch "OFF", let the motor cool three to five minutes and push the reset button, which resets the overload device and allows you to turn the saw back on.

**WARNING: The ON/OFF switch should be in the off position, and the plug removed from the power source while the cool down takes place to prevent accidental starting when the reset button is pushed. Overheating may be caused by misaligned parts or dull blade, inspect your saw for proper setup before using it again.**

5. Most motor troubles may be traced to loose or incorrect connections, overload, low voltage (such as small size wire in the supply circuit) or to overly long supply circuit wire. Always check the connections, the load and the supply circuit whenever motor doesn't work well. Check wire sizes and length with the Wire Size Chart.

### Wire Size

**NOTE:** Make sure the proper extension cord is used and is in good condition.

The use of any extension cord will cause some loss of power. To keep this to a minimum and to prevent overheating and motor burnout, use the table to determine the minimum wire size (A.W.G.) extension cord.

#### Extension Cord Wire Sizes Required for 120V

Length	(A.W.G.)
0-25 Ft.	14
26-50 Ft.	12

## Table of Contents

Warranty.....	2	Mounting Table Saw to Workbench, Cabinet	
Safety Instructions for Table Saw.....	2-5	or Legset.....	17-18
Glossary of Terms for Woodworking.....	5-6	Getting to Know Your Table Saw.....	19-20
Motor Specifications & Electrical Requirements.....	6-7	Work Feed Devices.....	21
Power Supply and Motor Specifications.....	6	Push Stick.....	21
Double Insulation.....	6	Push Block.....	21-22
Polarized Plug.....	6	Auxiliary Fence.....	22
Motor Safety Protection.....	6	Safety Instructions for Basic Saw Operations.....	23-24
Overload Protection.....	7	Basic Saw Operations.....	25-32
Wire Size.....	7	Using the Miter Gauge.....	25
Unpacking and Checking Contents.....	8-9	Additional Safety Instructions for Crosscutting.....	25
Tools Needed.....	8	Crosscutting.....	25
Table of Loose Parts.....	8	Repetitive Crosscutting.....	26
List of Loose Parts.....	9	Miter Crosscutting.....	26
Assembly, Alignment and Adjustment.....	9-18	Bevel Crosscutting.....	26
Assembling Handle to Handwheel.....	9	Compound Miter Crosscutting.....	27
Blade Guard Assembly.....	10	Using the Rip Fence.....	27
Blade Guard Alignment.....	11	Additional Safety Instructions for Rip Cuts.....	27
Checking Anti-kickback Pawls.....	11	Ripping.....	28
Rip Fence Assembly and Adjustment.....	12	Bevel Ripping.....	29
Rip Fence Alignment.....	12	Using Featherboards for Thru-Sawing.....	30
Rip Fence Indicator Adjustment.....	13	Resawing.....	30
Miter Gauge and Indicator Adjustment.....	13	Using Featherboards for Non Thru-Sawing.....	31
On-Off Switch.....	13	Dadoing.....	31
Blade Tilting Control and Lock Lever Adjustment.....	14	Rabbeting.....	32
Adjusting 90 and 45 Degree Positive Stops.....	14	Ploughing and Molding.....	32
Adjusting Positive Stops at 90 Degrees.....	14	Installation and Operation of Molding Head.....	33
Adjusting Positive Stops at 45 Degrees.....	14	Maintaining Your Table Saw.....	33-34
Blade Tilt Indicator Adjustment.....	15	Maintenance.....	33
Checking Blade Parallel to Miter Gauge Groove.....	15	Lubrication.....	34
Adjusting Blade Parallel to Miter Gauge Groove.....	16	Sears Recommends the Following Accessories.....	34
Removing Sawblade.....	16	Troubleshooting.....	35
Installing Sawblade.....	17	Repair Parts.....	36-41

# Unpacking and Checking Contents

## Tools Needed

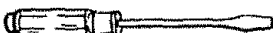
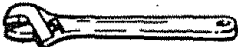
-  #2 Phillips Screwdriver
-  Medium Screwdriver
-  Adjustable Wrench

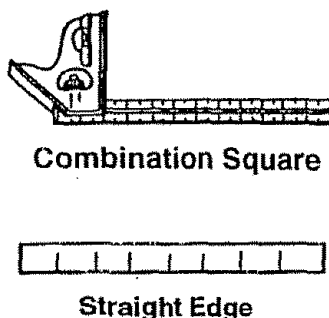

Combination Square must be true. Check its accuracy as shown below.

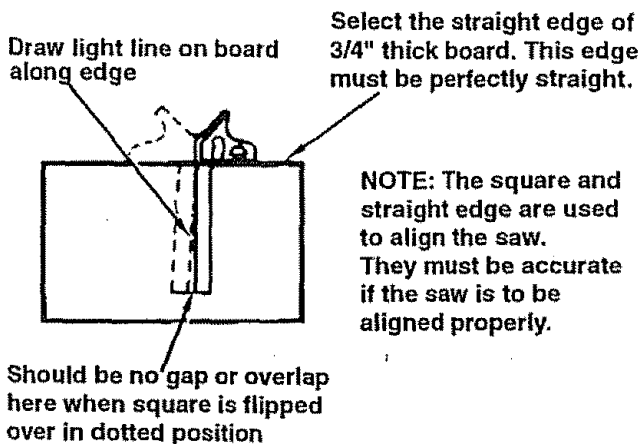

Separate all parts from packing material and check each one with the illustration and the list of Loose Parts to make certain all items are accounted for, before discarding any packing material.

**WARNING:** If any parts are missing, do not attempt to assemble the table saw, plug in the power cord or turn the switch on until the missing parts are obtained and are installed correctly.

Apply a coat of automobile wax to the table. Wipe all parts thoroughly with a clean, dry cloth. This will reduce friction when pushing workpiece.

**WARNING:** For your own safety, never connect plug to power source outlet until all assembly steps are complete, and you have read and understand the safety and operating instructions.

## Table of Loose Parts

Item	Description	Qty
A	Table Saw Assembly.....	1
B	Miter Gauge.....	1
C	Blade Guard and Spreader.....	1
D	Rip Fence (Without Handle).....	1
E	Owner's Manual.....	1
F	Bag of Loose Parts.....	*

\*Number varies; bags can contain other smaller bags.

Loose parts within a bag may be pre-assembled at factory to ensure proper contents. The parts may need to be disassembled when checking the contents against the loose parts list.

**NOTE:** To make assembly easier keep contents of each bag together and separate from contents of other bags.

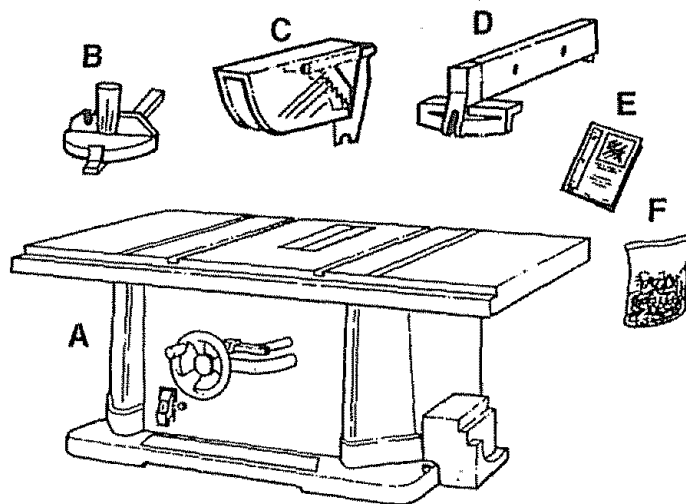



## List of Loose Parts in the Box and Bags

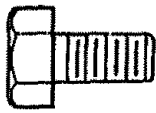

Hex Screw - 1/4-20 x 1/2" (2)



Carriage Bolt - 1/4-20 x 7/8" (1)

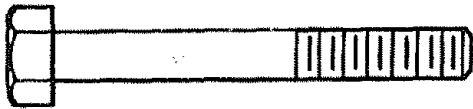

Hex Screw - 1/4-20 x 2-1/8" (1)



Flat Washer (1)



1/4" External Lockwasher (4)



Nut Hex 5/16-18 (1)



Wing Nut 1/4-20 (1)

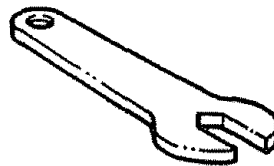

Shaft Wrench (1)

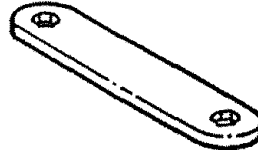

Arbor Wrench (1)

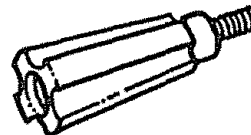

Handle (Rip Fence) (1)

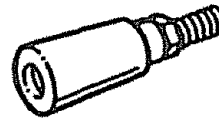

Knob (Handwheel) (1)

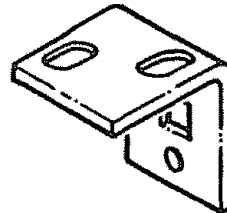

Spreader Bracket Assembly (1)

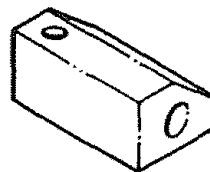

Spreader Support (1)

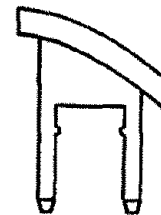

Switch Key (1)

## Assembling Handle to Handwheel

1. Thread screw into tapped hole in handwheel, as shown.
2. When properly assembled, the knob will rotate freely with only a small amount of play.

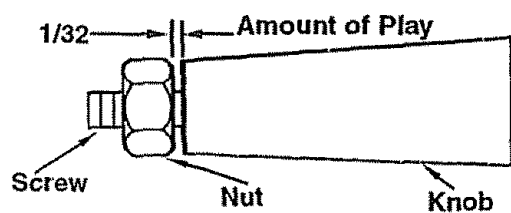

3. Lock nut against handwheel.

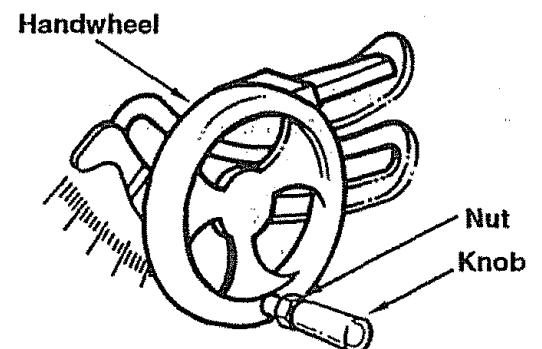

# Blade Guard Assembly

1. From among the loose parts, locate the following hardware:

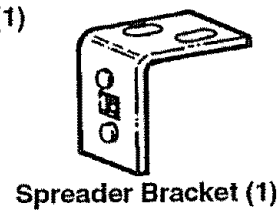
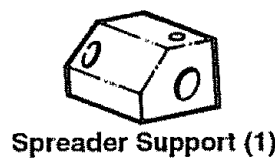
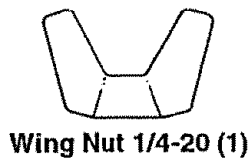
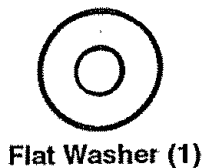
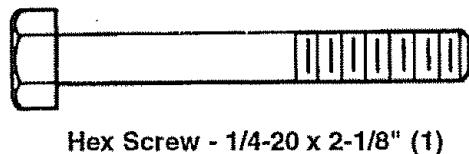
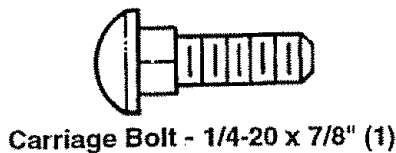
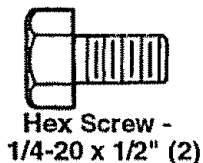

2. Position large recessed shoulder end of the spreader support against end of pivot rod and fasten to table using the 1/4-20x2-1/8" long hex screw and 1/4" external tooth lockwasher.

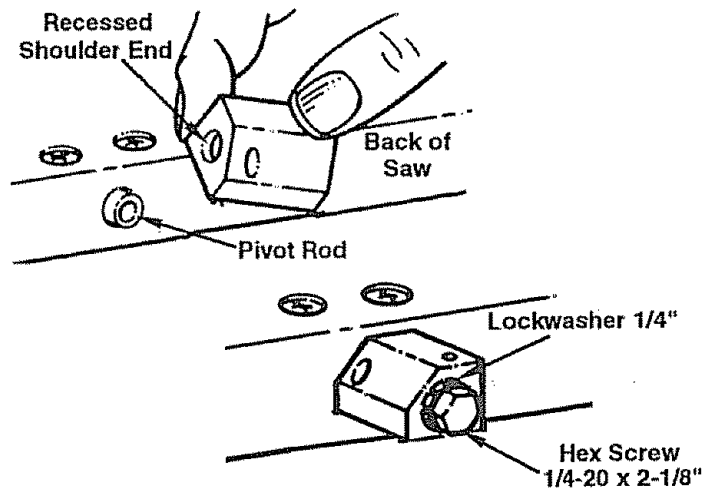

3. Position the spreader bracket to the spreader support as shown. The 1/4-20x1/2" screws and lockwashers are to be assembled finger tight only at this time.

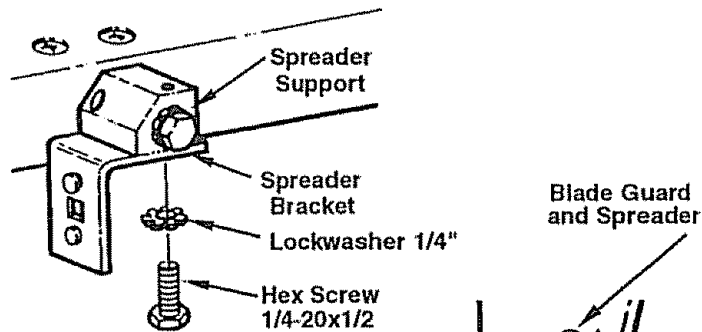

4. Insert the 1/4-20 x 7/8" carriage bolt in the square feature of the spreader bracket as shown. Assemble the flat washer first, then the 1/4 external lockwasher and the 1/4-20 wing nut on the carriage bolt leaving the wing nut loose at this time.

5. Attach blade guard and spreader by positioning the open slot in the spreader directly above the spreader bracket. Slide the spreader down between the spreader bracket and the head of the rivet until either the open slot sets on the rivet or the spreader sets on the table top surface. **Tighten wing nut.**

**NOTE:** Both washers must be positioned between the spreader and the wing nut.

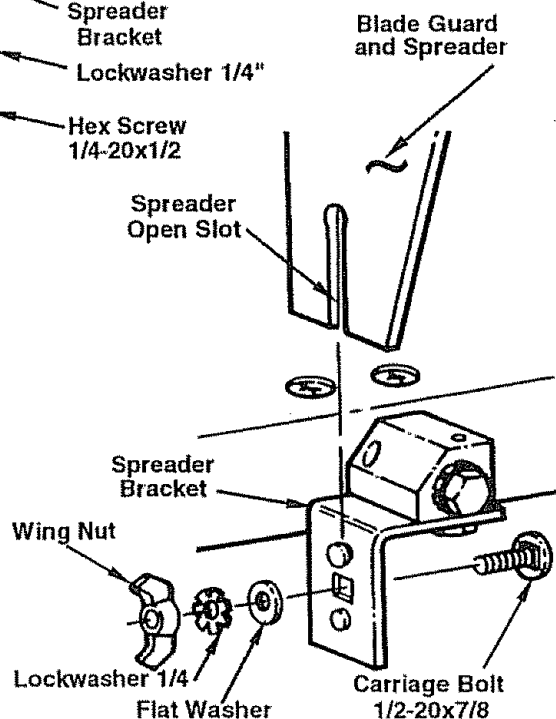

## Blade Guard Alignment

**IMPORTANT:** To work properly, the spreader must always be adjusted so the cut workpiece will pass on either side of the spreader without binding or skewing to the side.

**NOTE:** The spreader is thinner than the width of the KERF by approximately six thicknesses of newspaper.

To check if alignment is proper, slide 3 thicknesses of newspaper between straight edge and spreader.

Readjust if necessary.

1. Make two folds in a small piece (6" x 6") of ordinary newspaper making three thicknesses. The folded paper will be used as a "spacing gauge".
2. Raise blade to maximum height and make sure blade is in vertical position (straight up and down) or at "0°" blade angle.
3. Lay a piece of straight flat wood or straight edge against the sawblade. Insert folded paper between spreader and wood strip.
4. Make sure the three hex screws are loose enough to slide spreader bracket and to rotate spreader support.
5. Lift the anti-kickback pawl to clear the wood or straight edge and hold the spreader tightly against the paper and wood. Make sure the wood is against the sawblade. Tighten the three hex screws.

This will align the spreader in the middle of the cut (KERF) made by sawblade.

**NOTE:** To remove the guard for non-through cuts, loosen the wing nut and slide the guard upward off the spreader bracket. Do not disturb the setting of the spreader support bracket.

When replacing the guard, slide the spreader down onto the spreader support bracket. Make sure the wing nut is tightened securely. This lets you remove and replace the guard without disturbing the spreader alignment.

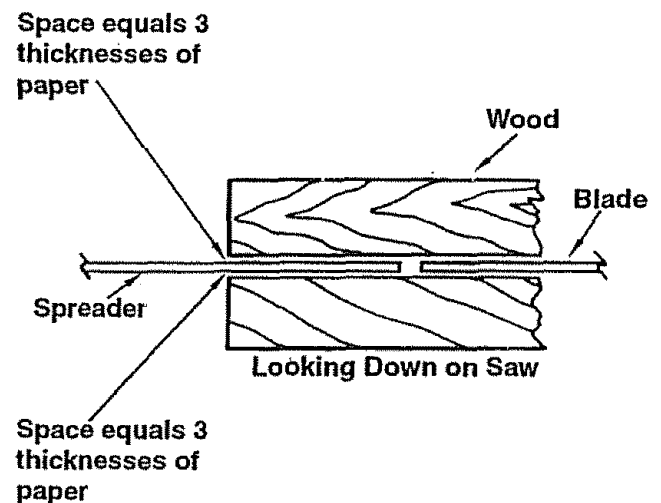
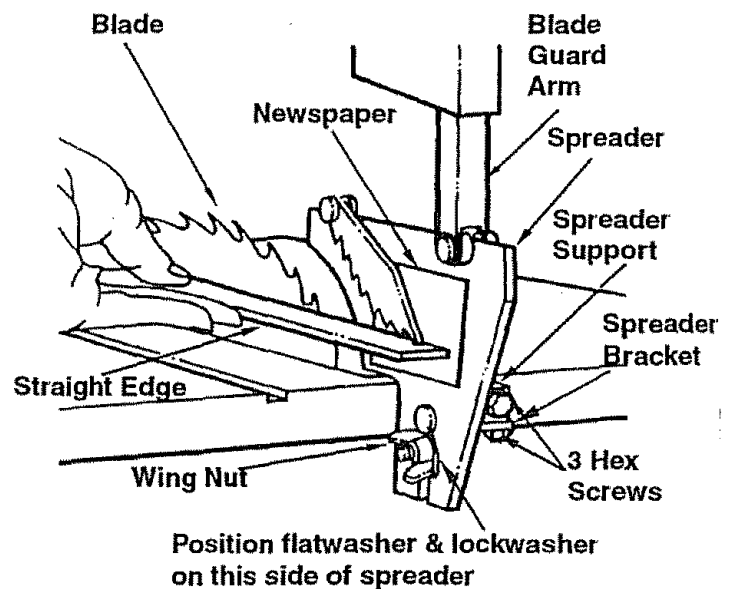

## Checking Anti-kickback Pawls

1. Raise blade guard up to upright position.
2. Rotate both pawls up toward rear of spreader. Let pawls go to make sure they return freely by spring force to their normal position.
3. Slide a sample workpiece under a pawl and pull it toward the front of the saw. Repeat for both pawls.
4. The anti-kickback pawl should prevent the workpiece from moving toward the front of the saw.
5. See page 33 for instructions on how to sharpen the teeth of the anti-kickback pawls.

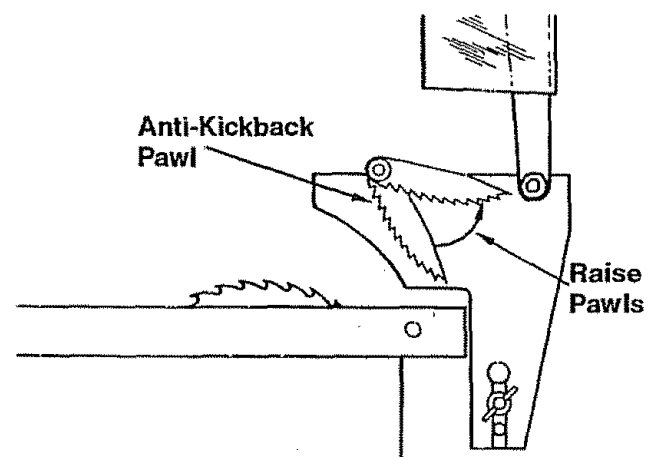

## Rip Fence Assembly and Adjustment

**WARNING:** To prevent personal injury, always disconnect plug from power source when making adjustments.

1. Thread 5/16-18 nut all the way onto the fence locking handle.
2. Thread rip fence locking handle into cam until tight. Lock the nut against cam with wrench.
3. Place the rip fence on the table and lower the rip fence locking handle until the rip fence is secure to front rail.
4. Check to see if rear clamp on the rip fence is loose. If not, turn the rip fence adjustment screw counterclockwise until the rear clamp on the rip fence is loose with the fence assembly locked to the front rail.
5. With fence assembly locked to front rail, turn the rip fence adjustment screw clockwise until rear clamp is snug.
6. Raise the rip fence locking handle.
7. Turn the rip fence adjustment screw clockwise an additional 1/2 turn.
8. Check the rip fence by applying moderate side pressure to the rear of the fence assembly. If the rip fence deflects easily raise the rip fence locking handle and turn the rip fence adjustment screw clockwise another 1/4 turn.
9. Check rip fence again by applying moderate side pressure to the rear of the fence assembly. If necessary repeat step 8 until rip fence is secure.

**NOTE:** Overtightening the rip fence adjustment screw may cause the rip fence to be loose on the front table rail.



Nut Hex 5/16-18 (1)

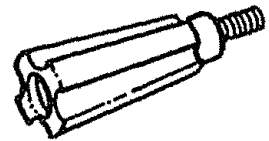

Handle (Rip Fence) (1)

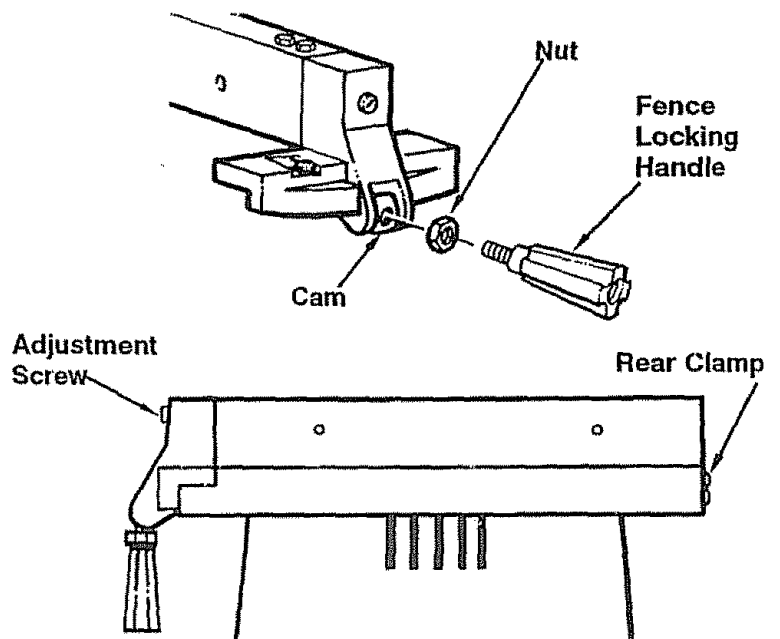

## Rip Fence Alignment

**WARNING:** To prevent personal injury, always disconnect plug from power source when making adjustments.

**CAUTION:** The rip fence must be aligned parallel to the blade to minimize the danger of kickback. For convenience, the rip fence will be aligned parallel to the miter gauge slot. The sawblade will be set or adjusted parallel to the slot later.

1. Place the rip fence on the right side of the table adjacent to the miter gauge groove.
2. Lower the rip fence locking handle to secure the rip fence.
3. Check to see that the edge of the rip fence is parallel with the miter gauge groove.
4. If the rip fence is not parallel:
  - Raise the rip fence locking handle.
  - Loosen the two hex head screws located on top of the rip fence.
  - Align the rip fence parallel to the miter gauge groove.
  - Lower the rip fence locking handle.
  - Tighten the two hex head screws previously loosened.

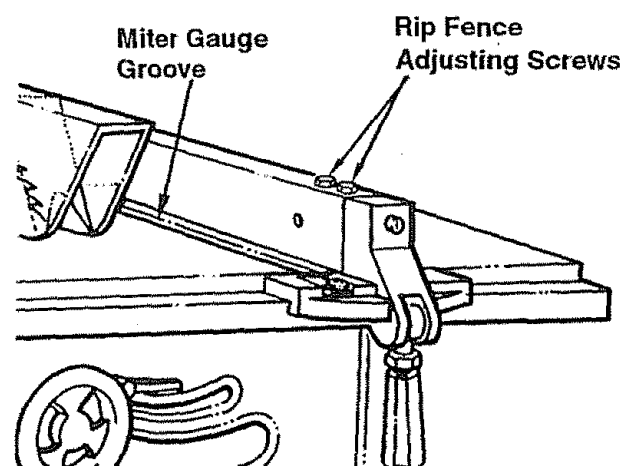

- Raise the rip fence locking handle, move and return the rip fence adjacent to the miter gauge groove, lower the rip fence locking handle.
- Repeat and recheck steps 8 and 9 in the "Rip Fence Assembly and Adjustment" section.
- The rip fence should now be parallel to the miter gauge groove. If not, repeat steps and recheck.

**NOTE:** To always obtain the best alignment of the rip fence, develop the habit of holding the front casting on the fence back against the table top while tightening the fence lock handle. Tighten the rip fence lock handle securely to prevent rip fence movement while sawing.

## Rip Fence Indicator Adjustment

With the rip fence locked to the table, measure the distance from the side of the rip fence to the nearest side of the blade. The indicator should point to the same marking on the scale. If it does not, loosen the screw holding the indicator, move the indicator to the correct marking on the scale and tighten the screw.

**HINT:** The rip fence indicator will need to be readjusted whenever a thicker or thinner blade is installed. When making critical cuts, make a trial cut on scrap wood rather than relying on the rip scales.

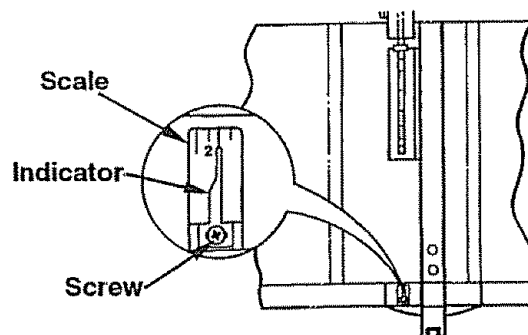

## Miter Gauge and Indicator Adjustment

1. Check to make sure the miter gauge will slide freely through both entire table grooves before using it.
2. To adjust the miter gauge, loosen lock knob and set the miter gauge body so the scale is at the 90° mark, then tighten lock knob.
3. Make a cut on a piece of scrap wood. Check it with a square to see if the piece of wood was cut at 90°. If the piece was not cut 90°, adjust the miter gauge body, tighten lock knob and make additional cuts until you are certain you have made a 90° cut.
4. Loosen the miter scale adjustment screw, set the indicator point on the 90° mark on the scale and tighten screw.

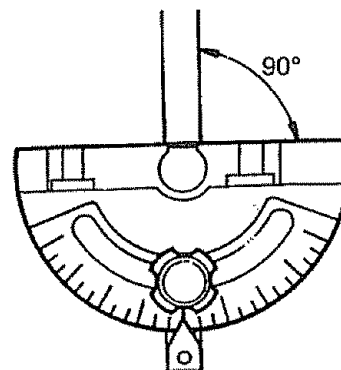

## On-Off Switch

**CAUTION:** Before turning switch "ON", make sure the blade guard is correctly installed and operating properly.

The On-Off switch has a locking feature. This feature is intended to prevent unauthorized and possible hazardous use by children and others.

1. Insert key into switch.
2. To turn saw "ON", stand to either side of the blade, never in line with it; insert finger under switch lever and pull end of lever out.
  - After turning switch "ON", always allow the blade to come up to full speed before cutting.
  - Do not cycle the motor switch on and off rapidly as this may cause the sawblade to loosen. In the event this should ever occur, allow the sawblade to come to a complete stop, unplug saw and retighten the arbor nut normally, not excessively.
  - Never leave the saw while the power is "ON".
3. To turn saw "OFF", push lever in. Never leave the saw until the cutting tool has come to a complete stop.
4. To lock switch in "OFF" position, hold switch in with one hand and remove key with the other hand.

**WARNING:** For your own safety, lower blade or other cutting tool below table surface. (If blade is tilted, return it to vertical, 90° position). Always lock the switch "OFF". When saw is not in use, remove key and keep it in a safe place. Also, in the event of a power failure (all of your lights go out) turn switch off and lock it by removing the key. This will prevent the saw from starting up again when the power comes back on.

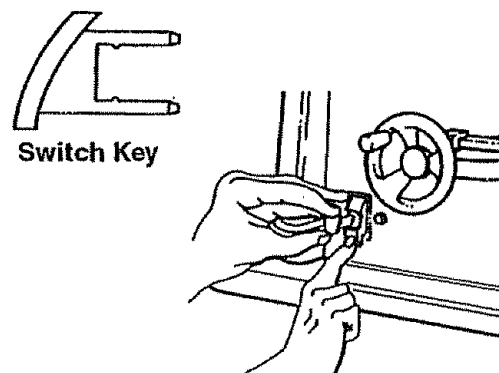

## Blade Tilting Control and Lock Lever Adjustment

1. Loosen blade tilting lock lever and slide the elevation handwheel until blade is at desired angle and tighten blade tilt lock lever.
2. If blade lock lever interferes with some object before blade tilting control mechanism is held tight or rigid, pull lock lever out and rotate lock lever counterclockwise to another position. Tighten lock lever. Recheck for proper adjustment of blade tilt lock lever.
3. If lock lever won't loosen enough so blade can be tilted, pull lock lever out and rotate lever clockwise to another position. Tighten blade lock lever.

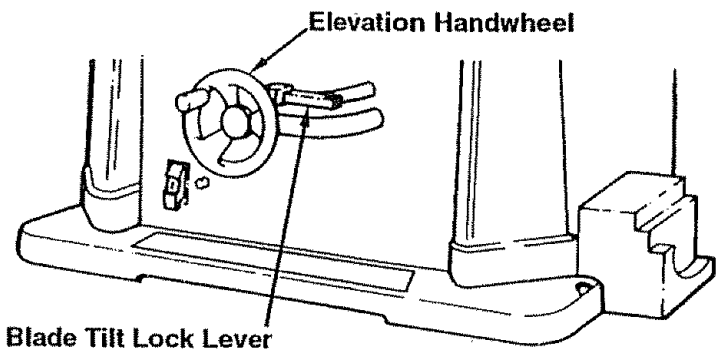

## Adjusting 90 and 45 Degree Positive Stops

Your saw is equipped with positive stops for fast and accurate positioning of the sawblade at 90 and 45 degrees to the table. Always measure blade position from the left side of the blade. Blade insert may not be flush with table top.

**WARNING:** To prevent personal injury, always disconnect plug from power source when making adjustments.

### Adjusting Positive Stop at 90 Degrees

1. Unplug the saw.
2. Turn elevation wheel clockwise and raise blade to maximum height.
3. Loosen the blade tilt lock lever and push the elevation wheel to the left as far as possible and tighten the blade tilt lock lever.
4. Place a combination square on the table with one end of square against the blade as shown and check to see if the blade is 90° to the table.
5. If the blade is not 90° to the table, loosen the blade tilt lock lever, loosen 90° adjustment screw (A) a few turns and push the elevation wheel until the blade is 90° to the table.
6. Tighten blade tilt lock lever and tighten 90° adjustment screw until it stops.

### Adjusting Positive Stop at 45 Degrees

1. Loosen the blade tilt lock lever and push elevation wheel to the right as far as possible and tighten the blade tilt lock lever.
2. Place a combination square on the table with one end of the square against the table as shown, and check to see if the blade is 45° to the table.
3. If the blade is not 45° to the table, loosen the blade tilt lock lever, loosen 45° adjustment screw (B) a few turns and push the elevation wheel until the blade is 45° to the table.
4. Tighten blade tilt lock lever and tighten 45° adjustment screw until it stops.

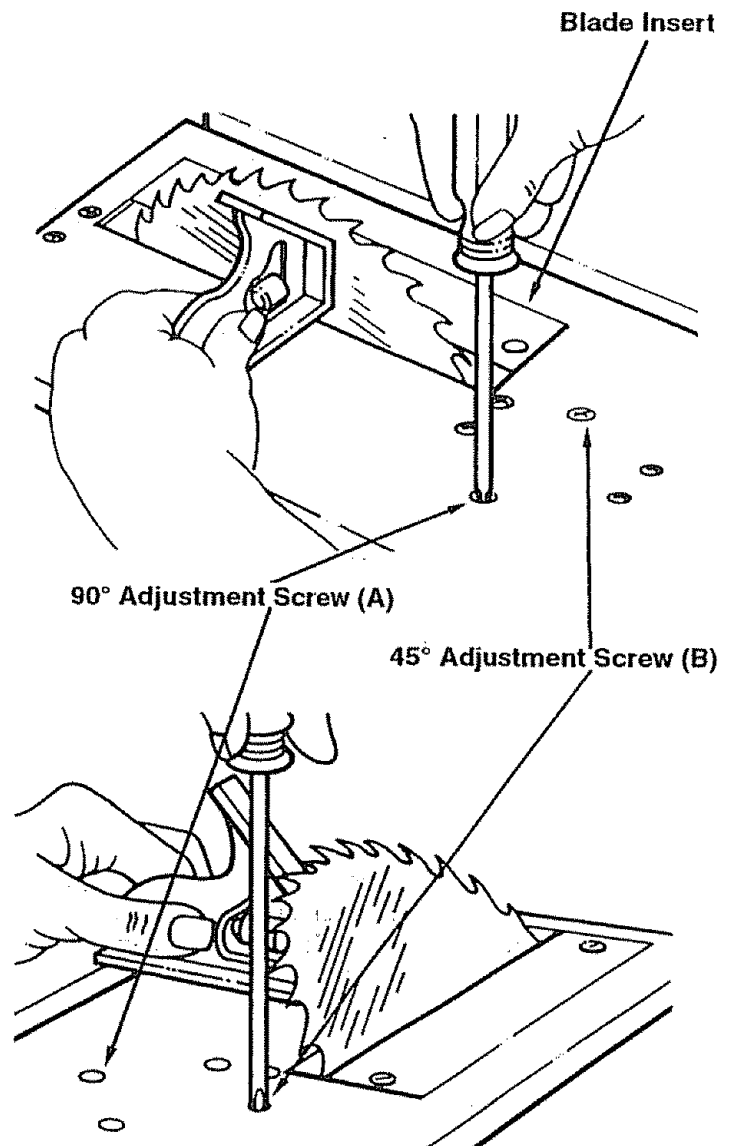

## Blade Tilt Indicator Adjustment

1. With 90° positive stop set and blade tilt control pushed against this stop, loosen indicator screw, adjust indicator pointer to "0" degrees and retighten indicator screw.

**NOTE:** When making critical cuts, make a trial cut on scrap wood rather than relying on the tilt scale or stops.

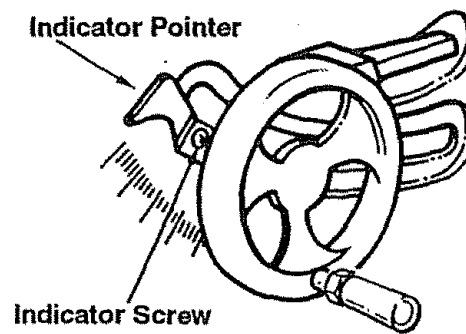

## Checking Blade Parallel to the Miter Gauge Groove

**WARNING:** To avoid injury from accidental start, make sure switch is "OFF" and plug is not connected to power source outlet.

The blade was adjusted parallel to the miter gauge groove at the factory. In order to insure accurate cuts and help prevent kickback, this adjustment should be rechecked. If adjustment is necessary follow the steps below.

**WARNING:** If the sawblade is NOT parallel with the miter gauge groove, it is said to have "HEEL". This condition can cause the workpiece to bind or move away from the rip fence at the end of a rip cut, possibly causing a kickback.

1. Unplug saw.
2. Turn elevation wheel and raise blade as high as it will go.
3. Lift blade guard if already installed, to its highest position.
4. Select a tooth on the front of sawblade that is set to the right when viewing blade from the front of the saw, and mark this tooth with a pencil.
5. Place the base of a combination square against the left edge of the right miter gauge groove, and extend the sliding rule of square so it just touches the marked tooth.
6. Rotate blade and check the same marked blade tooth at the rear of the saw table.
7. If the front and back measurements are not identical, the mechanism must be adjusted to make the blade PARALLEL to miter gauge groove.

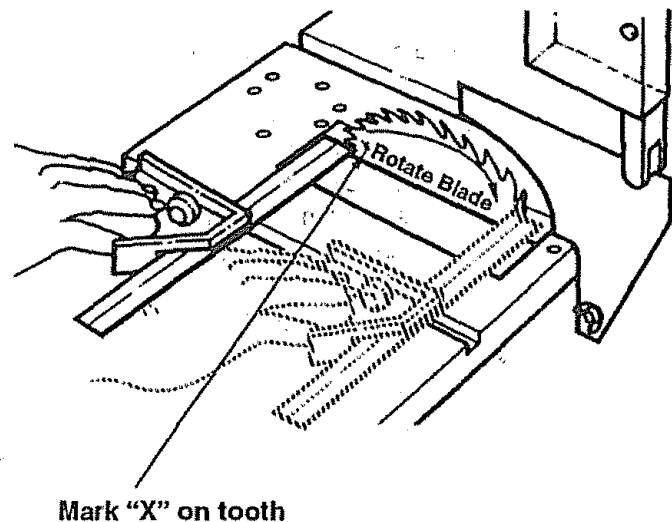

## Adjusting Blade Parallel to Miter Gauge Groove

**WARNING:** To avoid injury from accidental start, make sure switch is "OFF" and plug is not connected to power source outlet.

**CAUTION:** Fold a piece of cardboard over the blade to protect your hand.

1. Unplug the saw.

**NOTE:** Always review the section "Checking Blade Parallel to the Miter Gauge Groove" before proceeding with this section.

2. Loosen 1/2 turn the four alignment screws (A) in the top of table next to the sawblade. This will allow the mechanism below the table to be shifted sideways.

3. Fold a piece of cardboard over the blade to protect your hands.

4. Grasp the blade and the spreader support mechanism and move it to either the right or left a small amount as needed to make the square touch the same amount front and rear. Tighten one screw.

5. Check with square to determine if marked tooth touches square by the same amount at front and rear. If it does, alternately tighten the other three screws slowly.

If it does not, loosen screws and move blade the required amount.

**NOTE:** If adjustment cannot be achieved by loosening the four alignment screws (A), loosen the two secondary alignment screws (B) only if it is absolutely necessary to make this adjustment.

6. Recheck blade clearance to table and table insert to make sure blade does not hit at both 90 and 45 degree blade tilt.

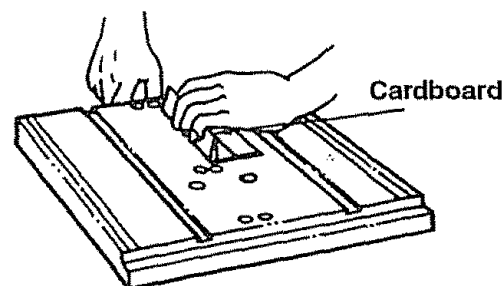
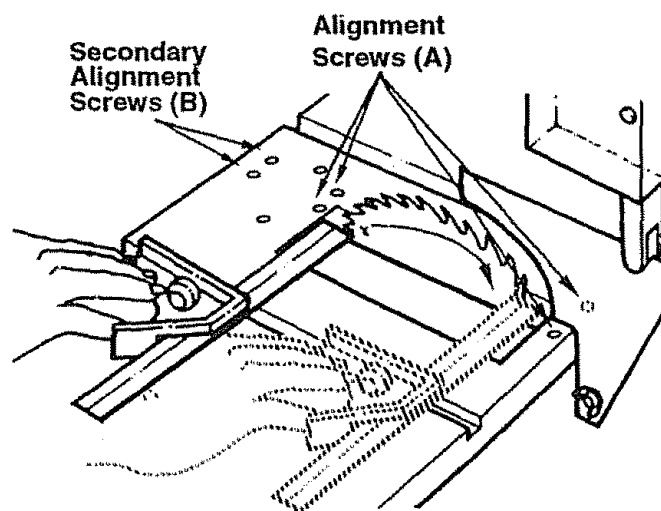

## Removing Sawblade

**WARNING:** To avoid injury from accidental start, make sure switch is "OFF" and plug is not connected to power source outlet.

1. Unplug the saw.

2. Remove blade guard and retain hardware.

3. Remove the phillips head screws from the blade insert.

4. Lift the blade insert noting that the formed edge is toward the blade. Set insert aside.

5. Turn elevation handwheel clockwise to raise sawblade as high as it will go.

6. Insert open end arbor shaft wrench over flat portions of motor spacer and closed end arbor nut wrench over arbor nut. Position wrenches as shown, holding your hands well above blade.

7. Hold arbor wrench against table and loosen arbor nut with arbor nut wrench by pulling it forward to you.

8. Slide sawblade off motor shaft.

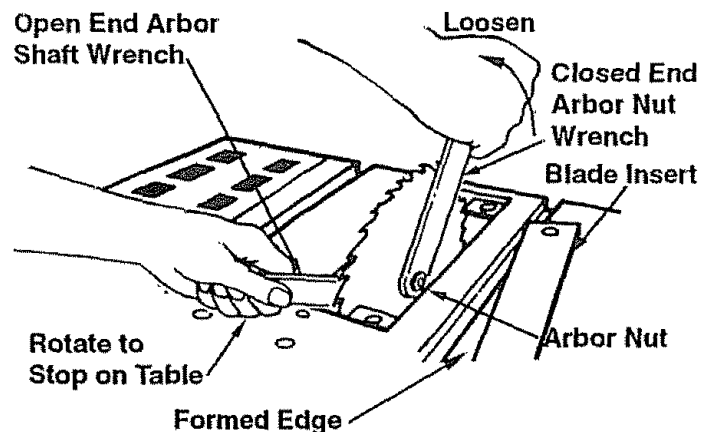



## Installing Sawblade

1. Unplug the saw.
  2. Install sawblade onto shaft with the top blade teeth pointing toward front of saw.
  3. Install blade collar with hollow surface toward blade.
  4. Install arbor nut.
  5. To tighten arbor nut, hold arbor wrench against rear of table, push arbor nut wrench towards rear of table.
- NOTE:** Arbor nut should just be snug. Do not over-tighten.
6. Install blade insert in the table recess with its formed edge toward the blade.
  7. Insert screws through front and rear holes and tighten.
- IMPORTANT:** Do not attempt to run saw without blade collar properly installed.

**WARNING:** To avoid injury from a thrown workpiece, blade parts, or blade contact, never operate saw without the proper insert in place. Use the sawblade insert when sawing. Use the dado/molding head insert when using a dado or molding head. See page 32 for Sears recommended accessories.

8. Re-install blade guard and tighten wingnut.

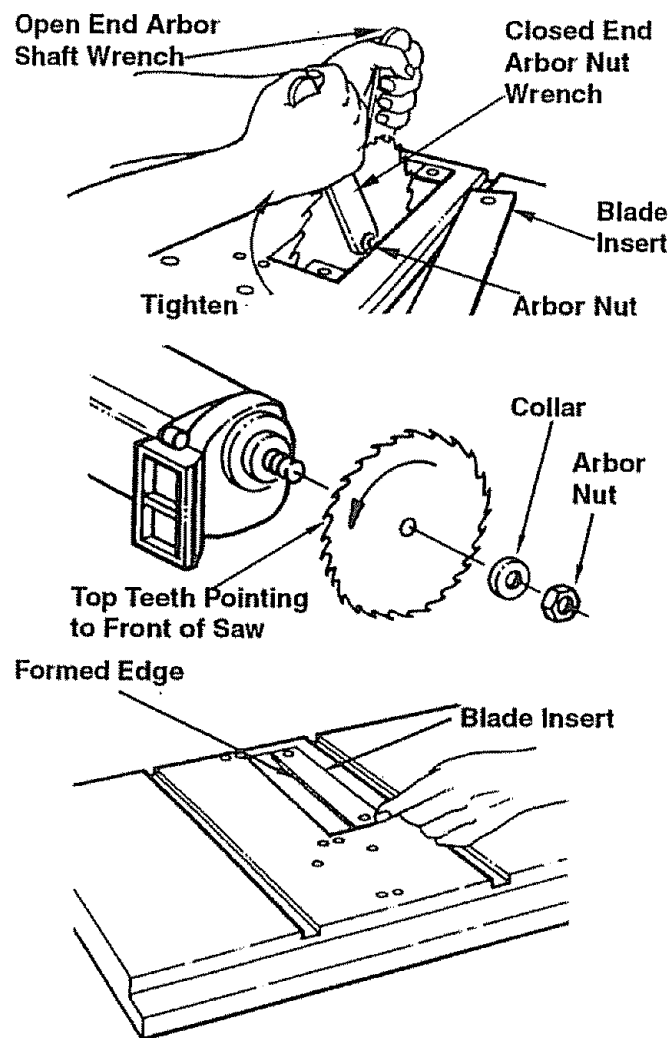

## Mounting Table Saw to Workbench, Cabinet or Legset

**WARNING:** To avoid injury from accidental start, make sure switch is "OFF" and plug is not connected to power source outlet.

**WARNING:** To avoid injury from kickback or saw movement the saw must be properly secured to a sturdy workbench, cabinet or legset. Casters if provided on the cabinet or legset must be locked during saw operation. If there is any tendency for the saw to move or rock during operation, this must be corrected immediately.

If table saw is to be used in a permanent location, it should be fastened securely to a firm supporting surface such as a workbench, cabinet or legset using the four mounting holes.

### Workbench Mounting Using Hardware

When mounting table saw to a workbench and using a vacuum hookup, holes should be drilled through the supporting surface of the workbench using the dimensions illustrated.

When mounting table saw without a vacuum hookup to the base, an opening must be made in the workbench using the dimensions illustrated, so the sawdust can fall away from the saw base area.

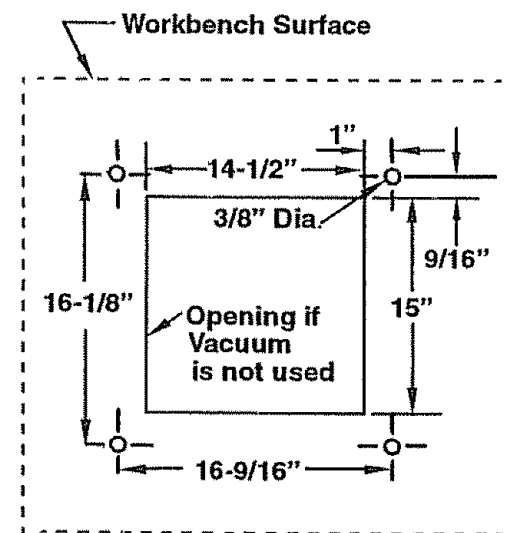

(Front of Table Saw)  
Diagram of Workbench Mounting Holes

# Mounting Table Saw to Workbench, Cabinet or Legset (continued)

## Workbench Mounting Using "C" Clamps

An alternative method of securing your table saw is to fasten the saw base with "C" clamps.

1. Follow instructions for mounting to workbench, substituting "C" clamps in each recessed mounting screw location.
2. Securely clamp saw to workbench using three or four "C" clamps, as shown.

Supporting surface where saw is to be mounted should be examined carefully after mounting to insure that no movement can occur during use. If any tipping, sliding or walking is noted, secure the workbench or cabinet before operating the table saw.

## Cabinet or Legset Mounting Using Hardware

When mounting table saw to a cabinet or legset and using a vacuum hookup, holes should be drilled through a 3/4" thick plywood base using the dimensions illustrated.

When mounting table saw without a vacuum hookup to the base, an opening must be made in the plywood base using the dimensions illustrated, so the sawdust can fall away from the saw base area.

**WARNING: Never clamp the table saw directly to a legset. The saw could fall. You could be badly cut.**

## Table Saw Mounting and Assembly Procedures

1. Locate the proper hole mounting diagram for your desired type of table saw mounting.
2. Mark the hole locations and cutout opening if vacuum is not used. Drill the holes and cutout the area to allow sawdust to fall away from the base if a vacuum is not being utilized.
3. Place the table saw on the mounting surface and align the four holes.
4. Insert four (4) 1/4-20 screws that are long enough for washers and nuts which will properly secure the table saw to the mounting surface.

## Table Saw Mounting to Legset Accessory, Cat. No. 9-22235

1. Be sure to mount the table saw to the 3/4" thick plywood base for mounting table saw to legset as shown in the previous diagram.
2. Assemble legs and stiffeners per legset 9-22235 instructions using the hole pattern marked "B" in the side stiffeners.
3. Place the table saw with plywood base on legset and align the four holes.
4. Insert four (4) 1/4-20 screws that are long enough for washers and nuts which will properly secure the table saw to the legset. Tighten hardware.

When using a table extension on any side of the saw, bolt the saw to a stationary surface or prop up the outer end of the extension from the floor or bench top to keep the saw from tipping.

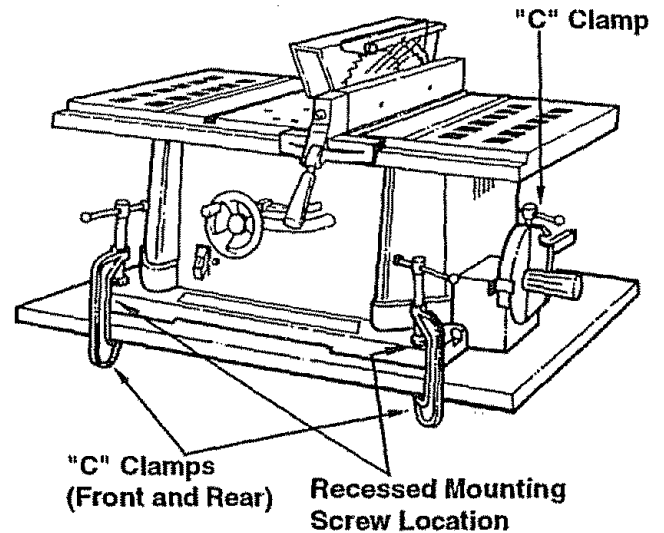

Diagram of Clamping Table Saw to Workbench

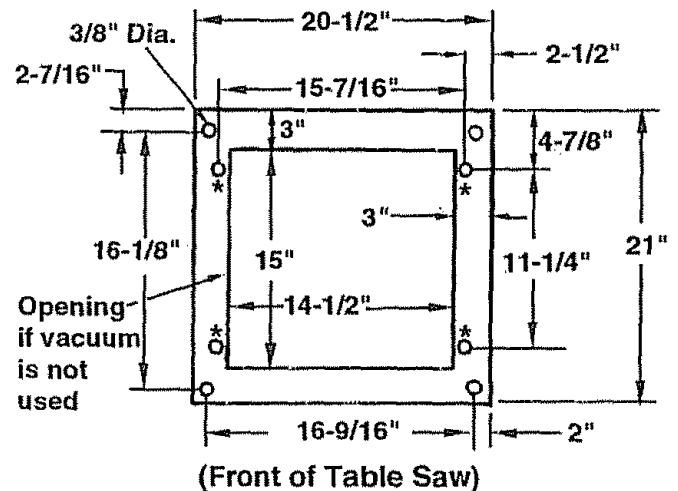
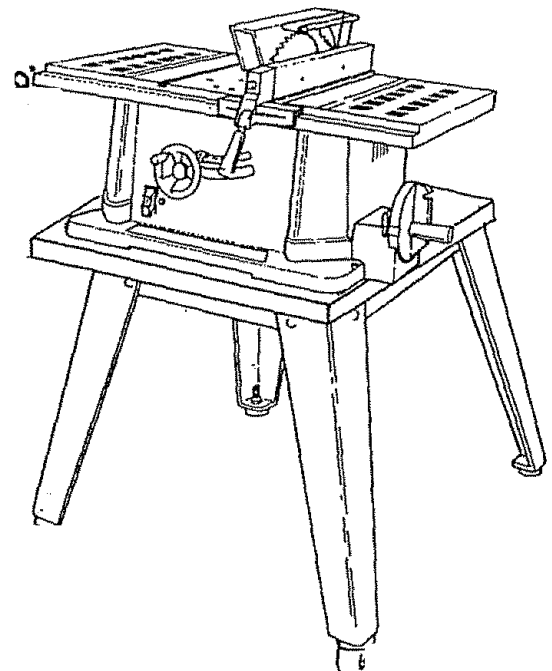
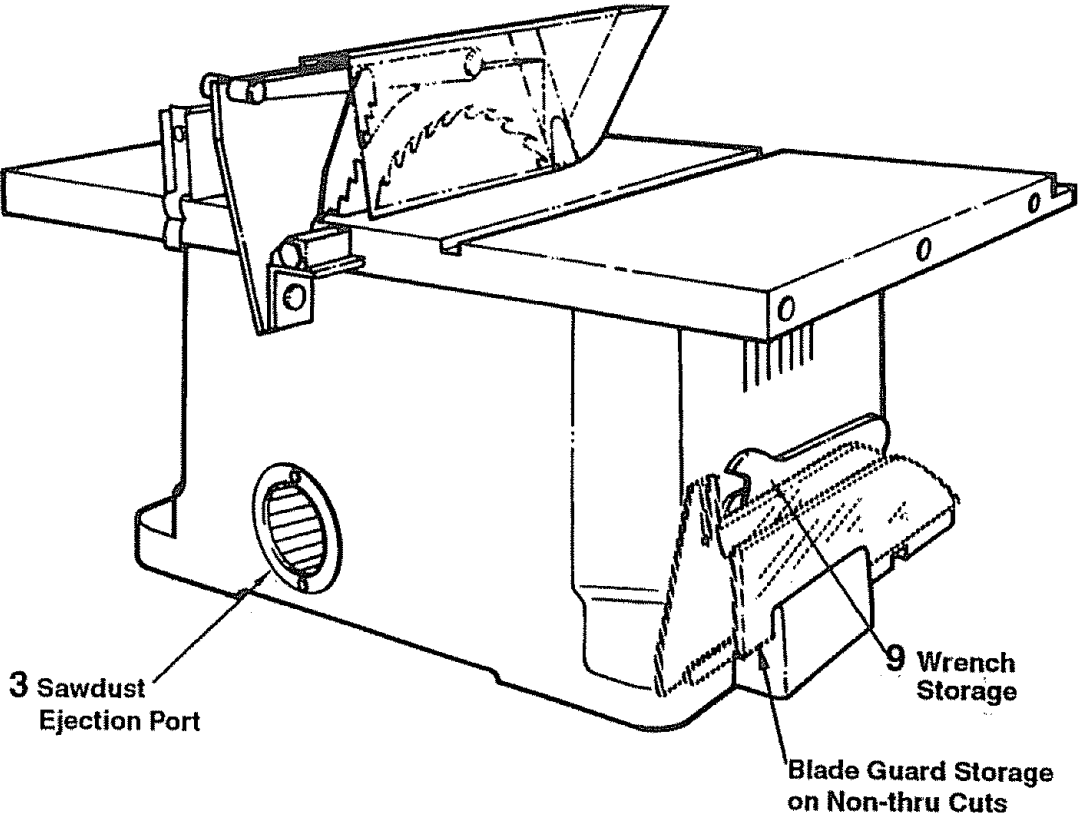
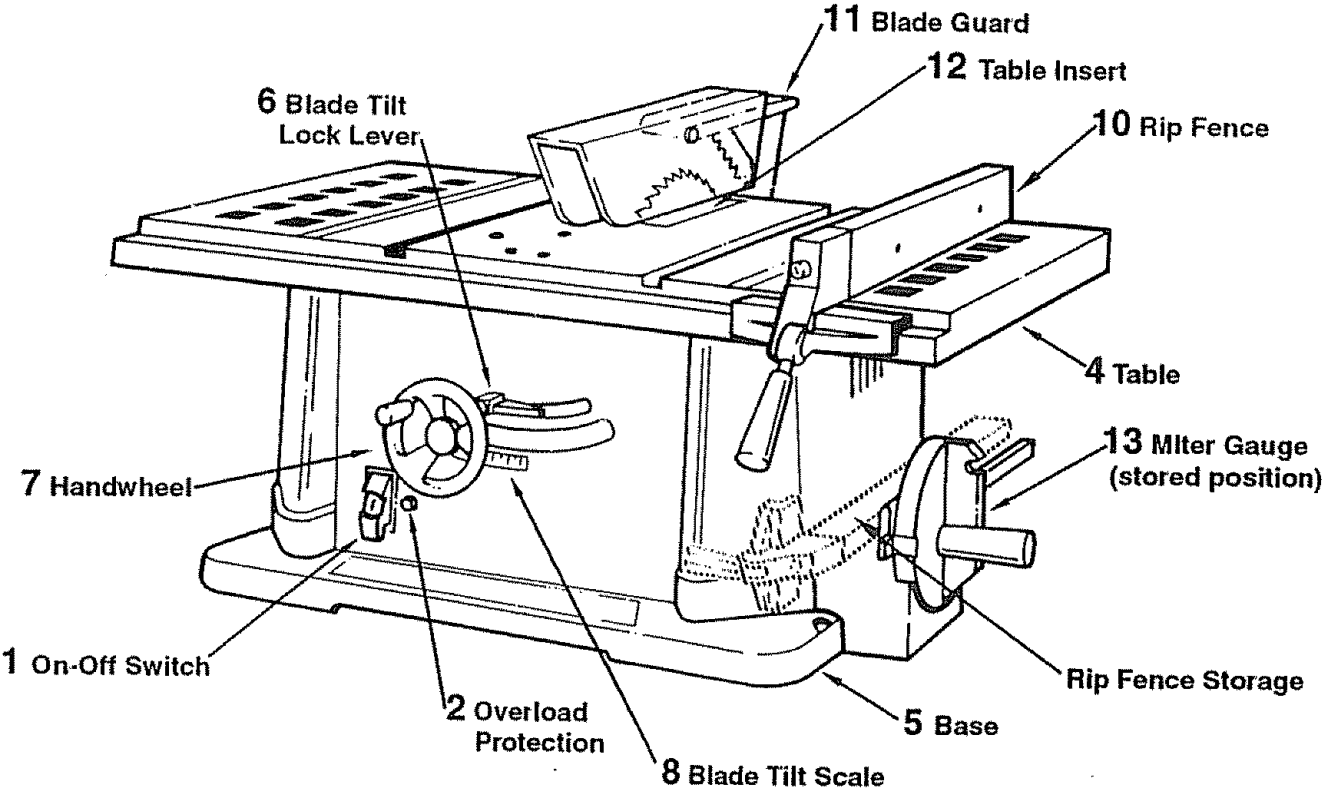

Diagram of Cabinet or Legset Mounting Holes  
\*These holes used for legset 9-22235



# Getting to Know Your Table Saw



# Getting to Know Your Table Saw (continued)

## 1. On-Off Switch.

**CAUTION:** Before turning switch "ON", make sure the blade guard is correctly installed and operating properly.

The On-Off Switch has a locking feature. This feature is intended to help prevent unauthorized and possible hazardous use by children and others.

## 2. Overload Protection

Your saw features an overload relay reset button. If the motor stops running or fails to start (due to feed pressure too fast, dull blade or low voltage), turn switch "OFF". Unplug the saw. Let the motor cool three to five minutes and push the reset button, which resets the overloaded device and allows you to turn the saw back on.

**WARNING:** The on/off switch should be in the off position, and the plug removed from the power source while the cool down takes place to prevent accidental starting when the reset button is pushed.

## 3. Sawdust Ejection Port

Your table saw is equipped with a vacuum hookup. This feature will allow you to attach any standard 2-1/2 inch diameter wet/dry vacuum hose into the hole provided for convenient sawdust removal.

**WARNING:** Sawdust can clog motor. Motor could ignite sawdust. Even if saw is connected to vacuum, blow out sawdust regularly.

## 4. Table

Provides large working surface to support workpiece.

## 5. Base

Supports table. For additional stability, holes are provided in base to bolt the saw to a workbench or stand.

## 6. Blade Tilt Lock Lever

Clamps the tilt mechanism after the blade is adjusted to desired position. Use handwheel as a lever to tilt blade.

## 7. Handwheel

Elevates or lowers the blade. Also used as a lever to tilt the blade from 0 to 45 degrees.

## 8. Blade Tilt Scale

Shows the degree the blade is tilted.

## 9. Wrench Storage

Conveniently stores shaft and arbor nut wrenches.

## 10. Rip Fence

Exclusive self-aligning, quick-set rip fence can be easily moved or locked in place by simply raising or lowering lock handle. Holes are provided in the rip fence for attaching a wood facing.

Select a piece of smooth straight wood approximately 3/4 inch thick, at least as long as the rip fence, and at least 7-1/2" wide (high) to permit clamping of featherboards.

Attach it to the fence with two round head #10 wood screws 1-5/8" long.

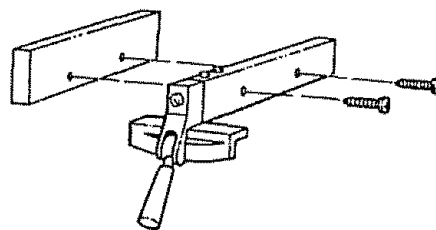

**WARNING:** When positioning fence for maximum rip, make sure end of fence head is even with the edge of the table. Fence cannot be locked securely beyond the edge of the table. The workpiece could bind and kickback.

## 11. Blade Guard

Use the sawblade guard, spreader and anti-kickback pawls for any thru-sawing (whenever the blade comes through the top of the workpiece). Make sure the anti-kickback pawls work properly. Make sure the spreader is in line with sawblade. (See page 10-11)

To remove the guard for special operation, loosen wing nut and slide the spreader up. Do not disturb the setting of the spreader bracket.

When replacing the guard, slide spreader down over the spreader bracket. Hand tighten wing nut securely.

## 12. Table Insert

Is removable for removing or installing blade or other cutting tools.

**WARNING:** For your own safety turn switch "OFF" and remove plug from power source before removing insert.

To remove the insert.

- Lower the blade below the table surface.
- Raise blade guard.
- Remove insert screws and lift insert from pocket in table.

**WARNING:** To avoid injury from a thrown workpiece, blade parts, or blade contact, never operate saw without the proper insert in place. Use the sawblade insert when sawing. Use the dado/molding head insert when using a dado blade or molding head.

## 13. Miter Gauge

Head can be locked in desired position for cross cutting or mitering by tightening the lock knob. Always securely lock it when in use.

Notches are provided in the miter gauge for attaching an auxiliary facing to make it easier to cut longer pieces. Be sure facing does not interfere with the proper operation of the sawblade guard.



Select a suitable piece of smooth straight wood, drill two holes through it and attach it with screws.

**NOTE:** When bevel crosscutting, attach facing so that it extends to the right of the miter gauge and use the miter gauge in the groove to the right of the blade.

# Work Feed Devices

Before cutting any wood on your saw, study all of the "Basic Saw Operations" found on pages 23 through 33

As you learn new table saw woodworking techniques you'll see that many types of cuts need different support and feeding devices, known as jigs or fixtures. They can help you make cuts more accurately. By helping to steady the workpiece and keep you away from the blade, they can help you safely use your saw for certain cuts.

Many people custom build their own jigs and fixtures. Jigs and fixtures are often designed for a particular cut.

You can use your table saw to easily make many jigs and fixtures. To get you started, we've included instructions for some simple ones. After you have made a few practice cuts, make up these jigs before starting any projects. Make the push stick first.

## Push Stick

Make the push stick using a piece of 1 x 2

## Push Block

There are any number of ways to properly cut your workpieces to make a push block. The following steps describe one way you can make a push block.

### Making the base:

- Start with a piece of 3/8 inch plywood at least 5-1/8 inches wide or wider and 14-3/4 inches long or longer
- Crosscut a 2-1/2 inch wide strip off the narrow end of the plywood. Put the larger piece aside for later.
- Cross cut a 3/8 inch wide piece off the end of the 2-1/2 inch wide strip. Put the 3/8 inch wide piece aside for later.
- Go back to the piece that is at least 5 1/8" wide or wider and 12 inches long or longer. Cut it to the size and shape shown.

### Putting it together

- Glue the 2-1/2 inch strip to the base, as shown:

**IMPORTANT:** The small piece of wood 3/8 inch x 3/8 inch x 2-1/2 inch should be glued to the plywood. Do not use nails. This is to prevent dulling of the sawblade in the event you cut in to the push block.

### Making the handle:

- Cut a piece of 3/4 inch thick plywood to shape and size shown:

**NOTE:** The mitered corners can be any size that looks like the drawing.

Slightly Less Than Thickness of Workpiece  
Up to 3/8"

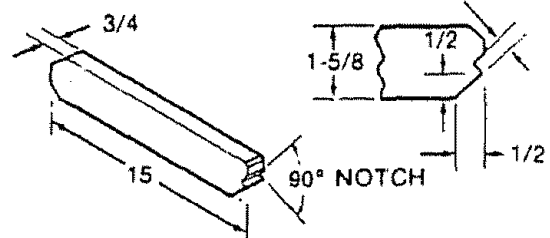

NOTE: All dimensions in inches

## PUSH STICK

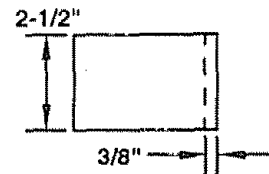
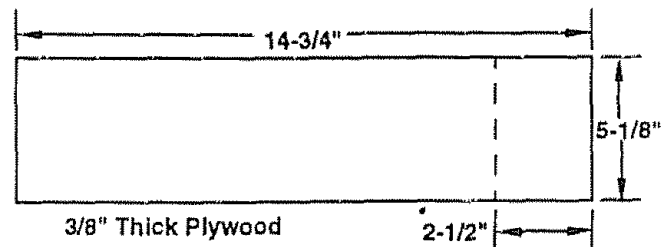

These Edges  
Must Be Parallel

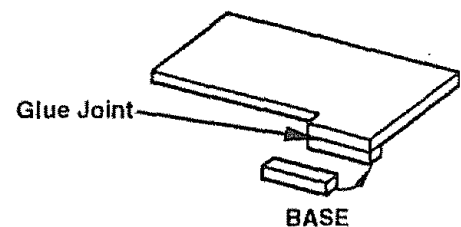
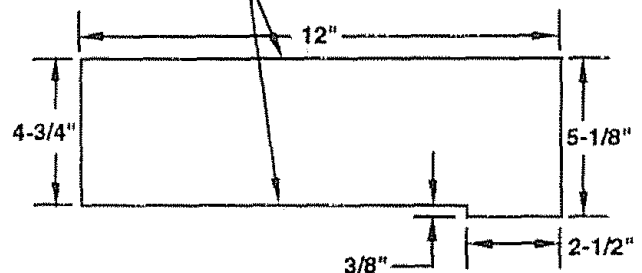

## BASE

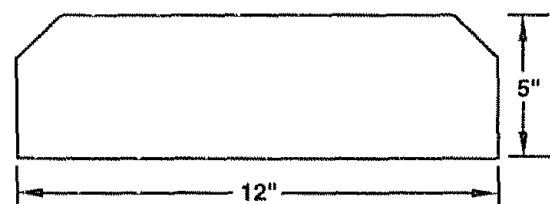

## 3/4" Thick Plywood HANDLE

## Work Feed Devices (continued)

- Position the handle in the center of the plywood base. Fasten them together with glue and wood screws.

**IMPORTANT:** Make sure the screw heads do not stick out from the bottom of the base, they must be flush or recessed. The bottom must be flat and smooth enough to slide along the auxiliary fence you are now ready to make.

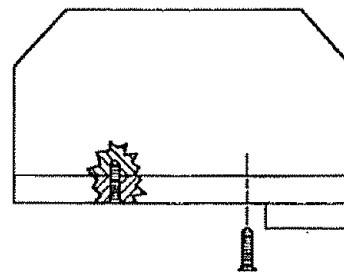
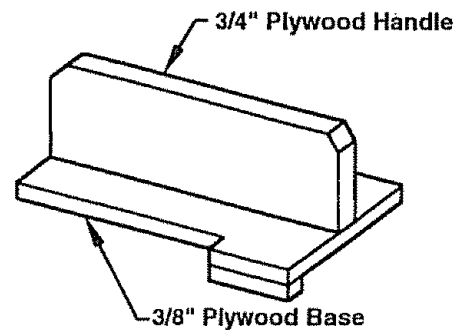

### Auxiliary Fence

#### Making the base:

- Start with a piece of 3/8 inch plywood at least 5-1/2 inches wide or wider and 16 inches long or longer.
- Cut the piece to shape and size shown:

#### Making the side:

- Start with a piece of 3/4 inch plywood at least 2-3/8 inches wide or wider and 16 inches long or longer.
- Cut the piece to shape and size shown:

#### Putting it together:

- Put the pieces together, as shown:

**IMPORTANT:** Make sure the screw heads do not stick out from the bottom of the base, they must be flush or recessed. The bottom must be flat and smooth enough to rest on the saw table without rocking.

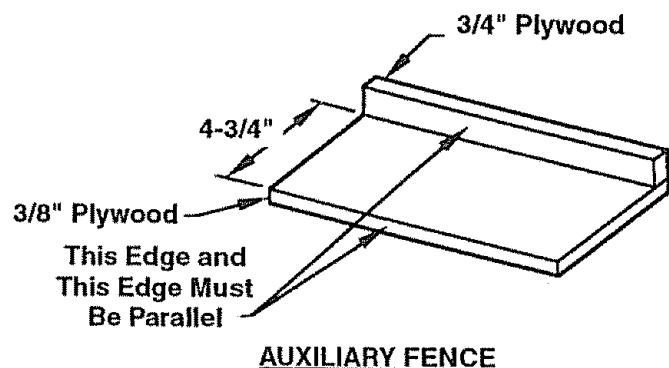
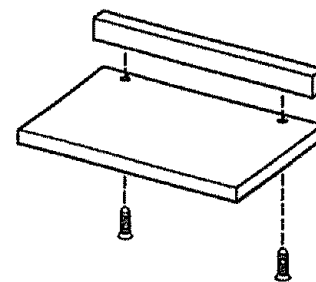
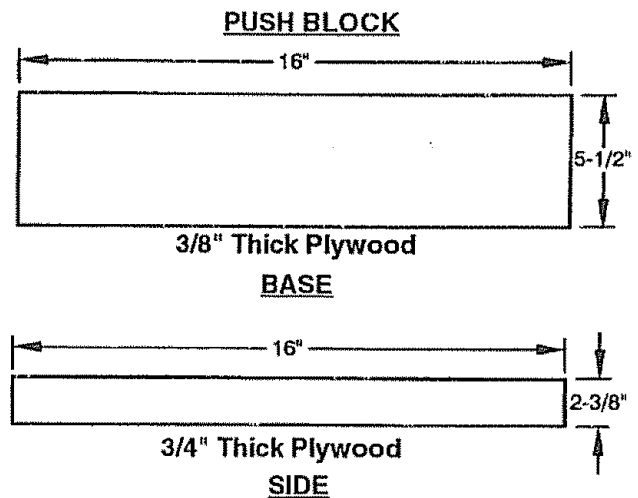

# Safety Instructions for Basic Saw Operations

## Before Each Use:

### Inspect your saw.

- To avoid injury from accidental starting, turn the switch off, unplug the saw, and remove the switch key before raising or removing the guard, changing the cutting tool, changing the setup, or adjusting anything.
- Check for alignment of moving parts, binding of moving parts, breakage of parts, saw stability, and any other conditions that may affect the way the saw works.
- If any part is missing, bent or broken in any way, or any electrical part does not work properly, turn the saw off and unplug the saw.
- Replace damaged or missing parts before using the saw again.
- Use the sawblade guard, spreader and anti-kickback pawls for any thru-sawing (whenever the blade comes through the top of the workpiece). Make sure the anti-kickback pawls work properly. Make sure the spreader is in line with sawblade (See page 10-11).
- Make sure all clamps and locks are tight and no parts have any excessive play.
- Remove adjusting keys and wrenches. Form a habit of checking for and removing keys and adjusting wrenches from table top before turning it on.
- Make sure all clamps and locks are tight and no parts have excessive play.

### To avoid injury from jams, slips or thrown pieces (kickbacks or throwbacks).

#### Inspect your blade.

- Choose the right blade or cutting accessory for the material and the type of cutting you plan to do.
- Never use grinding wheels, abrasive cutoff wheels, friction wheels (metal cutting blades) wire wheels or buffing wheels. They can fly apart explosively.
- Choose and inspect your cutting tool carefully:
  - To avoid cutting tool failure and thrown shrapnel (broken pieces of blade), use only 10 inch or smaller blades or other cutting tools marked for speeds of 5000 rpm or higher.
  - Always use unbroken, balanced blades designed to fit this saw's 5/8 inch arbor.
  - When thru-sawing (making cuts where the blade comes through the workpiece top), always use a 10 inch diameter blade. This keeps the spreader in closest to the blade.
  - Do not over tighten arbor nut. Use arbor wrenches to "snug" it securely.
  - Use only sharp blades with properly set teeth. Consult a professional blade sharpener when in doubt.
  - Keep blades clean of gum and resin.
- Never use the saw without the proper blade insert.

#### Inspect your work area.

- Keep work area clean.
- Cluttered areas and benches invite accidents. Floor must not be slippery from wax or sawdust.
- To avoid burns or other fire damage, never use the saw near flammable liquids, vapors or gases.
- To avoid injury, don't do layout, assembly, or setup work on the table while blade is spinning. It could cut or throw anything hitting the blade.

#### Plan your work.

- Plan ahead to protect your eyes, hands, face, ears.
- Use The Right Tool. Don't force tool or attachment to do a job it was not designed for.

#### Dress for safety.

- Do not wear loose clothing, gloves, neckties or jewelry (rings, wrist watches). They can get caught and draw you into moving parts.
- Wear nonslip footwear.
- Tie back long hair.
- Roll long sleeves above the elbow.
- Noise levels vary widely. To avoid possible hearing damage, wear ear plugs or muffs when using table saw for hours at a time.
- Any power saw can throw foreign objects into the eyes. This can result in permanent eye damage. Wear safety goggles (not glasses) that comply with ANSI Z87.1 (shown on package). Everyday eyeglasses have only impact resistant lenses. They are not safety glasses. Safety goggles are available at Sears retail stores. Glasses or goggles not in compliance with ANSI Z87.1 could seriously hurt you when they break.



- For dusty operations, wear a dust mask along with safety goggles.

#### Inspect your workpiece.

- Make sure there are no nails or foreign objects in the part of the workpiece to be cut.
- When cutting irregularly shaped workpieces, plan your work so it will not slip and pinch the blade:
- A piece of molding for example, must lie flat or be held by a fixture or jig that will not let it twist, rock or slip while being cut. Use jigs or fixtures where needed to prevent workpiece shifting.
- Use a different, better suited type of tool for work that can't be made stable.

# Safety Instructions for Basic Saw Operations (continued) —

## Plan your cut.

- To avoid kickbacks and throwbacks - when a part or all of the workpiece binds on the blade and is thrown violently back toward the front of the saw:
  - Never cut **freehand**. Always use either a rip fence, miter gauge or fixture to position and guide the work, so it won't twist or bind on the blade and kickback.
  - Make sure there's no debris between the workpiece and its supports.
- Use extra caution with large, very small or awkward workpieces:
- Use extra supports (tables, saw horses, blocks, etc.) for any workpieces large enough to tip when not held down to the table top. Never use another person as a substitute for a table extension, or as additional support for a workpiece that is longer or wider than the basic saw table, or to help feed, support or pull the workpiece.
- Never confine the piece being cut off, that is, the piece not against the fence, miter gauge or fixture. Never hold it, clamp it, touch it, or use length stops against it. It must be free to move. If confined, it could get wedged against the blade and cause a kickback or throwback.
- Never cut more than one workpiece at a time.
- Never turn your table saw "ON" before clearing everything except the workpiece and related support devices off the table.

## Plan the way you will push the workpiece through.

- **Never pull the workpiece through.** Start and finish the cut from the front of the table saw.
- **Never put your fingers or hands in the path** of the sawblade or other cutting tool.
- **Never reach in back** of the cutting tool with either hand to hold down, support the workpiece, remove wood scraps, or for any other reason.
- Avoid hand positions where a sudden slip could cause fingers or hand to move into a sawblade or other cutting tool.
- **Don't Overreach.** Always keep good footing and balance.
- Push the workpiece against the rotation of the blade. Never feed material into the cutting tool from the rear of the saw.
- Always push the workpiece all the way past the sawblade.
- As much as possible, keep your face and body to one side of the sawblade, out of line with a possible kickback or throwback.
- Set the cutting tool as low as possible for the cut you're planning.

## Avoid accidental starting.

- Make sure switch is "OFF" before plugging saw into a power outlet.

## Whenever Sawblade Is Spinning:

**WARNING: Don't allow familiarity (gained from frequent use of your table saw) cause a careless mistake. Always remember that a careless fraction of a second is enough to cause a severe injury.**

- Before actually cutting with the saw, watch it while it runs for a short while. If it makes an unfamiliar noise or vibrates a lot, stop immediately. Turn the saw off. Unplug the saw. Do not restart until finding and correcting the problem.
- Make sure the top of the arbor or cutting tool turns toward the front of the saw.

## Keep children away.

- Keep all visitors a safe distance from the table saw.
- Make sure bystanders are clear of the table saw and workpiece.

## Don't force tool.

- Let the blade reach full speed before cutting.
- It will do the job better and safer at its designed rate.
- Feed the workpiece into the saw only fast enough to let the blade cut without bogging down or binding.

## Before freeing jammed material.

- Turn switch "OFF".
- Unplug the saw.
- Wait for all moving parts to stop.
- Check blade, spreader and fence for proper alignment before starting again.

## To avoid throwback of cut off pieces.

- Use the guard assembly.

## To remove loose pieces beneath or trapped inside the guard.

- Turn saw "OFF".
- Remove switch key.
- Wait for blade to stop before lifting the guard.

## Before leaving the saw.

- Turn the saw off.
- Wait for blade to stop spinning.
- Unplug the saw.
- Make workshop child-proof. Lock the shop. Disconnect master switches. Remove the yellow switch key. Store it away from children and others not qualified to use the tool.



# Basic Saw Operations

## Using the Miter Gauge

The miter gauge is used when crosscutting, miter cutting, bevel cutting, compound miter cutting, dadoing and when rabbeting across the end of a narrow workpiece.

**WARNING: For your own safety, always observe the following safety precautions in addition to the safety instructions of pages 2, 3, 4, 5, 23 & 24.**

### Additional Safety Instructions for Crosscutting

#### Before Starting:

- Never use the rip fence when crosscutting.
- An auxiliary wood facing attached to the miter gauge can help prevent workpiece twisting and throwbacks. Attach it to the holes provided. Make the facing long enough and big enough to support your work. Make sure, however, it will not interfere with the sawblade guard.
- Use jigs or fixtures to help hold any piece too small to extend across the full length of the miter gauge face during the cut. This lets you properly hold the miter gauge and workpiece and helps keep your hands away from the blade.
- Use extra supports such as plywood clamped to a sawhorse for workpieces that are long and heavy enough to tip or that tend to raise the miter gauge from the groove in the table, never use another person as a substitute for a support or to help feed or pull the workpiece.

#### While cutting:

- To avoid blade contact, always hold the miter gauge as shown in this section.

### Crosscutting

A crosscut is known as cutting or shaping operation made across the width of a workpiece.

The graduations on the miter gauge provide accuracy for average woodworking. In some cases where extreme accuracy is required, when making angle cuts, for example, make a trial cut and then recheck it with an accurate square, or protractor.

If necessary, the miter gauge head can be swiveled slightly to compensate for any inaccuracy.

**NOTE:** The space between the miter gauge bar and the groove in the table is held to a minimum during manufacturing.

For maximum accuracy when using the miter gauge, always favor one side of the groove in the table. In other words, don't move the miter gauge from side to side while cutting but keep one side of the bar riding against one side of the groove.

**NOTE:** Glue a piece of sandpaper to the face of the miter gauge head. This will help prevent the workpiece from "creeping" while it is being cut.

**WARNING: To avoid blade contact or kickback, hold miter gauge properly.**

When using the miter gauge in the left hand groove, hold the workpiece firmly against gauge head with your left hand, and grip the lock knob with your right hand.

When using the miter gauge in the right hand groove, hold the workpiece with your right hand and the lock knob with your left hand.

Miter gauge head is locked in position for crosscutting or mitering by tightening the lock knob. Always lock it securely when in use.

Holes are provided in the miter gauge for attaching an auxiliary facing to make it easier to cut long pieces. Make sure facing does not interfere with the proper operation of the sawblade guard.

Select a suitable piece of smooth straight wood, drill two holes through it and attach it with screws.

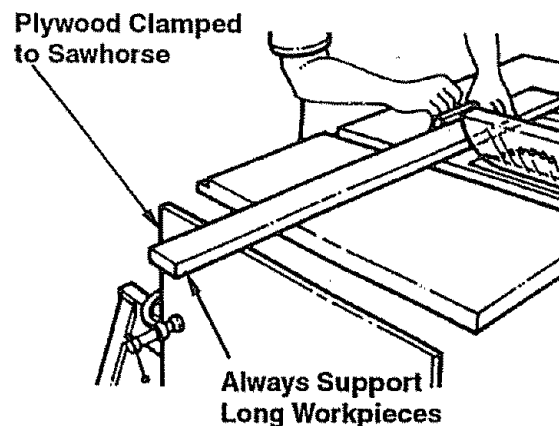

# Basic Saw Operations (continued)

## Repetitive Crosscutting

Repetitive cutting is known as cutting a quantity of pieces the same length without having to mark each piece.

- When making repetitive cuts from a long workpiece, make sure it is supported.

**WARNING: Never use the rip fence as a length stop because the cutoff piece could bind between the fence and the blade causing a kickback.**

1. When making repetitive cuts, clamp a block of wood 3' long to the table at desired length to act as a length stop.

**WARNING: To avoid kickback from twisting the workpiece, when clamping the block, make sure that the end of the block is well in front of the saw blade. Be sure it is clamped securely.**

2. Slide the workpiece along the miter gauge until it touches the block...hold the workpiece securely against the miter gauge.
3. Make the cut...turn the saw off...remove the piece after the blade has stopped and before cutting the next piece.

## Miter Crosscutting

Miter cutting is an angle cutting operation made across the width of the workpiece. Follow the same procedure as you would for crosscutting.

- Adjust the miter gauge to the desired angle, and lock it.
- The miter gauge may be used in either of the grooves in the table. Make sure it is locked.
- When using the miter gauge in the left hand groove, hold the workpiece firmly against the miter gauge head with your left hand, and grip the lock knob with your right hand.
- When using the miter gauge in the right hand groove, hold the workpiece with your right hand and the lock knob with your left hand.

## Bevel Crosscutting

Bevel crosscutting is the same as crosscutting except that the wood is also cut at an angle...other than 90° with the bottom flat side of the wood.

- Adjust the blade to the desired angle.
- Always use the miter gauge in the groove to the right of the blade. It cannot be used in the groove to the left because the blade guard will interfere. Hold the workpiece with your right hand and the lock knob with your left hand.

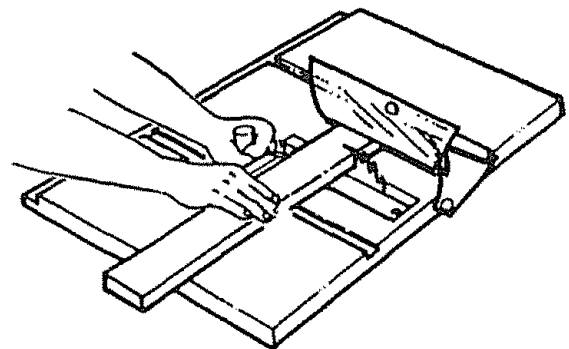
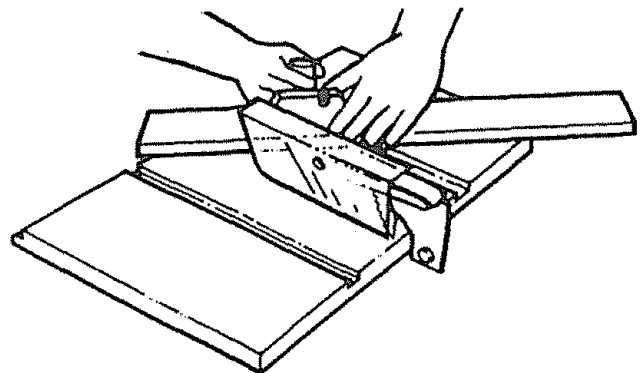
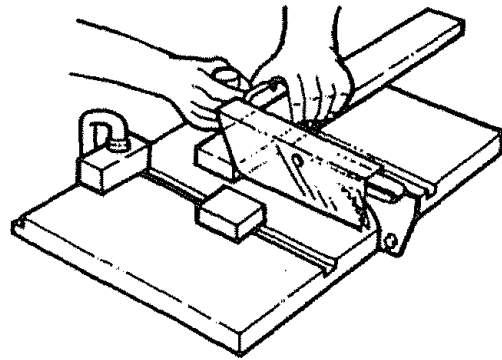

## Compound Miter Crosscutting

Compound miter cutting is a combination of miter cutting and bevel crosscutting. The cut is made at an angle other than 90° to both the edge and the bottom flat side of the wood.

- Adjust the miter gauge and the blade to the desired angle...Make sure miter gauge is locked.
- Always use the miter gauge in the groove to the right of the blade. It cannot be used in the groove to the left because the blade guard will interfere. Hold the workpiece with your right hand and the lock knob with your left hand.

## Using the Rip Fence

### Additional Safety Instructions for Rip Cuts

#### Before starting:

- Never use the miter gauge when ripping
- Use a push stick whenever the fence is 2 or more inches from the blade.
- When thru-sawing, use an auxiliary fence and push block whenever the fence must be between 1/2 and 2 inches from the blade.
- Never thru-saw rip cuts narrower than 1/2 inch. (See "Basic Saw Operations-Ripping and Bevel Ripping" section).
- Never rip anything shorter than 10" long.
- When using a push stick or push block, the trailing end of the workpiece must be square. A push stick or push block against an uneven end could slip off or push the workpiece away from the fence.
- A featherboard can help guide the workpiece. (see "Basic Saw Operation-Using Featherboards for Thru-Sawing." section)
- Always use featherboards for any non thru-sawing rip type cuts. (see "Basic Saw Operations-Using Featherboards for Non Thru-sawing" section)
- To avoid kickbacks and slips into the blade, make sure the rip fence is parallel to the sawblade.
- Before thru-sawing, check the anti-kickback pawls. the pawls must stop a kickback once it has started. Replace or sharpen anti-kickback pawls when points become dull.
- Plastic and composition (like hardboard) materials may be cut on your saw. However, since these are usually quite hard and slippery, the anti-kickback pawls may not stop a kickback. Therefore, be especially careful in your set-up and cutting procedures.

#### While Thru-sawing:

- To avoid kickbacks and slips into the blade, always push forward on the section of the workpiece between the sawblade and the rip fence. Never push forward on the piece being cut off.

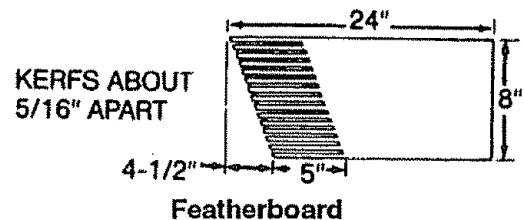

## Basic Saw Operations (continued)

### Ripping

Ripping is known as a cutting operation along the length of the workpiece.

Position the fence to the desired width of rip and lock in place.

Before starting to rip, be sure:

1. Rip fence is parallel to sawblade.
2. Spreader is properly aligned with sawblade.
3. Anti-kickback pawls are functioning properly.

When ripping long boards or large panels, always use a work support. A simple support can be made by clamping a piece of plywood to a sawhorse.

**WARNING: To avoid kickback, push forward only on the part of the workpiece that will pass between the blade and the fence.**

Keep your hands out of the blade path.

Feed the workpiece by pushing forward only on the part of the workpiece that will pass between the blade and the fence.

Stop the thumb of your outside hand at the front edge of the table. Finish the cut with the appropriate push stick or push block.

**Once the trailing end is on the table:**

When "width of rip" is 2" or wider, use the push stick to finish the work all the way past the blade.

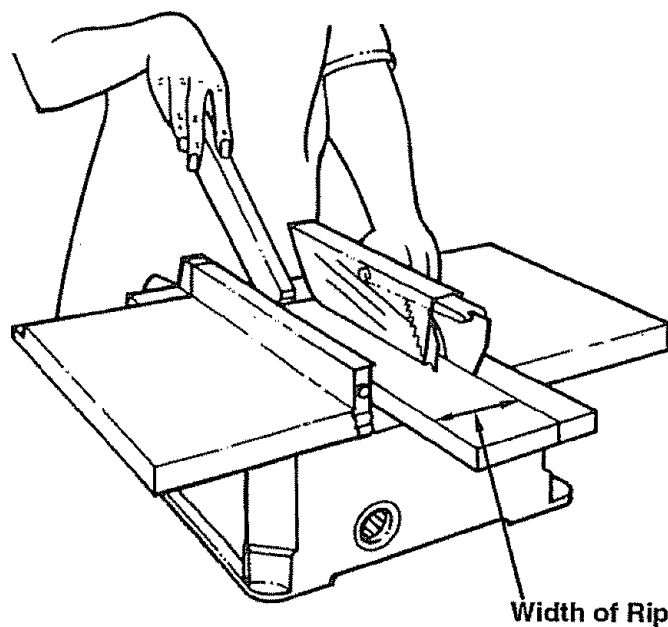
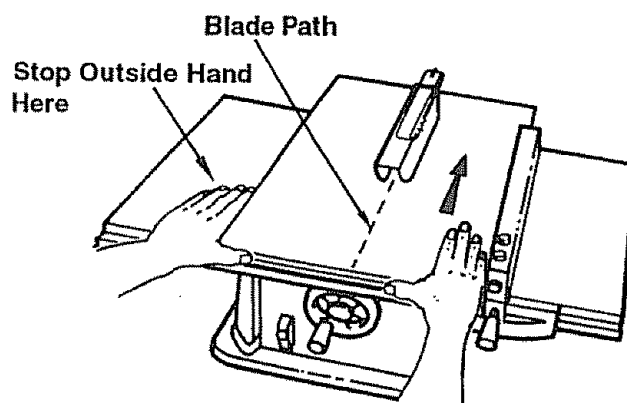
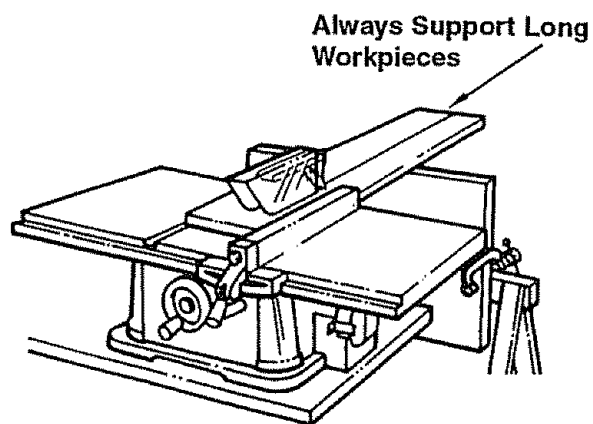

When "width of rip" is narrower than 2", the push stick cannot be used because the guard will interfere. Use the auxiliary fence and push block for this ripping operation. Attach auxiliary fence to rip fence with two "C" clamps.

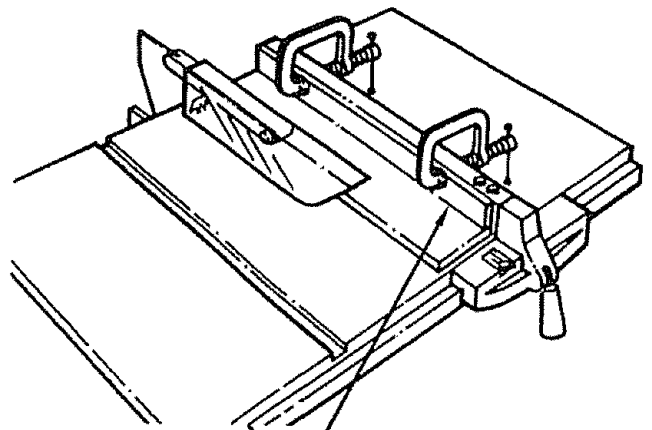

Auxiliary Work Support/Fence

Feed the workpiece by hand along the auxiliary fence until the end is approximately 1" past the front edge of the table. Continue to feed using the push block.

Hold the workpiece in position and install the push block by sliding it on top of the auxiliary fence/work support. This may raise the guard.

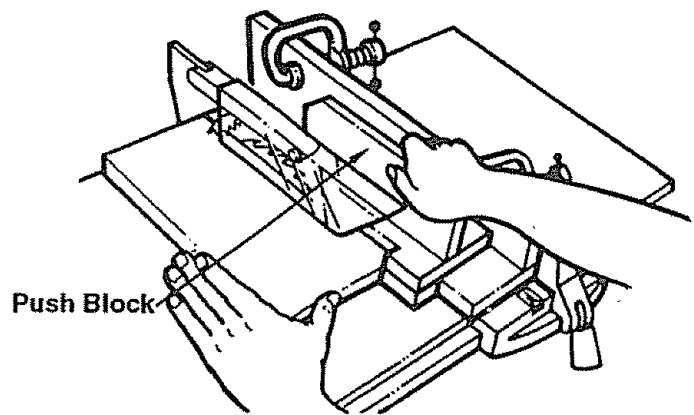

Push Block

**WARNING:** To avoid injury from blade contact never perform thru-saw cuts narrower than 1/2" wide.

Narrow strips thicker than the auxiliary fence/work support may enter the guard and strike the baffle. Carefully raise guard only enough to clear the workpiece. Use push block to complete cut.

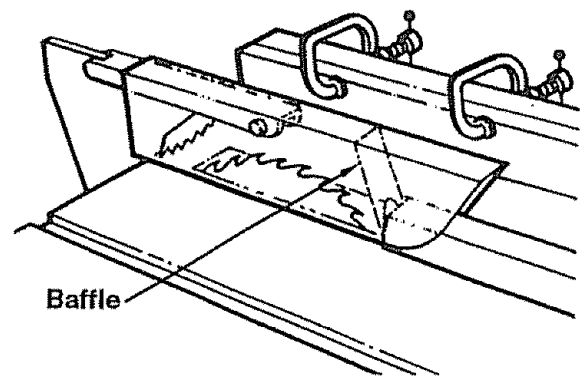

Baffle

### Bevel Ripping

When bevel ripping material 6" or narrower, use fence on the right side of the blade only. This will provide more space between the fence and the sawblade for use of a push stick. If the fence is mounted to the left, the sawblade guard may interfere with proper use of a push stick.

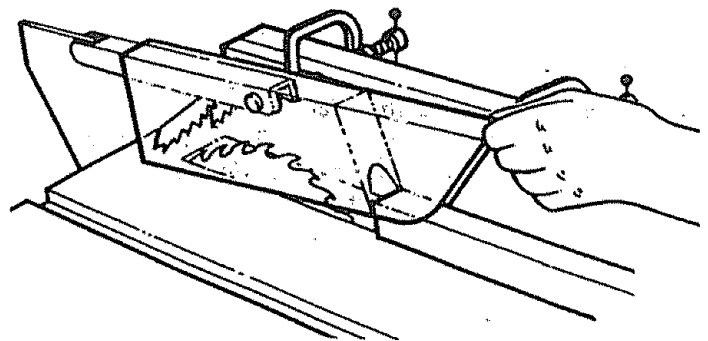

## Basic Saw Operations (continued)

### Using Featherboards for Thru-Sawing

Featherboards are not employed for thru-sawing operations when using the miter gauge.

Featherboards are used to keep the work in contact with the fence and table as shown, and to help stop kickbacks. Add a 7-1/2" high flat facing board to the full length of the fence.

Mount featherboards to fence and table as shown.

**WARNING: Make sure the featherboard against the edge presses only on the uncut portion (in front of the blade). It might otherwise pinch the blade in the kerf and cause a kickback.**

Before starting the operation (turn switch "OFF" and lower blade or cutter below table surface):

- Install featherboards so they exert pressure on the workpiece; be positive they are securely attached.
- Make sure by trial that the featherboards will stop a kickback if one should occur before performing this operation.

Before starting your cut:

- Slide the workpiece in between the featherboards the same way you'll feed it in for the cut.
- Pull back on the workpiece. The piece should be harder to pull back than it was to push forward.
- Adjust your featherboards and repeat the trial, as needed.
- Follow the applicable ripping instructions to make the cut.

### Resawing

Resawing is a thru-sawing cut made by ripping a piece of wood through its thickness.

**WARNING: Do not attempt to resaw bowed or warped material. It can't be properly supported. It could kickback or bind.**

**NOTE:** To resaw a piece of wood wider than 3", it will be necessary to remove the blade guard and use the auxiliary fence/work support. (See "Workfeed Devices" on page 21-22).

Clamp the auxiliary fence/work support to the table so that the workpiece will slide easily without binding between the two fences and it will not tilt or move sideways.

Do not clamp directly to the bottom edge of the table because the "swivel" of the clamp will not grip properly. Place a small block of wood between the bottom edge of the table and the "C" clamp.

**WARNING: For your own safety**

1. Do not "Backup" (reverse feeding) while resawing because this could cause a kickback.
2. Make first pass to a depth slightly more than one half the width of the board; keep same face of board against fence for second pass.

**WARNING: For your own safety, install blade guard immediately upon completion of the resawing operation.**

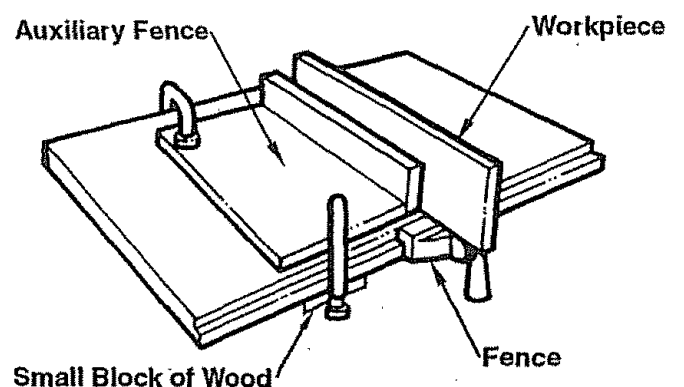
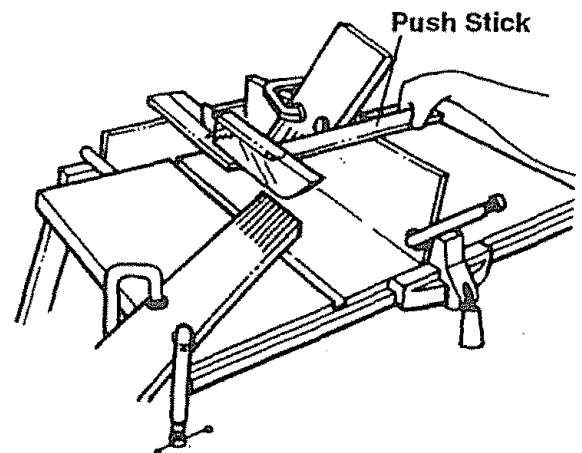
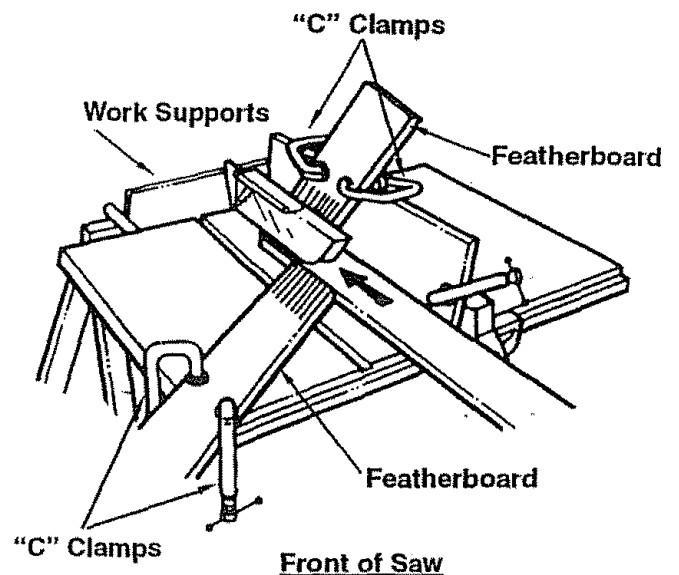

## Using Featherboards for Non Thru-Sawing

Featherboards are not employed during non thru-sawing operations when using the miter gauge.

Use featherboards for all other non thru-sawing operations (when sawblade guard must be removed). Featherboards are used to keep the work in contact with the fence and table as shown and to stop kickbacks.

Add a 7-1/2" high flat facing board to the full length of the fence.

Mount featherboards to fence and table as shown, so that leading edges of featherboards will support workpiece until cut is complete, and the workpiece has been pushed completely past the cutter (sawblade, dado-head, etc.) with a push stick, as in ripping.

Before starting the operation (turn switch "OFF" and lower blade or cutter below table surface):

- Install featherboards so they exert pressure on the workpiece; be positive they are secure.
- Make sure by trial the featherboards will stop a kick-back if one should occur before performing this operation.

Before starting your cut:

- Slide the workpiece in between the featherboards the same way you'll feed it in for the cut.
- Pull back on the workpiece. The piece should be harder to pull back than it was to push forward.
- Adjust your featherboards and repeat the trial, as needed.
- Follow the applicable ripping instructions to make the cut.

**WARNING: For your own safety, always replace the blade, blade guard, spreader and blade insert as soon as the non thru-sawing operation is complete.**

## Dadoing

Instructions for operating the dado head are contained in booklet furnished with the dado head.

The arbor on the saw is only long enough so that the widest cut that can be made is 9/16" wide.

It is not necessary to install the outside loose collar before screwing on the arbor nut. Make sure the arbor nut is tight and at least one thread on the arbor sticks out past the nut.

**Always use dado insert listed under recommended accessories.**

When using the dado head, it will be necessary to remove the blade guard and spreader. Use caution. Use miter gauge, fence, featherboards or push sticks as required.

**WARNING: For your own safety, always replace the blade, blade guard, spreader and blade insert when you are finished dadoing.**

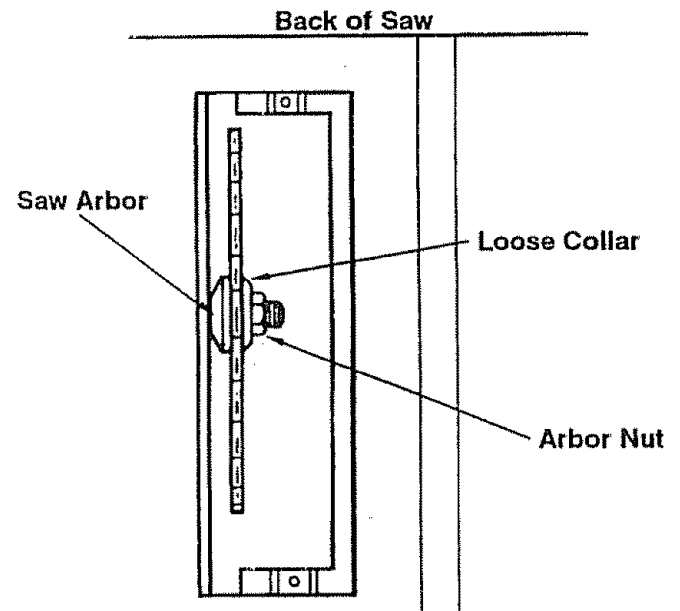
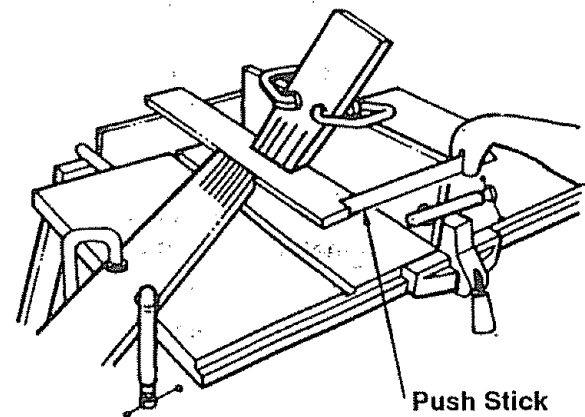
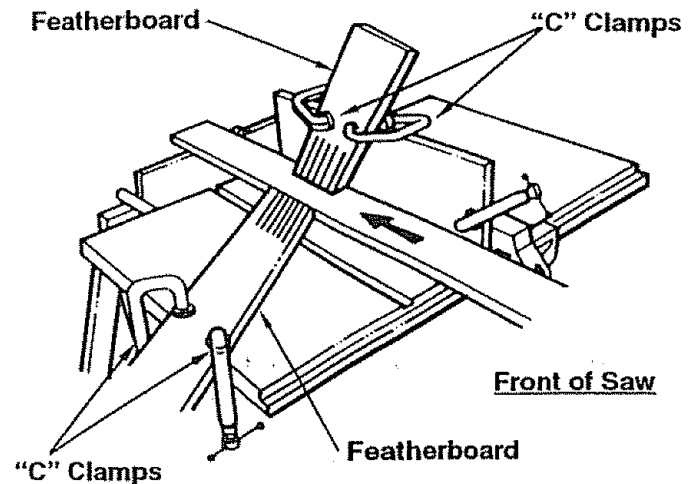

**Remove Sawblade and Install Dado Head and Dado Insert**

## Basic Saw Operations (continued)

### Rabbeting

Rabbeting is known as cutting out a section of the corner of a piece of material, across an end or along an edge.

To make a rabbet requires cuts which do not go all the way through the material. Therefore, the blade guard must be removed.

1. Remove blade guard.
2. For rabbeting along an edge (long way of workpiece) as shown, add facing to rip fence approximately as high as the workpiece is wide. Adjust rip fence and blade to required dimensions; then make first cut with board flat on table as you would with any rip (type) cut; make second cut with workpiece on edge. Follow all precautions, safety instructions, and operational instructions as for ripping, or rip type operations, including featherboards and push stick, etc.
3. For rabbeting across an end, for workpiece 10-1/2" and narrower, make the rabbet cut with the board flat on the table. Using the miter gauge fitted with a facing, follow the same procedures and instructions for cross cutting making successive cuts across the width of the workpiece to obtain the desired width of cut. Do not use the rip fence for rabbeting across the end.

**WARNING: For your own safety, install blade guard immediately upon completion of rabbeting operation.**

Some rabbet cuts can also be made in one pass of the workpiece over the cutter using a dado head.

### Ploughing and Molding

Ploughing is grooving with the grain the long way of the workpiece, using the fence. Use featherboards and push sticks as required.

Molding is shaping the workpiece with the grain the long way of the workpiece, using the fence. Use featherboards and push sticks as required.

**WARNING: For your own safety, always replace the blade, blade guard, spreader and blade insert when you are finished.**

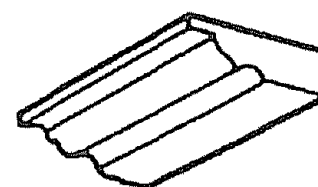
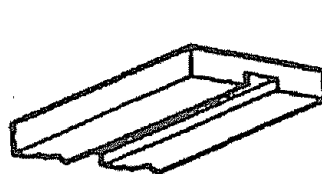
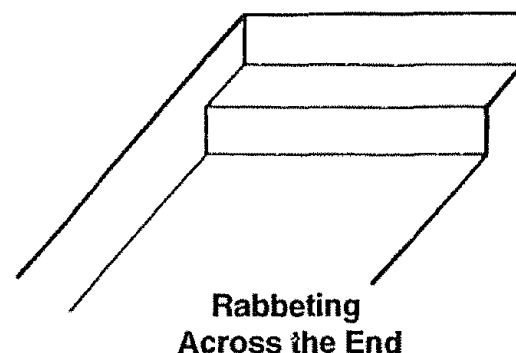
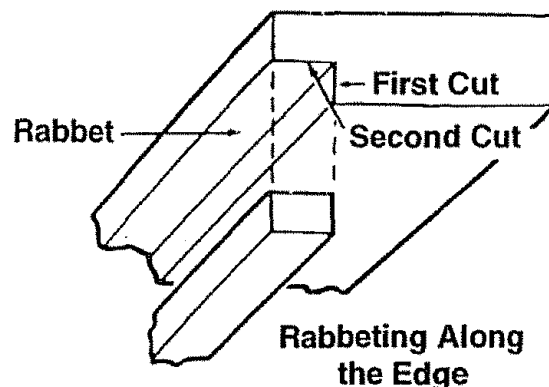



## Installation and Operation of Molding Head

To get full arbor nut engagement with the arbor threads, this saw requires a special molding head mounting arrangement. Always arrange and mount the molding head as shown. Instructions for assembling and operating the molding head are contained in a booklet furnished with the molding head.

Follow molding head installation instructions for table saws, except use the loose blade collar supplied with the saw instead of the spacer washer supplied with the molding head. Do **NOT** use the spacer washer provided with the molding head. Always position the loose blade collar as shown.

**Always use the molding insert listed under recommended accessories.**

When using the molding head it will be necessary to remove the blade guard and spreader. Use caution. Use miter gauge, fence, featherboards, or push sticks, etc., as required.

**WARNING: For your own safety, always replace the blade, blade guard, spreader and blade insert when you are finished molding.**

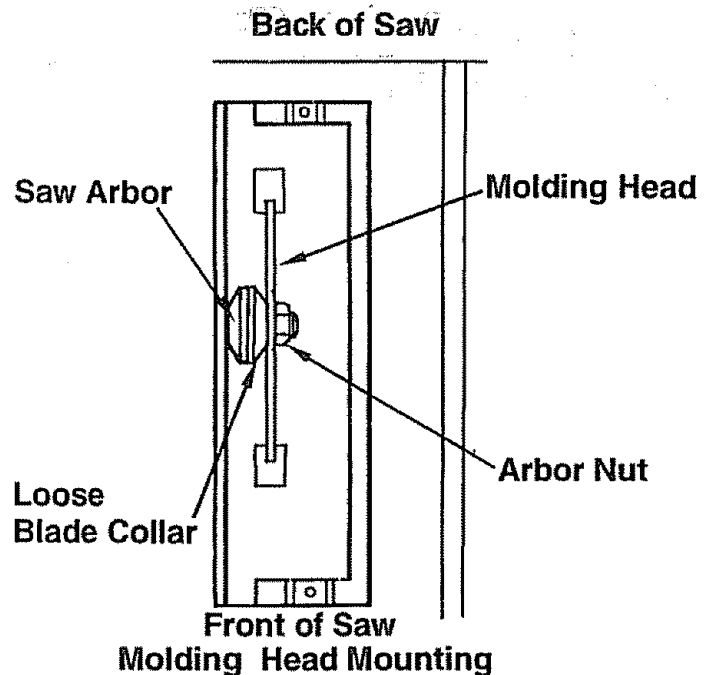

## Maintaining Your Table Saw

### Maintenance

**WARNING: For your own safety, turn switch "OFF" and remove plug from power source outlet before maintaining or lubricating your saw.**

- Do not allow sawdust to accumulate inside the saw. Frequently blow out any dust that may accumulate inside the saw cabinet and the motor.
- Clean your cutting tools with a gum and pitch remover.
- The cord and the tool should be wiped with a dry clean cloth to prevent deterioration from oil and grease.
- A coat of automobile-type wax applied to the table will help to keep the surface clean and allow workpieces to slide more freely.
- If the power cord is worn, cut, or damaged in any way, have it replaced immediately.

**IMPORTANT:** Certain cleaning agents and solvents can damage plastic parts. Some of these are: gasoline, carbon tetrachloride, chlorinated cleaning solvents, ammonia and household detergents which contain ammonia. Avoiding use of these and other types of cleaning agents will minimize the possibility of damage. Use cleaners suitable for prescription glasses or liquid dishwashing detergent and water.

### Anti-Kickback Pawls

Make sure the teeth of the anti-kickback pawls are always sharp. To sharpen:

1. Remove blade guard.
2. Rotate pawl toward rear of spreader so that teeth are above top of spreader.
3. Hold spreader with left hand and place pawl over corner of workbench as shown.
4. Using a small round file, (smooth cut) sharpen the teeth.
5. Reinstall blade guard.

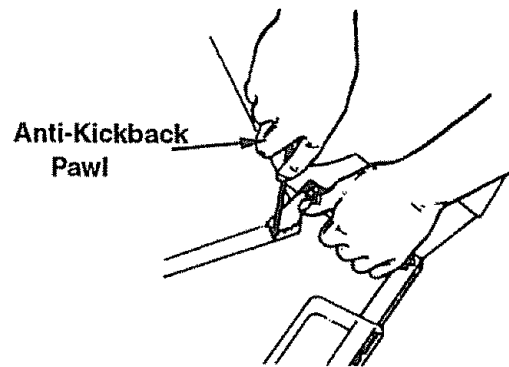

**WARNING: All repairs, electrical or mechanical, should be attempted only by a trained repairman. Contact the nearest Sears store for service. Use only identical replacement parts. Any other parts may create a hazard.**

## Maintaining Your Table Saw (continued)

### Lubrication

The saw motor bearings and gear case have been packed at the factory with proper lubricant and require no additional lubrication. The following parts should be oiled occasionally with SAE no. 20 or no. 30 engine oil.

1. Elevation screw threads and pivot nut.
2. Elevation bracket pivot points.
3. Bearing points in blade guard, miter gauge and rip fence assemblies (as shown by\*).

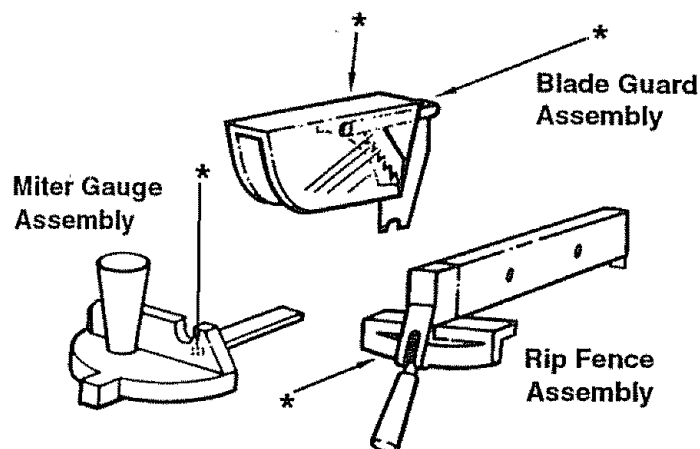

## Sears Recommends the Following Accessories

Item	Cat. No.
Saw Blades.....	See Catalog
Dado/Molding Head Insert.....	9-29971
5-5/8" Molding Head.....	See Catalog
6" Dado Set.....	See Catalog

**WARNING: Do not use adjustable (wobble) type dados or carbide tipped dado blades on this saw. Maximum dado width is 9/16 inch.**

Steel Leg Set.....	9-22235
Caster Set.....	9-22222, 9-22221

Sears may recommend other accessories not listed in manual.

See your nearest Sears Store or Power and Hand Tool Catalog for other accessories.

Do not use any accessory unless you have received and read complete instructions for its use.

**WARNING: Use only accessories recommended for this saw. Using other accessories may be dangerous.**

# Troubleshooting

**WARNING: To avoid injury from accidental start, turn switch "OFF" and always remove plug from the power source before trouble shooting.**

TROUBLE	PROBABLE CAUSE	REMEDY
Excessive vibration	1. Blade out of balance.	1. Discard blade and use a different blade.
	1. Miter gauge not adjusted properly.	1. See "Adjustments" section "Miter gauge"
Cut binds, burns or stalls motor when ripping.	1. Dull blade or improper tooth set. 2. Warped board 3. Rip fence not parallel to blade. 4. Spreader out of alignment	1. Sharpen or replace blade. 2. Make sure concave side is facing "down", feed slowly. 3. See "Assembly" section, "Aligning Rip Fence." 4. See "Assembly" section, "Installing Blade Guard."
Bevel cut not true 90° or 45°	1. Stop screw not properly adjusted.	1. See "Adjustments" section, "Blade tilt, or squareness of blade to table."
Elevating handwheel hard to turn	1. Sawdust on threads of elevating screw. 2. Over tightening handwheel when raising blade.	1. See "Maintenance and Lubrication" section. 2. Don't over tighten handwheel. Check to see if Key No. 33 on page 38 is binding.
Excessive blade wobble (causes oversize kerf and unsmooth cut.)	1. Blade has excessive wobble. 2. Blade loose.	1. Replace blade. 2. See "Installing Sawblade" section.
Excessive noise	1. Motor	1. Have motor checked by Sears Service Center.
Motor starts slowly or fails to develop full power. <b>NOTE:</b> A low voltage condition will cause the power output of the motor to decrease rapidly. For example, a reduction of 10% in voltage causes a reduction of 19% in maximum power output of which the motor is capable.	1. Circuit overloaded with lights, appliances and other motors. 2. Undersize wires or circuit too long. 3. General overloading of power company facility. (In some sections of the country, demand for electrical power may exceed the capacity of existing generating and distribution systems.) 4. Incorrect fuses or circuit breakers in power line. 5. Bad/worn brushes	1. Do not use other appliances or motors on the same circuits when using the saw. 2. Increase wire sizes, or reduce length of wiring. See "Motor Specifications and Electrical Requirements" section. 3. Request a voltage check from the power company. 4. Install correct fuses or circuit breakers. 5. Have brushes replaced by Sears Service Center.
Motor overheats.	1. Motor overloaded. 2. Improper cooling, (motor air circulation restricted due to sawdust accumulating inside of saw).	1. Do not cut so fast. Feed work slower into blade. 2. Clean out sawdust to provide normal air circulation through motor. See "Maintenance and Lubrication" section.
Motor stalls (resulting in blown fuses or tripped circuit breakers.)	1. Voltage too low to permit motor to reach operating speed. 2. Fuses or circuit breakers do not have sufficient capacity. 3. Feed rate too fast or dull blade.	1. Request voltage check from the power company. 2. Install proper size fuses or circuit breakers. 3. Allow motor to cool and reset saw breaker.
Frequent opening of fuses or circuit breakers	1. Motor overloaded 2. Fuses or circuit breakers do not have sufficient capacity. 3. Feed rate too fast or dull blade.	1. Don't cut so fast. Feed work slower into blade. 2. Install proper size fuses or circuit breakers. 3. Allow motor to cool and reset saw breaker.
Fence is hard to slide	1. Front fence rail surface is dry.	1. Apply a coat of paste wax to the top, front and rear edge of the front fence rail surfaces.

Parts List for Craftsman 10" Bench Top Table Saw  
Model No. 113.221740  
Figure 1

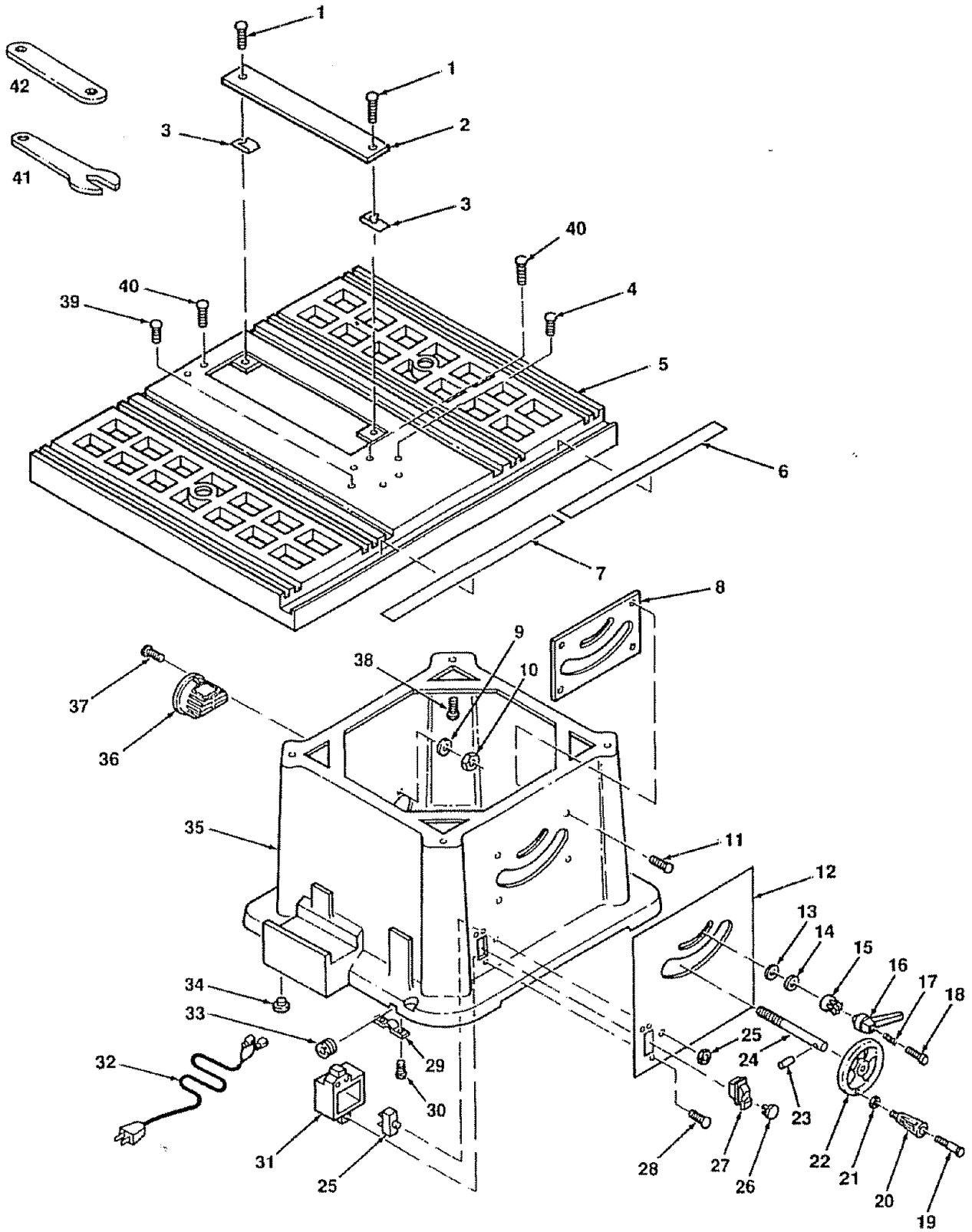

## Parts List for Craftsman 10" Bench Top Table Saw Model No. 113.221740

Always Order by Part Number - Not Key Number

Figure 1

Key No.	Part No.	Description
1	817357-1	Screw, Ty "E" M4 x 16-12
2	822497	Insert, Table
3	822498	Nut, Speed M4 x 16
4	822487-1	Screw, Cr-Special
5	823170	Table
6	823023	Scale R.H.
7	823022	Scale L.H.
8	823046	Clamp, Plate
9	STD852004	* Lockwasher, Ext. M4
10	56-100002	Nut, Hex M4 x .7
11	823047	Screw, Cr Flat Hd M3 x .5-7
12	823167	Label, Trim Panel
13	STD551025	* Washer, 17/64 x 5/8 x 1/32
14	60545	Washer, Nylon
15	823042	Nut, Locking
16	823041	Knob, Bevel Lock
17	823044	Spring, Compression
18	823043	Bolt, Special
19	823086	Screw Fillister Head
20	823085	Knob
21	STD541031	* Nut, Hex 5/16-18
22	823052	Handwheel, Elevation

Key No.	Part No.	Description
23	813249-132	Pin, Roll
24	823053	Rod, Screw
25	823050	<input type="checkbox"/> Reset Switch, w/nut
26	9-22255	† Key, Locking
27	822308	Switch, Locking
28	STD611007	* Screw, Ty "AB" #10 x 3/4
29	823010	Clamp, Cord
30	STD610807	* Screw, Pan Hd #8 x 3/4
31	823012	Box, Switch
32	823048	Cord w/plug
33	823094	Grommet
34	823049	Foot, Rubber
35	823172	Base
36	823024	Outlet, Dust
37	46-57680-3	* Screw, M4 x .7-16
38	822493	Screw, Hex Serr. Flat Hd
39	822487	Screw, Cr-Special
40	823001	Screw, Cr-Special
41	820816	Wrench, Shaft $\frac{1}{2}$ "
42	820815	Wrench, Arbor Nut
	SP5754	Owners Manual (not Illustrated)

\* Standard Hardware Item - May be purchased locally

† Stock Item - May be secure through the hardware department of most Sears retail stores.

**WARNING: Service of double-insulated parts. In a double-insulated tool, two systems of insulation are provided instead of grounding. No grounding means is provided on a double-insulated tool nor should a means for grounding be added. Servicing a double insulated tool requires extreme care and knowledge of the system, and should be done by a qualified service personnel. Replacement parts for a double-insulated tool must be identical to the parts they replace. Your double-insulated tool is marked with the words "DOUBLE-INSULATED" and the  (square within a square).**

# Repair Parts

## Parts List for Craftsman 10" Bench Top Table Saw Model No. 113.221740

Figure 2

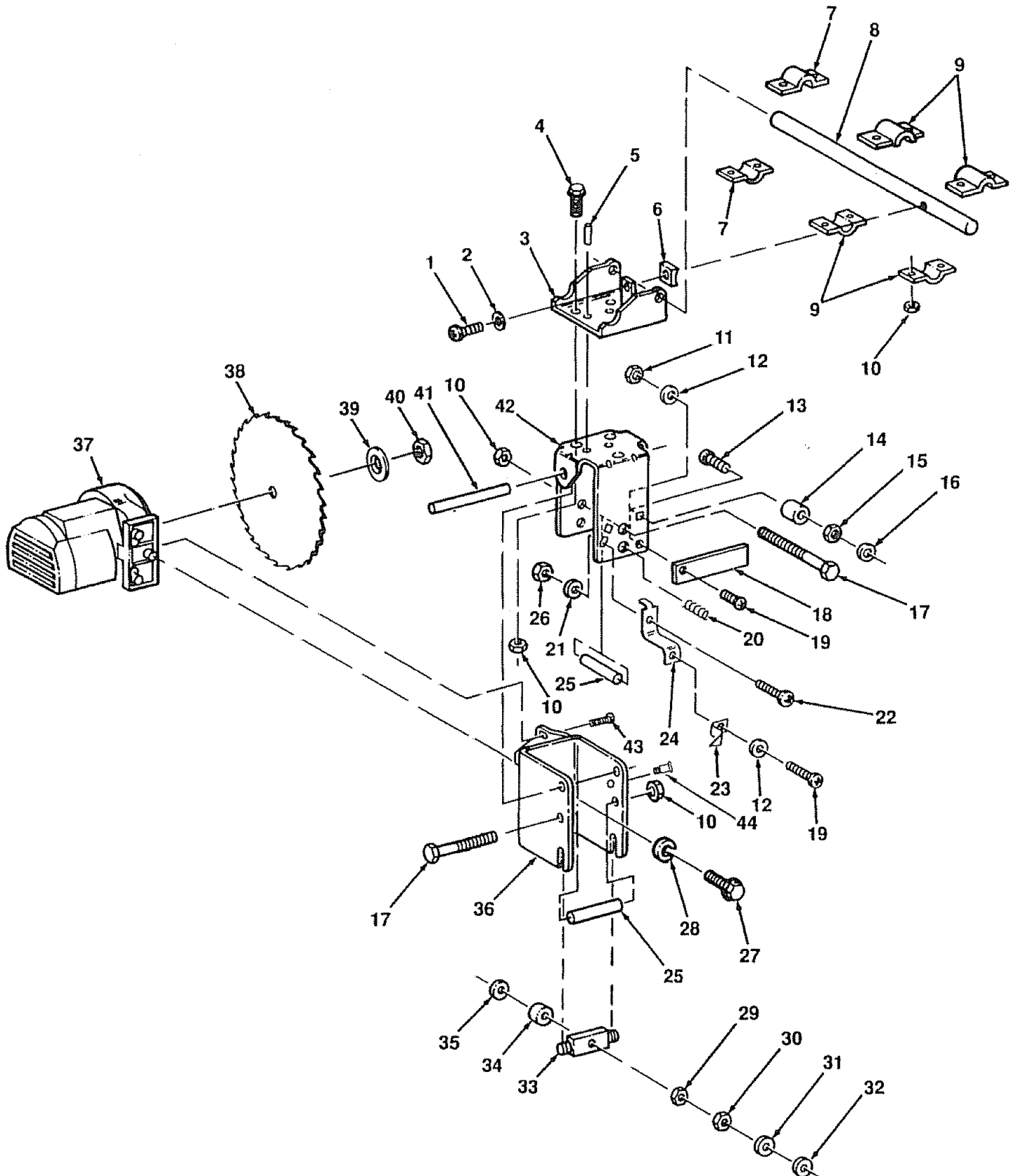

# Repair Parts

## Parts List for Craftsman 10" Bench Top Table Saw Model No. 113.221740

Always Order by Part Number - Not Key Number

Figure 2

Key No.	Part No.	Description
1	821151-3	Screw, Hex Hd. M5 x .8-20
2	STD852005	* Lockwasher, Ext. M5
3	823035	Bracket, Pivot Rod
4	823105	Screw, Serr Hd. 1/4-20 x 3/4
5	813249-104	Pin, Roll 4 x 16
6	823037	Spacer
7	823000	Clamp, Rod Pivot Rear
8	823034	Rod, Pivot
9	822499	Clamp, Rod Pivot
10	822488	Nut, Hex 1/4-20
11	STD541010	* Nut, Hex 10-24
12	STD551210	* Lockwasher, Ext. #10
13	822489-1	Bolt, Carriage 1/4-20 x 1-1/4
14	802392-49	Spacer
15	STD541025	* Nut, Hex 1/4-20
16	STD551025	* Washer, 17/64 x 5/8 x 1/32
17	STD522532	* Screw, Hex Hd. 1/4-20 x 3-1/4
18	823031	Plate, Deflector
19	STD511003	* Screw, Pan Hd. 10-24 x 3/8
20	823015	Spring, Compression
21	STD551131	* Lockwasher, Ext. 5/16
22	805517	Screw, Pan Hd. 5/16-18 x 1/2

Key No.	Part No.	Description
23	823007	Indicator, Blade Tilt
24	823005	Bracket, Indicator Support
25	823030	Spacer, 9.5 x 68.5
26	STD541031	* Nut Hex 5/16-18
27	STD833016	Screw, Hex Hd. M6 x 1-18
28	STD852006	* Lockwasher, M6
29	823018	Nut, Hex Special 3/8-16 x 5/32
30	823018-1	Nut, Hex Special 3/8-16 x 13/64
31	823019	Washer, Fiber 10mm
32	808447-7	Washer, Wave 10mm
33	823017	Bar, Rocker
34	823016	Spacer 6.2 x 16 x 3.1
35	820632-1	Ring, Retaining
36	823028	Bracket, Motor
37	823026	Motor (see Fig. 5)
38	9-32556	† Blade, 10" Chisel Tooth
39	60547	Collar Blade
40	820818	Nut, Saw Arbor
41	821733-290	Pin, Roll 8 x 90
42	823036	Plate, Mounting
43	823029	Screw, Cr. Pan Hd Shoulder
44	823997	Screw Pan Hd. Shoulder

Figure 3

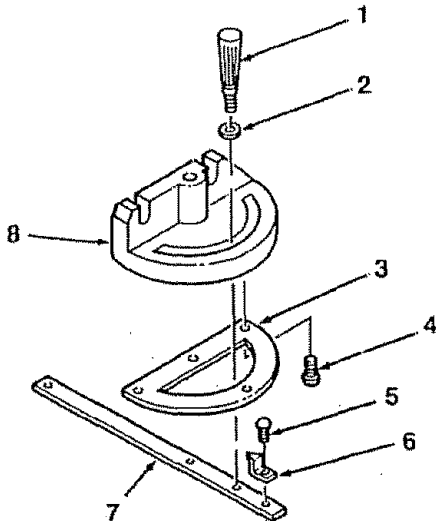

Key No.	Part No.	Description
1	823065	Knob Miter Gauge
2	60545	Washer, Nylon
3	823068	Pad, Sliding
4	823069	Screw, Flat Cr. Hd. Ty "TT" M4 x .7 x 8
5	STD510802	* Screw #8-32 x 1/4
6	823066	Indicator, Miter Gauge
7	823198	Bar, Miter Gauge
8	823157	Body, Miter Gauge

\* Standard Hardware Item - May be Purchased Locally

† Stock Item - May be secured through the hardware department of most Sears Retail Stores

# Repair Parts

## Parts List for Craftsman 10" Bench Top Table Saw Model No. 113.221740

Always Order by Part Number - Not Key Number

Figure 4

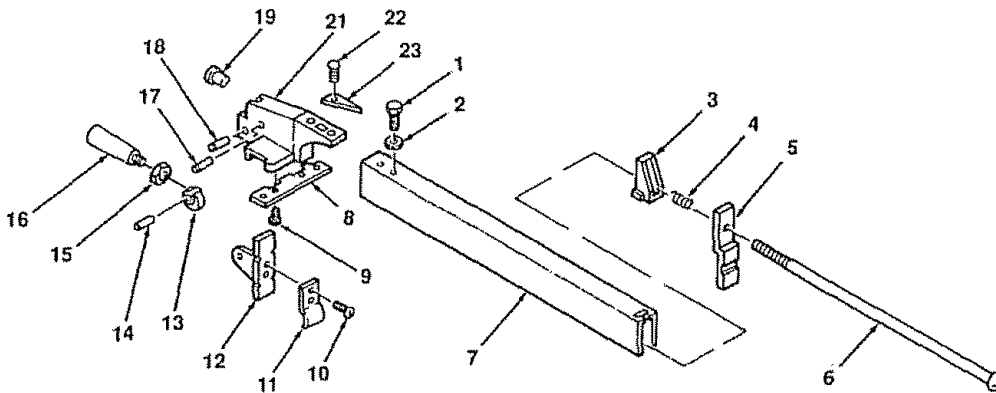

Key No.	Part No.	Description
1	STD522505	* Screw, Hex Hd. 1/4-20 x 1/2
2	STD551225	* Lockwasher, 1/4 Ext
3	823181	Rear Sliding Pad
4	823180	Compression Spring
5	823179	Rear Clamp
6	823178	Clamp Rod
7	823182	Fence
8	823187	Sliding Pad
9	823069	Screw Fl. Hd. Ty "TT" M4 x .7-8
10	STD510802	* Screw Cr. Pan #8-32 x 1/4
11	823190	Front Spring Clamp
12	823189	Bracket Fence Cam

Key No.	Part No.	Description
13	823186	Rip Fence Cam
14	821733-107	Pin Roll 3 x 22
15	STD541031	* Nut, Hex 5/16-18
16	823185	Rip Fence Handle
17	823191	Lever Pin
18	823188	Cam Pin
19	823193	Rear Clamp Screw
21	823183	Rip Fence Housing
22	STD510802	* Screw Cr. Pan #8-32 x 1/4
23	823184	Rip Fence Indicator

Figure 5

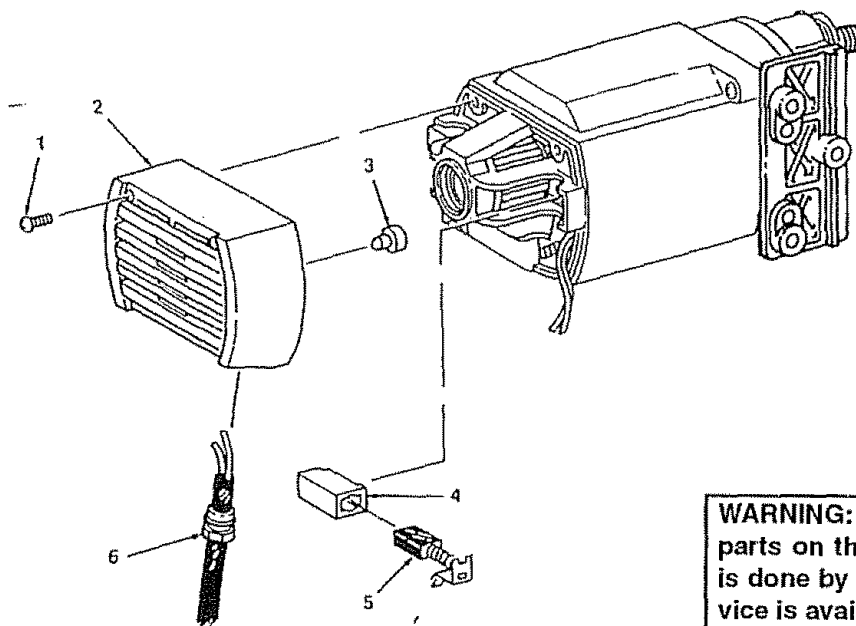

Key No.	Part No.	Description
—	823026	Motor (Complete)
1	46-57477-3	* Screw Pan Hd M4 x 0.7-12
2	821143	Cap End
3	821141	Pad - Brush
4	821139	Housing Brush
5	821140	Brush
6	169123-15	Relief - Strain

\* Standard Item - May be Purchased Locally

**WARNING:** Any attempt to repair or replace electrical parts on this unit may create a hazard unless repair is done by a qualified service technician. Repair service is available through your nearest Sears Store.



# Repair Parts

## Parts List for Craftsman 10" Bench Top Table Saw Model No. 113.221740

Always Order by Part Number - Not Key Number

Figure 6

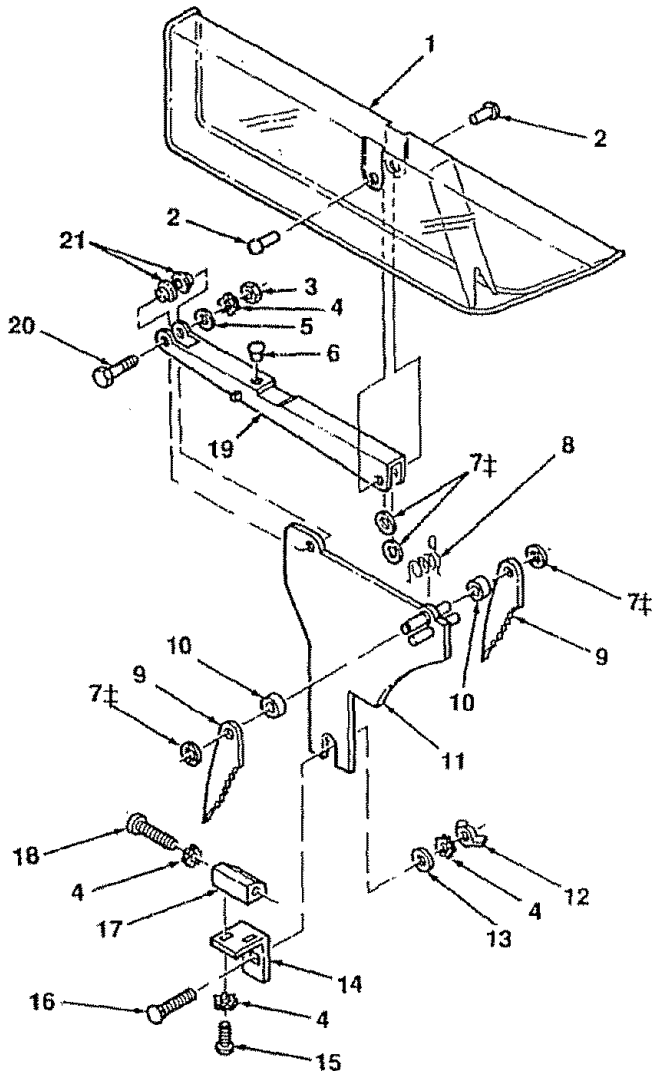

Key No	Part No.	Description
1	823196	Guard
2	823091	Rivet
3	STD541025	* Nut Hex 1/4-20
4	STD551225	* Lockwasher, Ext. 1/4
5	STD551012	* Flatwasher, 17/64 x 7/16 x 1/32
6	823089	Bumper Snap In
7	802612-13	‡Nut, Push 6mm
8	823096	Spring Torsion
9	822450	Pawl, Anti-kickback
10	823095	Spacer
11	823098	Spreader
12	STD541625	* Nut, Wing 1/4-20
13	STD551025	* Flatwasher, 17/64 x 5/8 x 1/32
14	823080	Bracket Asm., Spreader
15	STD522505	* Screw, Hex Hd 1/4-20 x 1/2
16	822489	Bolt, Carriage 1/4-20 x 7/8
17	823079	Support Spreader
18	STD522522	* Screw, Hex Hd. 1/4-20 x 2-1/4
19	823090	Bracket, Guard
20	STD522515	* Screw Hex Hd. 1/4-20 x 1-1/2
21	823088	Spacer

\* Standard Hardware Item - May be purchased locally.

‡ If this part is removed, discard and replace with a new push nut.

# SEARS

owner's  
manual

MODEL NO.  
113.221740

The model number of your table saw is found at the rear of the base.

When requesting service or ordering parts, always provide the following information:

- Product Type
- Model Number
- Part Number
- Part Description

## 10 INCH BENCH TOP TABLE SAW

For the repair or replacement parts you need

Call 7 am - 7 pm, 7 days a week

**1-800-366-PART**

(1-800-366-7278)

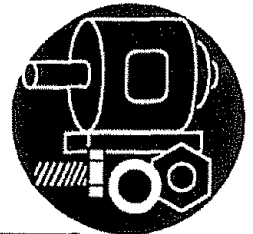

For in-home major brand repair service

Call 24 hours a day, 7 days a week

**1-800-4-REPAIR**

(1-800-473-7247)



For the location of a  
Sears Repair Service Center in your area

Call 24 hours a day, 7 days a week

**1-800-488-1222**



For information on purchasing a Sears  
Maintenance Agreement or to inquire  
about an existing Agreement

Call 9 am - 5 pm, Monday-Saturday

**1-800-827-6655**

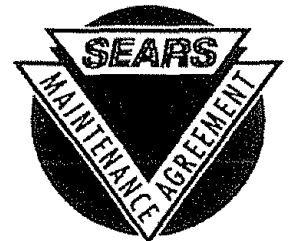

**SEARS**  
**REPAIR SERVICES**

*America's Repair Specialists*

Sears, Roebuck and Co., Hoffman Estates, IL. 60179 U.S.A.