



Refrigerator

With Automatic Freeze Control

Use & Care Guide

Refrigerador

con control automático de congelación

Guía para su uso y cuidado

Réfrigérateur

à régulateur de gel automatique

Guide d'utilisation et d'entretien



Sears, Roebuck and Co., Hoffman Estates, IL 60179 U.S.A.
Sears Canada, Inc., Toronto, Ontario, Canada M5B 2B8

www.sears.com
297088200 (0601)

ENGLISH

ESPAÑOL

FRANÇAIS

TABLE OF CONTENTS

Record Serial/Model Numbers	1
Safety	1-2
Warranty	3
First Steps	4-5
Energy Saving Tips	5
Setting the Temperature Control	5
Refrigerator Features	5
Care and Cleaning	6
Troubleshooting Guide	7-8
Sears Service	9
Sears Canada Customers	9

SERIAL / MODEL NUMBERS

READ AND SAVE THESE INSTRUCTIONS

This Owner's Guide provides specific operating instructions for your model. Use your refrigerator only as instructed in this guide. These instructions are not meant to cover every possible condition and situation that may occur. Common sense and caution must be practiced when installing, operating, and maintaining any appliance.

Record Your Model and Serial Numbers

Record the model and serial numbers in the space provided below. The serial plate is located on the upper left wall inside the refrigerator.

Model Number: 253.

or 970.

Serial Number: _____

Purchase Date: _____

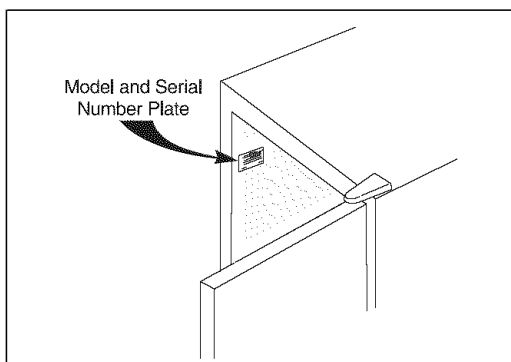

IMPORTANT SAFETY INSTRUCTIONS

READ ALL INSTRUCTIONS BEFORE USING THIS REFRIGERATOR.

⚠ WARNING FOR YOUR SAFETY

Do not store or use gasoline, or other flammable vapors and liquids in the vicinity of this or any other appliance. Read product labels for flammability and other warnings.

⚠ WARNING CHILD SAFETY

- Destroy carton, plastic bags, and any exterior wrapping material immediately after the refrigerator is unpacked. Children should never use these items to play. Cartons covered with rugs, bedspreads, plastic sheets or stretch wrap may become airtight chambers, and can quickly cause suffocation.
- Remove all staples from the carton. Staples can cause severe cuts, and destroy finishes if they come in contact with other appliances or furniture.
- An empty, discarded ice box, refrigerator, or freezer is a very dangerous attraction to children.
- Remove and discard any spacers used to secure the shelves during shipping. Small objects are a choke hazard to children.

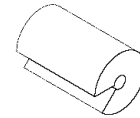

Remove the door(s) of any appliance that is not in use, even if it is being discarded.

Proper Disposal of Your Refrigerator/Freezer

⚠ WARNING Risk of child entrapment. Child entrapment and suffocation are not problems of the past. Junked or abandoned refrigerators or freezers are still dangerous — even if they will sit for "just a few days." If you are getting rid of your old refrigerator or freezer, please follow the instructions below to help prevent accidents.

BEFORE YOU THROW AWAY YOUR OLD REFRIGERATOR/FREEZER:

- Remove doors.
- Leave shelves in place so children may not easily climb inside.

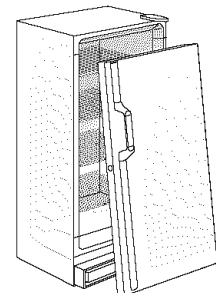

⚠ WARNING ELECTRICAL INFORMATION

These guidelines must be followed to ensure that safety mechanisms in the design of this refrigerator will operate properly.

- **Refrigerator must be plugged into its own 115 Volt, 60 Hz., AC only electric outlet.** The power cord of the appliance is equipped with a three-prong grounding plug for your protection against shock hazards. It must be plugged directly into a properly grounded three-prong receptacle. The receptacle must be installed in accordance with local codes and ordinances. Consult a qualified electrician. **Do not use an extension cord or adapter plug.**
- If voltage varies by 10% or more, performance of your refrigerator may be affected. Operating refrigerator with insufficient power can damage the compressor.
- To prevent the refrigerator from being turned off accidentally, do not plug unit into an outlet controlled by a wall switch or pull cord.
- Do not pinch, knot, or bend the cord in any manner.

⚠ WARNING OTHER PRECAUTIONS

- Never unplug the refrigerator by pulling on the cord. Always grip the plug firmly, and pull straight out from the receptacle.
- To avoid electrical shock, unplug the refrigerator before cleaning and before replacing a light bulb.

NOTE: Turning the temperature control to OFF turns off the compressor, but does not disconnect the power to the light bulb or other electrical components.

- Do not operate refrigerator in the presence of explosive fumes.

ENGLISH

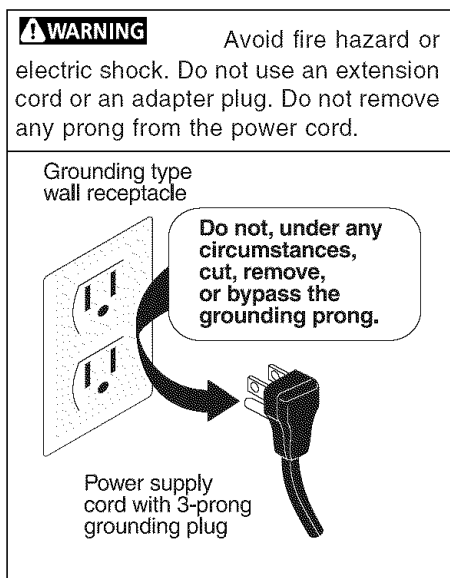

REFRIGERATOR WARRANTY

KENMORE APPLIANCE WARRANTY

One Year Limited Warranty

When installed, operated and maintained according to all instructions supplied with the product, if this appliance fails due to a defect in material or workmanship within one year from the date of purchase, call 1-800-4-MY-HOME® to arrange for free repair.

If this appliance is used for other than private family purposes, this warranty applies for only 90 days from the date of purchase.

This warranty covers only defects in material and workmanship. Sears will NOT pay for:

1. Expendable items that can wear out from normal use, including but not limited to filters, belts, light bulbs and bags.
2. A service technician to instruct the user in correct product installation, operation or maintenance.
3. A service technician to clean or maintain this product.
4. Damage to or failure of this product if it is not installed, operated or maintained according to all instructions supplied with the product.
5. Damage to or failure of this product resulting from accident, abuse, misuse or use for other than its intended purpose.
6. Damage to or failure of this product caused by the use of detergents, cleaners, chemicals or utensils other than those recommended in all instructions supplied with the product.
7. Damage to or failure of parts or systems resulting from unauthorized modifications made to this product.

Disclaimer of implied warranties; limitation of remedies

Customer's sole and exclusive remedy under this limited warranty shall be product repair as provided herein. Implied warranties, including warranties of merchantability or fitness for a particular purpose, are limited to one year or the shortest period allowed by law. Sears shall not be liable for incidental or consequential damages. Some states and provinces do not allow the exclusion or limitation of incidental or consequential damages, or limitations on the duration of implied warranties of merchantability or fitness, so these exclusions or limitations may not apply to you.

This warranty applies only while this appliance is used in the United States and Canada.

This warranty gives you specific legal rights, and you may also have other rights which vary from state to state.

Sears, Roebuck and Co., Dept. 817WA, Hoffman Estates, IL 60179

Sears Canada Inc., Toronto, Ontario, Canada M5B 2B8

FIRST STEPS

This Owner's Guide provides specific operating instructions for your model. Use the refrigerator only as instructed in this Owner's Guide. **Before starting the refrigerator, follow these important first steps.**

INSTALLATION

- Choose a place that is near a grounded electrical outlet. **Do Not** use an extension cord or an adapter plug.
- For the most efficient operation, the refrigerator should be located where surrounding temperatures will not drop below 10° F (-12° C) or exceed 110° F (43° C). The Freeze Control Feature is designed to automatically maintain the selected interior refrigerator temperature within these boundaries.
- *Allow space around the unit for good air circulation.* Leave a 3 inch (75 mm) space on all sides of the refrigerator for adequate circulation.

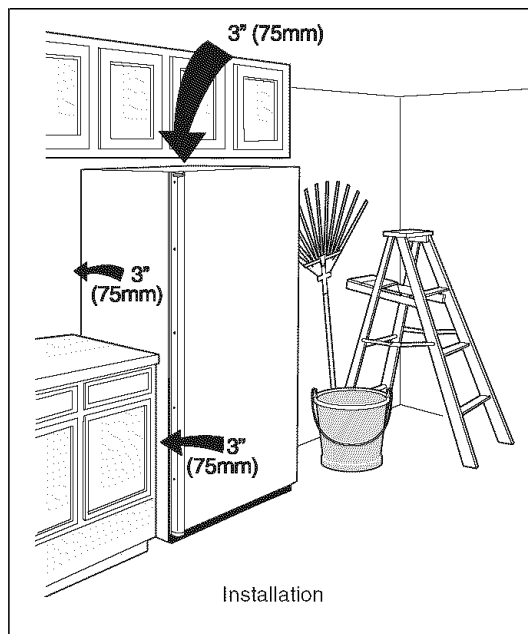

NOTE: The exterior walls of the refrigerator may become quite warm as the compressor works to transfer heat from the inside. Temperatures as much as 30° F warmer than room temperature can be expected. For this reason it is particularly important in hotter climates to allow enough space for air circulation around your refrigerator.

LEVELING

The refrigerator must have all bottom corners resting firmly on a solid floor. The floor must be strong enough to support a fully loaded refrigerator. **NOTE:** It is **Very Important** for your refrigerator to be level in order to function properly. If the refrigerator is not leveled during installation, the door may be misaligned and not close or seal properly, causing cooling, frost, or moisture problems.

To Level Your Refrigerator:

After discarding crating screws and wood base, use a carpenter's level to level the refrigerator from front-to-back. Adjust the plastic leveling feet in front, ½ bubble higher, so that the door closes easily when left halfway open.

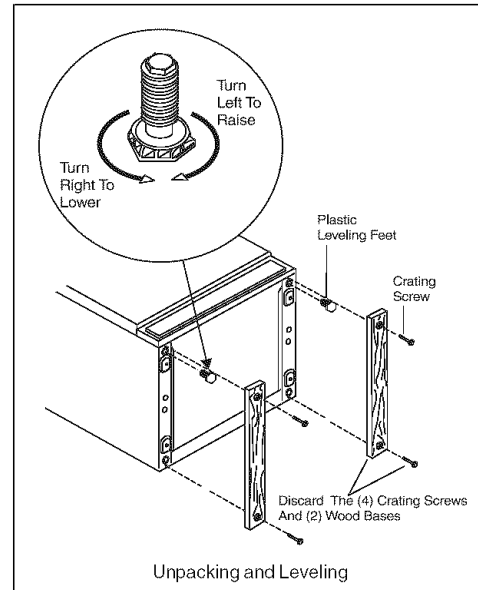

CLEANING

- Wash any removable parts of the refrigerator interior, and exterior with mild detergent and warm water. Wipe dry. **Do not use harsh cleaners on these surfaces.**
- Do not use razor blades or other sharp instruments, which can scratch the appliance surface when removing adhesive labels. Any glue left from the tape can be removed with a mixture of warm water and mild detergent, or touch the residue with the sticky side of tape already removed. **Do not remove the serial plate.**

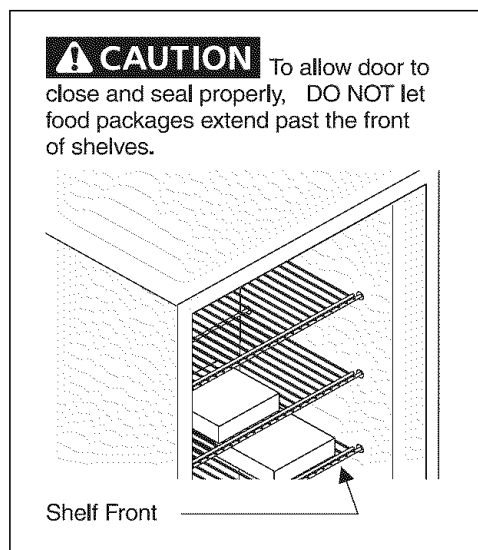

DOOR REMOVAL

If door must be removed :

1. Gently lay refrigerator on its back, on a rug or blanket.
2. Remove two base screws and base panel. Remove wire clips on bottom of cabinet.
3. Remove bottom hinge screws.
4. Remove plastic top hinge cover.
5. Remove screws from top hinge.
6. Remove top hinge from cabinet.
7. Remove door and bottom hinge from cabinet.
8. To replace door, reverse the above order and securely tighten all screws to prevent hinge slippage.

ENERGY SAVING TIPS



- Install the refrigerator in the coolest part of the room, out of direct sunlight and away from heating ducts or registers. Do not place the refrigerator next to heat-producing appliances such as a range, oven or dishwasher.
- Level the refrigerator so the doors close tightly.
- Do not overcrowd the refrigerator or block cold air vents. Doing so causes the refrigerator to run longer and use more energy. Shelves should not be lined with aluminum foil, wax paper or paper toweling. Liners interfere with cold air circulation, making the refrigerator less efficient, which could cause food spoilage.
- Cover foods and wipe containers dry before placing them in the refrigerator. This cuts down on moisture build-up inside the unit.
- Organize the refrigerator to reduce door openings. Remove as many items as needed at one time and close the door as soon as possible.

SETTING THE TEMPERATURE CONTROL

COOL DOWN PERIOD

For safe food storage, allow 4 hours for the refrigerator to cool down completely. The refrigerator will run continuously for the first several hours.

TEMPERATURE CONTROL

The temperature control is located inside the refrigerator compartment. The temperature is factory preset to provide satisfactory food storage temperatures. However, the temperature control is adjustable to provide a range of temperatures for your personal satisfaction. If a colder temperature is desired, turn the temperature control knob toward COLDEST and allow several hours for temperatures to stabilize between adjustments.

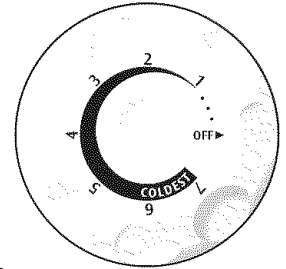

Cold Control

REFRIGERATOR FEATURES

INTERIOR LIGHT

The light comes on automatically when the door is opened. To replace the light bulb, turn the temperature control to OFF and **unplug the electrical cord**. Replace the old bulb with a bulb of the same wattage.

ADJUSTABLE INTERIOR SHELVES

Multi-position adjustable interior shelves can be moved to any position for larger or smaller packages. The shipping spacers that stabilize the shelves for shipping should be removed and discarded.

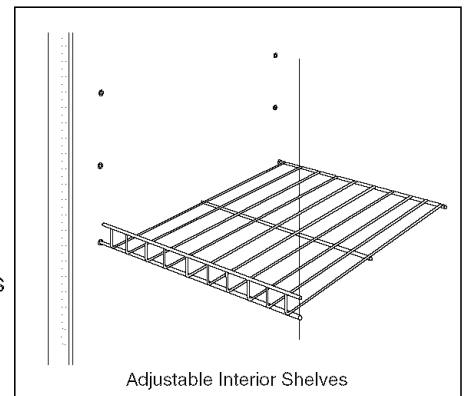

Adjustable Interior Shelves

AUTOMATIC FREEZE CONTROL

The Freeze Control Feature will maintain proper interior refrigerator temperature even when the refrigerator is placed in an area where the surrounding temperature drops down to 10° F (-12° C).

CARE AND CLEANING

⚠ WARNING If leaving the refrigerator door open while on vacation, make certain that children cannot get into the refrigerator and become entrapped.

CLEANING THE INSIDE

Wash inside surfaces of the refrigerator with a solution of two tablespoons of baking soda in one quart (1.136 litres) warm water. Rinse and dry. Wring excess water out of the sponge or cloth when cleaning in the area of the controls, or any electrical parts.

Wash the removable parts with the baking soda solution mentioned above, or mild detergent and warm water. Rinse and dry. **Never** use metallic scouring pads, brushes, abrasive cleaners, or alkaline solutions on any surface. Do not wash removable parts in a dishwasher.

CLEANING THE OUTSIDE

Wash the cabinet with warm water and mild liquid detergent. Rinse well and wipe dry with a clean soft cloth. Replace parts and food.

VACATION AND MOVING TIPS

Vacations:

If the refrigerator will not be used for several months:

- Remove all food and unplug the power cord.
- Clean and dry the interior thoroughly.
- Leave the refrigerator door open slightly, blocking it open if necessary, to prevent odor and mold growth.

Moving: When moving the refrigerator, follow these guidelines to prevent damage:

- Disconnect the power cord plug from the wall outlet.
- Remove foods and clean the refrigerator.
- Secure all loose items by taping them securely in place to prevent damage.
- In the moving vehicle, secure refrigerator in an upright position to prevent movement. Also protect outside of refrigerator with a blanket, or similar item.

TROUBLESHOOTING GUIDE		Before calling for service, review this list. It may save you time and expense. This list includes common occurrences that are not the result of defective workmanship or materials in this appliance.
PROBLEM	CAUSE	CORRECTION
REFRIGERATOR OPERATION		
Refrigerator does not run.	<ul style="list-style-type: none"> • Refrigerator is plugged into a circuit that has a ground fault interrupt. • Temperature control is in the OFF position. • Refrigerator may not be plugged in, or plug may be loose. • House fuse blown or tripped circuit breaker. • Power outage. 	<ul style="list-style-type: none"> • Use another circuit. If you are unsure about the outlet, have it checked by a certified technician. • See Setting the Temperature Control Section. • Ensure plug is tightly pushed into outlet. • Check/replace fuse with a 15 amp time-delay fuse. Reset circuit breaker. • Check house lights. Call local Electric Company.
Refrigerator runs too much or too long.	<ul style="list-style-type: none"> • Room or outside weather is hot. • Refrigerator has recently been disconnected for a period of time. • Large amounts of warm or hot food have been stored recently. • Doors are opened too frequently or too long. • Refrigerator door may be slightly open. • Temperature Control is set too low. • Refrigerator gasket is dirty, worn, cracked, or poorly fitted. 	<ul style="list-style-type: none"> • It's normal for the refrigerator to work harder under these conditions. • It takes 4 hours for the refrigerator to cool down completely. • Warm food will cause refrigerator to run more until the desired temperature is reached. • Warm air entering the refrigerator causes it to run more. Open doors less often. • See "DOOR PROBLEMS" Section. • Turn control knob to a warmer setting. Allow several hours for the temperature to stabilize. • Clean or change gasket. Leaks in the door seal will cause refrigerator to run longer in order to maintain desired temperature.
Interior refrigerator temperature is too cold.	<ul style="list-style-type: none"> • Temperature Control is set too low. 	<ul style="list-style-type: none"> • Turn the control to a warmer setting. Allow several hours for the temperature to stabilize.
Interior refrigerator temperature is too warm.	<ul style="list-style-type: none"> • Temperature Control is set too warm. • Door is kept open too long or is opened too frequently. • Door may not be seating properly. • Large amounts of warm or hot food may have been stored recently. • Refrigerator has recently been disconnected for a period of time. 	<ul style="list-style-type: none"> • Turn control to a colder setting. Allow several hours for the temperature to stabilize. • Warm air enters the refrigerator every time the door is opened. Open the door less often. • See "DOOR PROBLEMS" Section. • Wait until the refrigerator has had a chance to reach its selected temperature. • Refrigerator requires 4 hours to cool down completely.
Refrigerator external surface temperature is warm.	<ul style="list-style-type: none"> • The external refrigerator walls can be as much as 30°F warmer than room temperature. 	<ul style="list-style-type: none"> • This is normal while the compressor works to transfer heat from inside the refrigerator cabinet.
SOUND AND NOISE		
Louder sound levels whenever refrigerator is on.	<ul style="list-style-type: none"> • Modern refrigerators have increased storage capacity and more stable temperatures. They require a high efficiency compressor. 	<ul style="list-style-type: none"> • This is normal. When the surrounding noise level is low, you might hear the compressor running while it cools the interior.
Longer sound levels when compressor comes on.	<ul style="list-style-type: none"> • Refrigerator operates at higher pressures during the start of the ON cycle. 	<ul style="list-style-type: none"> • This is normal. Sound will level off or disappear as refrigerator continues to run.

PROBLEM	CAUSE	CORRECTION
SOUND AND NOISE (Cont.)		
Fan runs when room temperature is below 45°F.	<ul style="list-style-type: none"> Exterior thermostat has activated the heater and fan. 	<ul style="list-style-type: none"> This is normal.
Popping or cracking sound when compressor comes on.	<ul style="list-style-type: none"> Metal parts undergo expansion and contraction, as in hot water pipes. 	<ul style="list-style-type: none"> This is normal. Sound will level off or disappear as refrigerator continues to run.
Bubbling or gurgling sound, like water boiling.	<ul style="list-style-type: none"> Refrigerant (used to cool refrigerator) is circulating throughout the system. 	<ul style="list-style-type: none"> This is normal.
Vibrating or rattling noise.	<ul style="list-style-type: none"> Refrigerator is not level. It rocks on the floor when it is moved slightly. Refrigerator is touching the wall. 	<ul style="list-style-type: none"> Level the unit. Refer to "Leveling" in the First Steps Section. Relevel the refrigerator or move refrigerator slightly. Refer to "Leveling" in the First Steps Section.
Snapping Sound.	<ul style="list-style-type: none"> Cold Control turning the refrigerator on and off. 	<ul style="list-style-type: none"> This is normal.
WATER/MOISTURE/FROST INSIDE REFRIGERATOR		
Moisture forms on inside of refrigerator walls.	<ul style="list-style-type: none"> Weather is hot and humid. Door may not be seating properly. Door is kept open too long, or is opened too frequently. 	<ul style="list-style-type: none"> This is normal. See "DOOR PROBLEMS" Section. Open the door less often.
WATER/MOISTURE/FROST OUTSIDE REFRIGERATOR		
Moisture forms on outside of refrigerator.	<ul style="list-style-type: none"> Door may not be seating properly, causing the cold air from inside the refrigerator to meet warm moist air from outside. 	<ul style="list-style-type: none"> See "DOOR PROBLEMS" Section.
ODOR IN REFRIGERATOR		
Odors in refrigerator.	<ul style="list-style-type: none"> Interior needs to be cleaned. Foods with strong odors are in the refrigerator. 	<ul style="list-style-type: none"> Clean interior with sponge, warm water, and baking soda. Cover the food tightly.
DOOR PROBLEMS		
Door will not close.	<ul style="list-style-type: none"> Refrigerator is not level. It rocks on the floor when it is moved slightly. 	<ul style="list-style-type: none"> This condition can force the cabinet out of square and misalign the door. Refer to "Leveling" in the First Steps Section.
LIGHT BULB IS NOT ON		
Light bulb is not on.	<ul style="list-style-type: none"> Light bulb is burned out. No electric current is reaching the refrigerator. 	<ul style="list-style-type: none"> Follow directions under "Interior Light" in the Refrigerator Features Section. See "REFRIGERATOR OPERATION" Section.

SEARS SERVICE

"We Service What We Sell" is our assurance you can depend on Sears for service ...and Sears service is nationwide. Your refrigerator has added value when you consider that Sears has service units nationwide, staffed with professional technicians specifically trained on Sears appliances and having parts, tools and equipment to ensure that we meet our pledge to you..."We Service What We Sell."

SEARS MAINTENANCE AGREEMENT

Maintain the value of your *Kenmore®* refrigerator with a Sears Maintenance Agreement. Sears refrigerators are designed, manufactured, and tested for years of dependable operation. Yet, any modern appliance may require service from time to time.

The Sears Maintenance Agreement

- Is your way to buy tomorrow's service at today's price.
- Eliminates repair bills resulting from normal use.
- Allows for as many service calls as required.
- Provides for service by professional Sears-trained technicians.
- Offers an annual preventive maintenance check-up at your request.

This maintenance agreement does not cover original installation, reinstallation, or damage resulting from external causes such as acts of God, abuse, theft, fire, flood, wind, lightning, freezing, power failure, power reduction, etc. Please ask a salesperson to see the agreement for all of the terms and conditions.

SEARS CANADA CUSTOMERS

Dear Customer:

In manufacturing this product, many steps have been taken to provide you with the highest quality. Unfortunately, errors or omissions occasionally occur. In the event you find a missing or defective part, please contact your nearest Sears store. (See the back cover for phone numbers.)

If you have any suggestions that would help us to improve our assembly/operation instructions or this product, please write them down, including the information listed below and mail to:

**Sears Canada, Inc. Attn: Buyer Dept. 646
222 Jarvis Street
Toronto, Ontario
M5B 2B8**

Purchased by:

Name: _____

Address: _____

City: _____ Prov.: _____

Postal Code: _____ Phone: _____

Model No.: **970.** _____

Serial No.: _____

Date of Purchase ___/___/___

Location of Purchase _____

Comments: _____

ENGLISH