

Owner's Manual

CRAFTSMAN®

3/8 in. PROFESSIONAL ELECTRIC DRILL

Variable Speed / Reversible
Double Insulated

Model No.
315.271490

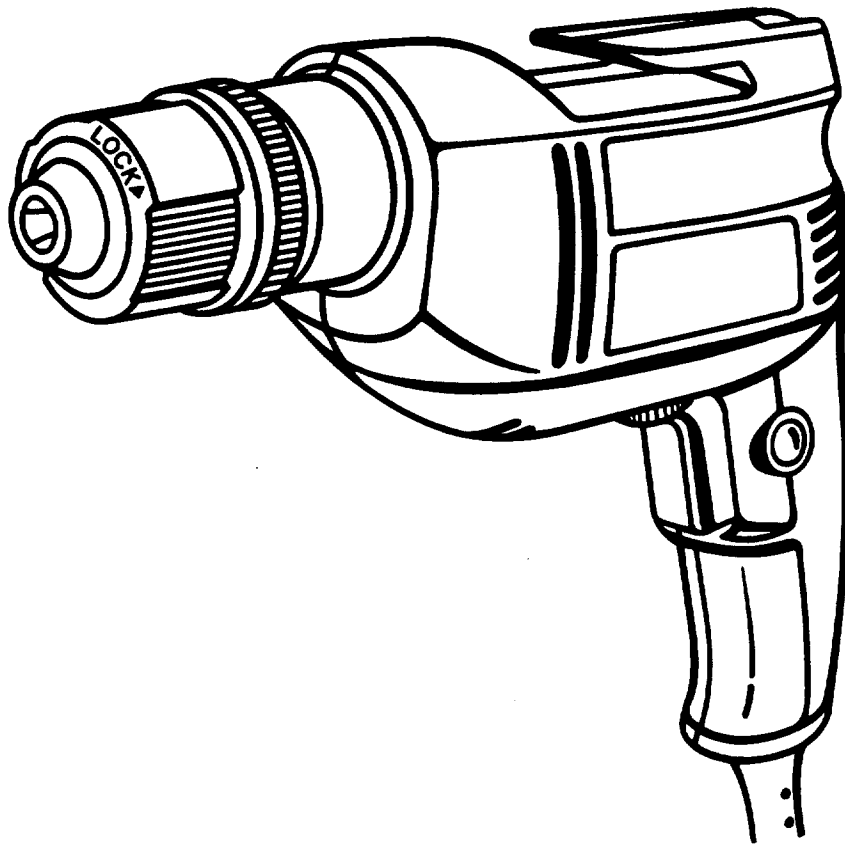

Save this manual for
future reference.

⚠ CAUTION: Read and follow
all Safety Rules and Operating
Instructions before first use of
this product.

Customer Help Line: 1-800-932-3188

Sears, Roebuck and Co., Hoffman Estates, IL 60179 USA
Visit the Craftsman web page: www.sears.com/craftsman

972000-551
8-98

- Safety
- Features
- Operation
- Maintenance
- Parts List



TABLE OF CONTENTS

■ Table Of Contents	2
■ Warranty	2
■ Introduction	2
■ Rules for Safe Operation	3-4
■ Product Specifications	5
■ Unpacking	5
■ Accessories	5
■ Features	6
■ Operation	7-10
■ Maintenance	11
■ Exploded View and Repair Parts List	13
■ Parts Ordering / Service	14

WARRANTY

FULL ONE YEAR WARRANTY ON CRAFTSMAN PROFESSIONAL ELECTRIC DRILL

If this **CRAFTSMAN** Drill fails due to a defect in material or workmanship within one year from the date of purchase, Sears will repair it, free of charge.

WARRANTY SERVICE IS AVAILABLE BY SIMPLY RETURNING THE TOOL TO THE NEAREST SEARS STORE IN THE UNITED STATES.

This warranty gives you specific legal rights, and you may also have other rights which vary from state to state; Sears, Roebuck and Co., Dept. 817WA, Hoffman Estates, IL 60179

INTRODUCTION

Your drill has many features for making drilling operations more pleasant and enjoyable. Safety, performance and dependability have been given top priority in the design of this drill making it easy to maintain and operate.

CAUTION: Carefully read through this entire owner's manual before using your new drill. Pay close attention to the Rules for Safe Operation, Warnings and Cautions. If you use your drill properly and only for what it is intended, you will enjoy years of safe, reliable service.

! Look for this symbol to point out important safety precautions. It means attention!!! Your safety is involved.

! WARNING:



The operation of any drill can result in foreign objects being thrown into your eyes, which can result in severe eye damage. Before beginning power tool operation, always wear safety goggles or safety glasses with side shields and a full face shield when needed. We recommend Wide Vision Safety Mask for use over eyeglasses or standard safety glasses with side shields, available at Sears Retail Stores.

RULES FOR SAFE OPERATION

The purpose of safety symbols is to attract your attention to possible dangers. The safety symbols, and the explanations with them, deserve your careful attention and understanding. The safety warnings do not by themselves eliminate any danger. The instructions or warnings they give are not substitutes for proper accident prevention measures.

SYMBOL MEANING



SAFETY ALERT SYMBOL:

Indicates danger, warning, or caution. May be used in conjunction with other symbols or pictographs.



DANGER: Failure to obey a safety warning will result in serious injury to yourself or to others. Always follow the safety precautions to reduce the risk of fire, electric shock and personal injury.



WARNING: Failure to obey a safety warning can result in serious injury to yourself or to others. Always follow the safety precautions to reduce the risk of fire, electric shock and personal injury.



CAUTION: Failure to obey a safety warning may result in property damage or personal injury to yourself or to others. Always follow the safety precautions to reduce the risk of fire, electric shock and personal injury.

NOTE: Advises you of information or instructions vital to the operation or maintenance of the equipment.

DOUBLE INSULATION

Double insulation is a concept in safety, in electric power tools, which eliminates the need for the usual three-wire grounded power cord. All exposed metal parts are isolated from internal metal motor components with protecting insulation. Double insulated tools do not need to be grounded.



WARNING: Do not attempt to operate this tool until you have read thoroughly and understand completely all instructions, safety rules, etc. contained in this manual. Failure to comply can result in accidents involving fire, electric shock, or serious personal injury. Save owner's manual and review frequently for continuing safe operation, and instructing others who may use this tool.

READ ALL INSTRUCTIONS

- **KNOW YOUR POWER TOOL.** Read owner's manual carefully. Learn its applications and limitations as well as the specific potential hazards related to this tool.
- **GUARD AGAINST ELECTRICAL SHOCK** by preventing body contact with grounded surfaces. For example; pipes, radiators, ranges, refrigerator enclosures.
- **KEEP GUARDS IN PLACE** and in working order.
- **KEEP WORK AREA CLEAN.** Cluttered areas and benches invite accidents.
- **AVOID DANGEROUS ENVIRONMENT.** Do not use power tools in damp or wet locations or expose to rain. Keep work area well lit.

IMPORTANT

Servicing of a tool with double insulation requires extreme care and knowledge of the system and should be performed only by a qualified service technician. For service we suggest you return the tool to your nearest Sears Store for repair. Always use original factory replacement parts when servicing.

- **KEEP CHILDREN AND VISITORS AWAY.** All visitors should wear safety glasses and be kept a safe distance from work area. Do not let visitors contact tool or extension cord.
- **STORE IDLE TOOLS.** When not in use, tools should be stored in a dry and high or locked-up place – out of the reach of children.
- **DO NOT FORCE TOOL.** It will do the job better and safer at the rate for which it was designed.
- **USE RIGHT TOOL.** Don't force small tool or attachment to do the job of a heavy duty tool. Don't use tool for purpose not intended — for example — don't use a circular saw for cutting tree limbs or logs.
- **WEAR PROPER APPAREL.** Do not wear loose clothing or jewelry that can get caught in tool's moving parts and cause personal injury. Rubber gloves and nonskid footwear are recommended when working outdoors. Wear protective hair covering to contain long hair and keep it from being drawn into nearby air vents.
- **ALWAYS WEAR SAFETY GLASSES.** Everyday eyeglasses have only impact-resistant lenses; they are not safety glasses.
- **PROTECT YOUR LUNGS.** Wear a face or dust mask if the operation is dusty.

RULES FOR SAFE OPERATION (Continued)

- **PROTECT YOUR HEARING.** Wear hearing protection during extended periods of operation.
- **DO NOT ABUSE CORD.** Never carry tool by cord or yank it to disconnect from receptacle. Keep cord from heat, oil, and sharp edges.
- **SECURE WORK.** Use clamps or a vise to hold work. It is safer than using your hand and it frees both hands to operate tool.
- **DO NOT OVERREACH.** Keep proper footing and balance at all times. Do not use on a ladder or unstable support. Secure tools when working at elevated positions.
- **MAINTAIN TOOLS WITH CARE.** Keep tools sharp and clean for best and safest performance. Follow instructions for lubricating and changing accessories.
- **DISCONNECT TOOLS.** When not in use, before servicing, or when changing attachments, tools should be disconnected from power supply.
- **REMOVE ADJUSTING KEYS AND WRENCHES.** Form habit of checking to see that keys and adjusting wrenches are removed from tool before turning it on.
- **AVOID ACCIDENTAL STARTING.** Do not carry plugged-in tool with finger on switch. Be sure switch is off when plugging in.
- **MAKE SURE YOUR EXTENSION CORD IS IN GOOD CONDITION.** When using an extension cord, be sure to use one heavy enough to carry the current your product will draw. An undersized cord will cause a drop in line voltage resulting in loss of power and overheating. A wire gage size (A.W.G.) of at least 16 is recommended for an extension cord 100 feet or less in length. A cord exceeding 100 feet is not recommended. If in doubt, use the next heavier gage. The smaller the gage number, the heavier the cord.
- **OUTDOOR USE EXTENSION CORDS.** When tool is used outdoors, use only extension cords suitable for use outdoors. Outdoor approved cords are marked with the suffix W-A, for example – SJTW-A or SJOW-A.
- **KEEP BITS CLEAN AND SHARP.** Sharp bits minimize stalling and kickback.
- **KEEP HANDS AWAY FROM DRILLING AREA.** Keep hands away from bits. Do not reach underneath work while bit is rotating. Do not attempt to remove material while bit is rotating.
- **NEVER USE IN AN EXPLOSIVE ATMOSPHERE.** Normal sparking of the motor could ignite fumes.
- **INSPECT TOOL CORDS PERIODICALLY** and if damaged, have repaired at your nearest Sears Repair Center. Stay constantly aware of cord location.
- **INSPECT EXTENSION CORDS PERIODICALLY** and replace if damaged.
- **KEEP HANDLES DRY, CLEAN, AND FREE FROM OIL AND GREASE.** Always use a clean cloth when cleaning. Never use brake fluids, gasoline, petroleum-based products, or any strong solvents to clean your tool.
- **STAY ALERT AND EXERCISE CONTROL.** Watch what you are doing and use common sense. Do not operate tool when you are tired. Do not rush.
- **CHECK DAMAGED PARTS.** Before further use of the tool, a guard or other part that is damaged should be carefully checked to determine that it will operate properly and perform its intended function. Check for alignment of moving parts, binding of moving parts, breakage of parts, mounting and any other conditions that may affect its operation. A guard or other part that is damaged should be properly repaired or replaced by an authorized service center.
- **DO NOT USE TOOL IF SWITCH DOES NOT TURN IT ON AND OFF.** Have defective switches replaced by an authorized service center.
- **DRILLING INTO ELECTRICAL WIRING IN WALLS CAN CAUSE DRILL BIT AND CHUCK TO BECOME ELECTRICALLY LIVE.** Do not touch the chuck or metal housing when drilling into a wall; grasp only the insulated handle provided on the tool.
- **INSPECT FOR** and remove all nails from lumber before drilling.
- **DO NOT** operate this tool while under the influence of drugs, alcohol, or any medication.
- **POLARIZED PLUGS.** To reduce the risk of electric shock, this tool has a polarized plug (one blade is wider than the other). This plug will fit in a polarized outlet only one way. If the plug does not fit fully in the outlet, reverse the plug. If it still does not fit, contact a qualified electrician to install the proper outlet. Do not change the plug in any way.
- **WHEN SERVICING USE ONLY IDENTICAL CRAFTSMAN REPLACEMENT PARTS.**
- **SAVE THESE INSTRUCTIONS.** Refer to them frequently and use them to instruct others who may use this tool. If you loan someone this tool, loan them these instructions also.

SAVE THESE INSTRUCTIONS

PRODUCT SPECIFICATIONS

Chuck Capacity	1/16 in. to 3/8 in.	Input	4.0 Amperes
Horsepower	1/2	No load speed	0-2500 RPM
Rating	120 volts, 60 Hz, AC only	Net weight	3.875 lbs.

UNPACKING

Your drill has been shipped completely assembled. Inspect it carefully to make sure no breakage or damage has occurred during shipping. If any parts are damaged or missing, contact your nearest Sears Retail Store to obtain replacement parts before attempting to operate drill. An owner's manual is included in the box.

 **WARNING:** If any parts are missing, do not operate this tool until the missing parts are replaced. Failure to do so could result in possible serious personal injury.

ACCESSORIES

The following recommended accessories are currently available at Sears Retail Stores.

- High Speed Bits (For wood or metal) 1/2 in. Max.
- Masonry Bits 3/4 in. Max.
- Wood Boring Bits 1 in. Max.
- Hole Saws 2 in. Max.
- Doweling Jig (9-4186)
- Drill Stand (9-25989)
- Wire Brushes, All

 **WARNING:** The use of attachments or accessories not listed above might be hazardous.

FEATURES

⚠ WARNING: Always wear safety goggles or safety glasses with side shields when operating your drill. Failure to do so could result in dust, shavings, loose particles or foreign objects being thrown into your eyes, causing possible serious injury.

KNOW YOUR ELECTRIC DRILL

See Figure 1.

Before attempting to use your drill, familiarize yourself with all operating features and safety requirements.

ELECTRICAL CONNECTION

Your drill has a precision built electric motor. It should be connected to a power supply that is 120 volts, 60 Hz, AC only (normal household current). Do not operate this tool on direct current (DC). A substantial voltage drop will cause a loss of power and the motor will overheat. If your drill does not operate when plugged into an outlet, double-check the power supply.

LOCK ON BUTTON

Your drill is equipped with a "lock-on" feature, which is convenient when continuous drilling for extended periods of time is required.

REVERSIBLE

Your drill has the feature of being reversible. The design of the switch will not permit changing the direction of rotation while the drill is running.

KEYLESS CHUCK

Your new drill has a keyless chuck. As the name implies, you can hand tighten or release drill bits in the chuck jaws.

VARIABLE SPEED

Your drill has a variable speed switch designed to allow operator control of speed and torque limits. The speed and torque of your drill can be increased by depressing the switch trigger.

LEVEL AND BELT CLIP

Two convenient features provided on your drill are a level and a belt clip. The level is recessed in the motor housing on your drill. It can be used to keep drill bits level during both horizontal and vertical drilling operations. The belt clip is molded into the top of the motor housing on your drill.

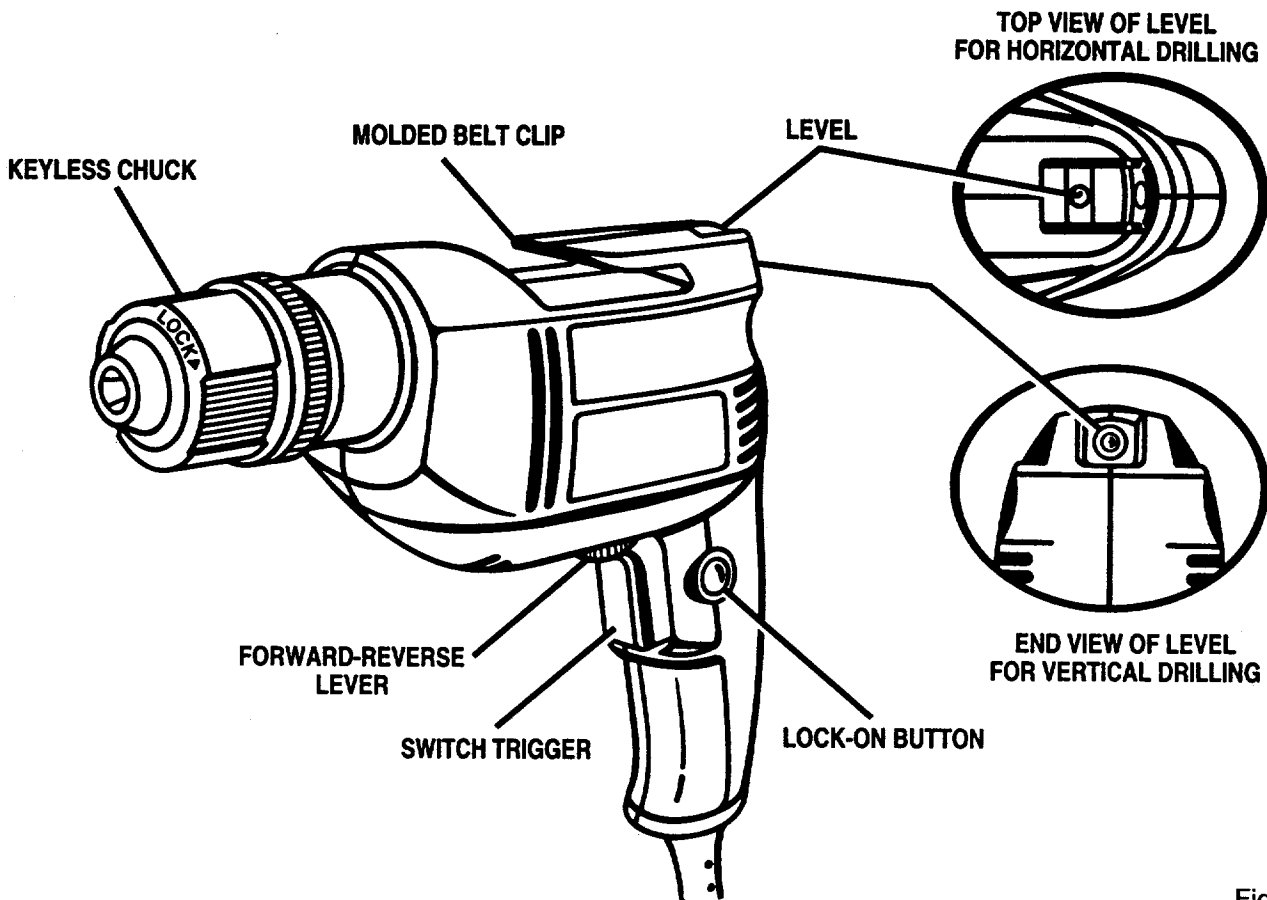

Fig. 1

⚠ WARNING: Do not allow familiarity with your drill to make you careless. Remember that a careless fraction of a second is sufficient to inflict severe injury.

OPERATION

⚠ WARNING: Your drill should never be connected to power supply when you are assembling parts, making adjustments, installing or removing drill bits, cleaning, or when not in use. Disconnecting your drill will prevent accidental starting that could cause serious personal injury.

SWITCH

See Figure 2.

To turn your drill **ON**, depress the switch trigger. Release switch trigger to turn your drill **OFF**.

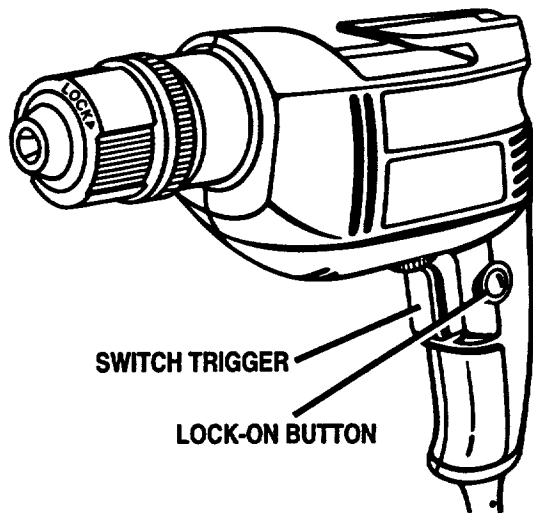

Fig. 2

LOCK-ON BUTTON

See Figure 2.

Your drill is equipped with a lock-on feature, which is convenient when continuous drilling for extended periods of time is required. To lock-on, depress the switch trigger, push in and hold the lock-on button located on the side of the handle, then release switch trigger. Release lock-on button and your drill will continue running.

To release the lock, depress the switch trigger and release.

If you have the lock-on feature engaged during use and your drill becomes disconnected from power supply, disengage the lock-on feature immediately.

KEYLESS CHUCK

See Figure 3.

Your new drill has a keyless chuck. As the name implies, you can hand tighten or release drill bits in the chuck jaws. Grasp and hold the collar of the chuck with one hand. Rotate the chuck body with your other hand. The arrows on the chuck indicate which direction to rotate the chuck body in order to **LOCK** (tighten) or **UNLOCK** (release) the drill bit.

Note: Closing chuck jaws completely without a drill bit inserted could cause premature failure of the chuck.

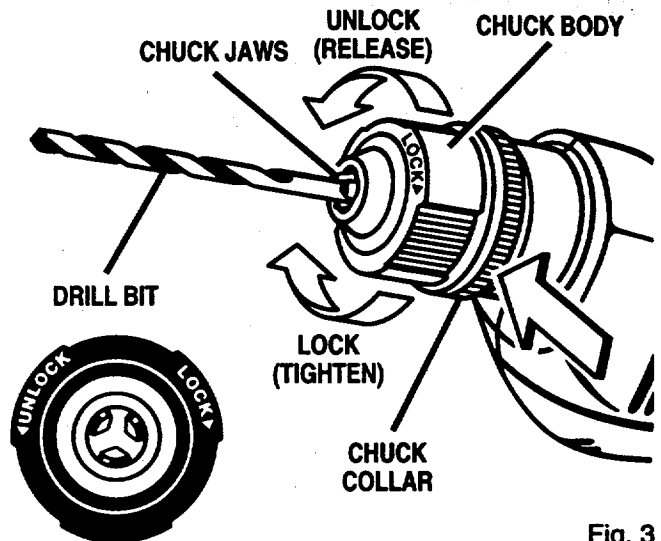

Fig. 3

⚠ WARNING: Do not hold the chuck body with one hand and use the power of your drill to tighten the chuck jaws on drill bits. The chuck body could slip in your hand or your hand could slip and come in contact with a rotating drill bit. This could cause an accident resulting in serious personal injury.

REVERSIBLE

See Figure 4.

Your electric drill has the feature of being reversible. The direction of chuck rotation is controlled by a lever located above the switch trigger. With your drill held in normal operating position, the direction of rotation lever should be positioned to the left of the switch for drilling. The drill direction is reversed when the lever is to the right of the switch.

The design of the switch will not permit changing the direction of rotation while the drill is running. Release the switch trigger and allow the drill to stop before changing its direction.

Note: Your drill will not run unless the switch lever is pushed fully to the left or right.

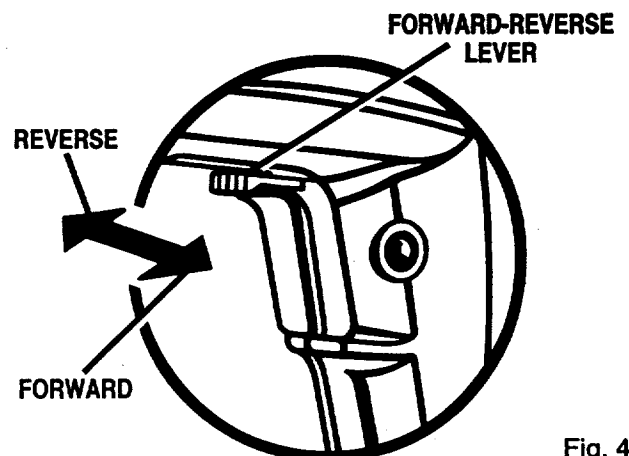

Fig. 4

OPERATION

VARIABLE SPEED

See Figure 5.

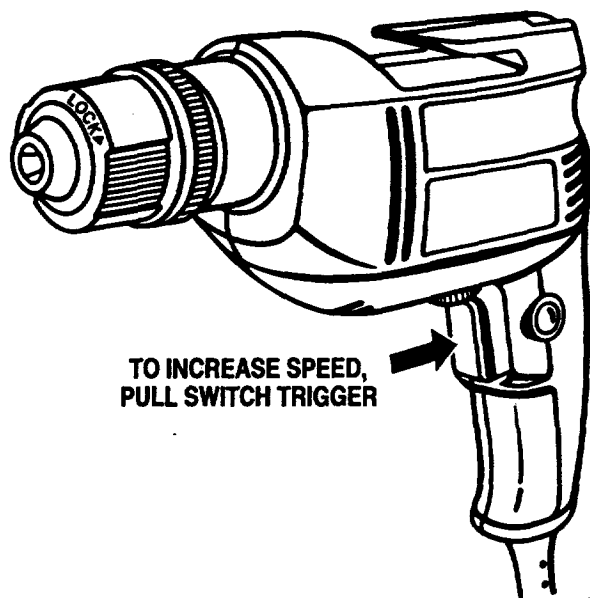

Fig. 5

Your drill has a variable speed switch designed to allow operator control of speed and torque limits. The speed and torque of your drill can be increased by depressing the switch trigger.

Note: Depress switch trigger all the way for maximum speed and torque of your drill. Depress switch trigger only part of the way for less speed and torque.

Avoid running your drill at low speeds for extended periods of time. Running at low speeds under constant usage may cause your drill to become overheated. If this occurs, cool your drill by running it without a load and at full speed.

The following guidelines may be used in determining correct speed for various applications:

- **LOW** speed is ideal when minimum speed and power is required. For example, starting holes without center punching, driving screws, mixing paint, and drilling in ceramics.
- **MEDIUM** speed is suitable for drilling hard metals, plastics, and laminates.
- **HIGH** speed produces best results when maximum power is required. For example, drilling in wood; soft metals such as aluminum, brass, and copper, and when using driving accessories.

⚠ WARNING: Your drill should never be connected to power supply when you are assembling parts, making adjustments, installing or removing drill bits, cleaning, or when not in use. Disconnecting your drill will prevent accidental starting that could cause serious personal injury.

TO INSTALL BITS

See Figure 6.

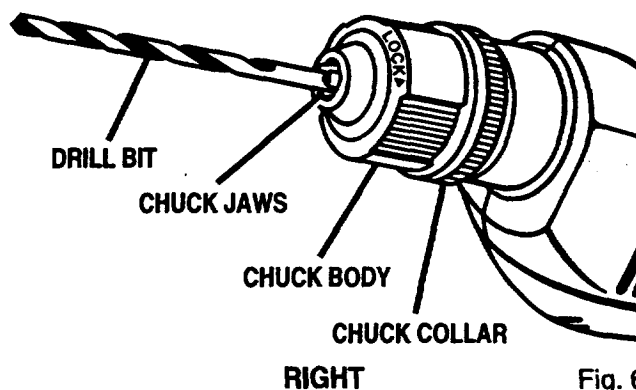

Fig. 6

- Unplug your drill.

⚠ WARNING: Failure to unplug your drill could result in accidental starting causing serious injury.

- Open or close the chuck jaws to a point where the opening is slightly larger than the drill bit you intend to use. Also, raise the front of your drill slightly to keep the drill bit from falling out of the chuck jaws.
- Insert drill bit into chuck the full length of the jaws.

⚠ WARNING: Do not insert drill bit into chuck jaws and tighten as shown in figure 7. This could cause drill bit to be thrown from your drill resulting in possible serious personal injury or damage to your chuck.

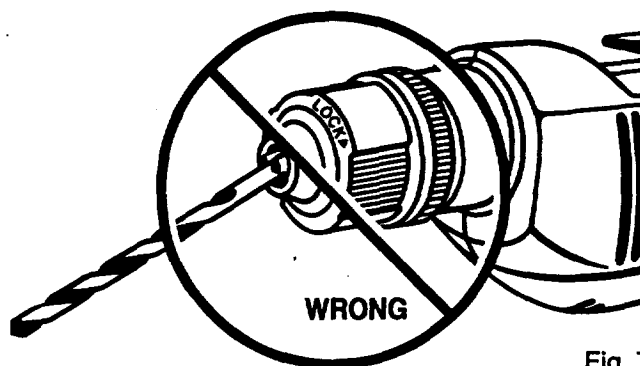

Fig. 7

- Tighten the chuck jaws on drill bit.
 - To tighten: grasp and hold the collar of the chuck with one hand, while rotating the chuck body with your other hand.
- Note:** Rotate the chuck body in the direction of the arrow marked **LOCK** to tighten chuck jaws.
- Do not use a wrench to tighten or loosen the chuck jaws.

TO REMOVE BITS

- Unplug your drill.

⚠ WARNING: Failure to unplug your drill could result in accidental starting causing serious injury.

- Loosen the chuck jaws from drill bit.
- To loosen: grasp and hold the collar of the chuck with one hand, while rotating chuck body with your other hand.
- **Note:** Rotate the chuck body in the direction of the arrow marked **UNLOCK** to loosen chuck jaws.
- **Do not** use a wrench to tighten or loosen the chuck jaws.
- Remove drill bit from chuck jaws.

DRILLING

See Figures 8 and 9.

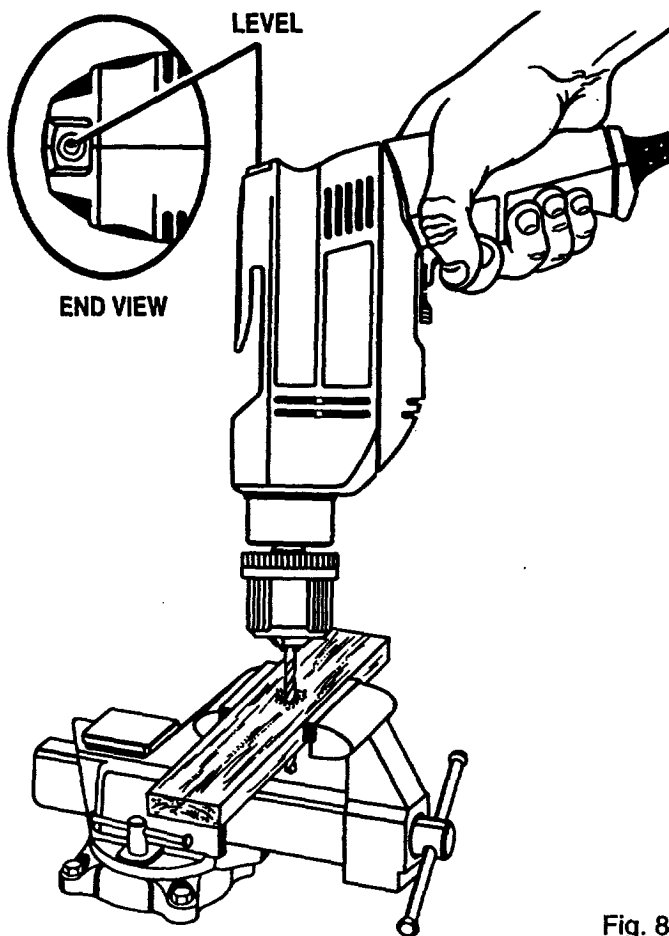

Fig. 8

- Depress and release switch trigger to be sure your drill is in **OFF** position before connecting it to power supply.
- Check the direction of rotation lever for correct setting (forward or reverse). See Figure 4.
- Secure the material to be drilled in a vise or with clamps to keep it from turning as the drill bit rotates.
- Plug your drill into power supply source.
- Hold your drill firmly and place bit at point to be drilled.
- Depress the switch trigger to start your drill. Do not lock the switch **ON** for jobs where your drill may need to be stopped suddenly.
- Move the drill bit into the workpiece applying only enough pressure to keep the bit cutting. Do not force your drill or apply side pressure to elongate a hole. Let your drill and bit do the work. See Figures 8 and 9.

⚠ WARNING: Be prepared for binding or bit breakthrough. When these situations occur, drill has a tendency to grab and kick opposite to the direction of rotation and could cause loss of control when breaking through materials. If not prepared, this loss of control can result in possible serious injury.

When drilling hard, smooth surfaces use a center punch to mark the desired hole location. This will prevent the drill bit from slipping off center as the hole is started. However, the variable speed feature allows starting holes without center punching if desired. To accomplish this, operate your drill at a low speed until the hole is started.

When drilling metals use a light oil on the drill bit to keep it from overheating. The oil will prolong the life of the bit and increase the drilling action.

If the bit jams in the work piece or if your drill stalls, stop the tool immediately. Remove the bit from the work piece and determine the reason for jamming.

LEVEL DRILLING

See Figures 8 and 9.

A convenient feature provided with your drill is a level. It is recessed in the motor housing on your drill. It can be used to keep drill bits level during both horizontal and vertical drilling operations.

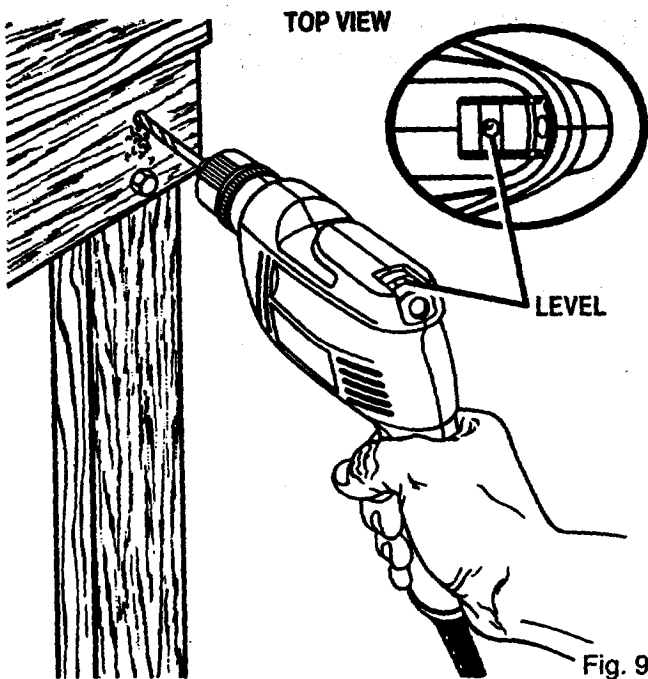

Fig. 9

CHUCK REMOVAL

See Figure 10, 11, and 12.

The chuck must be removed in order to use some accessories. To remove:

- Unplug your drill.

⚠ WARNING: Failure to unplug your drill could result in accidental starting causing serious injury.

- Insert a 8 mm (5/16 in.) or larger hex key wrench into the chuck and tighten the chuck jaws securely.
- Tap the hex key wrench sharply with a mallet in a clockwise direction. See Figure 10. This will loosen the screw in the chuck for easy removal.

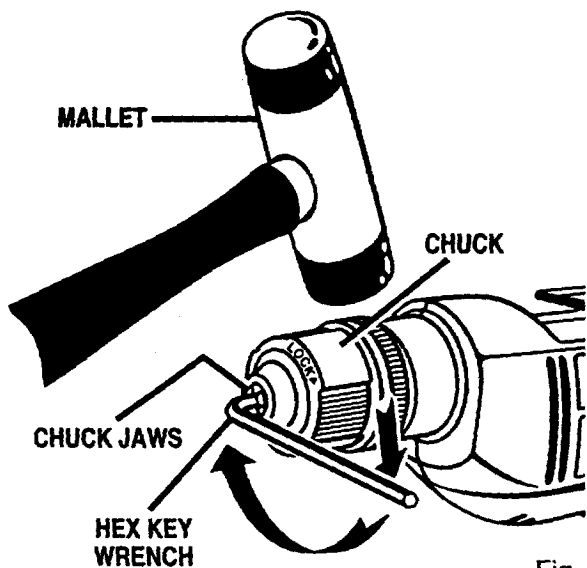

Fig. 10

- Open the chuck jaws and remove hex key wrench. Remove the chuck screw by turning it in a clockwise direction. See Figure 11.

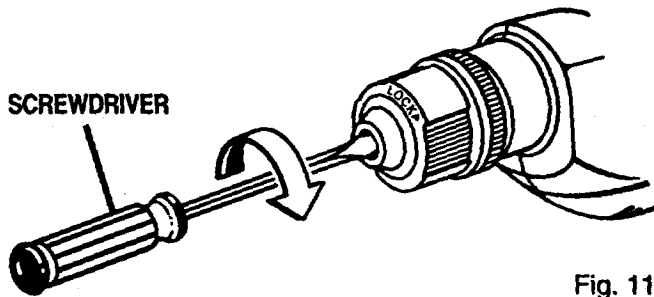

Fig. 11

Note: The chuck screw has left hand threads.

- Insert hex key wrench into chuck and tighten chuck jaws securely. Tap sharply with a mallet in a counterclockwise direction. This will loosen the chuck on the spindle. It can now be unscrewed by hand. See Figure 12.

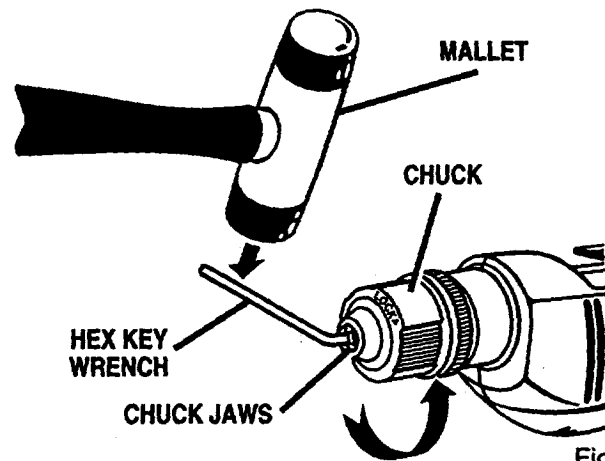



Fig. 12

The chuck may at times become loose on the spindle and develop a wobble. Also, the chuck screw may become loose causing the chuck jaws to bind and prevent them from closing. To tighten, follow these steps:

- Unplug your drill.
- ⚠ **WARNING:** Failure to unplug your drill could result in accidental starting causing serious injury.
- Insert hex key wrench into chuck and tighten chuck jaws securely. Tap hex key wrench sharply with a mallet in a clockwise direction. This will tighten the chuck on the spindle.
- Open the chuck jaws and remove the hex key wrench.
- Tighten the chuck screw.

Note: The chuck screw has left hand threads.

MAINTENANCE

 **WARNING:** When servicing, use only identical Craftsman replacement parts. Use of any other part may create a hazard or cause product damage.

GENERAL

Only the parts shown on parts list, page 13, are intended to be repaired or replaced by the customer. All other parts represent an important part of the double insulation system and should be serviced only by a qualified Sears service technician.

Avoid using solvents when cleaning plastic parts. Most plastics are susceptible to damage from various types of commercial solvents and may be damaged by their use. Use clean cloths to remove dirt, carbon dust, etc.

 **WARNING:** Do not at any time let brake fluids, gasoline, petroleum-based products, penetrating oils, etc. come in contact with plastic parts. They contain chemicals that can damage, weaken or destroy plastic.

It has been found that electric tools are subject to accelerated wear and possible premature failure when they are used on fiberglass boats, sports cars, wallboard, spackling compounds, or plaster. The chips and grindings from these materials are highly abrasive to electric tool parts such as bearings, brushes, commutators, etc. Consequently, it is not recommended that this tool be used for extended work on any fiberglass material, wallboard, spackling compounds, or plaster. During any use on these materials it is extremely important that the tool is cleaned frequently by blowing with an air jet.

 **WARNING:** Always wear safety goggles or safety glasses with side shields during power tool operation or when blowing dust. If operation is dusty, also wear a dust mask.

LUBRICATION

All of the bearings in this tool are lubricated with a sufficient amount of high grade lubricant for the life of the unit under normal operating conditions. Therefore, no further lubrication is required.

EXTENSION CORDS

The use of any extension cord will cause some loss of power. To keep the loss to a minimum and to prevent tool overheating, use an extension cord that is heavy enough to carry the current the tool will draw.

A wire gage size (A.W.G.) of at least 16 is recommended for an extension cord 100 feet or less in length. When working outdoors, use an extension cord that is suitable for outdoor use. The cord's jacket will be marked **WA**.

 **CAUTION:** Keep extension cords away from the drilling area and position the cord so that it will not get caught on lumber, tools, etc., during drilling operation.

 **WARNING:** Check extension cords before each use. If damaged, replace immediately. Never use tool with a damaged cord since touching the damaged area could cause electrical shock resulting in serious injury.

Extension cords suitable for use with your drill are available at your nearest Sears Retail Store.

**CRAFTSMAN 3/8 in. PROFESSIONAL ELECTRIC DRILL
MODEL NO. 315.271490**

The model number will be found on a plate attached to the motor housing. Always mention the model number in all correspondence regarding your **ELECTRIC DRILL** or when ordering repair parts.

SEE BACK PAGE FOR PARTS ORDERING INSTRUCTIONS

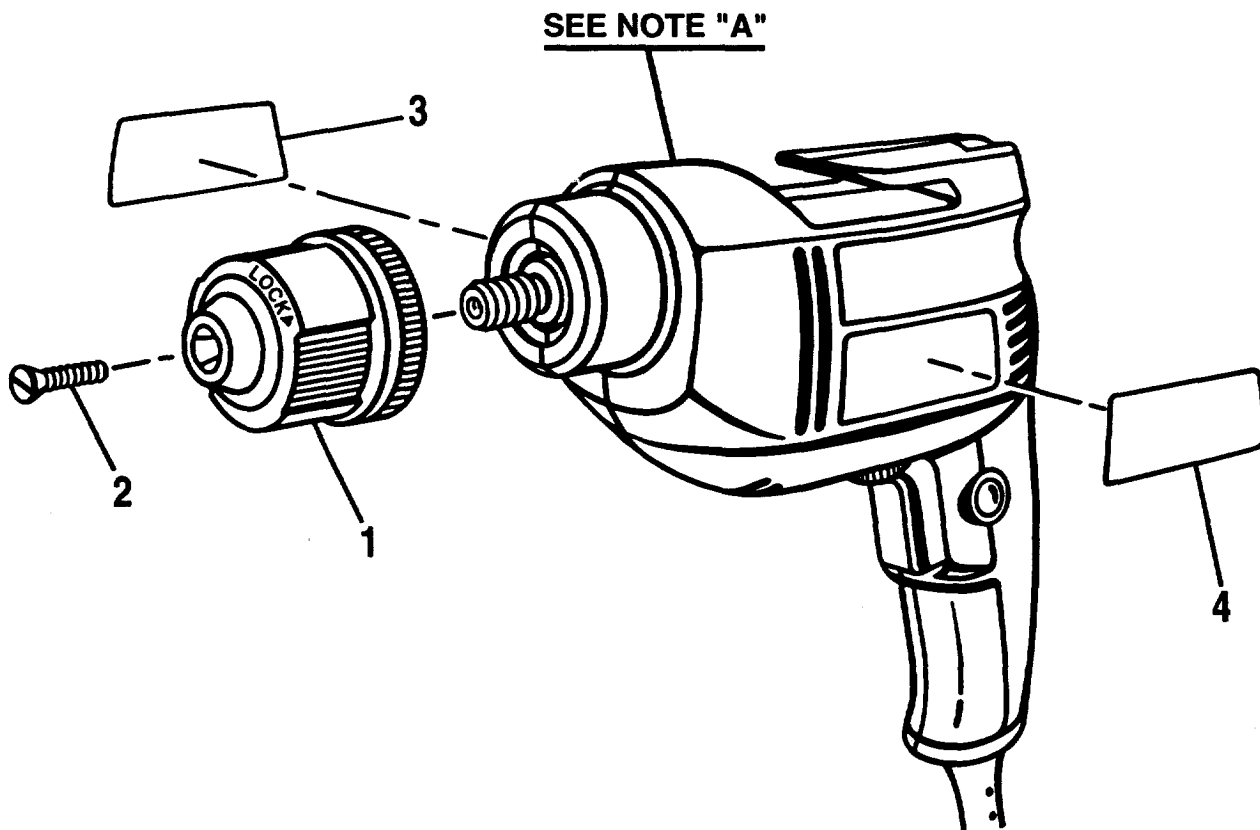

PARTS LIST

Key No.	Part No.	Description	Quan.
1	973093-001	3/8 in. Chuck (Item No. 9-20988)	1
2	616478-003	Screw (Special)	1
3	971763-001	Data Plate	1
4	979709-001	Logo Plate	1
	972000-551	Owner's Manual	

NOTE: "A"— The assembly shown represents an important part of the Double Insulated System. To avoid the possibility of alteration or damage to the system, service should be performed by your nearest Sears Repair Center. Contact your nearest Sears Retail Store for Service Center information.

For in-home major brand repair service:

Call 24 hours a day, 7 days a week

1-800-4-MY-HomeSM (1-800-469-4663)

Para pedir servicio de reparación a domicilio – 1-800-676-5811

In Canada for all your service and parts needs call
Au Canada pour tout le service ou les pièces – **1-800-665-4455**

For the repair or replacement parts you need:

Call 7 am – 7 pm, 7 days a week

1-800-366-PART (1-800-366-7278)

Para ordenar piezas con entrega a domicilio – 1-800-659-7084

For the location of a Sears Parts and Repair Center in your area:

Call 24 hours a day, 7 days a week

1-800-488-1222

**For information on purchasing a Sears Maintenance Agreement
or to inquire about an existing Agreement:**

Call 9 am – 5 pm, Monday – Saturday

1-800-827-6655



The Service Side of SearsSM