

Installation Instructions

36" Glass Canopy
Chimney Vent Hood

ZV900



Monogram®

Drill 2 (two) 3/16" pilot holes through studs or rear wall support

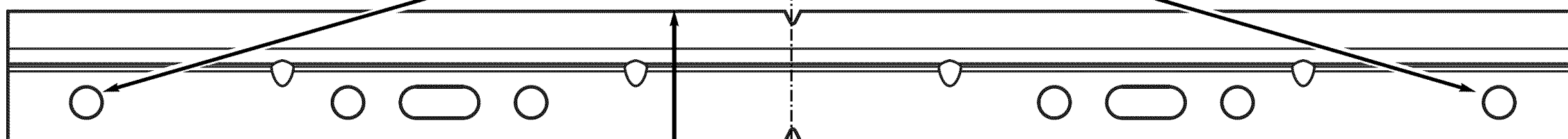

14-5/8"
to top of
bracket

C

REAR WALL MOUNTING TEMPLATE

ALIGN BOTTOM EDGE
WITH PENCIL LINE,
INDICATING BOTTOM
OF THE HOOD

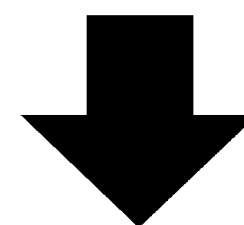

Safety Information

BEFORE YOU BEGIN

Read these instructions completely and carefully.

- **IMPORTANT** — Save these instructions for local inspector's use.
- **IMPORTANT** — Observe all governing codes and ordinances.
- **Note to Installer** — Be sure to leave these instructions with the Consumer.
- **Note to Consumer** — Keep these instructions with your Owner's Manual for future reference.
- **Skill Level** — Installation of this appliance requires basic mechanical and electrical skills.
- **Completion Time** — 1 to 3 Hours.
- Proper installation is the responsibility of the installer. Product failure due to improper installation is not covered under the warranty.

For Monogram local service in your area, call 1.800.444.1845.

For Monogram service in Canada, call 1.888.880.3030
For Monogram Parts and Accessories, call 1.800.626.2002.

CAUTION:

Due to the weight and size of these vent hoods and to reduce the risk of personal injury or damage to the product, **TWO PEOPLE ARE REQUIRED FOR PROPER INSTALLATION.**

PRUDENCE :

À cause du poids et de la taille de ces hottes et pour réduire le risque de blessures et de dommages, **IL FAUT DEUX PERSONNES POUR FAIRE L'INSTALLATION CORRECTEMENT.**

WARNING:

To reduce the risk of fire or electrical shock, do not use this range hood with any external solid-state speed control device. Any such alteration from original factory wiring could result in damage to the unit and/or create an electrical safety hazard.

AVERTISSEMENT :

Pour réduire le risque d'incendie ou de choc électrique, il ne faut pas utiliser cette hotte avec un régulateur de vitesse électronique externe. Toute modification de ce type du branchement d'usine peut endommager l'appareil ou créer un risque de choc électrique.

TO REDUCE THE RISK OF FIRE, USE ONLY METAL DUCTWORK.

WARNING: TO REDUCE THE RISK OF FIRE, ELECTRICAL SHOCK OR INJURY TO PERSONS, OBSERVE THE FOLLOWING:

- A. Use this unit only in the manner intended by the manufacturer. If you have any questions, contact the manufacturer.
- B. Before servicing or cleaning unit, switch power off at the service panel and lock service panel to prevent power from being switched on accidentally. If the service panel cannot be locked, fasten a tag or prominent warning label to the panel.

AVERTISSEMENT :

POUR RÉDUIRE LE RISQUE D'INCENDIE, DE CHOC ÉLECTRIQUE OU DE BLESSURES, IL FAUT OBSERVER LES REGLES SUIVANTES :

- A. Utiliser cet appareil uniquement de la manière prévue par le fabricant. En cas de question, consulter le fabricant.
 - B. Avant toute intervention ou nettoyage, couper l'alimentation électrique au disjoncteur et verrouiller le panneau du disjoncteur pour éviter la mise sous tension accidentelle. S'il n'est pas possible de verrouiller le panneau du disjoncteur, attacher un placard ou une étiquette très visible au panneau.
- For general ventilating use only. Do not use to exhaust hazardous or explosive materials or vapors.
 - Structural framing, installation work and electrical wiring must be done by qualified person(s) in accordance with all applicable codes and standards including fire-rated construction.
 - Sufficient air is needed for proper combustion and exhausting of gases through the flue (chimney) of fuel burning equipment to prevent back drafting. Follow the heating equipment manufacturer's guidelines and safety standards such as those published by the National Fire Protection Association (NFPA), and the American Society for Heating, Refrigeration and Air Conditioning Engineers (ASHRAE), and the local code authorities.
 - Local codes vary. Installation of electrical connections and grounding must comply with applicable codes. In the absence of local codes, the vent should be installed in accordance with National Electrical Code ANSI/NFPA 70-1990 or latest edition.

CAUTION: To reduce risk of fire and to properly exhaust air, be sure to duct air outside—do not vent exhaust air into spaces within walls or ceilings or into attics, crawl spaces or garages.

PRUDENCE : Il faut prendre soin d'installer un conduit vers l'extérieur pour réduire le risque d'incendie et pouvoir évacuer l'air correctement. Il ne faut pas évacuer l'air dans l'espace entre les parois d'un mur, un plafond ou un grenier, un espace sanitaire ou un garage.

Design Information

CONTENTS

Design Information

Product Dimensions and Clearances	3
Installation Options	3

Installation Preparation

Advance Planning, Ductwork, Framing	4
Power Supply	4
Duct Fittings	5
Tools and Materials Required	6
Remove the Packaging	6
Determine Installation Height	7
Wall Mount Installation Heights	7
Check Installation Hardware.....	8

Installation—Vented to the Outside

Step 1, Install Framing for Hood Support	9
Step 2, Install Mounting Bracket.....	10
Step 3, Install Duct Bracket.....	10
Step 4, Prepare the Hood.....	11
Step 5, Mount the Hood	12
Step 6, Level the Hood.....	12
Step 7, Connect Ductwork.....	12
Step 8, Connect Electrical	13
Step 9, Install Duct Covers.....	14
Step 10, Install Filters	14
Step 11, Finalize Installation	14

Installation—Recirculating

Ductwork, Wiring Locations	15
Step 1, Install Framing for Hood Support.....	15
Step 2, Install Mounting Bracket.....	16
Step 3, Install Duct Bracket.....	16
Step 4, Prepare the Hood.....	17
Step 5, Mount the Hood	17
Step 6, Level the Hood.....	17
Step 7, Size and Cut Duct Piece	18
Step 8, Connect Electrical	18
Step 9, Install Duct Covers.....	19
Step 10, Install Filters	19
Step 11, Finalize Installation.....	19

PRODUCT DIMENSIONS AND CLEARANCES

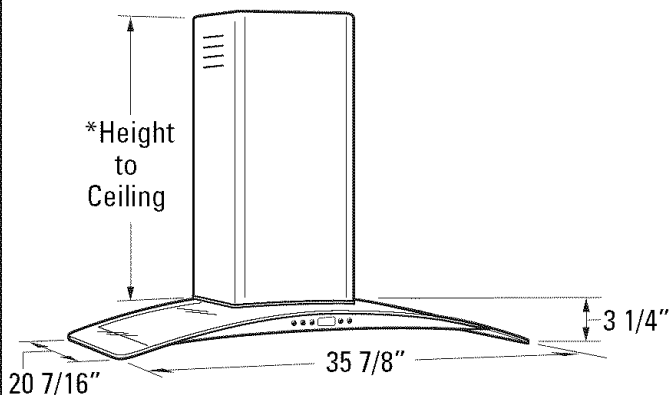

* The Supplied Duct Cover Fits 8' to 9' 5" Ceiling Heights. For 9' 6" to 10' 5" ceilings, order ZX90010.

The vent hood must be installed 24" min., and 30" max. above the cooking surface. The hood installation height above the cooking surface depends upon ceiling height.

The telescopic duct cover conceals the ductwork running from the top of the hood to the ceiling. The supplied duct cover is sized to reach 8' to 9' 5" ceiling heights.

The ZX90010 accessory is available for ceiling heights of 9' 6" to 10' 5".

INSTALLATION OPTIONS

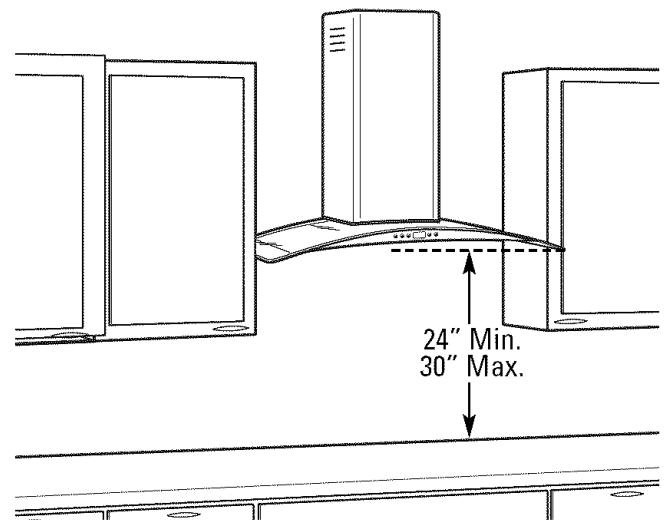

NOTE: Installation height should be measured from the cooking surface to the outer glass sides.

This hood may be installed onto a wall and vented to the outdoors, or it can be installed for recirculating operation. All necessary parts for recirculating operation are supplied with the hood. No kits required.

This hood can be installed over any Monogram electric cooktop or gas cooktop. It cannot be installed over a Monogram Professional cooktop or range.

Installation Preparation

ADVANCE PLANNING

- Determine the exact location of the vent hood.
- Plan the route for venting exhaust to the outdoors.
- Use the shortest and straightest duct route possible. For satisfactory performance, duct run should not exceed 100 ft. equivalent length for any duct configurations.
- Refer to "Duct Fittings" chart to compute the maximum permissible length for duct runs to the outdoors.

CAUTION: To reduce risk of fire and to properly exhaust air, be sure to duct air outside—do not vent exhaust air into spaces within walls or ceilings or into attics, crawl spaces or garages.

PRUDENCE : Il faut prendre soin d'installer un conduit vers l'extérieur pour réduire le risque d'incendie et pouvoir évacuer l'air correctement. Il ne faut pas évacuer l'air correctement. Il ne faut pas évacuer l'air dans l'espace entre les parois d'un mur, un plafond ou un grenier, un espace sanitaire ou un garage.

- Use metal ductwork only. These hoods must use 8" round duct.
- Install a wall cap with damper or roof cap at the exterior opening. Order the wall or roof cap and any transition needed in advance.

Wall Framing for Adequate Support

- This vent hood is heavy. Adequate structural support must be provided in all types of installations. The hood must be secured to vertical studs in the wall, or to a horizontal support.
- The vent hood should be on site before final framing and wall finishing. This will help to accurately locate the duct work and electrical service.
- Installation will be easier if the vent hood is installed before the cooktop and countertop are installed.

Accessory Duct Cover

- This hood is shipped with a decorative duct cover for ceiling heights of 7' 11" to 9' 5". ZX90010 duct cover accessory is available to reach 9' 6" to 10' 5" ceiling heights. The accessory should be ordered with the hood and be on site before installation begins.

POWER SUPPLY

IMPORTANT – (Please read carefully)

WARNING: FOR PERSONAL SAFETY, THIS APPLIANCE MUST BE PROPERLY GROUNDED.

AVERTISSEMENT : POUR DES RAISONS DE SÉCURITÉ, CET APPAREIL DOIT ÊTRE CORRECTEMENT MISE À LA TERRE.

Remove house fuse or open circuit breaker before beginning installation.

Do not use an extension cord or adapter plug with this appliance. Follow National electrical codes or prevailing local codes and ordinances.

Electrical supply

These vent hoods must be supplied with 120V, 60Hz, and connected to an individual, properly grounded branch circuit, and protected by a 15 or 20 amp circuit breaker or time delay fuse.

- Wiring must be 2 wire with ground.
- If the electrical supply does not meet the above requirements, call a licensed electrician before proceeding.
- Route house wiring as close to the installation location as possible, in the ceiling or back wall.
- Connect the hood wiring to the house wiring in accordance with local codes.

Grounding instructions

The grounding conductor must be connected to a grounded metal, permanent wiring system, or an equipment-grounding terminal or lead on the hood.

WARNING: The improper connection of the equipment-grounding conductor can result in a risk of electric shock. Check with a qualified electrician or service representative if you are in doubt whether the appliance is properly grounded.

AVERTISSEMENT : Le mauvais branchement du fil de mise à la terre peut causer un choc électrique. En cas de doute, consulter un électricien qualifié ou un technicien pour déterminer si l'appareil est à la terre.

CAUTION: Automatically Operated Device – To reduce the risk of injury disconnect from power supply before servicing. This unit is equipped with an integral disconnecting switch located inside the blower housing.

PRUDENCE : Appareil commandé automatiquement. Afin de réduire les risques de blessure, débranchez l'appareil de l'alimentation électrique avant de procéder à une réparation. L'appareil est équipé d'un sectionneur intégral situé à l'intérieur du logement du ventilateur.

Installation Preparation

DUCT FITTINGS

Use this chart to compute maximum permissible lengths for duct runs to outdoors.

NOTE: Do not exceed maximum permissible equivalent lengths!

**Maximum duct length:
100 foot for 8" round duct**









Flexible ducting:

If flexible metal ducting is used, all the equivalent feet values in the table should be doubled. The flexible metal duct should be straight and smooth and extended as much as possible.

DO NOT use flexible plastic ducting.

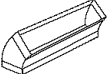
NOTE: Any home ventilation system, such as a ventilation hood, may interrupt the proper flow of combustion air and exhaust required by fireplaces, gas furnaces, gas water heaters and other naturally vented systems. To minimize the chance of interruption of such naturally vented systems, follow the heating equipment manufacturer's guidelines and safety standards such as those published by NFPA and ASHRAE.

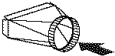
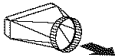
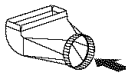
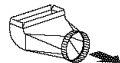
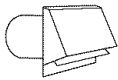
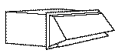
This Hood Must Use an 8" Round Duct.

Duct Piece	Dimensions	Equivalent Length*	Quantity Used	Total Equivalent Length
	Round, straight	1 ft. (per foot length)		
	3-1/4" x 12" 3-1/4" x 24" straight	1 ft. (per foot length)		
	8" round 90° elbow	15 ft.		
	8" round 45° elbow	8 ft.		
	3-1/4" x 12" 90° elbow	11 ft.		
	3-1/4" x 12" or 45° elbow	6 ft.		
	3-1/4" x 12" 90° flat elbow	24 ft.		
	8" round to 3-1/4" x 12" or 3-1/4" x 24" transition	1 ft.		
	3-1/4" x 12" to 8" round transition	8 ft.		
	8" round to 3-1/4" x 12" or transition 90° elbow	16 ft.		
	3-1/4" x 12" to 8" round round transition 90° elbow	17 ft.		
	8" round wall cap with damper	30 ft.		
	3-1/4" x 12" wall cap with damper	30 ft.		
	8" round roof cap	26 ft.		
	8" round roof vent	26 ft.		

*Actual length of straight duct plus duct fitting equivalent. Equivalent length of duct pieces are based on actual tests conducted by GE Evaluation Engineering and reflect requirements for good venting performance with any ventilation hood.

Total Duct Run _____

Installation Preparation

TOOLS AND MATERIALS REQUIRED (NOT SUPPLIED)

- Tape measure
- Knife
- Spirit level
- Wire cutter/stripper
- Wire nuts
- Electric drill with 5/16" and 3/8" bits
- Phillips and flat blade screwdrivers
- Hammer
- Pliers
- Safety glasses
- Duct tape
- Tape to mount template
- Gloves to protect against sharp edges
- 120V 60Hz. 15 or 20 Amp, 2 wire with ground Properly grounded branch circuit
- Strain relief for junction cover
- 8" round metal duct, length to suit installation
- Saw, jig saw or reciprocating saw

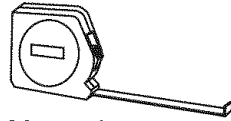

Measuring tape

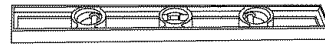

Spirit level



Gloves



Knife

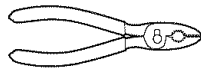

Pliers

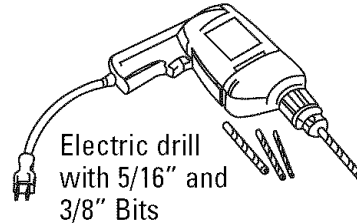

Electric drill
with 5/16" and
3/8" Bits

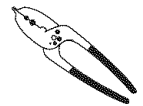

Wire
cutter/stripper



Duct tape



Safety glasses

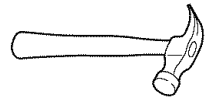

Hammer



Strain relief



12" long
Phillips
head
screwdriver

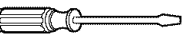

Flat blade
screwdriver



Wire nuts



Masking tape

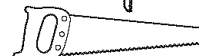

Saw, jig saw or
reciprocating
saw

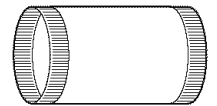

8" round metal duct,
length to suit
installation

REMOVE THE PACKAGING

CAUTION: LIFT THE HOOD OUT OF THE BOX BY THE CENTER METAL PORTION. DO NOT LIFT BY THE GLASS SIDES.

PRUDENCE : LEVEZ LA HOTTE À L'EXTÉRIEUR DE LA BOÎTE PAR LA PORTION MÉTAL CENTRAL. NE LEVEZ PAS PAR LES CÔTÉS DE VERRE.

CAUTION: Wear gloves to protect against sharp edges.

PRUDENCE : Portez des gants pour éviter les blessures causées par les tranchants.

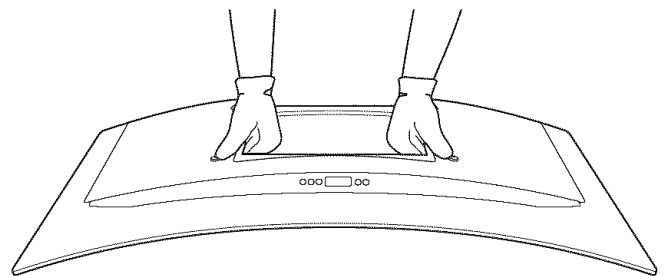

- Grasp the hood by the metal insert in the center and lift straight up and out of the box.
- Remove and properly discard the plastic wrapping.
- Remove parts box, duct covers and other packaging.

Installation Preparation

DETERMINE INSTALLATION HEIGHT

- Telescopic duct covers are provided to conceal the ductwork running to the ceiling.
- This hood can be installed for recirculating operation. No kits required.

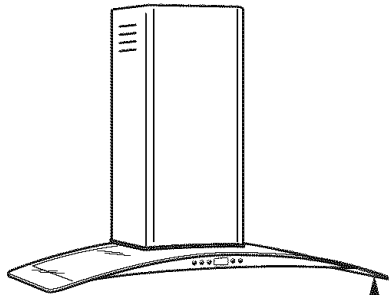

NOTE: Measure installation height from the cooking surface to the outer glass portion of the hood.

24" Min.
30" Max.

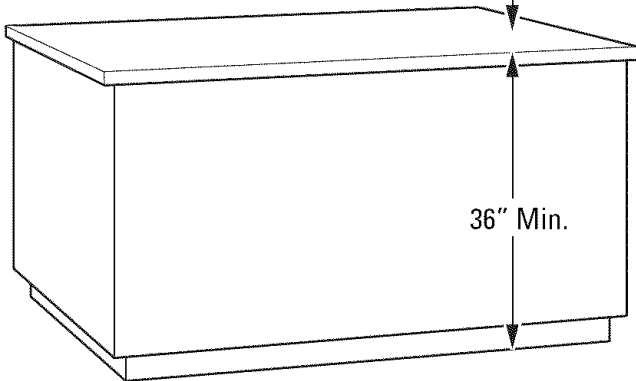

36" Min.

The vent hood must be installed 24" min. and 30" max. above the cooking surface. The hood installation height, from the cooking surface to the bottom of the hood, depends upon ceiling height.

ACCESSORIES:

- Order ZX90010 accessory for ZV900 wall mount hood to reach ceiling heights between 9' 6" and 10' 5". This accessory contains one 40" long duct cover.

Wall Mount ZV900 Installation Heights

Actual Ceiling Height	*Possible VENTED Installation Height	*Possible RECIRCULATING Installation Height	
7' 11"	24" to 26"	24" to 26"	SUPPLIED
8' 0"	24" to 27"	24" to 27"	
8' 1"	24" to 28"	24" to 28"	
8' 2"	24" to 29"	24" to 29"	
8' 3"	24" to 30"	24" to 30"	
8' 4"	24" to 30"	24" to 30"	
8' 5"	24" to 30"	24" to 30"	
8' 6"	24" to 30"	24" to 30"	
8' 7"	24" to 30"	24" to 30"	
8' 8"	24" to 30"	24" to 30"	
8' 9"	24" to 30"	24" to 30"	
8' 10"	24" to 30"	25" to 30"	
8' 11"	24" to 30"	26" to 30"	
9' 0"	25" to 30"	24" to 30"	
9' 1"	26" to 30"	24" to 30"	
9' 2"	27" to 30"	24" to 30"	
9' 3"	28" to 30"	24" to 30"	
9' 4"	29" to 30"	24" to 30"	
9' 5"	30"	25" to 30"	
9' 6"	24" to 30"	24" to 30"	ACCESSORY ZX90010
9' 7"	24" to 30"	24" to 30"	
9' 8"	24" to 30"	24" to 30"	
9' 9"	24" to 30"	24" to 30"	
9' 10"	24" to 30"	24" to 30"	
9' 11"	24" to 30"	24" to 30"	
10'	24" to 30"	24" to 30"	
10' 1"	24" to 30"	24" to 30"	
10' 2"	25" to 30"	24" to 30"	
10' 3"	26" to 30"	25" to 30"	
10' 4"	27" to 30"	26" to 30"	
10' 5"	28" to 30"	27" to 30"	



*Based on 36" countertop height.

Installation Preparation

CHECK INSTALLATION HARDWARE

Locate the hardware accessory box packed with the hood and check contents.

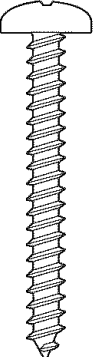
HARDWARE PACKAGE
Locate and count screws



3 wood screws

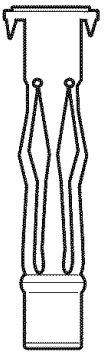

3 wall fasteners

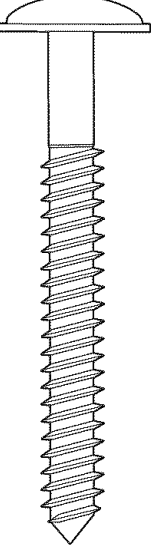

3 wall bracket screws

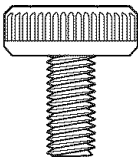

2 thumb screws

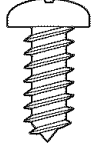

12 hood attachment screws

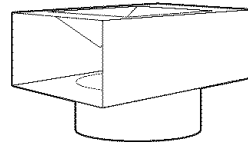

Air deflector for recirculating installation only



Duct bracket

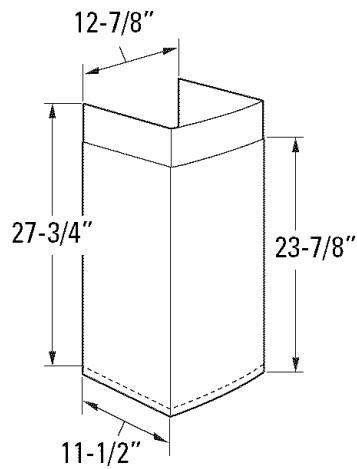

2-piece decorative duct cover (dimension shown for reference only)

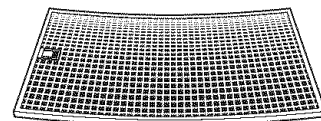

Stainless steel filter

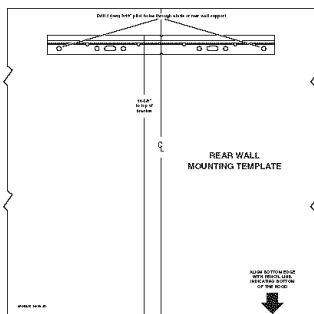

Wall mount template

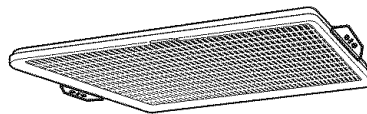

1 charcoal filter for recirculating installation

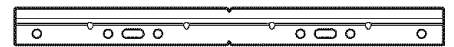

Mounting bracket

Installation Instructions

INSTALLATION—VENTED TO THE OUTSIDE

DUCTWORK, WIRING LOCATIONS

Determine the exact location of the vent hood.

- Locate the template packed with the literature.
 - Measure 36" from the floor to the top of the cooking surface. Add hood installation height determined on page 7. Mark that location.
 - Use a level to draw a straight pencil line on the wall.

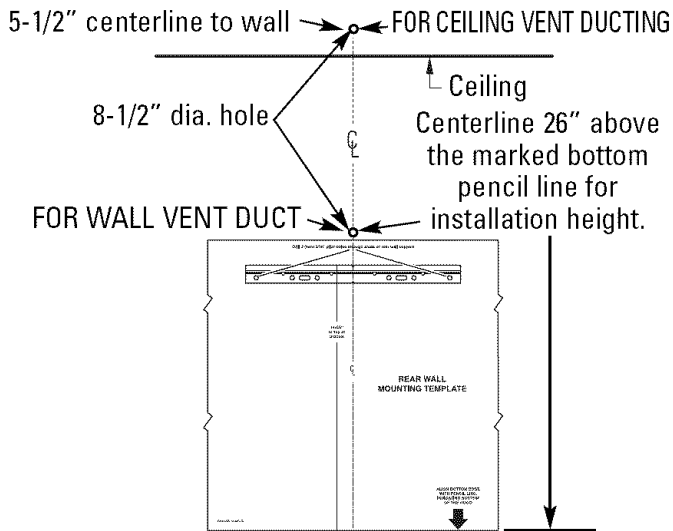

- Tape the template in position along the penciled line. CHECK TO BE SURE THE TEMPLATE IS LEVEL.

Ceiling ducting:

If ductwork will vent straight up to the ceiling:

- Use a level to draw a line straight up, from the centerline on the template to the ceiling.
- Measure 5-1/2" from the back wall to the centerline of an 8-1/2" hole on the ceiling.

NOTE: If drywall is not present, add drywall thickness to the 5-1/2" dimension.

Wall Ducting:

If ductwork will vent to the rear:

- Use a level to draw a line straight up from the centerline on the template.
- Measure at least 26" above the pencil line that indicates the bottom installation height, to the centerline of an 8-1/2" dia. duct hole. (Hole may be elongated for duct elbow.)

HOUSE WIRING LOCATION:

- The junction box is located on the top left side of the hood.
- Wiring should enter the back wall at least 22" above the bottom of the hood, and within 6" of the left side of the centerline.

1 INSTALL FRAMING FOR HOOD SUPPORT

IMPORTANT – Framing must be capable of supporting 100 lbs.

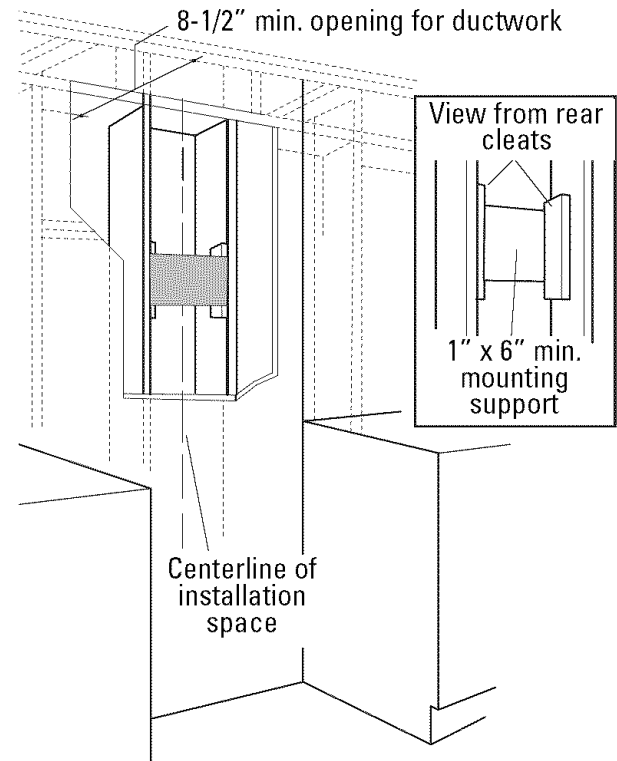

If drywall is present, mark the screw hole locations for the top mounting brackets. Remove the template.

- Cut away enough drywall to expose 2 vertical studs at the bracket location indicated on the template.
- Install a horizontal support at least 1" x 6" between two wall studs at the bottom mounting bracket installation location. **The horizontal support must be flush with the room side of the studs.** Use cleats behind both sides of the support to secure to wall studs.
- Reinstall drywall.

Installation Instructions

INSTALLATION—VENTED TO THE OUTSIDE

2 INSTALL MOUNTING BRACKET

This vent hood must be secured to the horizontal support or wall studs.

- With the template taped in place, use a punch to mark mounting bracket screw locations.
- Drill 3/16" pilot holes in 2 of the punched locations in the lower bracket.
- Remove the template.

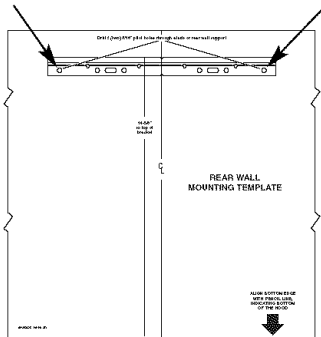

- Use wood screws to secure the mounting bracket to the wall. The screws must engage wall studs or the installed horizontal mounting support.
- Check to be sure that the bracket is level.

3 INSTALL DUCT BRACKET

The duct bracket should be installed against the back wall and flush with the ceiling. This bracket will hold the duct cover in place at the top.

Secure the bracket to the wall:

- Align the marked centerline on the bracket with the centerline on the wall.
- Mark 2 screw hole locations in the wall.
- Drill 3/16" pilot holes in the marked locations.
- If pilot holes do not enter studs, enlarge the holes to 3/8" and install wall fastener anchors.
- Drive screws, by hand, into the fasteners to allow anchors to expand. Remove the screws.
- Secure the bracket to the wall with wood screws and/or fasteners.

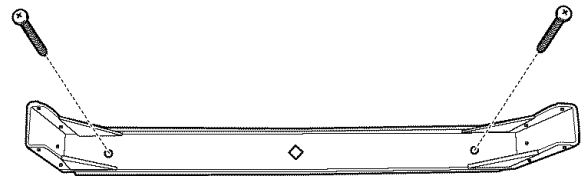

Installation Instructions

INSTALLATION—VENTED TO THE OUTSIDE

4 PREPARE THE HOOD

- Place the hood on a padded surface.
- Position the motor housing at the back of the hood. Electrical connectors should face the front, with rear mounting hooks at the back.
- Slip the bottom flange of the motor housing into the side slots at the top rear opening.

- Carefully lay the hood on its back.
- Fasten the hood to the motor housing from the bottom, using 6 screws.

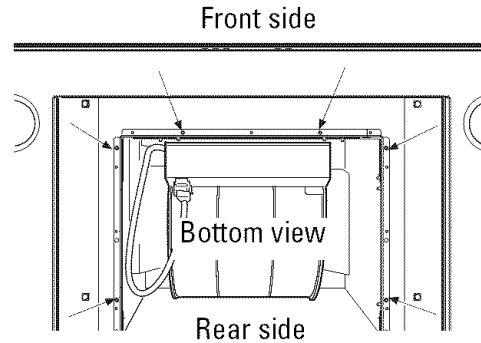
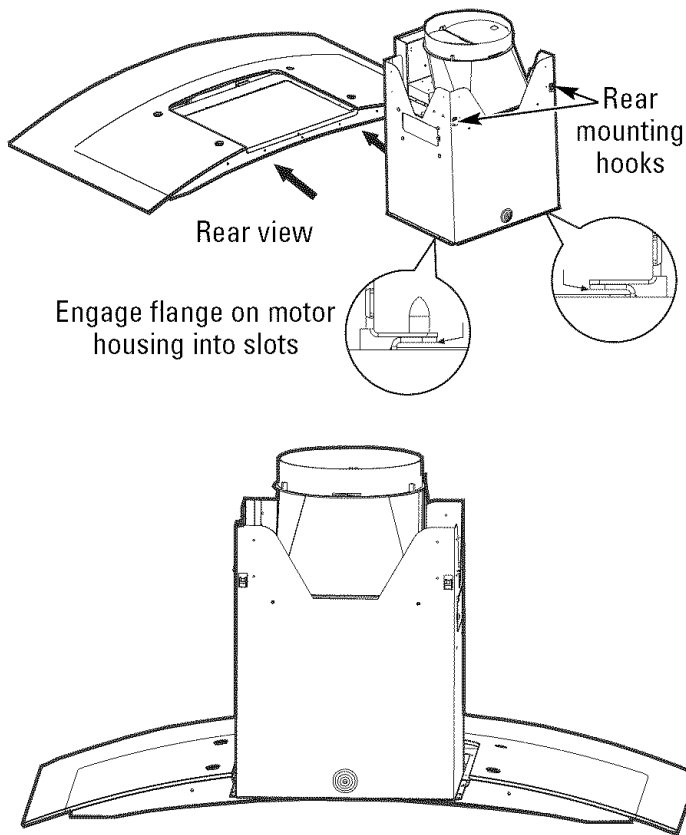

- Join two cable connectors at the front of the hood.

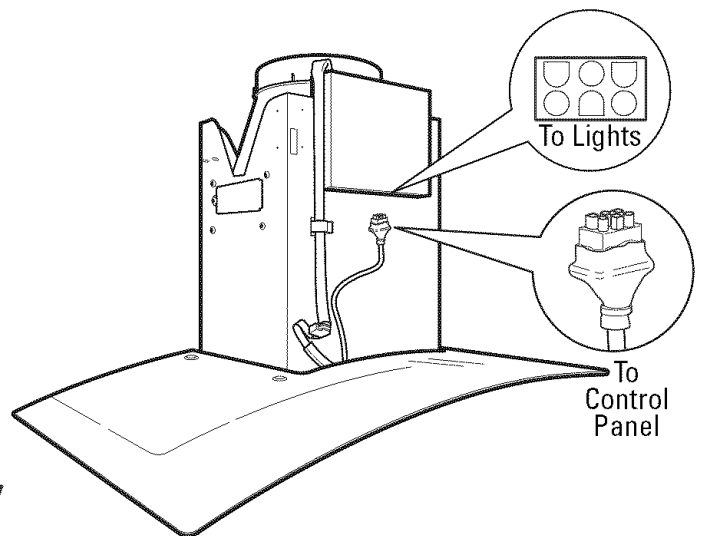

Installation Instructions

INSTALLATION—VENTED TO THE OUTSIDE

5 MOUNT THE HOOD

WARNING: 2 people are required to lift and position the hood onto the mounting bracket.

AVERTISSEMENT :

Il faut deux personnes pour lever et mettre en place la hotte sur le support de montage.

- Lift the hood onto the mounting bracket.
- Position a spirit level at the bottom of the hood to check side to side leveling.

6 LEVEL THE HOOD

This hood has built-in levelers on the mounting hooks at each side. Use a long Phillips screwdriver from the front to access the levelers.

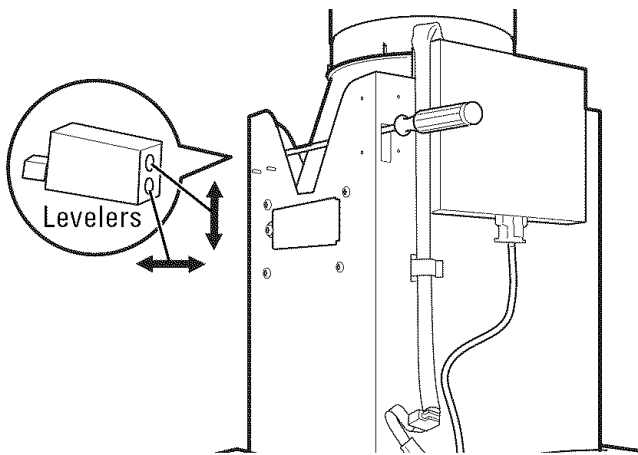

- Use the top screw hole in the leveler to raise or lower the hood on that side.
- Use the bottom screw hole to pull the hood tight against the wall surface.

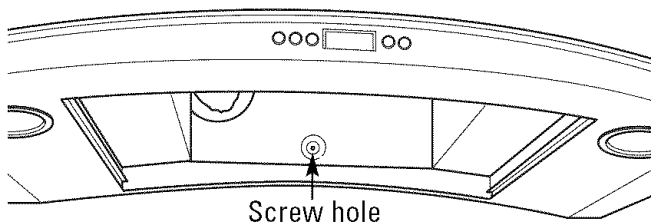

- Mark hole location at the bottom of the hood.
- Remove the hood. If the bottom screw hole does not enter a stud, enlarge the hole to 3/8" and install wall fastener anchors.
- Place the hood back onto the mounting bracket, check level again and install the wall fastener.

7 CONNECT DUCTWORK

- Install ductwork, making connections in the direction of airflow as illustrated.
- Push duct over the exhaust outlet and damper.
- Secure joints in ductwork with sheetmetal screws.
- Wrap all duct joints and the flange connections with duct tape for an airtight seal.

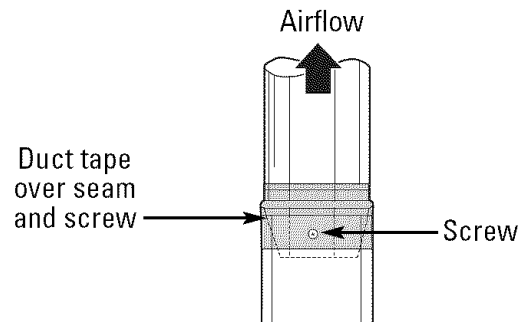

CAUTION: Do not use sheet metal screws at the hood flange connection. Doing so will prevent proper damper operation. Seal connection with tape only.

PRUDENCE :

Il ne faut pas utiliser de vis autotaraudeuses à la connexion du collet de la hotte. Ceci empêcherait le bon fonctionnement du registre. N'utiliser que du ruban adhésif pour assurer l'étanchéité du raccord.

Installation Instructions

INSTALLATION—VENTED TO THE OUTSIDE

8 CONNECT ELECTRICAL

Verify that power is turned off at the source.

WARNING: If house wiring is not 2-wire with a ground wire, a ground must be provided by the installer. When house wiring is aluminum, be sure to use U.L. approved anti-oxidant compound and aluminum-to-copper connectors.

AVERTISSEMENT :

Si la maison n'est pas câblée avec deux fils et un fil de terre, l'installateur doit installer un fil de terre. Quand les fils sont en aluminium, il faut prendre soin d'utiliser des connecteurs aluminium à cuivre avec une pâte antioxydante approuvée par U.L.

- Remove junction box cover and knockout on the left side.

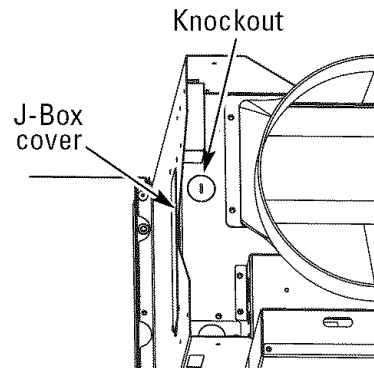

- Secure the house wiring to the junction box with a strain relief.

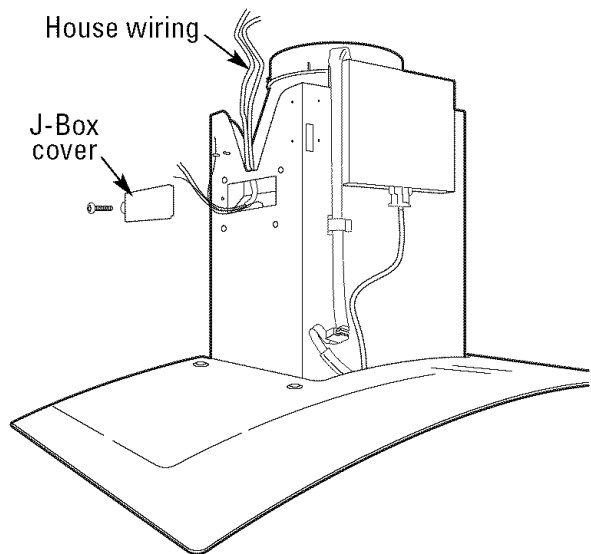

- Connect white leads to branch circuit white lead.
- Connect black leads to branch circuit black lead.
- Connect green/yellow leads to branch circuit green lead or bare ground lead.
- Secure all connections with wire nuts on each electrical connector.
- Push wires into junction box and replace cover. Be sure wires are not pinched.
- Secure J-Box cover with original screw.

Installation Instructions

INSTALLATION—VENTED TO THE OUTSIDE

9 INSTALL DUCT COVERS

- Place the decorative duct covers on top of the hood. Mounting screws

NOTE: The inside (upper) duct piece has holes on one end. The holes are intended for use when the hood is installed for recirculating purposes. Slide the inside end into the outer piece; the vent holes should not be visible in this installation.

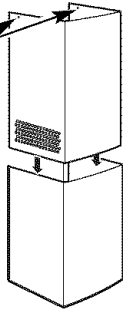

The inside duct piece must slip into the folded ends of the outer section.

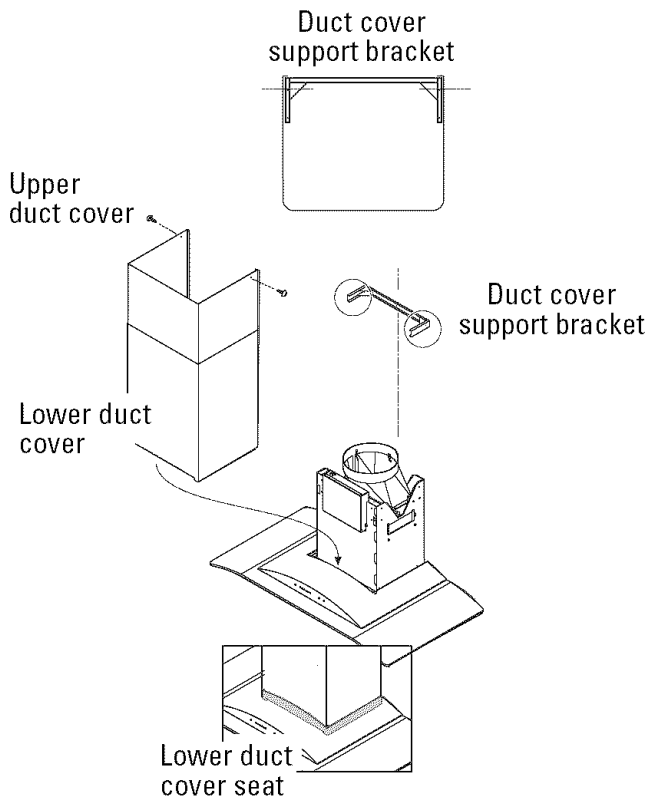

- Extend the inner duct upward to the ceiling bracket.
- Secure duct cover to ceiling bracket with 2 screws.

10 INSTALL FILTERS

IMPORTANT: Check to be sure that the main ON/OFF switch next to the motor is in the ON position.

- Remove protective film on the filters.

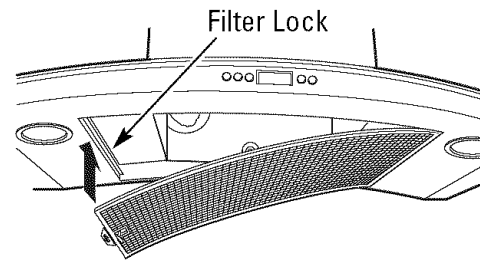

NOTE: The charcoal filter is not required for this installation.

- Tip the filter into the left or right side of the opening. Lift the filter to the opposite side and into the filter lock.
- To remove the filter, pull the filter lock downward.

11 FINALIZE INSTALLATION

- Check to be sure all tape and packaging materials have been removed.
- Refer to the Owner's Manual for operating instructions.

Installation Instructions

INSTALLATION—RECIRCULATING

DUCTWORK, WIRING LOCATIONS

- Determine the exact location of the vent hood.
- Locate the template packed with the literature.
- Measure 36" from the floor to the top of the cooking surface. Add hood installation height determined on page 7. Mark that location.

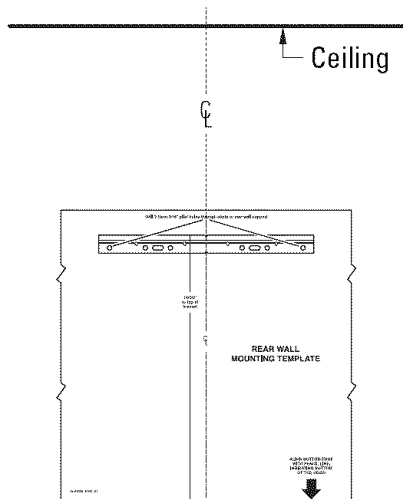

- Tape the template in position along the penciled line. CHECK TO BE SURE THE TEMPLATE IS LEVEL.
- Use a level to draw a line straight up, from the centerline on the template to the ceiling.

HOUSE WIRING LOCATION:

- The junction box is located on the top left side of the hood.
- Wiring should enter the back wall at least 22" above the bottom of the hood, and within 6" of the centerline.

1 INSTALL FRAMING FOR HOOD SUPPORT

IMPORTANT: Framing must be capable of supporting 100 lbs.

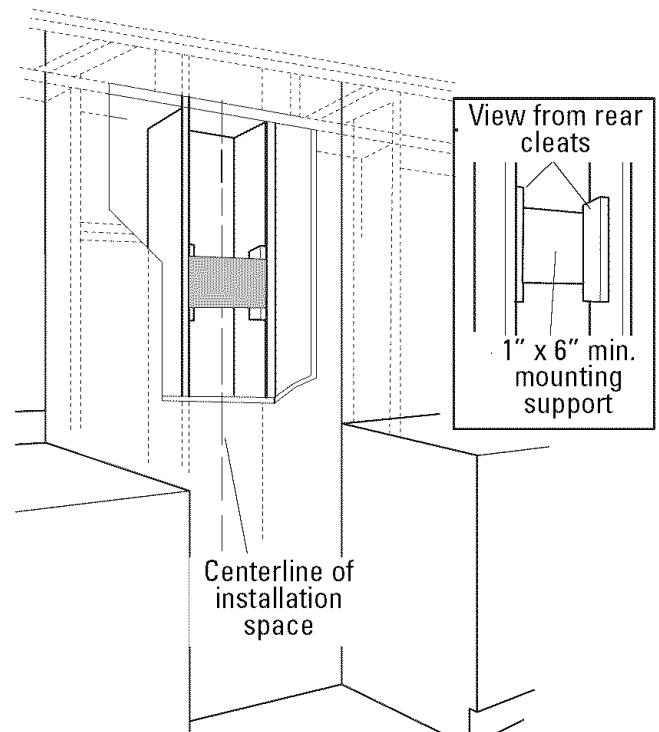

If drywall is present, mark the screw hole locations for the top mounting brackets. Remove the template.

- Cut away enough drywall to expose 2 vertical studs at the bracket location indicated on the template.
- Install a horizontal support at least 1" x 6" between two wall studs at the bottom mounting bracket installation location. **The horizontal support must be flush with the room side of the studs.** Use cleats behind both sides of the support to secure to wall studs.
- Reinstall drywall.

Installation Instructions

INSTALLATION—RECIRCULATING

2 INSTALL MOUNTING BRACKET

This vent hood must be secured to the horizontal support or wall studs.

- With the template taped in place, use a punch to mark mounting bracket screw locations.
- Drill 3/16" pilot holes in 2 of the punched locations in the lower bracket.
- Remove the template.

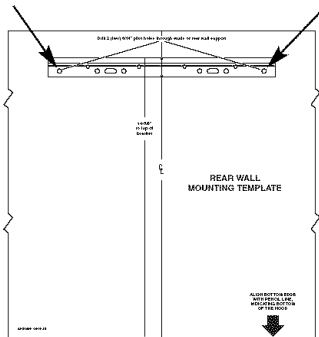

- Use wood screws to secure the mounting bracket to the wall. The screws must engage wall studs or the installed horizontal mounting support.
- Check to be sure that the bracket is level.

3 INSTALL DUCT BRACKET

The duct bracket should be installed against the back wall and flush with the ceiling. This bracket will hold the duct cover in place at the top.

Secure the bracket to the wall:

- Align the marked centerline on the bracket with the centerline on the wall.
- Mark 2 screw hole locations in the wall.
- Drill 3/16" pilot holes in the marked locations.
- If pilot holes do not enter studs, enlarge the holes to 3/8" and install wall fastener anchors.
- Drive screws, by hand, into the fasteners to allow anchors to expand. Remove the screws.
- Secure the bracket to the wall with wood screws and/or fasteners.

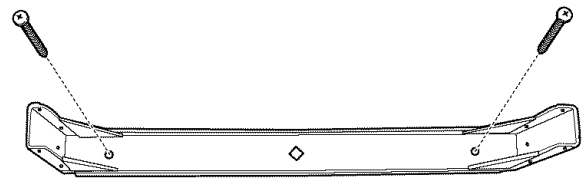

Installation Instructions

INSTALLATION—RECIRCULATING

4 PREPARE THE HOOD

- Place the hood on a padded surface.
- Position the motor housing at the back of the hood. Electrical connectors should face the front, with rear mounting hooks at the back.
- Slip the bottom flange of the motor housing into the side slots at the top rear opening.

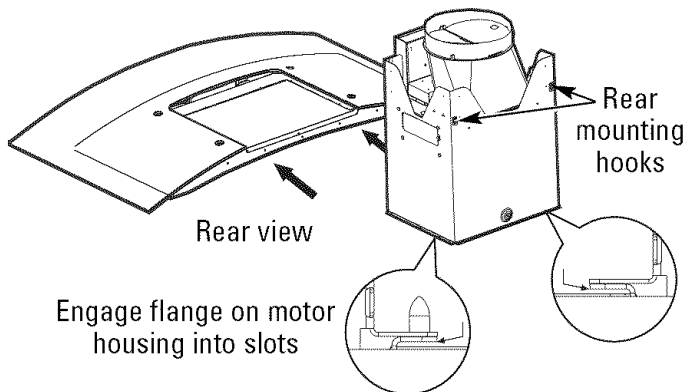

- Carefully lay the hood on its back.
- Fasten the hood to the motor housing from the bottom, using 6 screws.

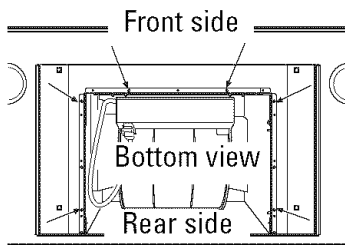

- Join two cable connectors at the front of the hood.

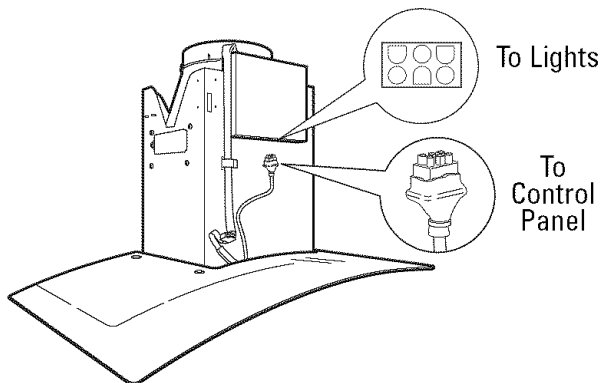

5 MOUNT THE HOOD

WARNING: 2 people are required to lift and position the hood onto the mounting bracket.

AVERTISSEMENT :

If faut deux personnes pour lever et mettre en place la hotte sur le support de montage.

- Lift the hood onto the mounting bracket.
- Position a spirit level at the bottom of the hood to check side to side leveling.

6 LEVEL THE HOOD

This hood has built-in levelers on the mounting hooks at each side. Use a long Phillips screwdriver from the front to access the levelers.

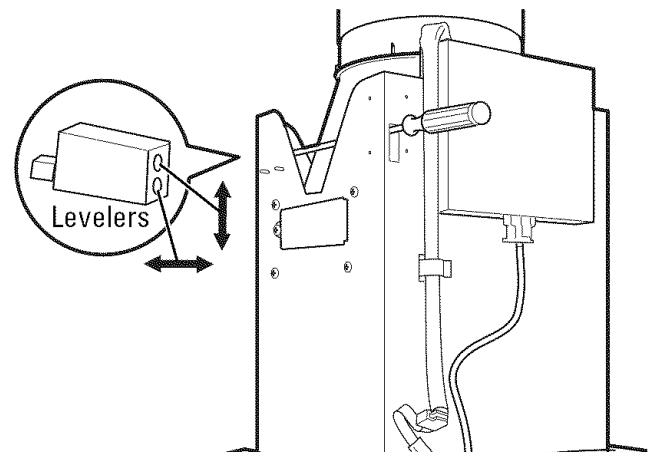

- Use the top screw hole in the leveler to raise or lower the hood on that side.
- Use the bottom screw hole to pull the hood tight against the wall surface.

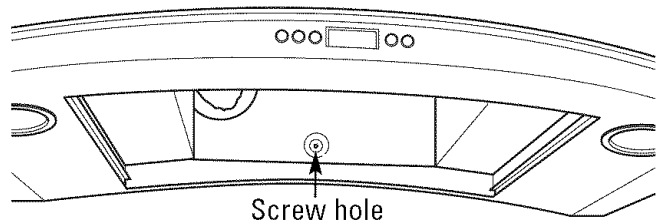

- Mark hole location at the bottom of the hood.
- Remove the hood. If the bottom screw hole does not enter a stud, enlarge the hole to 3/8" and install wall fastener anchors.
- Place the hood back onto the mounting bracket, check level again and install the wall fastener.

Installation Instructions

INSTALLATION—RECIRCULATING

7 SIZE AND CUT DUCT PIECE

- Hold upper air deflector with duct connector against the ceiling.
- Measure from the bottom of the air deflector to the top of the hood as shown. Reduce that dimension by 1" to facilitate installation. The duct will cover and overlap the deflector and the hood outlets.

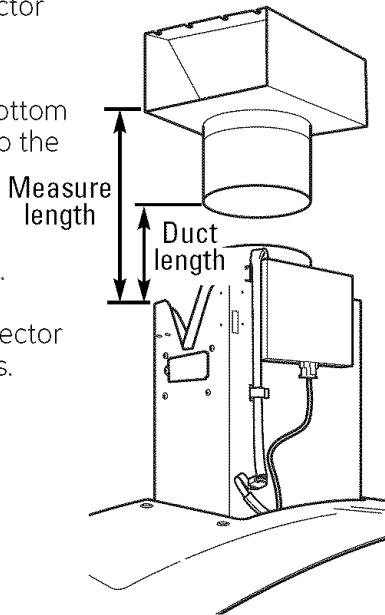

Deflector

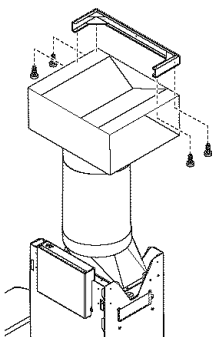

- Cut the duct piece to size and slip onto the bottom of the deflector.
- Place the assembled deflector and duct over the exhaust outlet.
- Hold the assembly against the duct bracket.
- Drive 4 screws into the bottom of the deflector and into the bracket.
- Use duct tape to seal duct to the deflector and at the exhaust outlet.

8 CONNECT ELECTRICAL

Verify that power is turned off at the source.

WARNING: If house wiring is not 2-wire with a ground wire, a ground must be provided by the installer. When house wiring is aluminum, be sure to use U.L. approved anti-oxidant compound and aluminum-to-copper connectors.

AVERTISSEMENT :

Si la maison n'est pas câblée avec deux fils et un fil de terre, l'installateur doit installer un fil de terre. Quand les fils sont en aluminium, il faut prendre soin d'utiliser des connecteurs aluminium à cuivre avec une pâte antioxydante approuvée par U.L.

- Remove junction box cover and knockout on the left side.

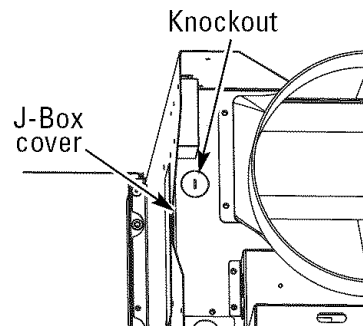

- Secure the house wiring to the junction box with a strain relief.

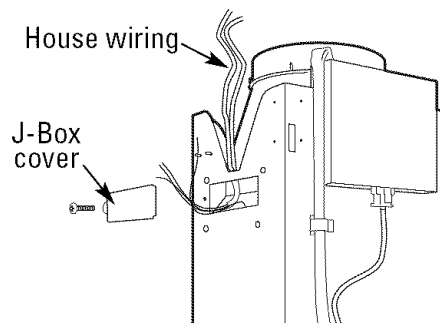

- Connect white leads to branch circuit white lead.
- Connect black leads to branch circuit black lead.
- Connect green/yellow leads to branch circuit green lead or bare ground lead.
- Secure all connections with wire nuts on each electrical connector.
- Push wires into junction box and replace cover. Be sure wires are not pinched.
- Secure J-Box cover with original screw.

Installation Instructions

INSTALLATION—RECIRCULATING

9 INSTALL DUCT COVERS

- Place the decorative duct covers on top of the hood.

NOTE: The inside piece has holes on one end intended for use when the hood is installed for recirculating purposes. Be sure the vented end is at the top; the vent holes will be visible in this installation.

The inside duct piece must slip into the folded ends on the outer section.

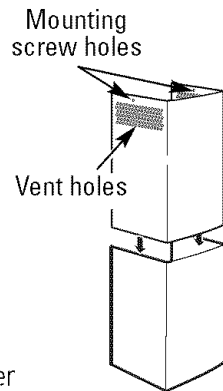

Duct cover support bracket

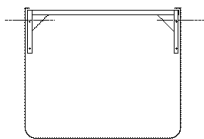

Upper duct cover

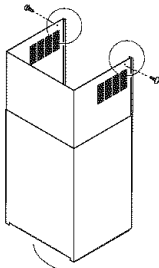

Lower duct cover

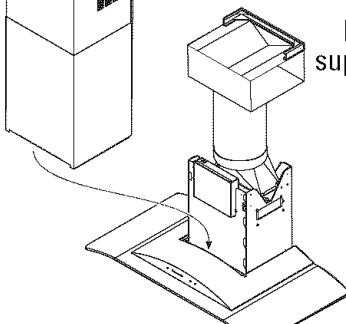

Duct cover support bracket

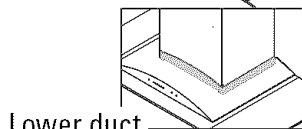

Lower duct cover seat

- Extend the inner duct upward to the ceiling bracket.
- Secure duct cover to ceiling bracket with 2 screws.

10 INSTALL FILTERS

IMPORTANT: Check to be sure that the main ON/OFF switch next to the motor is in the ON position.

Charcoal filter

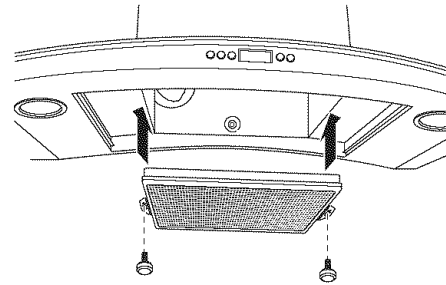

- Install the black charcoal filter into the center opening. Secure the filter with thumbscrews on each side.

Metal filter

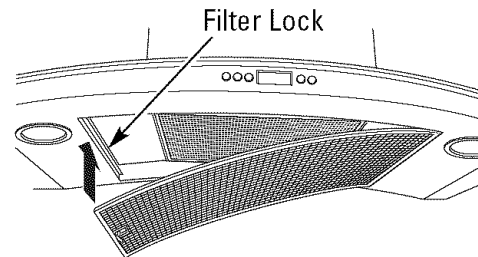

- Tip the filter into the left or right side of the opening. Lift the filter to the opposite side and into the filter lock.
- To remove the filter, pull the filter lock downward.

11 FINALIZE INSTALLATION

- Remove all tape and packing material.
- Refer to the Owner's Manual for operating instructions.

NOTE: While performing installations described in this book, safety glasses or goggles should be worn.

For Monogram® local service in your area, call 1.800.444.1845.

NOTE: Product improvement is a continuing endeavor at General Electric. Therefore, materials, appearance and specifications are subject to change without notice.



Monogram.®

*GE Consumer & Industrial
GE Appliances
General Electric Company
Louisville, KY 40225
ge.com*

©2006 GE Company