

Operator's Manual

CRAFTSMAN®

PROFESSIONAL

356 mm (14 in.) ABRASIVE CUT-OFF MACHINE

Model No.
315.212900

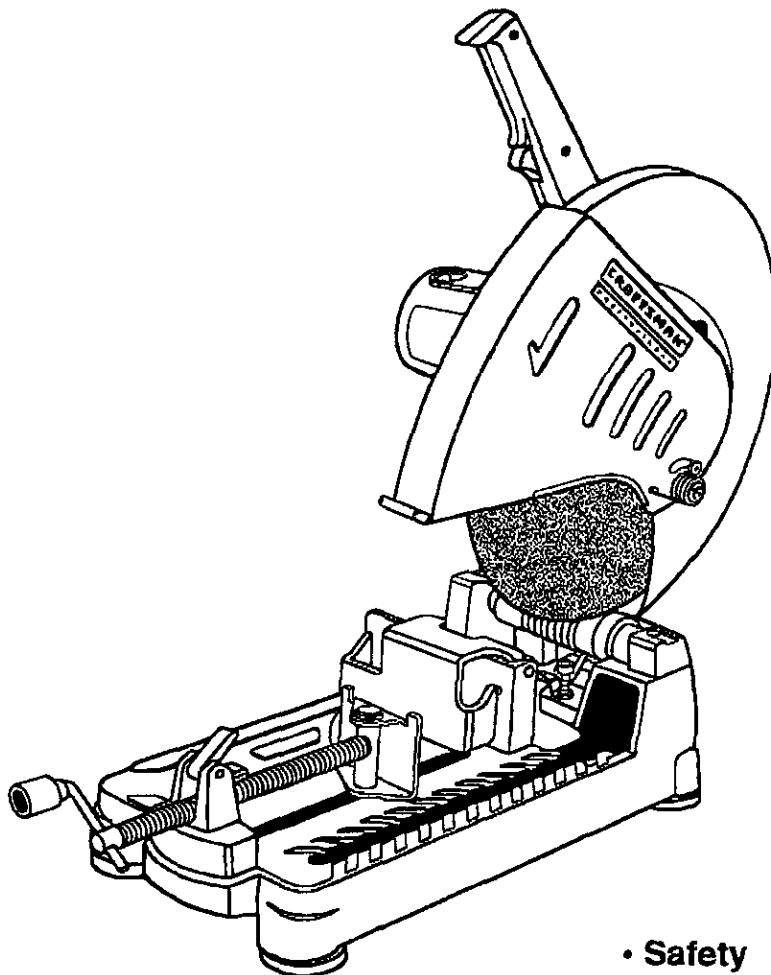

Save this manual for
future reference.

⚠ CAUTION: Read and follow
all Safety Rules and Operating
Instructions before first use of
this product.

Customer Help Line: 1-800-932-3188

Sears, Roebuck and Co., 3333 Beverly Rd., Hoffman Estates, IL 60179 USA
Visit the Craftsman web page: www.sears.com/craftsman

983000-037
4-02

- Safety
- Features
- Adjustments
- Operation
- Maintenance
- Parts List



TABLE OF CONTENTS

■ Table of Contents	2
■ Warranty and Introduction	2
■ Rules for Safe Operation	3-5
■ Electrical	6
■ Unpacking, Loose Parts, and Product Specifications	7
■ Features	8-9
■ Adjustments	10-13
■ Operation	13-16
■ Maintenance	16-17
■ Troubleshooting	17-18
■ Exploded Views and Repair Parts Lists	20-25
■ Parts Ordering / Service	26

WARRANTY

FULL ONE YEAR WARRANTY

If this product fails due to a defect in material or workmanship within one year from the date of purchase, Sears will repair it free of charge.

Contact a Sears Service Center for repair.

If this product is used for commercial or rental purposes, this warranty applies only for 90 days from the date of purchase.

This warranty gives you specific legal rights, and you may also have other rights which vary from state to state.

Sears, Roebuck and Co., Dept. 817WA, Hoffman Estates, IL 60179

INTRODUCTION

Your saw has many features for making cutting operations more pleasant and enjoyable. Safety, performance and dependability have been given top priority in the design of this saw making it easy to maintain and operate.

⚠ CAUTION: Carefully read through this entire operator's manual before using your new saw. Pay close attention to the Rules For Safe Operation, and all Safety Alert Symbols including Danger, Warning and Caution. If you use your saw properly and only for what it is intended, you will enjoy years of safe, reliable service.

⚠ Look for this symbol to point out important safety precautions. It means attention!!! Your safety is involved.

⚠ WARNING:



The operation of any power tool can result in foreign objects being thrown into your eyes, which can result in severe eye damage. Before beginning tool operation, always wear safety goggles or safety glasses with side shields and a full face shield when needed. We recommend Wide Vision Safety Mask for use over eyeglasses or standard safety glasses with side shields. Always wear eye protection which is marked to comply with ANSI Z87.1.

RULES FOR SAFE OPERATION

The purpose of safety symbols is to attract your attention to possible dangers. The safety symbols, and the explanations with them, deserve your careful attention and understanding. The safety warnings do not by themselves eliminate any danger. The instructions or warnings they give are not substitutes for proper accident prevention measures.

SYMBOL MEANING



SAFETY ALERT SYMBOL:

Indicates danger, warning or caution. May be used in conjunction with other symbols or pictographs.



DANGER: Failure to obey a safety warning will result in serious injury to yourself or to others. Always follow the safety precautions to reduce the risk of fire, electric shock and personal injury.



WARNING: Failure to obey a safety warning can result in serious injury to yourself or to others. Always follow the safety precautions to reduce the risk of fire, electric shock and personal injury.



CAUTION: Failure to obey a safety warning may result in property damage or personal injury to yourself or to others. Always follow the safety precautions to reduce the risk of fire, electric shock and personal injury.

Note: Advises you of information or instructions vital to the operation or maintenance of the equipment.



WARNING: Do not attempt to operate this tool until you have read thoroughly and understand completely all instructions, safety rules, etc. contained in this manual. Failure to comply can result in accidents involving fire, electrical shock, or serious personal injury. Save operator's manual and review frequently for continuing safe operation, and instructing others who may use this tool.

IMPORTANT

Servicing requires extreme care and knowledge of the system and should be performed only by a qualified service technician. For service we suggest you return the tool to your nearest Sears store or repair center for repair. Always use original factory replacement parts when servicing.

READ ALL INSTRUCTIONS

- **KNOW YOUR POWER TOOL.** Read the operator's manual carefully. Learn the saw's applications and limitations as well as the specific potential hazards related to this tool.
- **GUARD AGAINST ELECTRICAL SHOCK** by preventing body contact with grounded surfaces such as pipes, radiators, ranges, refrigerator enclosures.
- **KEEP GUARDS IN PLACE** and in good working order.
- **REMOVE WRENCHES AND ADJUSTING KEYS.** Get in the habit of checking - before turning on tool - that hex keys and adjusting wrenches are removed from tool.
- **KEEP THE WORK AREA CLEAN.** Cluttered work areas and work benches invite accidents. **DO NOT** leave tools or pieces of wood on the saw while it is in operation.

- **DO NOT USE IN DANGEROUS ENVIRONMENTS.** Do not use power tools near gasoline or other flammable liquids, in damp or wet locations, or expose them to rain. Keep the work area well lit.
- **KEEP CHILDREN AND VISITORS AWAY.** All visitors should wear safety glasses and be kept a safe distance from work area. Do not let visitors contact tool or extension cord while operating.
- **MAKE WORKSHOP CHILDPROOF** with padlocks and master switches or by removing starter keys.
- **DO NOT FORCE THE TOOL** it will do the job better and more safely at the rate for which it was designed.
- **USE THE RIGHT TOOL FOR THE JOB.** Do not force the tool or attachment to do a job it was not designed for. Use it only the way it was intended.
- **USE THE PROPER EXTENSION CORD.** Make sure your extension cord is in good condition. Use only a cord heavy enough to carry the current your product will draw. An undersized cord will cause a drop in line voltage resulting in loss of power and overheating. A wire gage size (A.W.G.) of at least 14 is recommended for an extension cord 25 feet

RULES FOR SAFE OPERATION

or less in length. If in doubt, use the next heavier gage. The smaller the gage number, the heavier the cord.

- **INSPECT EXTENSION CORDS PERIODICALLY** and replace if damaged.
- **DRESS PROPERLY.** Do not wear loose clothing, neckties, rings, bracelets, or other jewelry. They can get caught and draw you into moving parts. Rubber gloves and nonslip footwear are recommended when working outdoors. Also wear protective hair covering to contain long hair.
- **ALWAYS WEAR SAFETY GLASSES WITH SIDE SHIELDS.** Everyday eyeglasses have only impact-resistant lenses; they are **NOT** safety glasses.
- **PROTECT YOUR LUNGS.** Wear a face or dust mask if the cutting operation is dusty.
- **PROTECT YOUR HEARING.** Wear hearing protection during extended periods of operation.
- **SECURE WORK.** Use clamps or a vise to hold work when practical. It's safer than using your hand and it frees both hands to operate tool.
- **DO NOT ABUSE CORD.** Never yank cord to disconnect it from receptacle. Keep cord from heat, oil, and sharp edges.
- **DO NOT OVERREACH.** Keep proper footing and balance at all times.
- **MAINTAIN TOOLS WITH CARE.** Keep tools sharp and clean for better and safer performance. Follow instructions for lubricating and changing accessories.
- **DISCONNECT ALL TOOLS.** When not in use, before servicing, or when changing attachments, wheels, bits, cutters, etc., all tools should be disconnected.
- **AVOID ACCIDENTAL STARTING.** Be sure switch is off when plugging in.
- **USE RECOMMENDED ACCESSORIES.** The use of improper accessories may cause risk of injury. Consult operator's manual for recommended accessories.
- **NEVER STAND ON TOOL.** Serious injury could occur if the tool is tipped or if the wheel is unintentionally contacted.
- **CHECK DAMAGED PARTS.** Before further use of the tool, a guard or other part that is damaged should be carefully checked to determine that it will operate properly and perform its intended function. Check for alignment of moving parts, binding of moving parts, breakage of parts, mounting and any other conditions that may affect its operation. A guard or other part that is damaged must be properly repaired or replaced by an authorized service center to avoid risk of personal injury.
- **NEVER LEAVE TOOL RUNNING UNATTENDED. TURN THE POWER OFF.** Do not leave tool until it comes to a complete stop.
- **USE ONLY CORRECT WHEELS.** Do not use wheels with incorrect size holes. Never use wheel washers or wheel screws that are defective or incorrect. The maximum wheel capacity of your cut-off machine is 14 in. (356 mm).
- **DO NOT REMOVE THE MACHINE'S WHEEL GUARDS.** Never operate the machine with any guard or cover removed. Make sure all guards are operating properly before each use.
- **KEEP HANDS AWAY FROM CUTTING AREA.** Keep hands away from wheel. Do not reach underneath work or around or under the wheel while the wheel is rotating. Do not attempt to remove cut material while wheel is moving.
- **WHEEL COASTS AFTER TURN OFF.**
- **NEVER USE IN AN EXPLOSIVE ATMOSPHERE.** Normal sparking of the motor or sparking from cutting metal could ignite fumes.
- **INSPECT TOOL CORDS PERIODICALLY** and if damaged, have repaired at your nearest Sears Authorized Service Center. Stay constantly aware of cord location and keep it well away from the rotating wheel.
- **USE OUTDOOR EXTENSION CORDS.** When tool is used outdoors, use only extension cords with approved ground connection that are intended for use outdoors and so marked.
- **DO NOT USE TOOL IF SWITCH DOES NOT TURN IT ON AND OFF.** Have defective switches replaced by an authorized service center.
- **KEEP TOOL DRY, CLEAN, AND FREE FROM OIL AND GREASE.** Always use a clean cloth when cleaning. Never use brake fluids, gasoline, petroleum-based products, or any solvents to clean tool.
- **ALWAYS SUPPORT LONG WORKPIECES.** To minimize risk of tipping machine, always support long workpieces.
- **BEFORE MAKING A CUT, BE SURE ALL ADJUSTMENTS ARE SECURE.**
- **ALWAYS USE THE VISE CLAMP** to secure the workpiece.
- **NEVER TOUCH WHEEL** or other moving parts during use.
- **NEVER START THE CUT-OFF MACHINE WHEN THE WHEEL IS IN CONTACT WITH THE WORKPIECE.**
- **NEVER** cut more than one workpiece at a time. **DO NOT STACK** more than one workpiece on the machine base at a time.
- **NEVER PERFORM ANY OPERATION "FREE-HAND".** Always secure the workpiece to be cut in the vise.

RULES FOR SAFE OPERATION

- **NEVER** hand hold a workpiece. Workpiece will become very hot while being cut.
 - **NEVER** reach behind, under, or within three inches of the wheel and its cutting path with your hands and fingers for any reason.
 - **NEVER** reach to pick up a workpiece, a piece of scrap, or anything else that is in or near the cutting path of the wheel.
 - **AVOID AWKWARD OPERATIONS AND HAND POSITIONS** where a sudden slip could cause your hand to move into the wheel. **ALWAYS** make sure you have good balance.
 - **NEVER** stand or have any part of your body in line with the path of the wheel.
 - **ALWAYS** release the power switch and allow the wheel to stop rotating before raising it out of the workpiece.
 - **DO NOT TURN THE MOTOR SWITCH ON AND OFF RAPIDLY.** This could cause the wheel to loosen and could create a hazard. Should this ever occur, stand clear and allow the wheel to come to a complete stop. Disconnect your cut-off machine from the power supply and securely retighten the wheel arbor bolt.
 - **REPLACEMENT PARTS.** All repairs, whether electrical or mechanical, should be made at a Sears Authorized Service Center.
 - **WHEN SERVICING** use only identical Sears replacement parts. Use of any other parts may create a hazard or cause product damage.
 - **NEVER** leave the cut-off machine unattended while connected to a power source.
 - **IF ANY PART OF THIS CUT-OFF MACHINE IS MISSING** or should break, bend, or fail in any way, or should any electrical component fail to perform properly, shut off the power switch, remove the machine plug from the power source and have damaged, missing, or failed parts replaced before resuming operation.
 - **MAKE SURE THE CUT-OFF WHEEL IS SECURELY MOUNTED** as described in the operating instructions before connecting the tool to a power supply. Do not tighten wheel excessively, since this can cause cracks.
 - **CHECK THE WHEEL FOR FISSURES AND CRACKS,** and test for normal operation prior to use.
 - **ALWAYS EASE THE ABRASIVE WHEEL AGAINST THE WORK PIECE** when starting to cut. A harsh impact can break the wheel.
 - **ONLY USE A CUT-OFF WHEEL RATED FOR 3300 RPM OR GREATER** and manufactured in compliance with ANSI B 7.1. Always store wheels in a dry place with little temperature variation.
 - **BEFORE CUTTING,** press the trigger switch and allow the cut-off wheel to reach full speed before cutting.
 - **MAKE SURE THE WORK AREA HAS AMPLE LIGHTING** to see the work and that no obstructions will interfere with safe operation **BEFORE** performing any work using your cut-off machine.
 - **DO NOT OPERATE THIS TOOL WHILE UNDER THE INFLUENCE OF DRUGS, ALCOHOL, OR ANY MEDICATION.**
 - **ALWAYS STAY ALERT!** Do not allow familiarity (gained from frequent use of your cut-off machine) to cause a careless mistake. **ALWAYS REMEMBER** that a careless fraction of a second is sufficient to inflict severe injury.
 - **STAY ALERT AND EXERCISE CONTROL.** Watch what you are doing and use common sense. **Do not operate tool when you are tired. Do not rush.**
 - **SAVE THESE INSTRUCTIONS.** Refer to them frequently and use them to instruct other users. If you loan someone this tool, loan them these instructions also.
- ⚠ WARNING:** Some dust created by power sanding, sawing, grinding, drilling, and other construction activities contains chemicals known to cause cancer, birth defects or other reproductive harm. Some examples of these chemicals are:
- lead from lead-based paints,
 - crystalline silica from bricks and cement and other masonry products, and
 - arsenic and chromium from chemically-treated lumber.
- Your risk from these exposures varies, depending on how often you do this type of work. To reduce your exposure to these chemicals, work in a well ventilated area and work with approved safety equipment, such as those dust masks that are specially designed to filter out microscopic particles.



SAVE THESE INSTRUCTIONS

ELECTRICAL

EXTENSION CORDS

Use only 3-wire extension cords that have 3-prong grounding plugs and 3-pole receptacles that accept the tool's plug. When using a power tool at a considerable distance from the power source, use an extension cord heavy enough to carry the current that the tool will draw. An undersized extension cord will cause a drop in line voltage, resulting in a loss of power and causing the motor to overheat. Use the chart provided below to determine the minimum wire size required in an extension cord. Only round jacketed cords listed by Underwriter's Laboratories (UL) should be used.

Length of Extension Cord	Wire Size (A.W.G.)
Up to 25 feet	14
26-50 feet	12

When working with the tool outdoors, use an extension cord that is designed for outside use. This is indicated by the letters **WA** on the cord's jacket.

Before using an extension cord, inspect it for loose or exposed wires and cut or worn insulation.

⚠ CAUTION: Keep the cord away from the cutting area and position the cord so that it will not be caught on material, tools, or other objects during cutting.

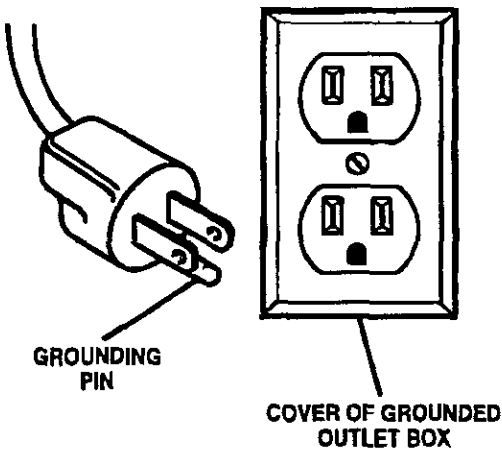

Fig. 1

ELECTRICAL CONNECTION

Your Sears Abrasive Wheel Cut-off Machine is powered by a precision built electric motor. It should be connected to a power supply that is 120 volts, 60 Hz. If the machine does not operate when plugged into an outlet, double check the power supply.

GROUNDING INSTRUCTIONS

In the event of a malfunction or breakdown, grounding provides a path of least resistance for electric current to reduce the risk of electric shock. This tool is equipped with an electric cord having an equipment-grounding conductor and a grounding plug. The plug must be plugged into a matching outlet that is properly installed and grounded in accordance with all local codes and ordinances.

Do not modify the plug provided. If it will not fit the outlet, have the proper outlet installed by a qualified electrician. Improper connection of the equipment-grounding conductor can result in a risk of electric shock. The conductor with insulation having an outer surface that is green with or without yellow stripes is the equipment-grounding conductor. If repair or replacement of the electric cord or plug is necessary, do not connect the equipment-grounding conductor to a live terminal.

Check with a qualified electrician or service personnel if the grounding instructions are not completely understood, or if in doubt as to whether the tool is properly grounded.

Repair or replace a damaged or worn cord immediately.

This tool is intended for use on a circuit that has an outlet like the one shown in *Figure 1*. It also has a grounding pin like the one shown.

UNPACKING AND LOOSE PARTS

Your abrasive cut-off machine has been shipped completely assembled.

- Remove all loose parts from the carton.
- Remove the packing materials from around your machine.
- Carefully lift the cut-off machine from the carton and place it on a level work surface. This is a heavy tool. To avoid back injury, get help when needed.
- Do not discard the packing materials until you have carefully inspected the machine, identified all loose parts, and satisfactorily operated your new abrasive cut-off machine.
- Your cut-off machine has been shipped with the machine arm locked in the down position. To release the arm, push down on top of the machine arm and pull the arm lock lever. *See Figure 3.*
- Hand pressure should remain on the machine arm to prevent sudden rise upon release of the arm lock lever.
- Examine all parts to make sure no breakage or damage has occurred during shipping.

If any parts are damaged or missing, do not attempt to plug in the power cord and turn the switch on until the damaged or missing parts are obtained and are installed correctly.

⚠ WARNING: If any parts are missing do not operate your cut-off machine until the missing parts are replaced. Failure to do so could result in possible serious injury.

LOOSE PARTS LIST

The following items are included with your Abrasive Cut-off Machine:

- 14 in. (356 mm) – Abrasive Wheel – Installed on Machine
- Wheel Wrench – 8 mm Hex Key – Stored on Machine
- Operator's Manual

PRODUCT SPECIFICATIONS

Wheel Type	Reinforced Abrasive Wheels	Fence Angle	
Wheel Diameter	14 in. (356 mm)	Right	45°
Wheel Thickness	1/8 in. (3.2 mm)	Left	0°
Wheel Arbor Hole	1.0 in. (25.4 mm)	Vise Clamp Angle	
Overall Wheel Size	14 in. x 1/8 in. x 1 in. 356 mm x 3.2 mm x 25.4 mm	Right or Left	45°
No Load Speed	3300 RPM	Maximum Cutting Capacities:	
Rating	120 Volts, AC/DC	Round Pipe	5 in. (127 mm) outside diameter
Input	15 Amp	Angle Stock	6-1/2 in. wide x 3-5/16 in. tall 165 mm wide x 84 mm tall
Net Weight	65 lbs. (30 kg.)	Flat Metal Stock	8-1/16 in. wide x 2-5/16 in. tall 205 mm wide x 59 mm tall

⚠ WARNING: This cut-off machine has been designed for cutting metals, using reinforced abrasive cut-off wheels only. Do not remove the wheel, install a steel blade, and attempt to cut other types of materials such as wood, masonry, etc. Attempting to cut these other types of materials could cause an accident resulting in possible serious personal injury.

⚠ WARNING: Do not attempt to modify this tool or create accessories not recommended for use with this tool. Any such alteration or modification is misuse and could result in a hazardous condition leading to possible serious personal injury.

FEATURES

KNOW YOUR ABRASIVE CUT-OFF MACHINE

See Figures 2 and 3.

Before attempting to use your machine, familiarize yourself with all operating features and safety requirements.

⚠ WARNING: Do not allow familiarity with your machine to make you careless. Remember that a careless fraction of a second is sufficient to inflict severe injury.

MOTOR

See Figure 2.

This machine has a strong motor with sufficient power to handle tough cutting jobs. It also has externally accessible brushes for ease of servicing.

14 in. (356 mm) ABRASIVE WHEEL

See Figure 2.

A 14 in. (356 mm) abrasive wheel is included with your cut-off machine. It will cut materials up to 5 in. (127 mm) thick or 8 in. (203 mm) wide, depending upon the thickness or width of the material and the setting at which the cut is being made.

SELF-RETRACTING LOWER WHEEL GUARD

See Figure 2.

The lower wheel guard provides protection from each

side of the wheel. It retracts over the upper wheel guard as the wheel is lowered into the workpiece.

WISE CLAMP

See Figure 2.

A vise clamp has been provided with your cut-off machine. It is located on the end of the vise screw and provides greater control by clamping the workpiece to the fence. It also prevents the workpiece from creeping toward the wheel during a cutting operation.

ADJUSTABLE FLIP FENCE ASSEMBLY

See Figure 2.

The fence on your cut-off machine has been provided to support the workpiece and provide clamping support to the vise for holding your workpiece securely when making all cuts. It is an adjustable flip fence assembly that has been provided to make your cut-off machine more versatile. It adjusts 45° to the right for making angled cuts. It has an extension block that flips down when making cuts in tall or thick stock, such as square stock or tube stock. The extension fence flips up out of the way when making cuts in stock that is thin or wide, such as angle stock.

QUICK LOCK-RELEASE LEVER

See Figure 2.

A quick lock-release lever has been provided on your cut-off machine. This feature allows you to open and close the vise clamp quickly without repetitive turning of the vise crank handle.

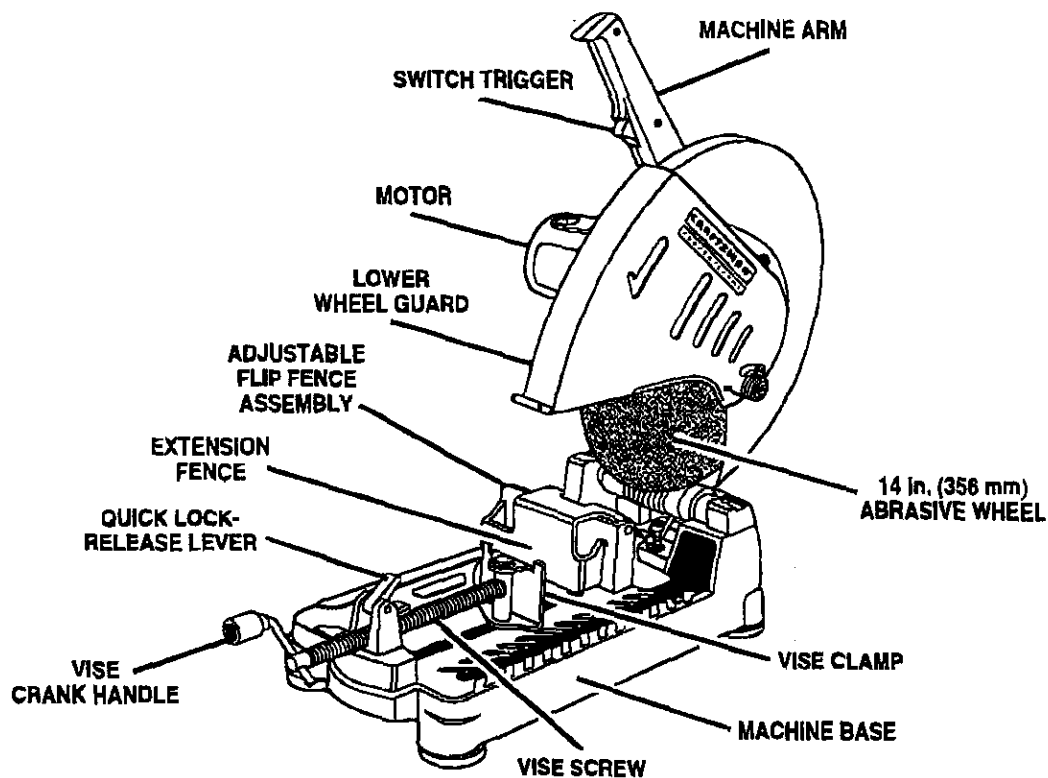

Fig. 2

FEATURES

CARRYING HANDLE

See Figure 3.

For convenience when carrying or transporting your cut-off machine from one place to another, a carrying handle has been provided on top of the machine arm as shown figure 3. To transport, turn off and unplug your machine, then lower machine arm and lock it in the down position. Lock machine arm by pushing in arm lock lever.

LOCK-ON BUTTON

See Figure 3.

Your cut-off machine is equipped with a lock-on feature, which is convenient when continuous cutting for extended periods of time is required. To engage the lock-on feature, depress switch trigger, push in and hold the lock-on button located on the side of the handle, then release switch trigger. Release lock-on button and machine will continue running.

To release lock-on feature, depress switch trigger and release.

If you have the lock-on feature engaged during use and your machine becomes disconnected from power supply, disengage the lock-on feature immediately.

SPINDLE LOCK BUTTON

A spindle lock button has been provided for locking the spindle which keeps the wheel in your machine from rotating. Depress and hold the spindle lock button while installing, changing, or removing wheel only.

TRIGGER LOCK

See Figure 4.

To prevent unauthorized use of your cut-off machine, we suggest that you disconnect it from the power supply and lock the switch in the off position. To lock the switch, install a padlock (not included) through the hole in the switch trigger. A lock with a shackle up to 9/32 in. diameter may be used. When the lock is installed and locked, the switch is inoperable. Store the padlock key in another location.

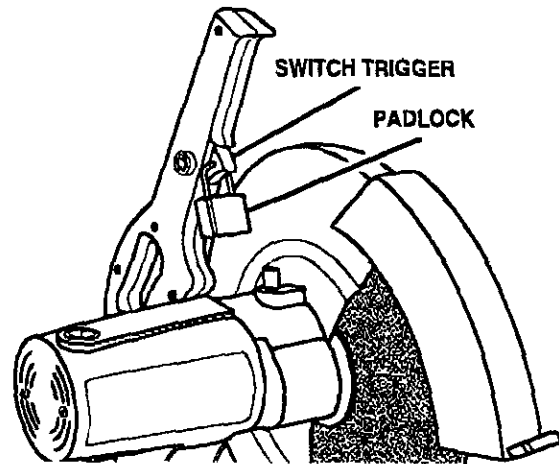

Fig. 4

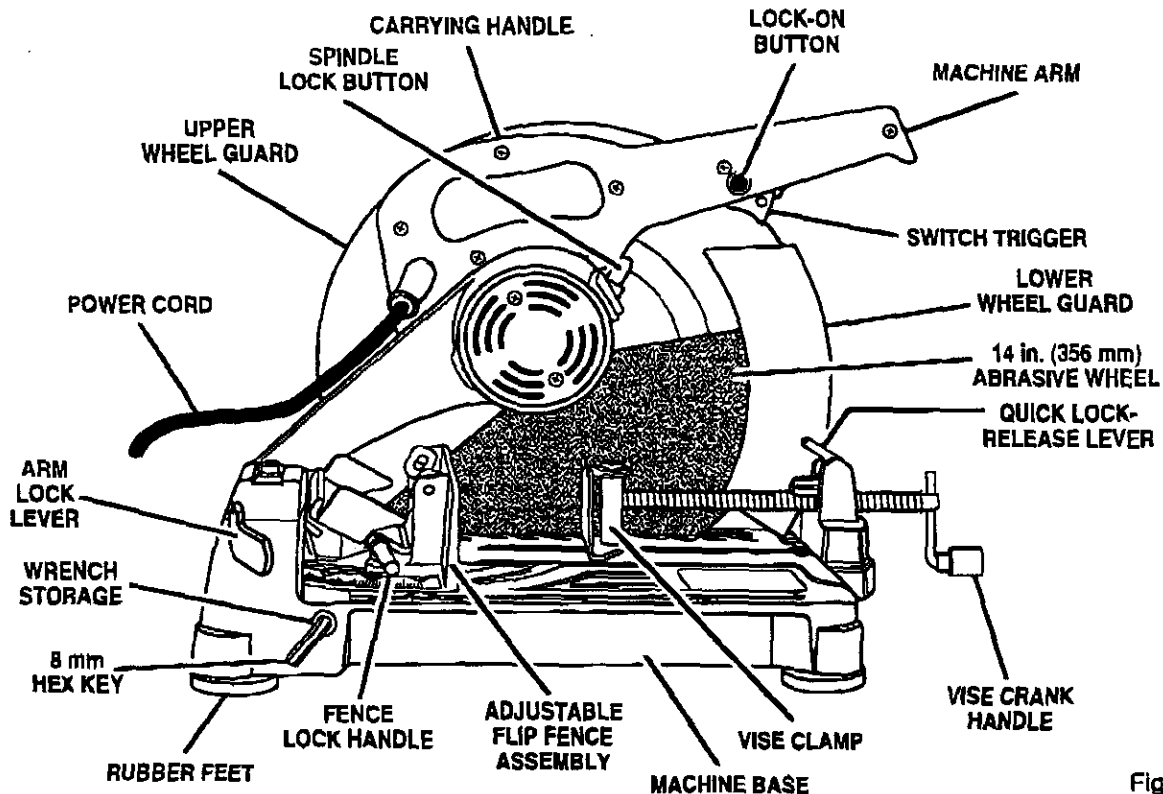

Fig. 3

ADJUSTMENTS

⚠ WARNING: To prevent accidental starting that could cause possible serious personal injury, assemble all parts to your cut-off machine before connecting it to power supply. Machine should never be connected to power supply when you are assembling parts, making adjustments, installing or removing wheels, or when not in use.

As mentioned previously your cut-off machine has been factory assembled and adjusted. After extended use and wear, the wheel will need to be replaced with a new one.

⚠ WARNING: A 14 in. (356 mm) wheel is the maximum wheel capacity of your cut-off machine. Never use a wheel that is too thick to allow outer flange to engage with the flats on the spindle. Larger wheels will come in contact with the wheel guards, while thicker wheels will prevent the bolt from securing the wheel on the spindle. Either of these situations could result in a serious accident and can cause serious personal injury.

REMOVAL AND INSTALLATION OF WHEEL

To Remove:

See Figure 5.

- Unplug your cut-off machine.

- ⚠ **WARNING:** Failure to unplug cut-off machine could result in accidental starting causing possible serious personal injury.
- Push down on machine arm and pull out arm lock lever to release machine arm.
- Raise machine arm to its full raised position. Be cautious when raising, machine arm is spring loaded.
- Rotate lower wheel guard upward, exposing 8 mm socket head bolt that secures abrasive wheel to wheel arbor.
- Depress the spindle lock button and rotate bolt until spindle locks, preventing shaft from rotating.
- Using the 8 mm hex key provided, loosen and remove bolt. **Note:** Bolt has right hand threads. Turn bolt counterclockwise to loosen.
- Remove outer washer, outer flange, spacer, and wheel. **Do not** remove inner flange or inner washer. Removal of these two parts are not required for wheel changes.

⚠ WARNING: If inner flange or inner washer has been removed, replace both before placing wheel on spacer and wheel arbor. Failure to do so could cause an accident since wheel will not tighten properly.

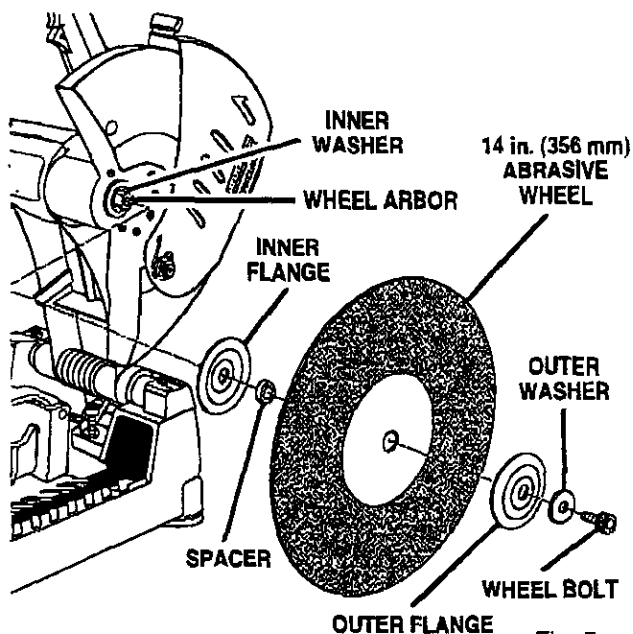

Fig. 5

To Install:

See Figure 5.

- Unplug your cut-off machine.

- ⚠ **WARNING:** Failure to unplug cut-off machine could result in accidental starting causing possible serious personal injury.
- Inspect the replacement wheel for defects such as cracks, chipping, and correct speed rating. If defects are found or the speed rating is not greater than 3300 rpm, do not use. Select another wheel.
- Clean debris from the inner washer and inner flange.
- Place new wheel over spacer, then place both on wheel arbor against inner flange.
- Clean outer flange, then align flats with flats on wheel arbor and slide it onto arbor until it is flush against wheel.
- Place recessed side of outer washer against arbor, then insert socket head bolt into threaded end of wheel arbor.
- Start threads and turn bolt clockwise to snugly tighten.
- Depress the spindle lock button and rotate bolt until spindle locks, preventing shaft from rotating.
- Using the 8 mm hex key provided, securely tighten socket head bolt. **Note:** Bolt has right hand threads. Turn bolt clockwise to tighten.
- ⚠ **WARNING:** Do not overtighten socket head bolt. Overtightening can cause the new wheel to crack, resulting in premature failure and possible serious personal injury.

ADJUSTMENTS

ADJUSTABLE FLIP FENCE ASSEMBLY

See Figure 6.

The adjustable flip fence assembly (see figure 6) is used along with the movable vise clamp to provide a clamp for holding your workpiece securely when making cuts. It also makes your cut-off machine more versatile.

The fence can be rotated to obtain cutting angles from 0° to 45°. It also has an extension block that flips up to allow greater cutting widths in thin stock, or down to allow greater cutting depths in tall or thick stock.

CUTTING ANGLE ADJUSTMENT

See Figure 6.

- Unplug your cut-off machine.

WARNING: Failure to unplug cut-off machine could result in accidental starting causing possible serious personal injury.

- Loosen the fence lock handle securing fence assembly.
- Rotate fence assembly until the desired angle of cut on the scale is aligned with the indicator in machine base.
- For precise cuts, check the angle of cut for the fence against the abrasive wheel with a protractor, bevel square, or other similar device.
- Using the fence lock handle, securely tighten the fence in place at desired angle. See Figure 6.

ADJUSTING WIDTH OF CUT

See Figures 7 and 8.

- Unplug your cut-off machine.

WARNING: Failure to unplug cut-off machine could result in accidental starting causing possible serious personal injury.

- To increase the width of cut of your cut-off machine, flip the extension fence up and back as shown in figure 7. This position is good for cutting thin and wide pieces of stock, such as flat or angled stock.
- To increase the height of cut of your cut-off machine, flip the extension fence down as shown in figure 8. This position is good for cutting tall and thick pieces of stock, such as square or tube stock.

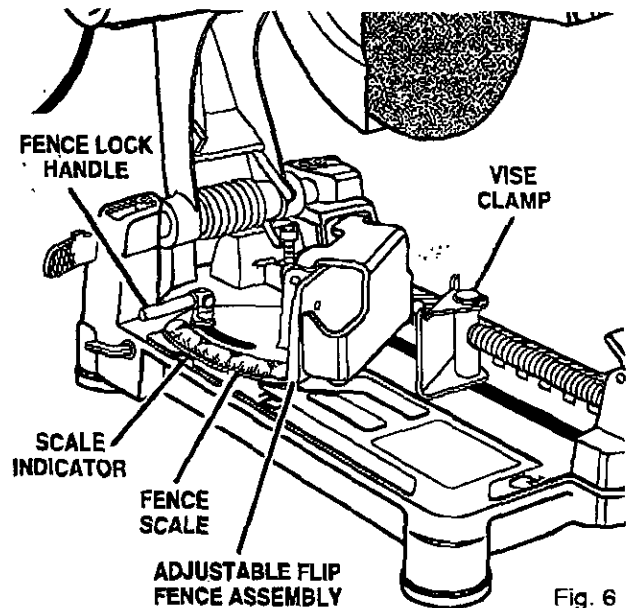

Fig. 6

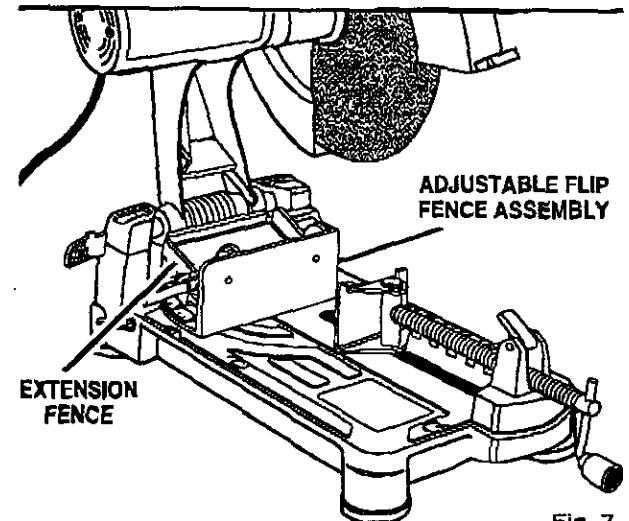

Fig. 7

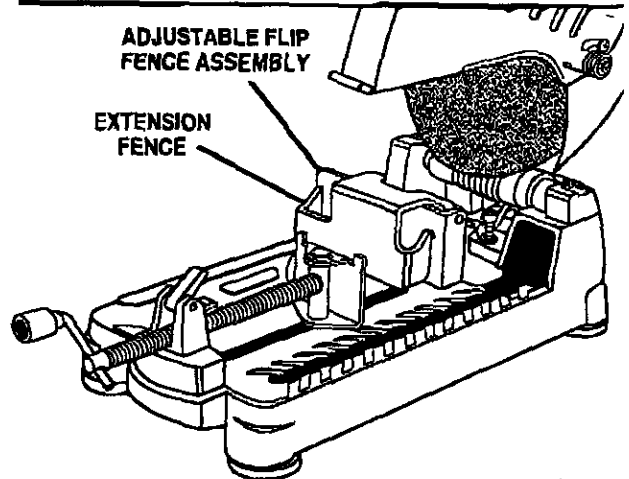

Fig. 8

ADJUSTMENTS

QUICK LOCK-RELEASE LEVER

See Figures 9 and 10.

The quick lock-release lever engages the vise clamp to be used along with the fence assembly to provide a vise for securing the workpiece to be cut. It also allows you to open and close the vise quickly without repetitive turning of the vise crank handle.

USING THE QUICK LOCK-RELEASE LEVER AND VISE CLAMP

To loosen:

See Figure 9.

- Unplug your cut-off machine.

⚠ WARNING: Failure to unplug cut-off machine could result in accidental starting causing possible serious personal injury.

- Release tension on the vise clamp by rotating the vise crank handle 1/2 to 1 turn counterclockwise.
- Lift up the quick lock-release lever as shown in figure 9 and pull back on vise crank handle to slide open the vise.

To tighten:

See Figure 10.

- Unplug your cut-off machine.

⚠ WARNING: Failure to unplug cut-off machine could result in accidental starting causing possible serious personal injury.

- Push the vise crank handle forward to slide the vise clamp against the workpiece.
- Rotate the quick lock-release lever forward and push down as shown in figure 10 to engage its threads with the vise screw.
- Rotate the vise crank handle clockwise to tighten the vise clamp against the workpiece.

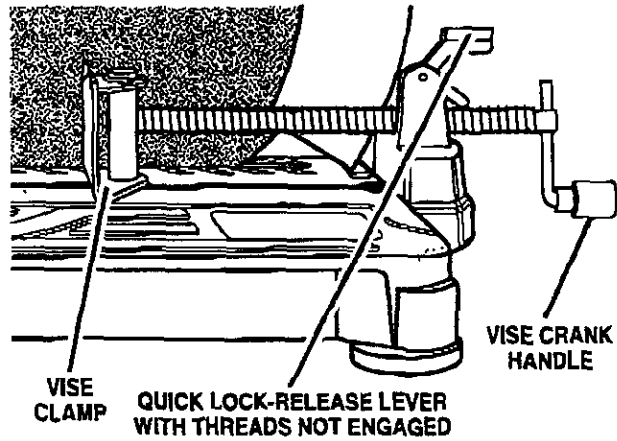

Fig. 9

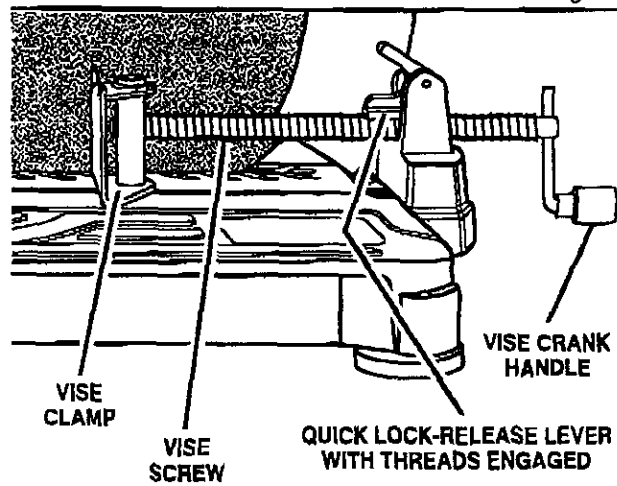

Fig. 10

ADJUSTMENTS

DEPTH STOP

The depth stop limits the wheel's downward travel. It allows the wheel to go below the machine base enough to maintain full cutting capacities.

The adjustable depth stop is a nylon bolt threaded into the base of the machine at the rear. To adjust the depth stop use an 8 mm wrench to raise or lower the depth stop bolt.

The depth stop is factory set to provide maximum cutting capacity for the 14 in. (356 mm) abrasive wheel provided with your cut-off machine.

When the diameter of the wheel has been reduced due to wear, it may be necessary to adjust the depth stop to provide maximum cutting capacity. When a new abrasive wheel is installed, it is necessary to check the clearance of the wheel to the machine base support.

DEPTH STOP ADJUSTMENTS

See Figure 11.

- Unplug your cut-off machine.

⚠ WARNING: Failure to unplug cut-off machine could result in accidental starting causing possible serious personal injury.

- Push the depth stop lever counterclockwise then loosen the depth stop bolt that is against the machine base.
- The depth stop is lowered by turning the depth stop bolt clockwise and raised by turning the bolt counterclockwise.
- By pressing down on the machine arm, lower the wheel and check clearance and maximum cutting distance (distance from adjustable stationary vise where wheel enters) to front of machine base slot.
- Adjust if necessary.

⚠ CAUTION: Do not start your abrasive cut-off machine without checking for interference between the wheel and the machine base support. Damage may result to the wheel if it strikes the machine base support during operation of the machine.

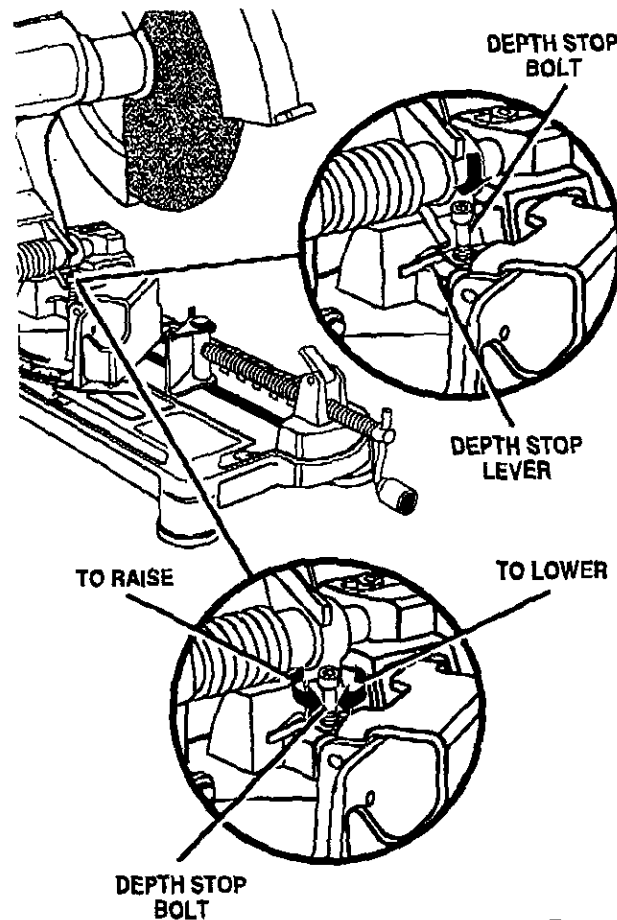

Fig. 11

- Tighten the depth stop bolt with the 8 mm hex key provided then push the depth stop lever clockwise.

⚠ WARNING: Cutting steel will cause sparks. Do not operate in the presence of combustible or flammable materials. Failure to heed this warning could result in a fire or serious personal injury.

OPERATION

APPLICATIONS

(Use only for the purposes listed below)

- Cutting all types of metals such as 2 in. x 6 in. steel framing studs.
- Cutting hard metal iron stock such as square bar stock and angle iron.

- Cutting metal tube and pipe stock.

OPERATION

POWER SUPPLY

Before operating your cut-off machine, check your power supply and make sure it meets the requirements listed on the tool's data plate. A substantial voltage drop will cause a loss of power and machine overheating.

Common causes of power loss and machine overheating are insufficient extension cord size and multiple tools operating from the same power source.

SWITCH

To turn your cut-off machine **ON**, depress the switch trigger located in the handle portion of the machine arm.

To turn it **OFF**, release the switch trigger.

LOCK-ON BUTTON

To engage the lock-on feature, depress the switch trigger, push in and hold the lock-on button located on the side of the handle, then release switch trigger. Release lock-on button and your machine will continue running.

To release the lock-on feature, depress the switch trigger and release.

If you have the lock-on feature engaged during use and your machine becomes disconnected from power supply, or in the event of a power failure, disengage the lock-on feature immediately.

CUTTING WITH YOUR CUT-OFF MACHINE

See Figures 12 and 13.

- ⚠ **WARNING:** Do not attempt to cut wood or masonry with this cut-off machine. Never cut magnesium or magnesium alloy with this machine. Failure to comply could result in serious personal injury.
- To prevent machine movement or tipping during cutting procedure, secure cut-off machine in place to a workbench or work surface that is also secure.
- ⚠ **WARNING:** Always use the vise on the cut-off machine to prevent accidents that could result in possible serious personal injury.
- ⚠ **WARNING:** Never stand or have any part of your body in line with the path of the wheel. Doing so may cause an accident resulting in possible serious personal injury.

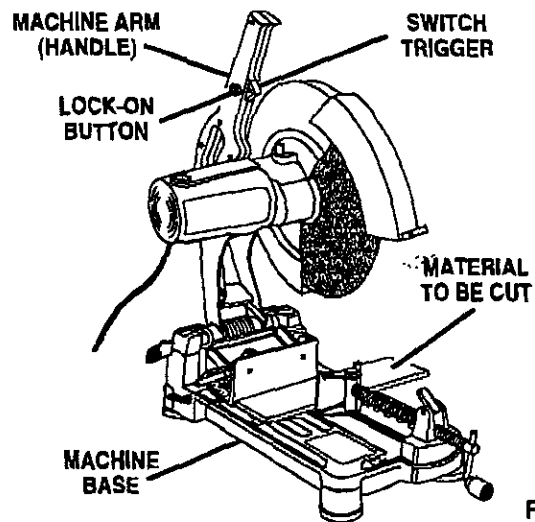

Fig. 12

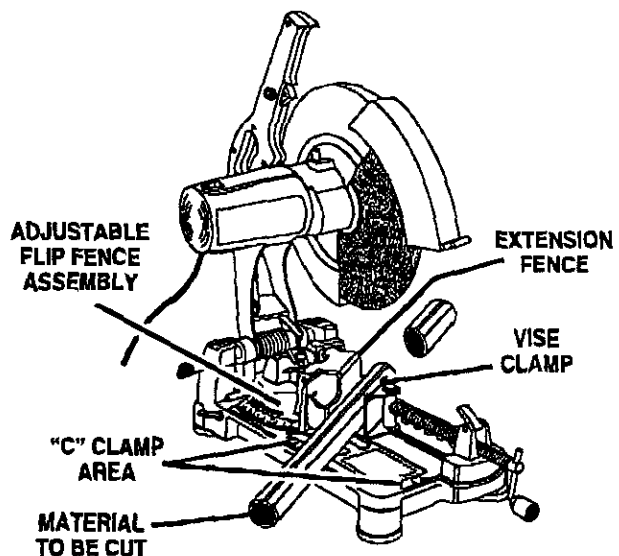

Fig. 13

- ⚠ **WARNING:** Large, circular, or irregularly shaped material may require additional means of clamping to be secured in place adequately for cutting. Use "C" clamps that can be mounted along the left and front side of the machine base. Also use blocks to hold material securely. Failure to comply could result in serious personal injury.
- ⚠ **WARNING:** To avoid accidental start up of your cut-off machine, always make sure switch is off and "lock-on" feature is disengaged before connecting to power source. Failure to heed this warning could result in serious personal injury.

OPERATION

CUT-OFF

See Figures 14 and 15.

A cut-off is made by cutting across the width of the workpiece. A straight crosscut is made with the adjustable flip fence set at the zero degree position. Angled cut-offs are made with the adjustable flip fence assembly set at some angle other than zero.

To cut with your cut-off machine:

- Firmly secure the material to be cut using the machine's vise (adjustable flip fence assembly, extension fence, and vise clamp).
- Using the fence lock handle, loosen the adjustable flip fence assembly. See Figures 14 and 15.
- Rotate the adjustable flip fence assembly to the angle needed.
- Retighten fence lock handle.

⚠ WARNING: To avoid serious personal injury, always tighten fence lock handle securely before making a cut. Failure to do so could result in movement of the workpiece while making a cut.

- Place the workpiece flat on the machine base with one surface securely against the adjustable flip fence.
- Align cutting line on the workpiece with the edge of the abrasive wheel.
- Push in the vise crank handle to set the vise clamp against the workpiece. Turn the vise crank handle 1/2 to 1 turn clockwise to securely clamp the workpiece to the fence.

⚠ WARNING: To avoid serious personal injury, keep your hands at least 3 in. (76.2 mm) from wheel.

- When cutting long pieces, support the opposite end of the material with a roller stand or with a work surface level with the machine base.

⚠ WARNING: Never perform any cutting operation freehand (without placing workpiece in the vise). Material will get hot during cutting operation. Keep hands off of metal being cut to avoid serious personal injury.

- Before turning on machine, perform a dry run of the cutting operation just to make sure that no problems will occur when the cut is made.
- Start the machine by grasping the handle and fully squeezing the switch trigger. Allow several seconds for the wheel to build up to full speed before letting it come into contact with the material to be cut.

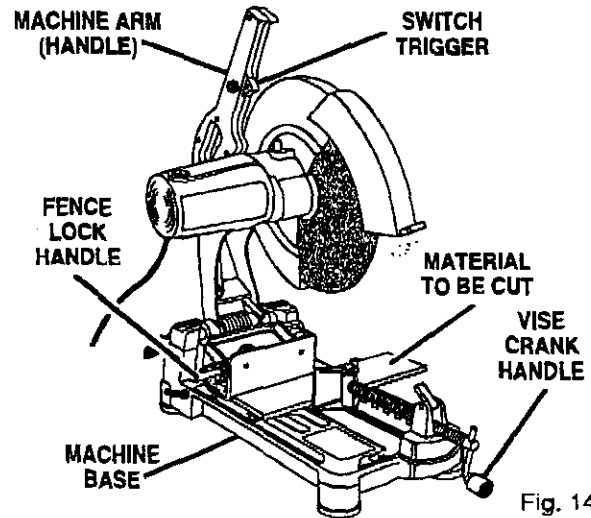

Fig. 14

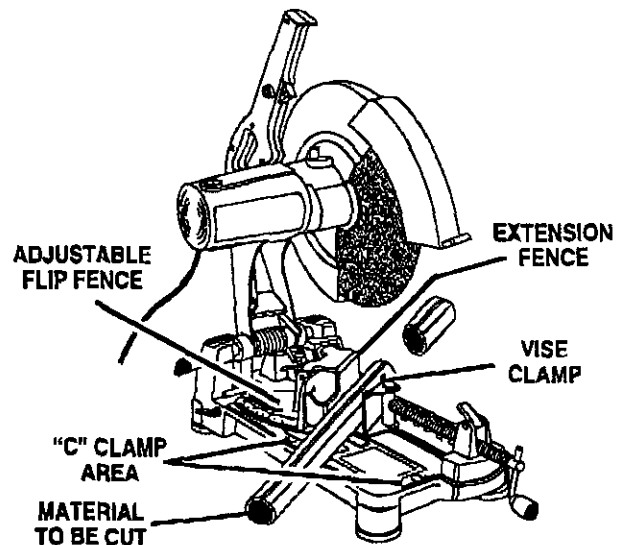

Fig. 15

- Once it reaches full speed slowly lower the handle of the machine arm until the cut-off wheel comes in contact with the material being cut. Continue to use steady and even pressure to obtain a uniform cut through the workpiece. Never force the wheel into the material being cut.
- When the cut is complete, release the switch trigger and allow the wheel to stop rotating before raising the wheel out of workpiece.

⚠ WARNING: Do not touch the cut material until it cools or you can be burned. Failure to heed this warning could result in serious personal injury.

OPERATION

MOUNTING HOLES

Your cut-off machine should be permanently mounted to a firm supporting surface such as workbench. The four bolt holes that secure the feet on the bottom of the base can be used for this purpose. Using a 6 mm hex key, remove bolts, washers, and feet from bottom of cut-off machine. The four mounting holes should be bolted securely using 8 mm machine bolts, lock washers, and flat washers (not included). Bolts should be of sufficient length to accommodate lock washers, flat washers, thickness of the workbench, and sufficiently engage bolt hole threads in bottom of the base.

Tighten all four bolts securely.

The hole pattern for mounting to a workbench is shown in figure 16. Carefully check the workbench after mounting to make sure that no movement can occur during use. If any tipping, sliding, or walking is noted, secure work bench to the floor before operating.

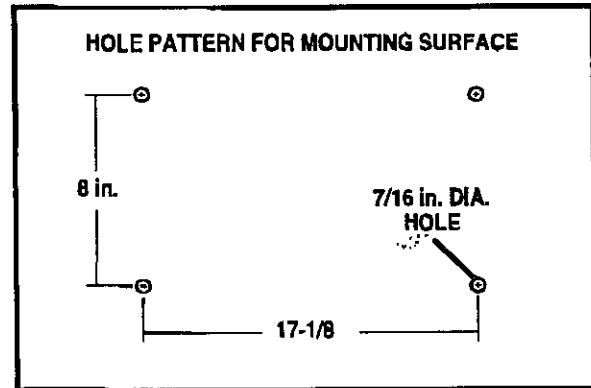

Fig. 16

WARNING: Always make sure your cut-off machine is securely mounted to a workbench or an approved workstand. Failure to do so could result in an accident resulting in possible serious personal injury.

MAINTENANCE

WARNING: When servicing, use only identical Sears replacement parts. Use of any other part may create a hazard or cause product damage.

GENERAL

Avoid using solvents when cleaning plastic parts. Most plastics are susceptible to damage from various types of commercial solvents and may be damaged by their use. Use a clean cloth to remove dirt, carbon dust, etc.

CAUTION: Do not at any time let brake fluids, gasoline, petroleum-based products, penetrating oils, etc. come in contact with plastic parts. They contain chemicals that can damage, weaken or destroy plastic.

LUBRICATION

All of the bearings in this tool are lubricated with a sufficient amount of high grade lubricant for the life of the unit under normal operating conditions. Therefore, no further lubrication is required.

EXTENSION CORDS

The use of any extension cord will cause some loss of power. To keep the loss to a minimum and to prevent tool overheating, use an extension cord that is heavy enough to carry the current the tool will draw.

A wire gage size (A.W.G.) of at least 14 is recommended for an extension cord 25 feet or less in length. When working outdoors, use an extension cord that is suitable for outdoor use. The cord's jacket will be marked WA.

WARNING: Keep extension cords away from the cutting area and position the cord so that it will not get caught on materials, tools, etc., during cutting operation.

WARNING: Check extension cords before each use. If damaged, replace immediately. Never use tool with a damaged cord since touching the damaged area could cause electrical shock resulting in serious injury.

WARNING: Always wear safety goggles or safety glasses with side shields during power tool operation or when blowing dust. If operation is dusty, also wear a dust mask.

MAINTENANCE

⚠ WARNING: To ensure safety and reliability, all repairs — with the exception of the externally accessible brushes — should be performed by a Sears Authorized Service Center.

BRUSH REPLACEMENT

See Figure 17.

Your cut-off machine has externally accessible brush assemblies that should be periodically checked for wear.

Proceed as follows when replacement is required:

- Unplug your cut-off machine.

⚠ WARNING: Failure to unplug cut-off machine could result in accidental starting causing possible serious personal injury.

- Remove brush cap with a screwdriver. Brush assembly is spring loaded and will pop out when you remove brush cap.
- Remove brush assembly.
- Check for wear. Replace both brushes when either has less than 1/4 in. length of carbon remaining. **Do not** replace one side without replacing the other.
- Reassemble using new brush assemblies. Make sure curvature of brush matches curvature of motor and that brush moves freely in brush tube.

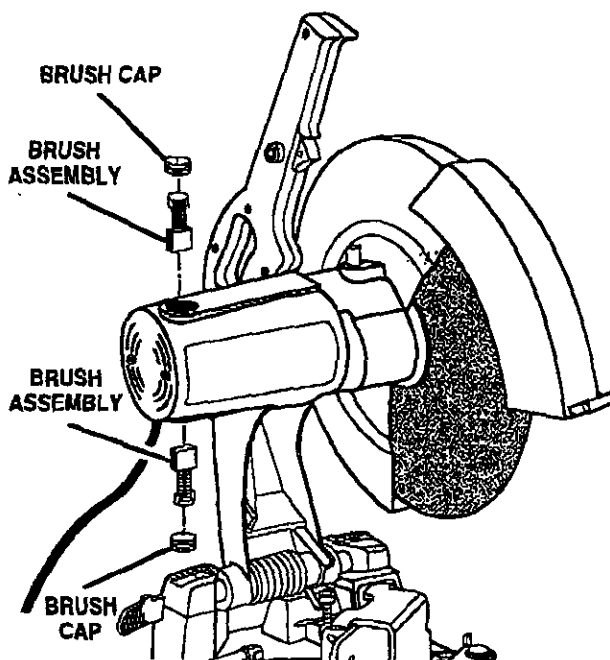

Fig. 17

- Make sure brush cap is oriented correctly (straight) and replace.
- Tighten brush cap securely. **Do not** overtighten.

TROUBLESHOOTING

PROBLEM	CAUSE	SOLUTION
Machine does not start	<ol style="list-style-type: none"> 1. Power cord not plugged in. 2. Power cord is damaged. 3. Circuit breaker is tripped. 4. Circuit fuse is blown 5. Switch is damaged or burned out. 	<ol style="list-style-type: none"> 1. Plug in cord. 2. Have the cord replaced at your nearest authorized service center. 3. Reset circuit breaker. 4. Replace circuit fuse. 5. Have the switch replaced at your nearest authorized service center and request a voltage check from the power company.

TROUBLESHOOTING

PROBLEM	CAUSE	SOLUTION
Motor does not reach full speed or power.	<ol style="list-style-type: none"> 1. Voltage from power source is low. 2. Circuit is overloaded. out anything else on circuit. 3. Motor burned out. 4. Fuses or circuit breakers are wrong size. 5. Extension cord is too long. 6. Switch is defective. 	<ol style="list-style-type: none"> 1. Request a voltage check from the power company. 2. Test on a different circuit or without anything else on circuit. 3. Have tool serviced and request a voltage check from the power company. 4. Have an electrician replace with a 15 amp fuse or circuit breaker 5. Use a shorter extension cord. 6. Have the switch replaced at your nearest authorized service center.
Motor stalls, blows fuses, or trips circuit breakers	<ol style="list-style-type: none"> 1. Switch is defective 2. Voltage from source is low. 3. Fuses or circuit breakers are wrong size or defective. 	<ol style="list-style-type: none"> 1. Have the switch replaced at your nearest authorized service center. 2. Request a voltage check from the power company. 3. Have an electrician replace with a 15 amp fuse or circuit breaker
Motor overheats.	<ol style="list-style-type: none"> 1. Motor is overloaded. 2. Wheel is being fed into work too fast. 	<ol style="list-style-type: none"> 1. Request a voltage check from the power company. 2. Feed wheel into work slower
Machine is noisy when running.	<ol style="list-style-type: none"> 1. Motor needs attention. 	<ol style="list-style-type: none"> 1. Have the motor checked at your nearest authorized service center
Wheel hits table	<ol style="list-style-type: none"> 1. Wheel not properly installed. 2. Depth stop setting incorrect. 	<ol style="list-style-type: none"> 1. See "Removal And Installation Of Wheel" section. 2. Adjust the depth stop. See "Depth Stop" section.
Wheel does not cut through workpiece	<ol style="list-style-type: none"> 1. Depth stop setting incorrect. 2. Wheel worn too much. 3. Incorrect cutting operation. 	<ol style="list-style-type: none"> 1. Adjust the depth stop. See "Depth Stop" section. 2. Replace with a new 14-in. abrasive cut off wheel. 3. See "cut-off" section.
Machine vibrates or shakes excessively.	<ol style="list-style-type: none"> 1. Wheel is out-of-round. 2. Wheel is chipped 3. Wheel is loose. 4. Machine is not secure. 5. Work surface is uneven. surface. 	<ol style="list-style-type: none"> 1. Replace wheel. 2. Replace wheel. 3. Tighten wheel bolt on arbor 4. Check and tighten all hardware. 5. Relocate and secure on a flat

CRAFTSMAN 14 in. (356 mm) ABRASIVE CUT-OFF MACHINE – MODEL NO. 212900

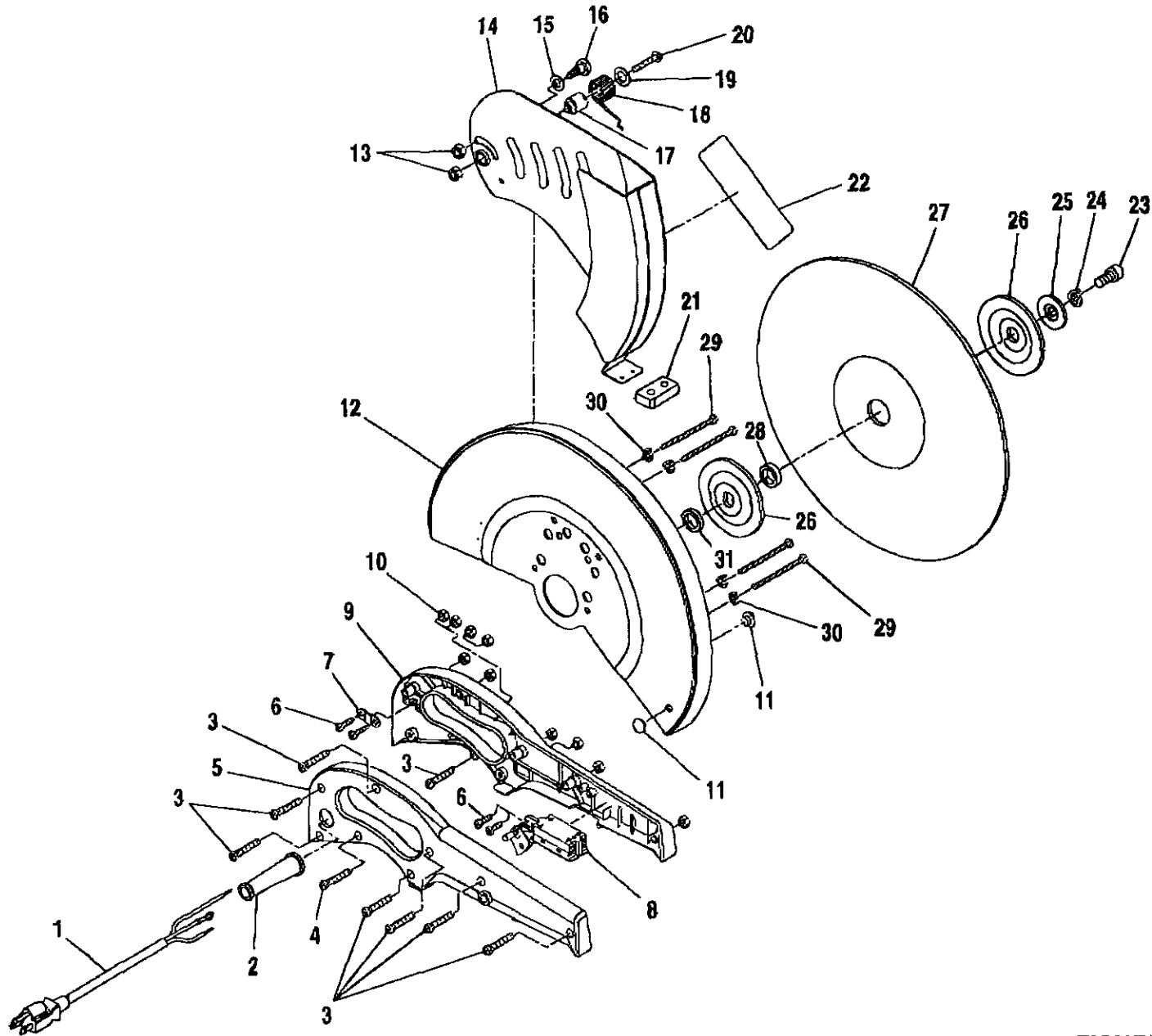

FIGURE A

CRAFTSMAN 14 in. (356 mm) ABRASIVE CUT-OFF MACHINE – MODEL NO. 212900

The model number will be found on a plate attached to the motor housing. Always mention the model number in all correspondence regarding your Cut-Off Machine or when ordering repair parts.

PARTS LIST FOR FIGURE A

Key No.	Part Number	Description	Quan.	Key No.	Part Number	Description	Quan.
1	C357085-BB	Power Cord (14 AWG)	1	17	C357020-BB	Spring Pin	1
2	C357084-BB	Bend Relief	1	18	C357017-BB	Spring	1
3	C2600066-BB	* Screw (M5 X 24)	8	19	C2600007-BB	* Washer (M1)	1
4	C2600067-BB	* Screw (M5 X 22)	1	20	C2600008-BB	* Screw (M6 X 30)	1
5	C357075-BB	Left Handle	1	21	C357021-BB	Plastic Cover	1
6	C2600068-BB	* Screw	4	22	C2600072-BB	Logo Plate	1
7	C357071-BB	Cord Clamp	1	23	C2600005-BB	Wheel Bolt (M10 X 20)	1
8	C357083-BB	Switch	1	24	C2600004-BB	Spring Washer	1
9	C357078-BB	Right Handle	1	25	C357011-BB	Outer Washer	1
10	C2600070-BB	* Nut (M5)	9	26	C357010-BB	Flange Washer	2
11	C357007-BB	Bumper	2	27	C357009-BB	Wheel	1
12	C357001-BB	Upper Blade Guard	1	28	C357006-BB	Spacer	1
13	C2600006-BB	Lock Nut (M6)	2	29	C2600002-BB	* Screw (M6 X 78)	4
14	C357014-BB	Lower Blade Guard	1	30	C2600001-BB	* Spring Washer (M6)	4
15	C357015-BB	* Washer (M3)	1	31	C357005-BB	Inner Washer	1
16	C357016-BB	* Screw (M6 X16)	1				

* STANDARD HARDWARE ITEM — MAY BE PURCHASED LOCALLY

CRAFTSMAN 14 in. (356 mm) ABRASIVE CUT-OFF MACHINE - MODEL NO. 212900

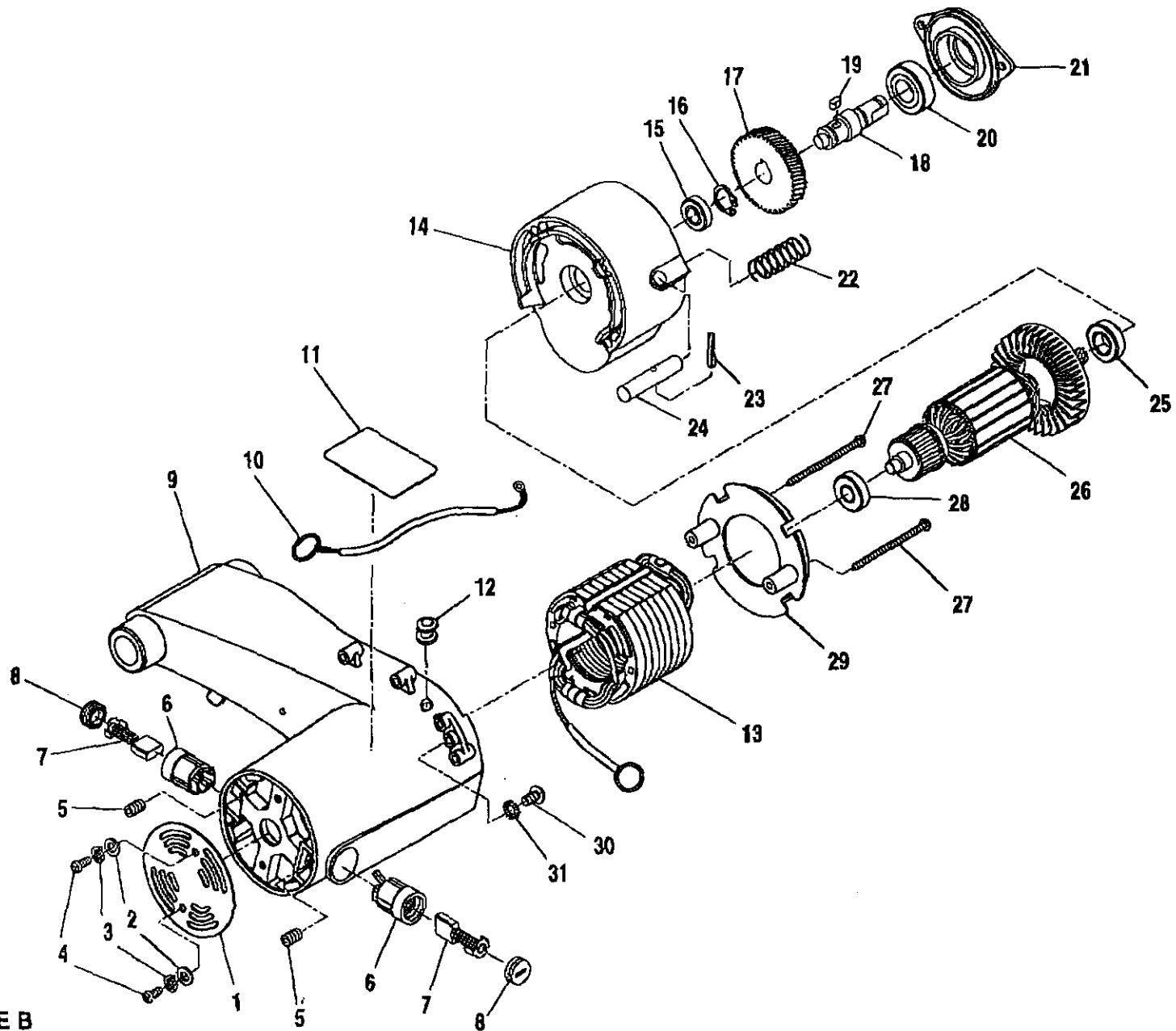

FIGURE B

CRAFTSMAN 14 in. (356 mm) ABRASIVE CUT-OFF MACHINE – MODEL NO. 212900

The model number will be found on a plate attached to the motor housing. Always mention the model number in all correspondence regarding your Cut-Off Machine or when ordering repair parts.

PARTS LIST FOR FIGURE B

Key No.	Part Number	Description	Quan.	Key No.	Part Number	Description	Quan.
1	C357026-BB	End Cap	1	17	C357046-BB	Gear	1
2	C2600011-BB	* Flat Washer (M5)	2	18	C357048-BB	Gear Shaft	1
3	C2600010-BB	* Spring Washer (M5)	2	19	C2600023-BB	Flat Pin (M5 X 10)	1
4	C2600009-BB	* Screw (M5 X 12)	2	20	C2600024-BB	Ball Bearing (6203)	1
5	C2600012-BB	* Screw (M5 X 12)	2	21	C357054-BB	Gear Cover	1
6	C357025-BB	Brush Holder	2	22	C357050-BB	Spring	1
7	C357024-BB	Brush Assembly	2	23	C2600025-BB	Roll Pin	1
8	C357023-BB	Brush Cap	2	24	C357051-BB	Stop Pin	1
9	C357022-BB	Motor Housing	1	25	C2600020-BB	Ball Bearing (6002)	1
10	C357030-BB	Lead Wire	1	26	C357041-BB	Armature Assembly	1
11	C2600014-BB	Data Plate	1	27	C2600018-BB	* Screw (M5 X 75)	2
12	C2600013-BB	Grommet	1	28	C2600019-BB	Ball Bearing	1
13	C357036-BB	Field Assembly	1	29	C357037-BB	Fan Baffle	1
14	C357044-BB	Gear Case	1	30	C2600017-BB	* Screw (M5 X 12)	1
15	C2600021-BB	Ball Bearing (6000)	1	31	C2600016-BB	* Star Washer (M5)	1
16	C2600022-BB	Retaining Ring	1				

* STANDARD HARDWARE ITEM — MAY BE PURCHASED LOCALLY

CRAFTSMAN 14 in. (356 mm) ABRASIVE CUT-OFF MACHINE - MODEL NO. 212900

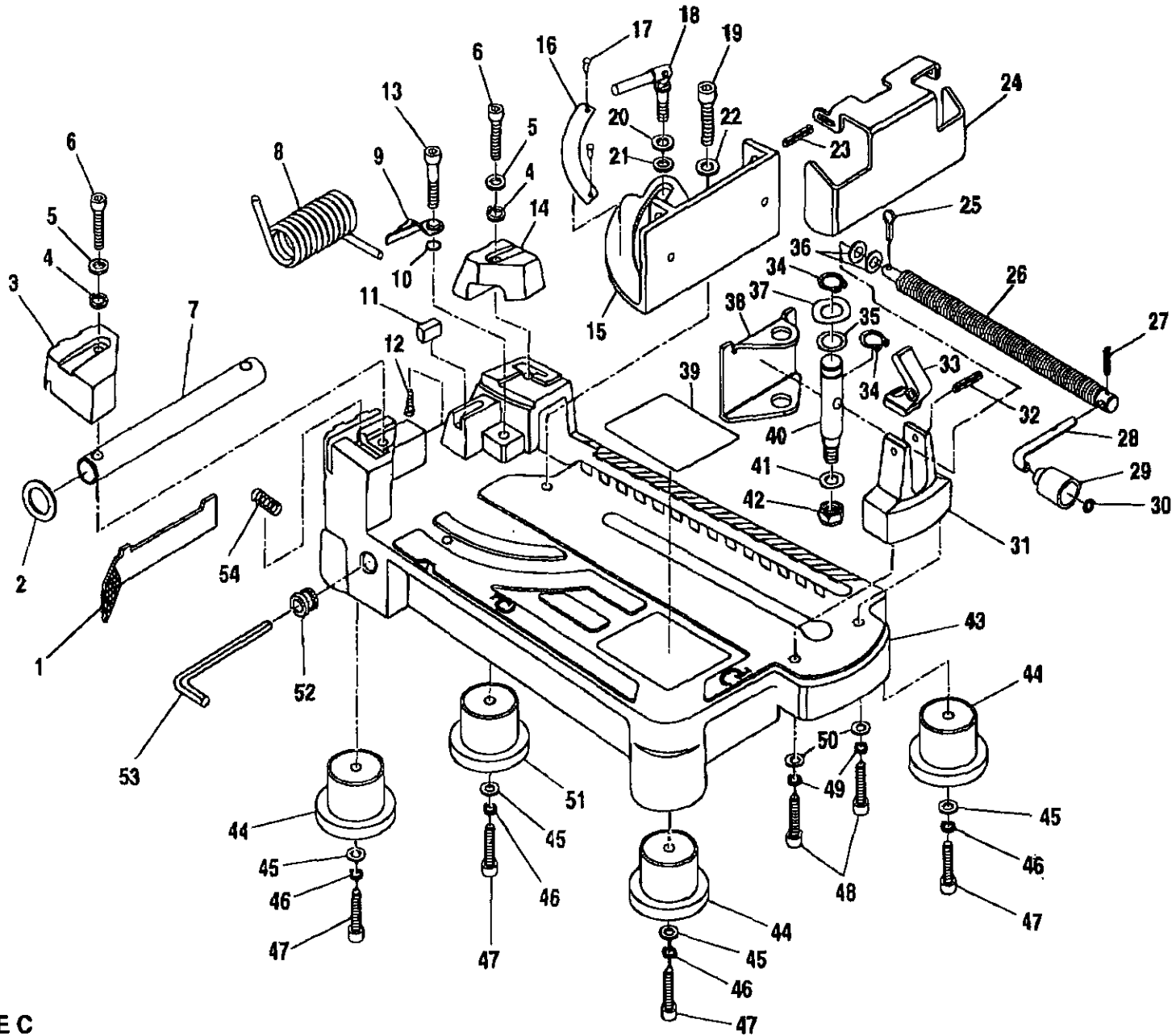

FIGURE C

CRAFTSMAN 14 in. (356 mm) ABRASIVE CUT-OFF MACHINE – MODEL NO. 212900

The model number will be found on a plate attached to the motor housing. Always mention the model number in all correspondence regarding your Cut-Off Machine or when ordering repair parts.

PARTS LIST FOR FIGURE C

Key No.	Part Number	Description	Quan.	Key No.	Part Number	Description	Quan.
1	C2600046-BB	Lever	1	28	C357080-BB	Handle	1
2	C2600029-BB	* Flat Washer (M6)	1	29	C357081-BB	Handle Cover	1
3	C357058-BB	Left Cover	1	30	C2600061-BB	Ring	1
4	C2600027-BB	* Spring Washer (M8)	2	31	C2600056-BB	Yoke	1
5	C2600028-BB	Flat Washer	2	32	C2600054-BB	* Roll Pin (M6 X 30)	1
6	C2600026-BB	* Socket Hex Head Screw (M8 X 40)	2	33	C357094-BB	Quick Lock-Release Lever	1
7	C357060-BB	Pivot Shaft	1	34	C2600059-BB	* Retaining Ring (M18)	2
8	C2600031-BB	Spring	1	35	C357087-BB	* Washer	1
9	C357114-BB	Lock Wrench	1	36	C2600064-BB	* Washer	2
10	C357110-BB	Flat Washer	1	37	C2600060-BB	* Spring Washer (M18)	2
11	C2600071-BB	Position Stop	1	38	C357095-BB	Vise Clamp	1
12	C2600050-BB	Screw (M6 x 30)	1	39	C357093-BB	Warning Label	1
13	C2600032-BB	* Socket Hex Head Screw (M10 X 70)	1	40	C357089-BB	Pin	1
14	C2600033-BB	Right Cover	1	41	C2600058-BB	* Flat Washer (M1)	1
15	C2600038-BB	Fence	1	42	C2600057-BB	* Hex Lock Nut (M12)	1
16	C2600034-BB	Scale	1	43	C2600055-BB	Base	1
17	C2600035-BB	Scale Rivet	2	44	C2600042-BB	Rubber Foot	4
18	C2600047-BB	Lock Handle	1	45	C2600043-BB	* Washer	4
19	C2600036-BB	* Hex Socket Screw (M10 X 20)	1	46	C2600044-BB	* Washer	4
20	C2600048-BB	* Spring Washer	1	47	C2600045-BB	Screw (M8 x 42)	4
21	C2600049-BB	* Washer	1	48	C2600051-BB	* Hex Socket Screw (M8 x 25)	2
22	C2600037-BB	* Washer (M10)	1	49	C2600052-BB	Spring Washer	2
23	C2600039-BB	Roller Pin (M6 x 20)	1	50	C2600053-BB	* Washer	2
24	C2600040-BB	Extension Fence	1	51	C2600041-BB	Metal Foot Cover	1
25	C2600065-BB	Pin	1	52	C357120-BB	Hex Key Holder	1
26	C2600063-BB	Threaded Rod (M18 X 344)	1	53	C357091-BB	Hex Key	1
27	C2600062-BB	* Roll Pin (M3 X 14)	1	54	C2600030-BB	Spring	1

* STANDARD HARDWARE ITEM — MAY BE PURCHASED LOCALLY

Get it fixed at your home or ours!

For repair of major brand appliances in your own home...
no matter who made it, no matter who sold it!

1-800-4-MY-HOMESM Anytime, day or night
(1-800-469-4663)

www.sears.com

To bring in products such as vacuums, lawn equipment and electronics
for repair, call for the location of your nearest **Sears Parts & Repair Center.**

1-800-488-1222 Anytime, day or night

www.sears.com

For the replacement parts, accessories and owner's manuals
that you need to do-it-yourself, call **Sears PartsDirectSM!**

1-800-366-PART 6 a.m. – 11 p.m. CST,
(1-800-366-7278) 7 days a week

www.sears.com/partsdirect

To purchase or inquire about a Sears Service Agreement:

1-800-827-6655

7 a.m. – 5 p.m. CST, Mon. – Sat.

Para pedir servicio de reparación a domicilio,
y para ordenar piezas con entrega a domicilio:

1-888-SU-HOGARSM
(1-888-784-6427)

Au Canada pour service en français:

1-877-LE-FOYERSM
(1-877-533-6937)

SEARS
HomeCentralSM