

OVEN CIRCUIT // CIRCUIT DU FOUR

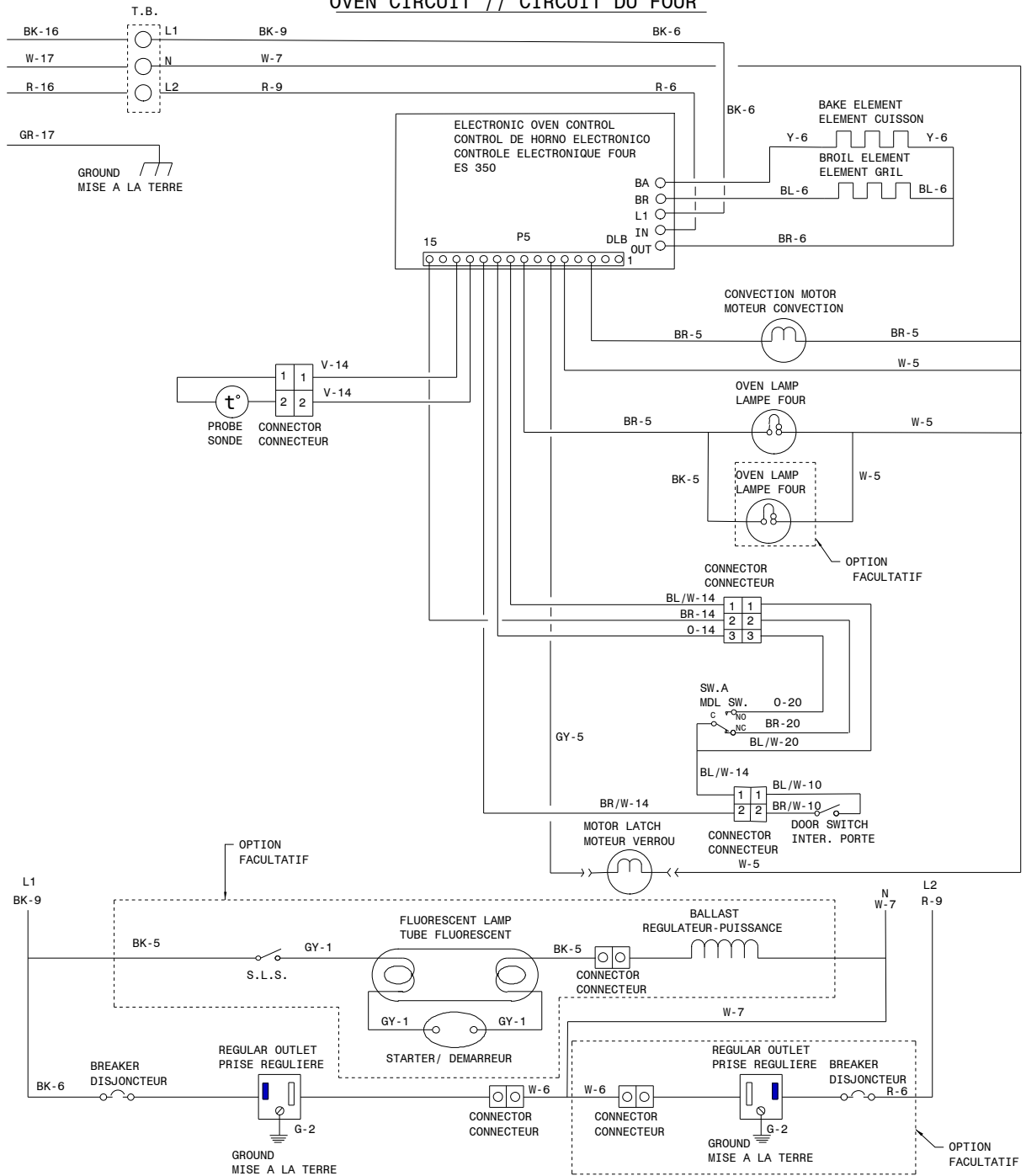

LEGEND/LEGENDE
 SW. - SWITCH/INTERRUPTEUR
 R.F. - RIGHT FRONT/AVANT DROIT
 R.R. - RIGHT REAR/ARRIERE DROIT
 L.F. - LEFT FRONT/AVANT GAUCHE
 L.R. - LEFT REAR/ARRIERE GAUCHE
 P.L. - PILOT LIGHT/LAMPE TEMOIN
 LIM. - LIMITOR/LIMITEUR
 W.Z. - WARMER ZONE/ZONE RECHAUD
 UIB. - UNIT INTERFACE BOARD/PLAQUETTE INTERFACE
 H.S. - HOT SURFACE/SURFACE CHAUDE
 T.B. - TERMINAL BLOCK/BLOC DE CONNECTION
 MDL. - MOTOR DOOR LATCH/MOTEUR PORTE VERROU
 S.L.S. - SURFACE LAMP SWITCH/INTERRUPTEUR LAMPE - SURFACE

COLOR CODE/CODE DE COULEUR
 G. - GREEN/VERT
 W. - WHITE/BLANC
 R. - RED/ROUGE
 O. - ORANGE/ORANGE
 Y. - YELLOW/JAUNE
 BR. - BROWN/BRUN
 BL. - BLUE/BLEU
 BK. - BLACK/NOIR

WIRE FIL	GAUGE CALIBRE	TEMP. °C	CSA	UL
1	18	125	CL1251	3173
2	16	125	CL1251	3173
3	14	125	CL1251	3173
4	12	125	CL1251	3173
5	18	150	EXL-150	3321
6	16	150	EXL-150	3321
7	14	150	EXL-150	3321
8	12	150	EXL-150	3321
9	10	150	EXL-150	3321
10	18	200	SEW-1	3122
11	16	200	SEW-1	3122
12	12	250		3252
13	16	250		3252
14	20	150	EXL-150	3321
15	8	150	EXL-150	3321

WIRE FIL	GAUGE CALIBRE	TEMP. °C	CSA	UL
16	8	60		
17	10	60		
18	10	200	SEW-1	3122
19	20	125	SEW-1	3173
20	20	200	SEW-1	3122
21	22	125	CL-1252	3266

CAUTION: DISCONNECT POWER BEFORE SERVICING UNIT.
ATTENTION: COUPEZ L'ALIMENTATION AVANT D'EFFECTUER LA REPARATION.

318046782 REV:A
SHEET/FEUILLE: 1/2

SURFACE-ELEMENT-CIRCUIT/CIRCUIT ELEMENT SURFACE
SMOOTH TOP WITH ONE DOUBLE ELEMENT/THREE SINGLES//
VITRIFIEE AVEC UN ELEMENT DOUBLE//TROIS SIMPLES

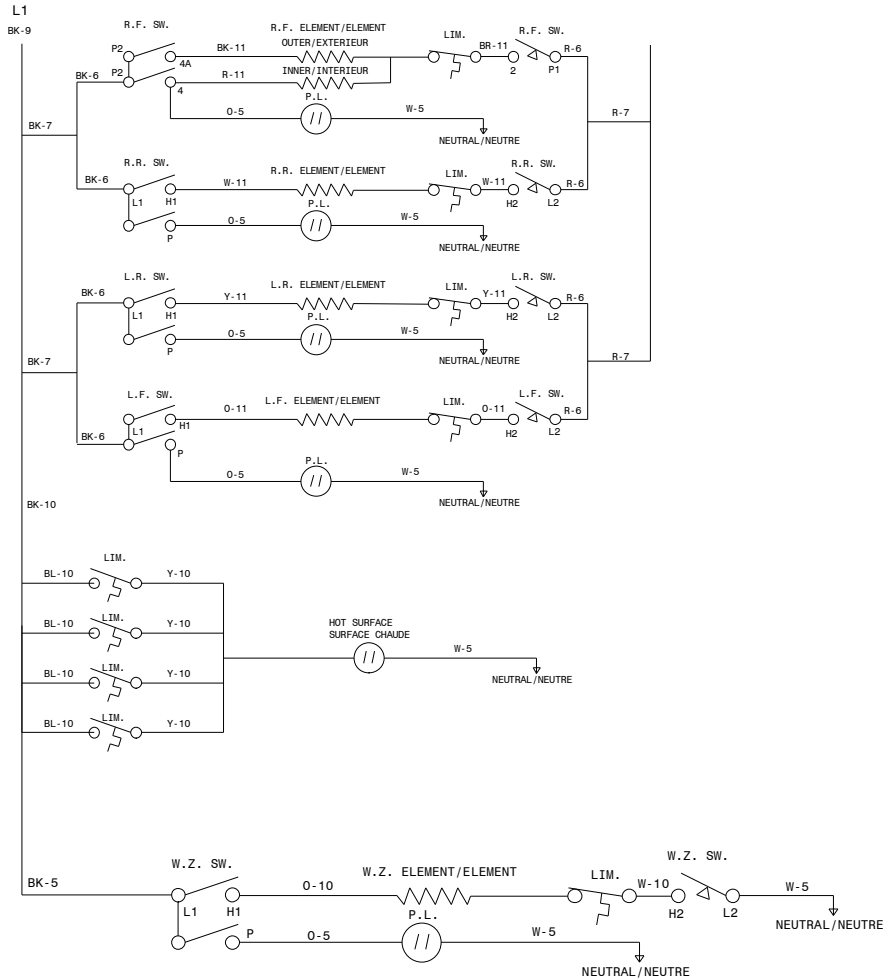

LIMITER/LIMITEUR
E.G.O./A.K.O.

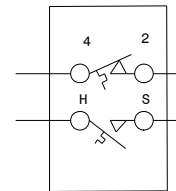

LIMITER/LIMITEUR
CERAMASPEED/EIKA

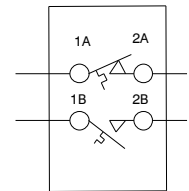

CAUTION: DISCONNECT POWER BEFORE SERVICING UNIT.
ATTENTION: COUPEZ L'ALIMENTATION AVANT D'EFFECTUER LA REPARATION.

318046782 REV:A
SHEET/FEUILLE:2/2