

Owner's Manual

Stainless Steel
Professional Island
Range Hood

Models:

ZV42

ZV54

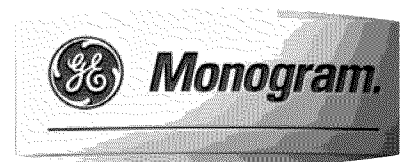

Contents

Consumer Information

Important Phone Numbers 11
 Model and Serial Numbers..... 2
 Problem Solver..... 9, 10
 Product Registration 2
 Safety Instructions 3, 4, 6
 Warranty Back Cover

Controls and Features..... 5

Care and Cleaning

Baffle Grease Filters.....7
 Drip Trays7
 Light Bulbs..... 6
 Stainless Steel Surfaces8

Before using your stainless steel hood

Read this manual carefully. It is intended to help you operate and maintain your new professional range hood properly.
 Keep it handy for answers to your questions.

If you don't understand something or need more help, there is a list of toll-free consumer service numbers included in the back section of this manual.

Visit our Website at: **GEAppliances.com**

Write down the model & serial numbers

You'll find them on a label on the hood.

These numbers are also on the Consumer Product Ownership Registration Card packed separately with your hood.

Use these numbers in any correspondence or service calls concerning your hood.

Before sending in this card, please write these numbers here:

Model Number

Serial Number

If you received a damaged hood

Immediately contact the dealer (or builder) that sold you the hood.

Save time & money

Before you request service, check the Problem Solver in the back of this manual.

It lists causes of minor operating problems that you can correct yourself.

If you need service

To obtain service, see the Consumer Services page in the back of this manual.

We're proud of our service and want you to be pleased. If for some reason you are not happy with the service you receive, here are some steps to follow for further help.

FIRST, contact the people who serviced your appliance. Explain why you are not pleased. In most cases, this will solve the problem.

NEXT, if you are still not pleased, write all the details—including your phone number—to:

Manager, Customer Relations
 GE Appliances
 Appliance Park
 Louisville, KY 40225

IMPORTANT SAFETY INSTRUCTIONS

READ ALL INSTRUCTIONS BEFORE USING

SAFETY PRECAUTIONS

⚠WARNING: TO REDUCE THE RISK OF FIRE, ELECTRIC SHOCK OR INJURY TO PERSONS, OBSERVE THE FOLLOWING:

- A. Use this unit only in the manner intended by the manufacturer. If you have questions, contact the manufacturer.
- B. Before servicing or cleaning unit, switch power off at service panel and lock the service disconnecting means to prevent power from being switched on accidentally. When the service disconnecting means cannot be locked, securely fasten a prominent warning device, such as a tag, to the service panel.
- C. Do not use this unit with any solid-state speed control device.
- D. This unit must be grounded.

⚠CAUTION: FOR GENERAL VENTILATING USE ONLY. DO NOT USE TO EXHAUST HAZARDOUS OR EXPLOSIVE MATERIALS AND VAPORS.

⚠WARNING: TO REDUCE THE RISK OF INJURY TO PERSONS IN THE EVENT OF A RANGE TOP GREASE FIRE, OBSERVE THE FOLLOWING*:

- A. SMOTHER FLAMES with a close-fitting lid, cookie sheet or metal tray, then turn off the burner. BE CAREFUL TO PREVENT BURNS. If the flames do not go out immediately, EVACUATE AND CALL THE FIRE DEPARTMENT.
- B. NEVER PICK UP A FLAMING PAN—You may be burned.
- C. DO NOT USE WATER, including wet dishcloths or towels—a violent steam explosion will result.
- D. Use an extinguisher ONLY if:
 - 1. You know you have a Class ABC extinguisher, and you already know how to operate it.
 - 2. The fire is small and contained in the area where it started.
 - 3. The fire department is being called.
 - 4. You can fight the fire with your back to an exit.

*Based on “[Kitchen Firesafety Tips](#)” published by NFPA.

⚠WARNING: TO REDUCE THE RISK OF A RANGE TOP GREASE FIRE:

- A. Never leave surface units unattended at high settings. Boilovers cause smoking and greasy spillovers that may ignite. Heat oils slowly on low or medium settings.
- B. Always turn hood ON when cooking at high heat or when flambéing food (i.e. Crepes Suzette, Cherries Jubilee, Peppercorn Beef Flambé).
- C. Clean ventilating fans frequently. Grease should not be allowed to accumulate on fan or filter.
- D. Use proper pan size. Always use cookware appropriate for the size of the surface element.

⚠WARNING: TO REDUCE THE RISK OF FIRE, ELECTRIC SHOCK OR INJURY TO PERSONS, OBSERVE THE FOLLOWING:

- A. Installation work and electrical wiring must be done by qualified person(s) in accordance with all applicable codes and standards, including fire-related construction.
- B. Sufficient air is needed for proper combustion and exhausting of gases through the flue (chimney) of fuel burning equipment to prevent back drafting. Follow the heating equipment manufacturer's guideline and safety standards such as those published by the National Fire Protection Association (NFPA), and the American Society for Heating, Refrigeration and Air Conditioning Engineers (ASHRAE), and the local code authorities. When applicable, install any makeup (replacement) air system in accordance with local building code requirements. Visit GEAppliances.com for available makeup air solutions.
- C. When cutting or drilling into wall or ceiling, do not damage electrical wiring and other hidden utilities.
- D. Ducted fans must always be vented to the outdoors.

⚠WARNING: TO REDUCE THE RISK OF FIRE, USE ONLY METAL DUCTWORK.

- Do not attempt to repair or replace any part of your hood unless it is specifically recommended in this manual. All other servicing should be referred to a qualified technician.

READ AND SAVE THESE INSTRUCTIONS.

INSTRUCTIONS DE SÉCURITÉ IMPORTANTES

LISEZ TOUTES LES INSTRUCTIONS AVANT D'UTILISER VOTRE APPAREIL

PRÉCAUTIONS EN MATIÈRE DE SÉCURITÉ

⚠ AVERTISSEMENT : POUR RÉDUIRE LE RISQUE D'INCENDIE, DE SECOURS ÉLECTRIQUE OU DE BLESSURE CORPORELLE, OBSERVEZ LES PRÉCAUTIONS SUIVANTES :

- A. N'utilisez cet appareil que de la manière prévue par le fabricant. Si vous avez des questions, appelez le fabricant.
- B. Avant de réparer ou de nettoyer votre appareil, débranchez le courant au niveau du panneau de service et verrouillez les mécanismes de débranchement de service pour éviter tout branchement accidentel au courant. Si vous ne pouvez pas verrouiller les mécanismes de débranchement de service, attachez soigneusement un avertissement bien visible, comme une étiquette, au panneau de service.
- C. N'utilisez jamais cet appareil avec un mécanisme de réglage de la vitesse à semi-conducteurs.
- D. Cet appareil doit être bien mis à la terre.

⚠ ATTENTION : UNIQUEMENT À USAGE DE VENTILATION GÉNÉRALE. N'UTILISEZ JAMAIS POUR L'ÉCHAPPEMENT DE MATIÈRES ET DE VAPEURS EXPLOSIVES.

⚠ AVERTISSEMENT : POUR RÉDUIRE LE RISQUE DE BLESSURE CORPORELLE SI DE LA GRAISSE PREND FEU SUR LA SURFACE DE CUISSON DU FOUR, SUIVEZ LES INSTRUCTIONS SUIVANTES* :

- A. ÉTOUFFEZ LES FLAMMES avec un couvercle qui convient, une tôle à biscuits ou un plateau en métal, puis éteignez le brûleur. FAITES BIEN ATTENTION DE NE PAS VOUS BRÛLER. Si les flammes ne s'éteignent pas immédiatement, SORTEZ ET APPELEZ LES POMPIERS.
- B. NE DÉPLACEZ JAMAIS UNE CASSEROLLE QUI FLAMBE— Vous pouvez vous brûler.
- C. N'UTILISEZ JAMAIS D'EAU, en particulier de serviette ou de chiffon mouillé—il se produira une explosion violente de vapeur brûlante.
- D. N'UTILISEZ UN EXTINCTEUR que si :
 1. Vous avez un extincteur de classe ABC et vous savez comment l'utiliser;
 2. Le feu est réduit et confiné à l'endroit où il a commencé;
 3. Vous avez déjà appelé les pompiers;
 4. Vous combattez les flammes en tournant le dos à une sortie.

* Basé sur l'ouvrage intitulé «Kitchen Fire Safety Tips» publié par la NFPA.

⚠ AVERTISSEMENT : RÉDUISEZ LE RISQUE D'UN FEU DE GRAISSE SUR LA SURFACE DE CUISSON DU FOUR :

- A. Ne laissez jamais sans surveillance les unités de cuisson de surface à une température élevée. Le bouillonnement occasionne des débordements fumants et grasseux qui peuvent prendre feu. Chauffez à feu doux les substances huileuses, avec un réglage bas ou moyen.
- B. Mettez toujours la hotte en marche quand vous cuisinez à haute température ou quand vous faites flamber des aliments (p. ex. crêpes Suzette, cerises Jubilee, Boeuf flambé Peppercorn).
- C. Nettoyez les mécanismes de ventilation fréquemment. Il ne faut pas permettre une accumulation de graisse sur le ventilateur ou sur le filtre.
- D. Utilisez une casserole de bonne taille. Utilisez toujours un ustensile de cuisine qui convienne au diamètre de l'élément de cuisson.

⚠ AVERTISSEMENT : POUR RÉDUIRE LE RISQUE D'INCENDIE, DE SECOURS ÉLECTRIQUE OU DE BLESSURE CORPORELLE, OBSERVEZ LES PRÉCAUTIONS SUIVANTES :

- A. Vous devez faire exécuter tous les travaux d'installation et de câblage électrique par une personne qualifiée, conformément à tous les codes et les normes en vigueur, en particulier ceux de construction relatifs aux incendies.
- B. Vous devez assez d'air pour avoir une bonne combustion et permettre l'évacuation des gaz par le conduit de cheminée du matériel de combustion du carburant, afin d'éviter tout retour d'air. Suivez les directives du fabricant de matériel de combustion et les normes de sécurité comme celles publiées par la National Fire Protection Association (NFPA) et l'American Society for Heating, Refrigeration and Air Conditioning Engineers (ASHRAE), ainsi que les modalités des codes locaux. Le cas échéant, installez un système de compensation d'air (remplacement) conformément aux conditions des codes locaux du bâtiment. Visitez le site GEAppliances.com pour connaître les solutions offertes en matière de système de compensation d'air.
- C. Si vous faites un trou ou une ouverture dans un mur ou un plafond, n'endommagez pas les fils électriques et les autres installations cachées de service public.
- D. Vous devez toujours alimenter les ventilateurs dans les conduits en air en provenance de l'extérieur.

⚠ AVERTISSEMENT : POUR RÉDUIRE LE RISQUE D'INCENDIE, N'UTILISEZ QUE DES CONDUITS EN MÉTAL.

- N'essayez jamais de remplacer ou de réparer un élément de votre hotte si le présent manuel ne le recommande pas expressément. Tout autre entretien doit être effectué par un technicien qualifié.

LISEZ ET CONSERVEZ CES INSTRUCTIONS.

Controls

1. **Light control**

Turn the light control from OFF to HI for the brightest light while cooking.

2. **Fan control**

Turn the fan control speed from OFF to HI as needed.

Continuous use of the fan system while cooking helps keep the kitchen comfortable and less humid. It also reduces cooking odors and soiling moisture that create a frequent need for cleaning.

NOTE: When the fan is operating on the lowest setting, it will be very quiet. Always make sure that the fan is turned OFF when you are finished in the kitchen.

3. **Fan ON indicator light**

Comes on when the fan is turned on.

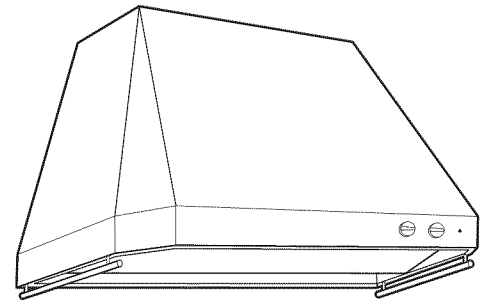

Appearance will vary.

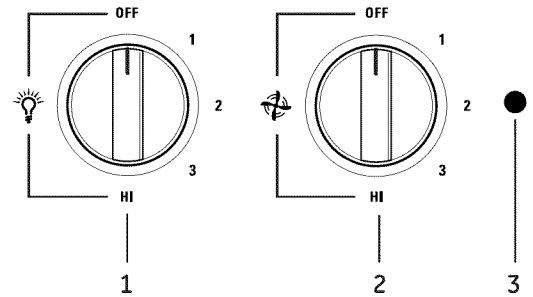

Implement holders

Implement holder rods are located on each side of the hood.

Use these rods to hang and display cooking utensils such as whisks, spoons, forks or any non-flammable decorative items. Frequently used small pots and pans can also hang from these rods.

⚠️WARNING:

DO NOT hang flammable items from these implement rods.

DO NOT hang items weighing more than 10 pounds on either side, or 20 pounds total weight.

⚠️AVERTISSEMENT :

N'accrochez pas d'articles inflammables à ces tringles.

N'accrochez pas d'articles pesant plus de 5 kg (10 lbs) de chaque côté, soit au total pesant plus de 10 kg (20 lbs).

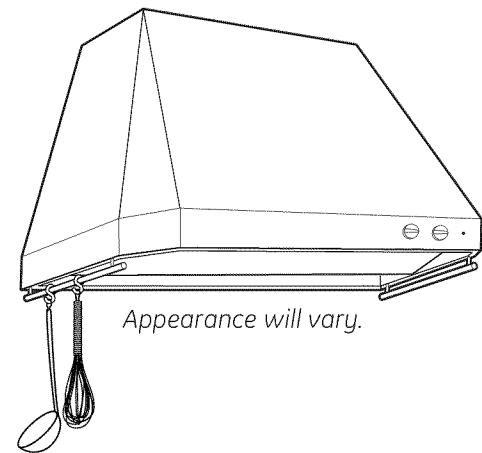

Appearance will vary.

For your safety

Pour votre sécurité

Before servicing or cleaning unit, switch power off at service panel and lock the service disconnecting means to prevent power from being switched on accidentally. When the service disconnecting means cannot be locked, securely fasten a prominent warning device, such as a tag, to the service panel.

Avant de réparer ou de nettoyer votre appareil, débranchez le courant au niveau du panneau de service et verrouillez les mécanismes de débranchement de service pour éviter tout branchement accidentel au courant. Si vous ne pouvez pas verrouiller les mécanismes de débranchement de service, attachez soigneusement un avertissement bien visible, comme une étiquette, au panneau de service.

Light bulbs

The bulbs are located on the underside of the hood.

To change the light bulbs:

1. Remove the trim ring by turning it counterclockwise.
2. Grasp the bulb on the edges and remove by turning it counterclockwise.
3. Replace with the same type and size bulb.

These 120 volt, 50 watt, par 16 halogen flood bulbs, with standard base, are available at specialty lighting stores.

These bulbs can also be ordered from your GE supplier.

Order bulb no. **WB08X10028**.

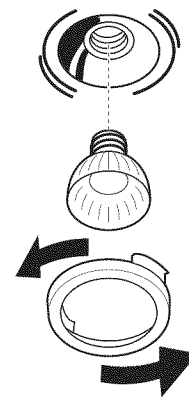

Baffle grease filters and drip trays

Island hood models have reusable metal grease baffles and drip trays.

The metal baffles channel grease released by foods on the cooktop into the drip trays. The baffles also help prevent flaming foods on the cooktop from damaging the inside of the hood.

For this reason, the baffles must **ALWAYS** be in place when the hood is used. The grease baffles and drip trays should be cleaned once a month, or as needed.

To clean the grease baffles and drip trays, drain and wipe all excess grease with a dry paper towel. Soak them and then swish them around in hot water and detergent. Don't use ammonia or ammonia products because they will darken the metal. Do not use abrasives or oven cleaners. Rinse, shake and let them dry before replacing. **They may also be cleaned in an automatic dishwasher.**

To remove:

Grasp both baffle knobs on each filter and pull them up, forward and out. Grasp the drip tray and carefully lift it up and out of the hood track.

To replace the drip trays:

1. Place and seat the drip tray into the hood track.
2. Slide them left or right until all trays are side-by-side in place in the track.

To replace the baffles:

1. Hold the baffle at the bottom by one of the knobs.
2. Place the other end of the baffle against the inside front of the hood.
3. Slide it up and push the bottom end back until it firmly seats into place.

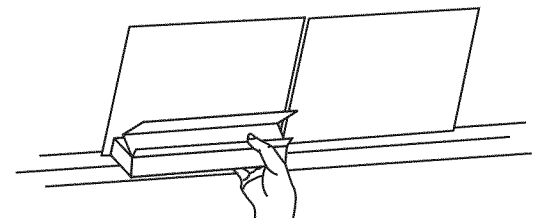
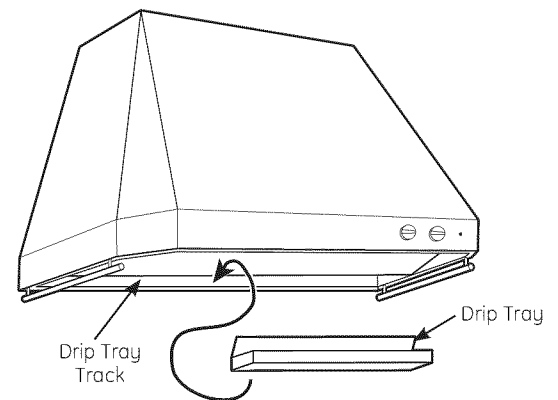

Drip Tray Replacement

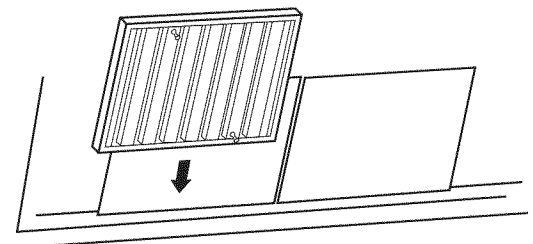
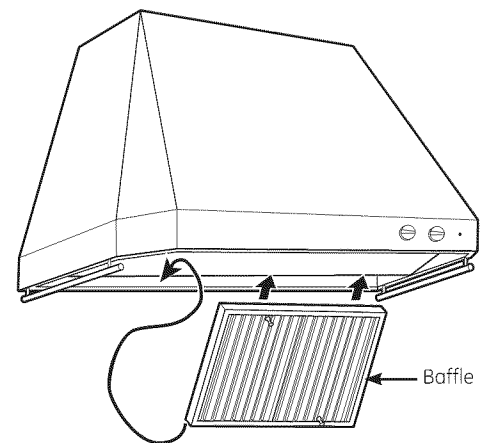

Baffle Replacement

Stainless steel surfaces

Do not use a steel wool pad; it will scratch the surface.

To clean the stainless steel surface, use warm sudsy water or a stainless steel cleaner or polish. Always wipe the surface in the direction of the grain. Follow the cleaner instructions for cleaning the stainless steel surface.

To inquire about purchasing stainless steel appliance cleaner or polish, or to find the location of a dealer nearest you, please call our toll-free number:

National Parts Center 1.800.626.2002
GEApplianceParts.com

Questions?

Use this
problem
solver!

PROBLEM	POSSIBLE CAUSE
<p>FAN AND LIGHTS DO NOT OPERATE WHEN THE SWITCHES ARE TURNED ON</p>	<ul style="list-style-type: none"> • The hood was never electrically connected by the installer/ electrician/builder. Call the electrician/installer/builder to complete the installation. This is not covered by warranty. • A fuse may be blown or a circuit breaker tripped. Replace the fuse or reset the circuit breaker.
<p>THE BLOWER DOES NOT WORK BUT THE LIGHTS DO</p>	<ul style="list-style-type: none"> • The blower motor wire harness was not connected or was not connected properly by the installer/electrician/builder to its mating connector located inside the hood on the top surface, to the left of the blower assembly. <ol style="list-style-type: none"> 1. Switch power off at service panel and lock the service disconnecting means to prevent power from being switched on accidentally. When the service disconnecting means cannot be locked, securely fasten a prominent warning device, such as a tag, to the service panel. 2. Remove the filters and locate the blower wire harness connector. Is it plugged into its mating connector? 3. If no, plug the blower motor connector into its mating connector on the top of the hood. Switch the power back on. Check to see if the fan now works. 4. If no, check the circuit breaker/fuse. If it is blown/tripped, replace/ reset it. Does the blower work now? If no, call GE for service.
<p>THE BLOWER FAILS TO EXHAUST THE SMOKE/STEAM/ ODORS ADEQUATELY</p>	<ul style="list-style-type: none"> • Many factors could be the root cause for reduced air-flow. <ol style="list-style-type: none"> 1. Installation could be the problem: Your hood was designed to meet specific ducting requirements. Refer to the Installation Instructions or if you do not have them, go to GEAppliances.com. If your duct length exceeds the manufacturer’s requirements, hood performance will suffer. Air-flow will also be reduced if the house duct work is too small or there are too many elbows in the system. Contact your installer or builder. 2. Obstruction in duct work could be the problem: Make sure nothing is blocking the vent (bird nests or kinks in the duct work). 3. Damper blade may not be opening. Make sure the tape is removed from the damper blades and that it swings open freely. 4. Damper blade on Wall or Roof Cap may not be opening. Contact your builder so they can make sure the damper swings open freely. 5. Dirty filters/baffles—make sure filters (and all hood surfaces) are kept clean of grease and dirt. 6. Sufficient makeup (replacement) air is required for exhausting appliances to operate to rating. Check with local building codes, which may require or strongly advise the use of makeup air.” Visit GEAppliances.com for available makeup air solutions.

The Problem Solver

Professional Island Range Hood

Questions?

*Use this
problem
solver!*

PROBLEM	POSSIBLE CAUSE
PART IS MISSING/ DAMAGED/ DEFECTIVE	<ul style="list-style-type: none">• In the unlikely event that a part would be missing, damaged or defective, we can serve you, the consumer, quickly by mailing these parts to you. We have identified several easy-to-install parts. These include: lamps, lamp bezels, baffle filters, grease trays, knobs, utensil rods, Owner's Manual and Installation Instructions. Call GE service and carefully describe your model number and the part you need. The model number is located inside the hood chassis, behind the baffle filter.
DUCT COVER IS MISSING	<ul style="list-style-type: none">• Chimney kit and duct covers for 8' ceiling installations are included with the hood. For 9' and 10' ceilings, please order the following appropriate kit:<ul style="list-style-type: none">— 42" models, ZX42DC10— 54" models, ZX54DC10Call GE Parts. See <i>Consumer Service</i> page in this manual for a list of phone numbers.
INSTALLATION PART IS MISSING/ DAMAGED/ DEFECTIVE	<ul style="list-style-type: none">• We provide a 10" round, vertical duct transition. This part can be mailed out to the hood installer if it is in some way unusable. All other duct transitions, elbows, etc. must be purchased locally. We can also mail out many other parts that come with the hood to your installer. Call GE Service. See <i>Consumer Service</i> page in this manual for a list of phone numbers. Ask them to mail the parts only—no service call required.

With the purchase of your new Monogram appliance, receive the assurance that if you ever need information or assistance from GE, we'll be there. All you have to do is call—toll-free!

GE Answer Center®

800.626.2000

Whatever your question about any Monogram major appliance, GE Answer Center® information service is available to help. Your call—and your question—will be answered promptly and courteously. And you can call any time. GE Answer Center® service is open 24 hours a day, Monday through Saturday.

OR

Visit our Website at: monogram.com

Monogram Preferred Service

800.444.1845

If your Monogram appliance should ever require service, you can depend on Monogram Preferred Service. Simply call 800.444.1845, where our Monogram Preferred Service Specialists are available 7 a.m.–10 p.m. ET Monday through Friday and 8 a.m.–6 p.m. ET Saturday and Sunday to coordinate your service appointment.

For Customers With Special Needs...

800.626.2000

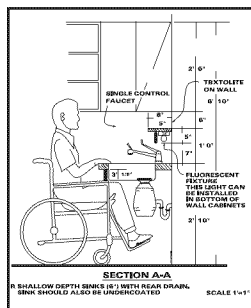

GE offers, free of charge, a brochure to assist in planning a barrier-free kitchen for persons with limited mobility.

Consumers with impaired hearing or speech who have access to a TDD or a conventional teletypewriter may call 800.TDD.GEAC (800.833.4322) to request information or service.

Service Contracts

800.626.2224

You can have the secure feeling that GE Consumer Service will still be there after your warranty expires. Purchase a GE contract while your warranty is still in effect and you'll receive a substantial discount. With a multiple-year contract, you're assured of future service at today's prices.

Parts and Accessories

800.626.2002

Individuals qualified to service their own appliances can have parts or accessories sent directly to their home. The GE parts system provides access to over 47,000 parts...and all GE Genuine Renewal Parts are fully warranted. VISA, MasterCard and Discover cards are accepted.

User maintenance instructions contained in this manual cover procedures intended to be performed by any user. Other servicing generally should be referred to qualified service personnel. Caution must be exercised, since improper servicing may cause unsafe operation.

YOUR MONOGRAM HOOD WARRANTY

Staple sales slip or cancelled check here. Proof of original purchase date is needed to obtain service under warranty.

WHAT IS COVERED

LIMITED ONE-YEAR WARRANTY

For one year from date of original purchase, we will provide, free of charge, parts and service labor in your home to repair or replace **any part of the hood** that fails because of a manufacturing defect.

.....

This warranty is extended to the original purchaser and any succeeding owner for products purchased for ordinary home use in the 48 mainland states, Hawaii and Washington, D.C. If the product is located in an area where service by a GE Authorized Servicer is not available, you may be responsible for a trip charge or you may be required to bring the product to an Authorized GE Service Location for service. In Alaska the warranty is the same except that it is LIMITED because you must pay to ship the product to the service shop or for the service technician's travel costs to your home.

All warranty service will be provided by our Factory Service Centers or by our authorized Customer Care® servicers during normal working hours.

Should your appliance need service, during warranty period or beyond, call 800.444.1845. Please have serial number and model number available when calling for service.

WHAT IS NOT COVERED

- Service trips to your home to teach you how to use the product.
- Replacement of house fuses or resetting of circuit breakers.
- Incidental or consequential damage caused by possible defects with this appliance.
- Replacement of the filters.
- Damage to the product caused by accident, fire, floods or acts of God.
- Failure of the product if it is used for other than its intended purpose or used commercially.
- Improper installation, delivery or maintenance.
- Damage caused after delivery.
- Product not accessible to provide required service.
- Installation or service for a makeup (replacement) air system.

EXCLUSION OF IMPLIED WARRANTIES—Your sole and exclusive remedy is product repair as provided in this Limited Warranty. Any implied warranties, including the implied warranties of merchantability or fitness for a particular purpose, are limited to one year or the shortest period allowed by law.

Some states do not allow the exclusion or limitation of incidental or consequential damages, so the above limitation or exclusion may not apply to you. This warranty gives you specific legal rights, and you may also have other rights which vary from state to state.

To know what your legal rights are in your state, consult your local or state consumer affairs office or your state's Attorney General.

**Warrantor: General Electric Company,
Louisville, KY 40225**



GE Appliances & Lighting
Appliances
General Electric Company
Louisville, KY 40225
GEAppliances.com