

# ELECTRIC COOKTOP INSTALLATION INSTRUCTIONS

INSTALLATION AND SERVICE MUST BE PERFORMED BY A QUALIFIED INSTALLER.

**IMPORTANT: SAVE FOR LOCAL ELECTRICAL INSPECTOR'S USE.  
READ AND SAVE THESE INSTRUCTIONS FOR FUTURE REFERENCE.**

U.S.A.



**⚠ WARNING** FOR YOUR SAFETY: DO NOT store or use gasoline or other flammable vapors and liquids in the vicinity of this or any other appliance.

## PRODUCT DIMENSIONS

### IMPORTANT INSTALLATION INFORMATION

- All electric cooktops run off a single phase, three-wire or four-wire cable, 124/240 volt or 120/208 volt, 60 hertz, AC only electrical supply with ground.
- Please note minimum distance between cooktop and adjacent and overhead unprotected cabinetry is 30" (76.2 cm).

**⚠ WARNING** The corners of this unit are fragile. Carefully install the cooktop by its sides. When installing, never let the weight of the unit rest on any one corner.

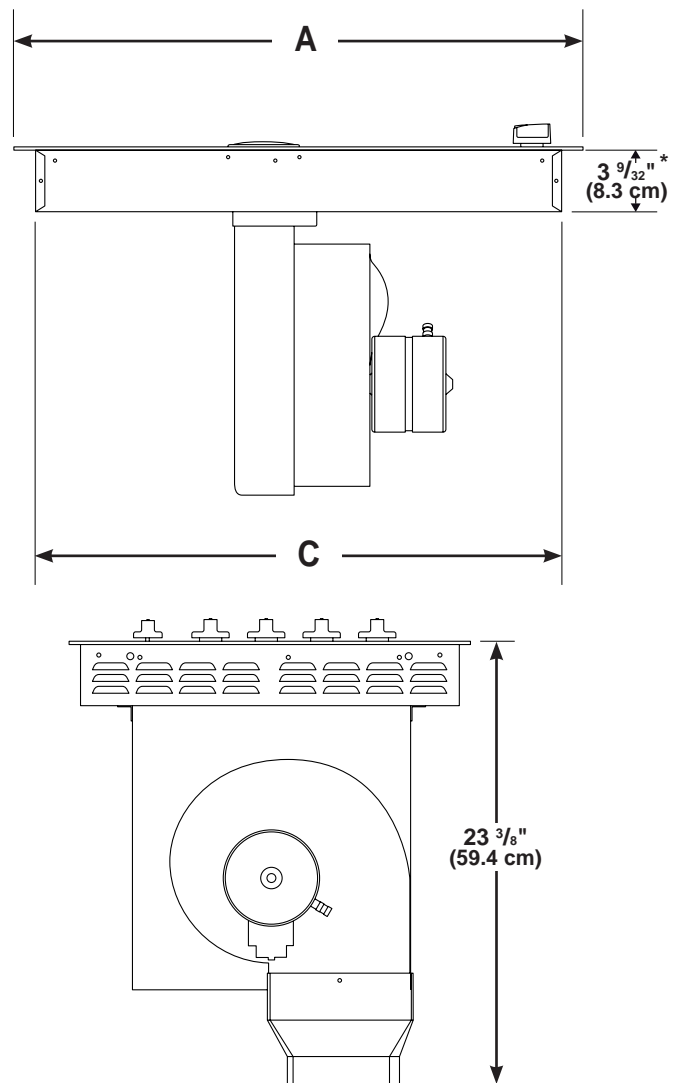
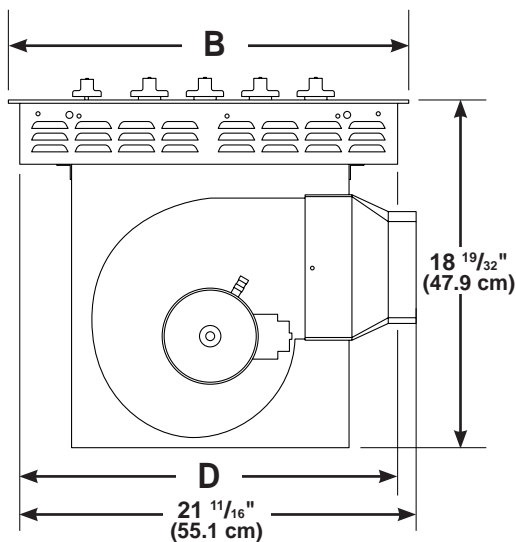

Figure 1 - PRODUCT DIMENSIONS

PRODUCT DIMENSIONS				
MODEL	A. GLASSTOP WIDTH	B. COOKTOP DEPTH	C. CHASSIS WIDTH	D. CHASSIS DEPTH
30" Cooktop	30 3/4" (78.1 cm)	22 1/16" (56.0 cm)	28 19/32" (72.6 cm)	20 27/32" (52.9 cm)
36" Cooktop	36 3/4" (93.4 cm)	22 1/16" (56.0 cm)	34 7/32" (86.9 cm)	20 27/32" (52.9 cm)

All dimensions are in inches (cm).

\* Allow 7" (17.8 cm) space below cooktop to clear the electric cable and allow for installation of the junction box on the wall at the back of the cooktop.

P/N 318205430 (1304) Rev. A

Printed in U.S.A.

# ELECTRIC COOKTOP INSTALLATION INSTRUCTIONS

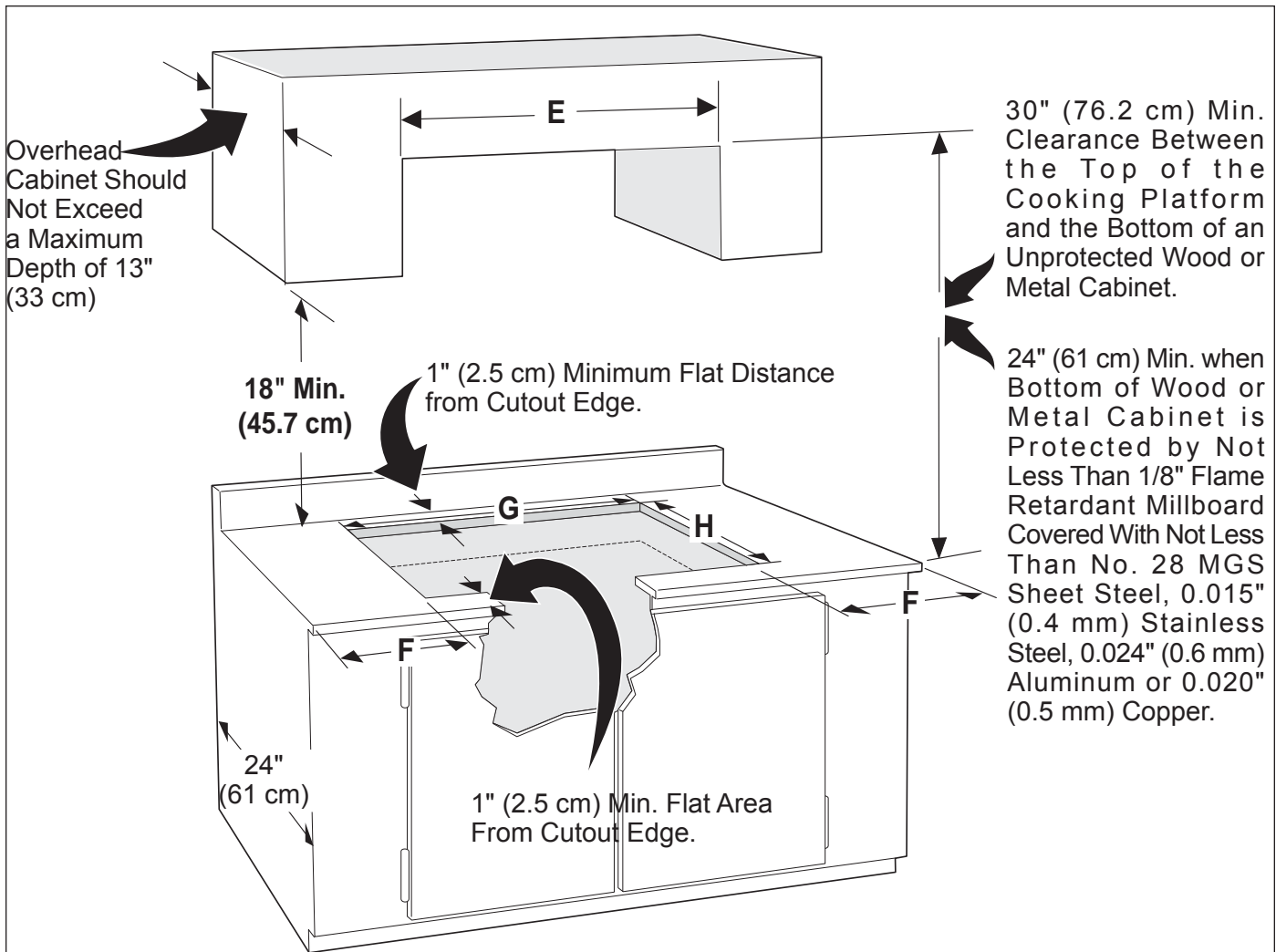

Figure 2 – CABINET DESIGN

MODEL	E. Top Cabinet Minimum Side Clearance	F. Minimum Clearance from Each Side	G. Cutout Width	H. Cutout Depth
			Tolerance -0" +1/8" (0.3cm)	Tolerance -0" +1/8" (0.3cm)
30" Cooktop	30" (76.2 cm)	9" (22.9 cm)	28 7/8" (73.3 cm)	21 1/8" (53.7 cm)
36" Cooktop	36" (91.4 cm)	9" (22.9 cm)	34 1/2" (87.6 cm)	21 1/8" (53.7 cm)

**CAUTION** To eliminate the risk of burns or fire from reaching over heated surfaces, cabinet storage space located above the cooktop should be avoided. If cabinet storage is to be provided, the risk can be reduced by installing a range hood that projects horizontally a minimum of 5 inches beyond the bottom of the cabinets.

# ELECTRIC COOKTOP INSTALLATION INSTRUCTIONS

## Important Notes to the Installer

1. Read all instructions contained in these installation instructions before installing the cooktop.
2. Remove all packing material before connecting the electrical supply to the cooktop.
3. Observe all governing codes and ordinances.
4. Be sure to leave these instructions with the consumer.

## Important Note to the Consumer

Keep these instructions with your Use and Care Guide for future reference.

## IMPORTANT SAFETY INSTRUCTIONS

- Be sure your cooktop is installed and grounded properly by a qualified installer or service technician.
- These cooktops must be electrically grounded in accordance with local codes or, in their absence, with the National Electrical Code ANSI/NFPA No. 70—latest edition in the United States.

**⚠ WARNING** The electrical power to the cooktop must be shut off while line connections are being made. Failure to do so could result in serious injury or death.

## Electrical Requirements

Observe all governing codes and local ordinances.

1. A 3-wire or 4-wire single phase 120/240 or 120/208 Volt, 60 Hz AC only electrical supply is required on a separate circuit fused on both sides of the line. A 50A minimum time-delay fuse or circuit breaker is needed. DO NOT fuse neutral.

**NOTE:** Wire sizes and connections must conform with the fuse size and rating of the appliance in accordance with the National Electrical Code ANSI/NFPA No. 70—latest edition.

**⚠ WARNING** An extension cord must not be used with this appliance. Such use may result in a fire, electrical shock, or other personal injury.

2. The appliance should be connected to the fused disconnect (or circuit breaker) box through flexible armored or nonmetallic sheathed cable. The flexible armored cable extending from this appliance should be connected directly to the grounded junction box. The junction box should be located as shown in Figure 4 with as much slack as possible remaining in the cable between the box and the appliance, so it can be moved if servicing

is ever necessary.

3. A suitable strain relief must be provided to attach the flexible armored cable to the junction box. **Observe all governing codes and local ordinances.**



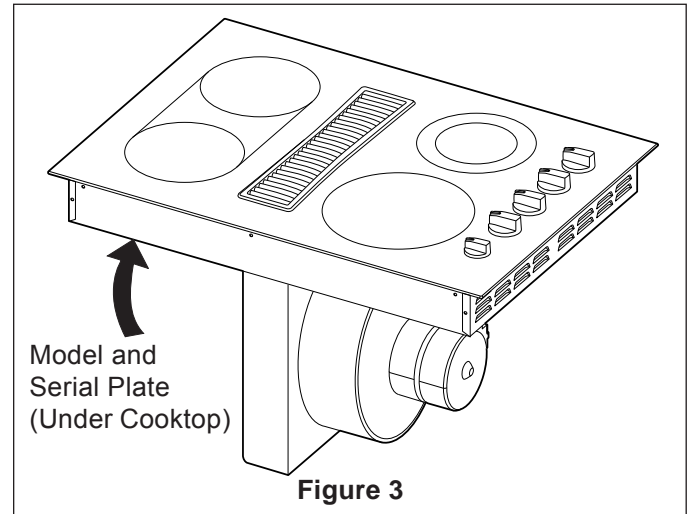



## Serial Plate Location



## Required Tools for Installation

- Phillips Screwdriver
- 1/4" Nut driver / Ratchet
- 7/16" Nut driver / Ratchet

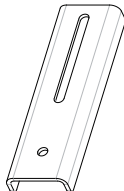
## Supplied Hardware

Qty.	Description	Used for
(4)	 1/4-20 Nylon Insert 7/16" Hex Nut	Blower (fig. 19)
(2)	 #10-24 3.5" Long Phillips Screw	Brackets (fig.15 & 16)
(4)	 #8-18 Wide Head Phillips Screw	Transition Duct (fig. 20)
(8)	 #8-18 Black 1/4" Hex Head Screw	Plenum and Wire Box (fig. 17 & 21)
(2)	 Hold Down Bracket	Countertop (fig. 15 & 16)
(4)	 Plastic Access Hole Plug	Plenum (fig. 17)

# ELECTRIC COOKTOP INSTALLATION INSTRUCTIONS

## 1 Positioning the cooktop

The exhaust vent from the cooktop must be located between wall studs or floor joists so that the ductwork may be installed properly

## 2 Prepare Base Cabinet

This cooktop is designed to fit easily into a variety of cabinets. However, some cabinets may require modifications.

### 2.1 Preparing a cabinet with drawers

If the cabinet has drawers, the drawers must be removed and the drawer fronts attached to the front of the cabinet.

### 2.2 Verify internal length and width of base cabinet

In some cabinets, the sides or back wall may need to be cut out, and the corner braces removed in order to accommodate the unit.

### 2.3 Counter top cutout

Countertops with a rolled front edge and radius at the base of the backsplash may not provide the flat surface area required to accommodate the cooktop.

Cut countertop opening according to the dimensions shown in Figure 2. The opening must be cut squarely with sides parallel to each other, front and rear perpendicular to the sides.

### 2.4 Provide Electrical Connection

Install the junction box under the cabinet within shaded area shown in Figure 4 and run 120/240 or 120/208 Volt, AC wire from the main circuit panel.

NOTE: DO NOT connect the wire to the circuit panel at this time. Wait until all wires have been connected in the junction box.

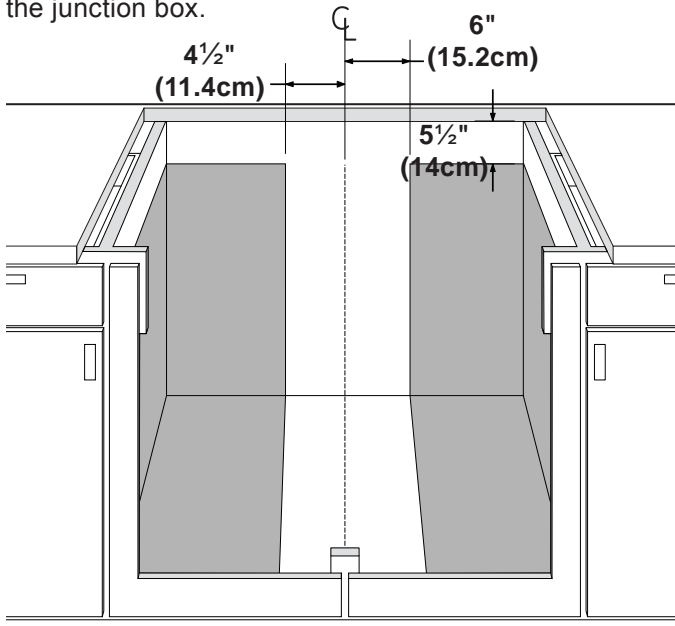

Figure 4 – ELECTRICAL OUTLET INSTALL DIMENSIONS

## 3 Preparing for Ductwork

Cut hole in cabinet wall or floor as appropriate for your installation. Make sure exhaust duct is located between wall studs or floor joists.

**⚠ WARNING** Ductwork **MUST** be vented to outside. **DO NOT** vent into a wall, ceiling, crawlspace, attic or any concealed space.

**⚠ WARNING** When cutting or drilling into wall or ceiling, **DO NOT** damage electrical wiring and other hidden utilities.

The blower can be installed to exhaust down or to the back. See Figure 5 or 6 for the location of the exhaust outlet for bottom or rear discharge.

DUCTWORK INSTALLATION DIMENSIONS	
Model	J. Right of Center
30" Model	1 13/16" (4.6 cm)
36" Model	1 3/16" (3.1 cm)

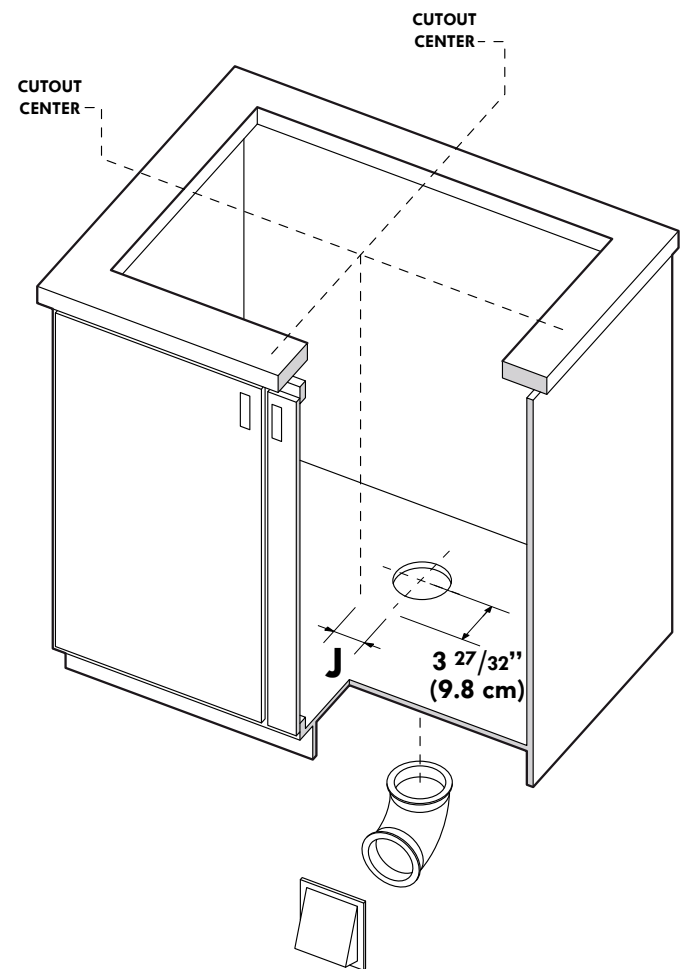

Figure 5 – BOTTOM DUCTWORK HOLE

# ELECTRIC COOKTOP INSTALLATION INSTRUCTIONS

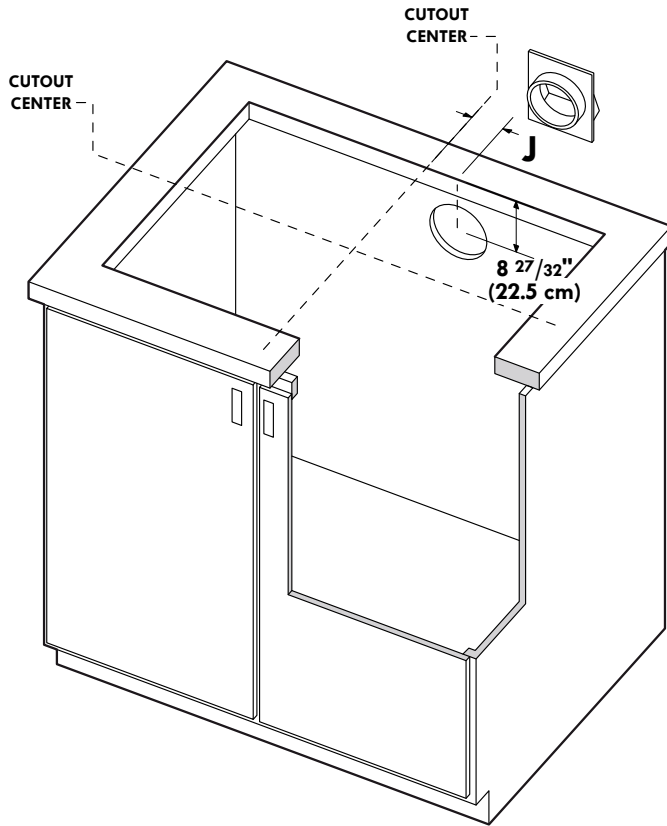

Figure 6 – BACK WALL DUCTWORK HOLE

### 3.1 Alternate Ducting

For installations involving left or right exhaust ductwork, a duct adapter kit 5304488297 is available. See Figure 6B. Dimensions are shown in Figure 6A for locating the duct cutout with this adapter kit.

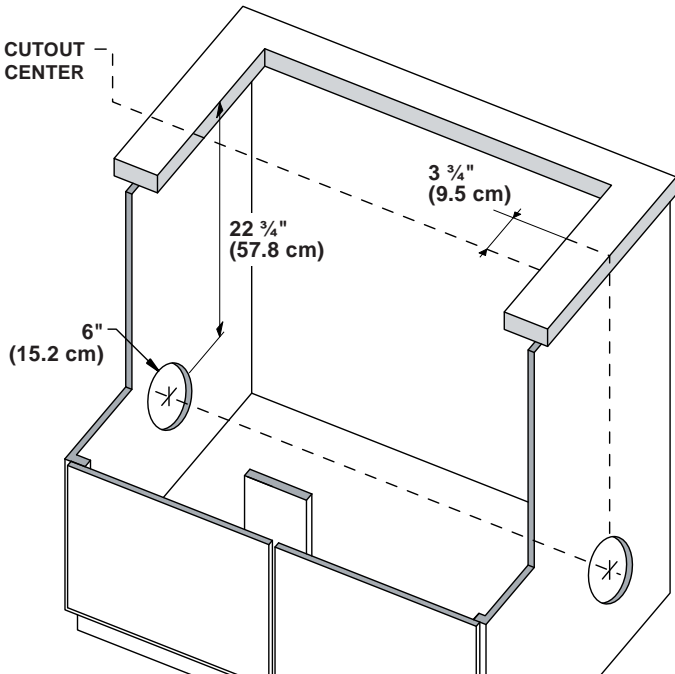
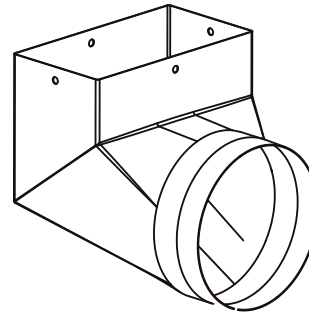

Figure 6A – ALTERNATE SIDE DUCTWORK HOLES



Kit 5304488297  
For Left or Right Ducting

Figure 6B – ALTERNATE DUCT TRANSITION KIT

### 3.2 Makeup Air

Local building codes may require the use of makeup air systems. Consult local codes to determine specific makeup air requirements for your installation.

Kit 316902492 is available to reduce airflow below 400CFM.

### 4 Blower to Ductwork Alignment

The use of flexible ducting is discouraged because it can severely restrict airflow. If the blower outlet and the floor or wall duct location DO NOT align, then flexible METAL ducting can be used to adapt to an offset.

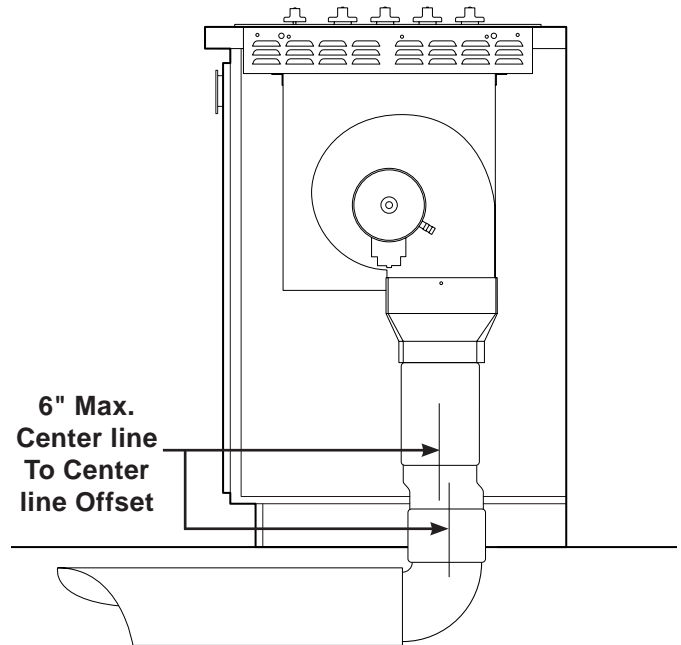

Figure 7 – DUCTWORK ALIGNMENT

# ELECTRIC COOKTOP INSTALLATION INSTRUCTIONS

## 5 Installing the Ductwork

Use galvanized or aluminum duct in 6" round or 3 1/4" x 10" size, or a combination of both. PVC duct should be used if installing under a poured concrete slab. Use the shortest and straightest duct run possible. For satisfactory performance, the duct run should not exceed 100 feet equivalent length. Refer to the "Calculating Duct Length" chart for equivalent lengths. (see page 13).

NOTE: Local building code must be followed in specifying approved type and schedule of ALL duct used. Always use an appropriate roof or wall cap with damper.

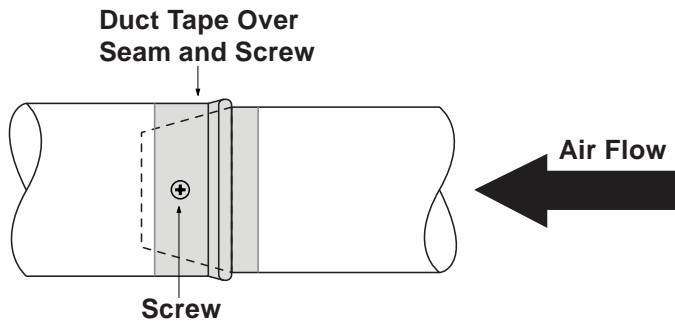

**Figure 8 – DUCT TAPE OVER SEAM AND SCREW**

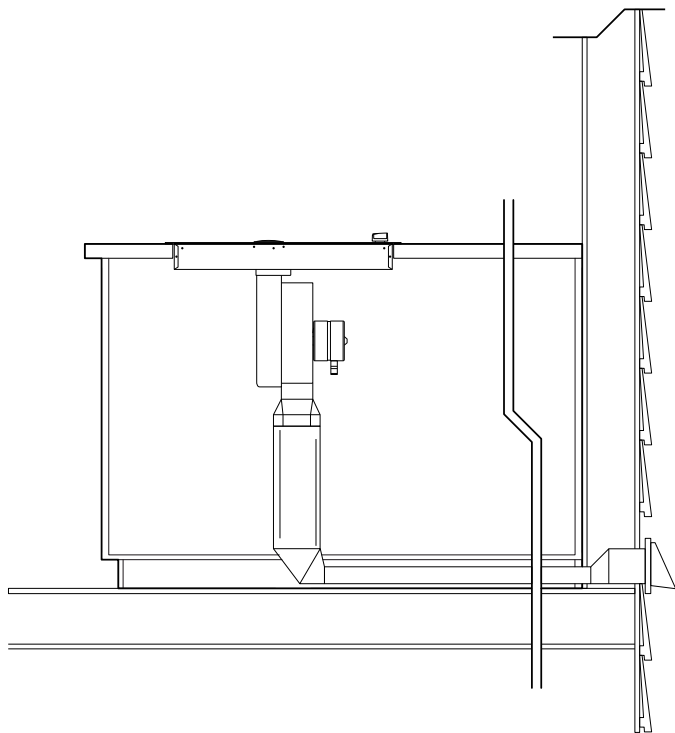

**Figure 9 – DUCT ON-THE-FLOOR**

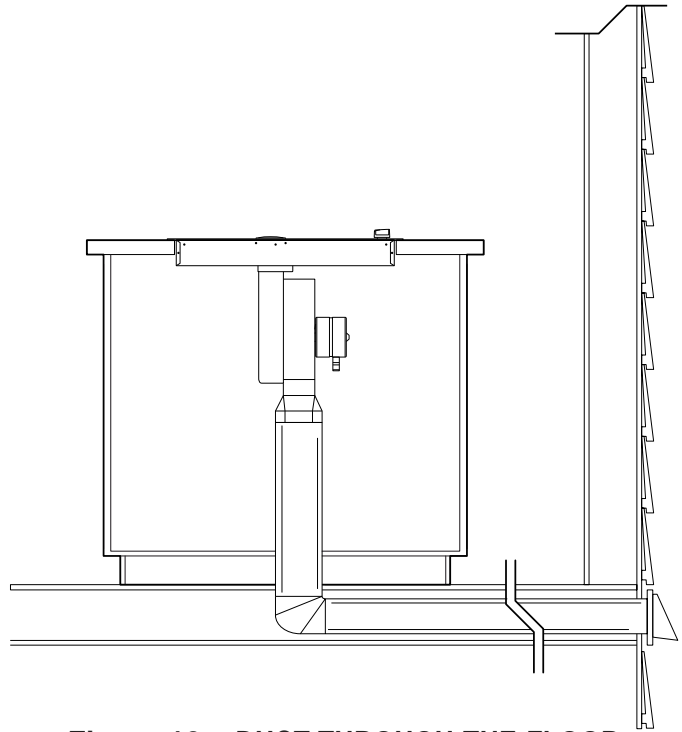

**Figure 10 – DUCT THROUGH-THE-FLOOR**

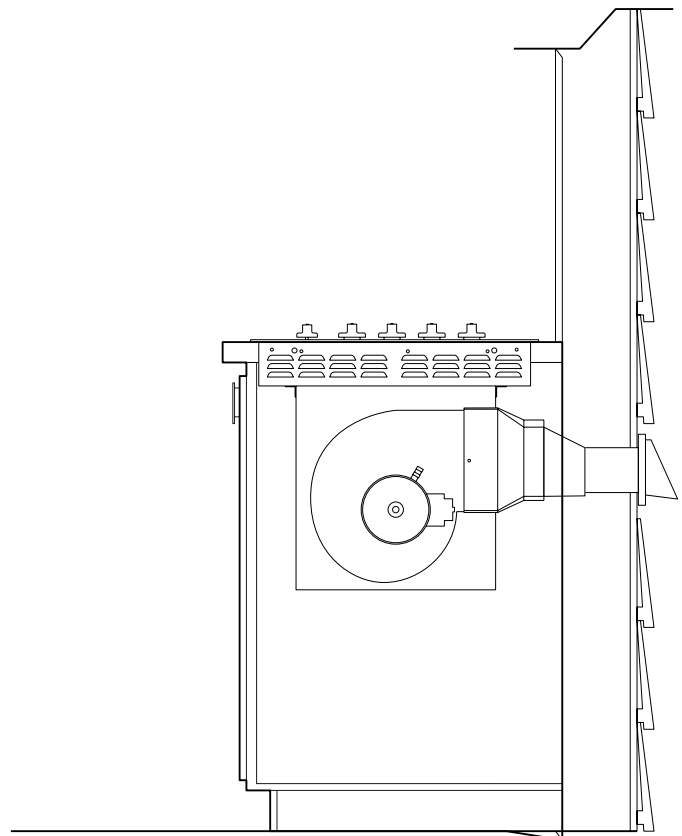

**Figure 11 – DUCT THROUGH-THE-WALL**

# ELECTRIC COOKTOP INSTALLATION INSTRUCTIONS

## 6 Installing the cooktop into countertop

Lift the cooktop by the glass side edges as shown Figure 12.

**CAUTION** DO NOT use the glass top vent opening to lift or move the cooktop into position – glass breakage may occur (Figure 13).

Lower the cooktop into the countertop opening, guiding it into position. Glass is fragile—DO NOT allow it to drop onto the countertop. Support from the underside and lower slowly. Carefully remove your fingers one corner at a time to lower the cooktop into position.

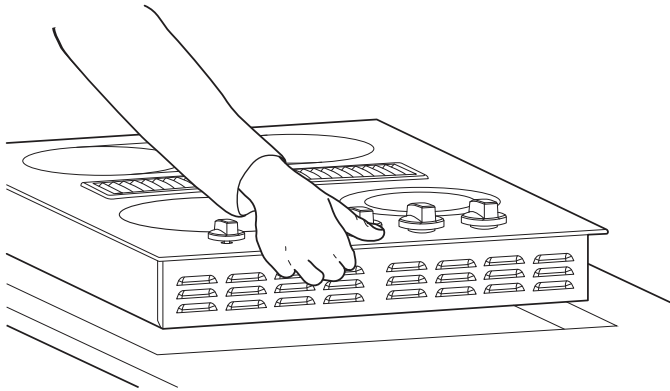

Figure 12 – HANDLE THE COOKTOP BY THE EDGES

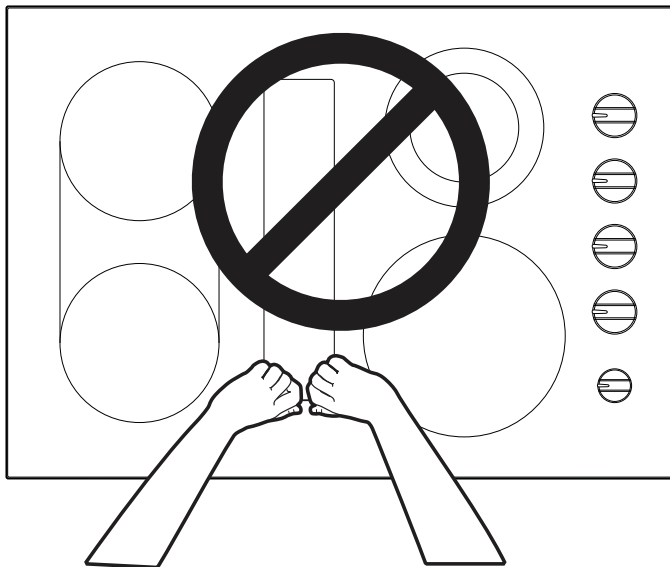

Figure 13 – DO NOT HANDLE THE COOKTOP BY THE VENT OPENING

Check for glass flatness to the countertop. Verify that the cutout is sized properly, that nothing is between the glass and the countertop, and that no parts of the burner box are binding or caught on the countertop.

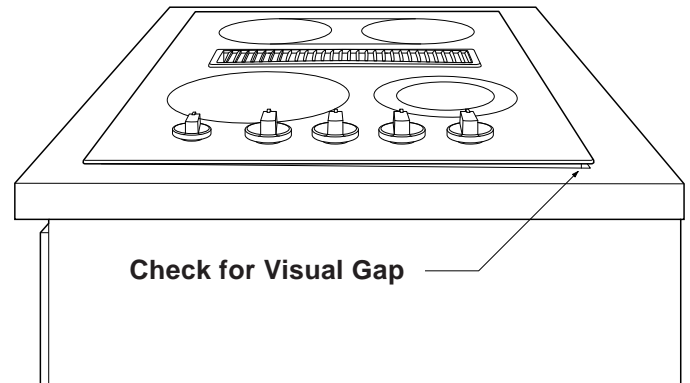

Figure 14 – CHECK FOR FLATNESS

**NOTE: DO NOT use Silicone RTV or caulk to seal the cooktop glass to the countertop.**

# ELECTRIC COOKTOP INSTALLATION INSTRUCTIONS

## 7 Installing the installation brackets

Remove the two screws in the bottom of the cooktop near the center of each of the ends. Use the two screws to attach the hold down brackets to the bottom of the cooktop. Insert the screw into the bracket until it contacts the backside of the countertop, to prevent damage to the countertop, DO NOT over tighten the screw. Figure 15 & 16.

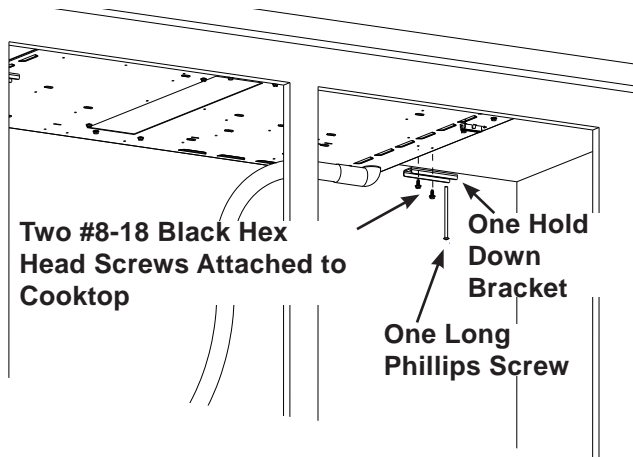

Figure 15 – ATTACH THE TWO BRACKETS

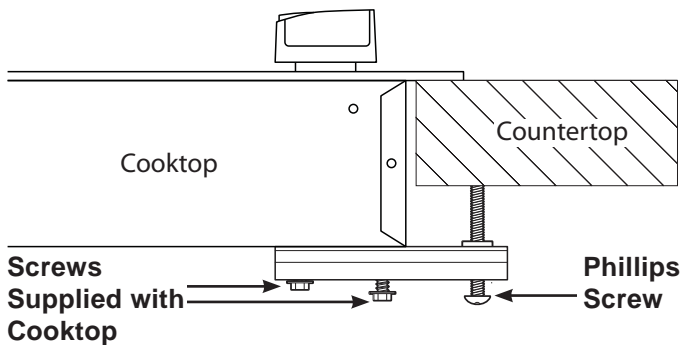

Figure 16 – SECURE COOKTOP TO COUNTERTOP

## 8 Installing the blower plenum to the cooktop

With the blower opening on the right side the plenum into the opening in the bottom of the cooktop. Push up on the plenum until the mounting rails on the sides of the plenum contact the bottom of the cooktop. Install six #8-18 hex head screws, two in each of the front and rear flanges, two in the side flange, to hold the plenum in place.

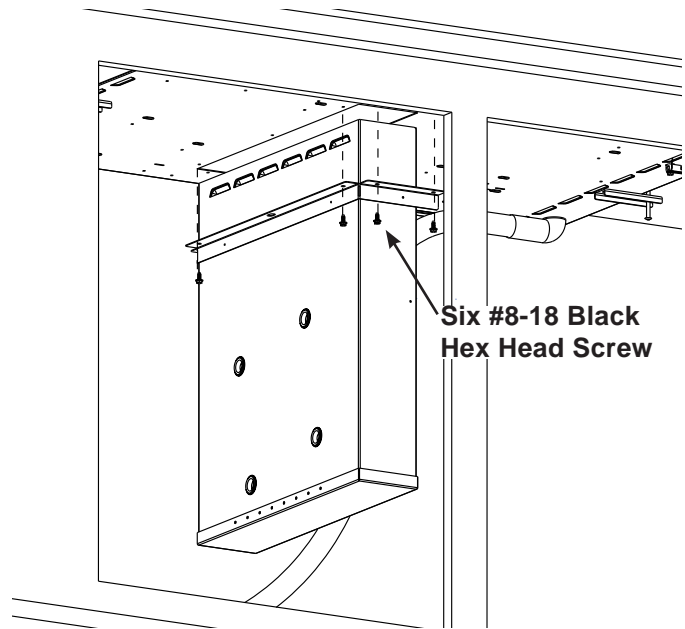

Figure 17 – ATTACH PLENUM TO THE COOKTOP



# ELECTRIC COOKTOP INSTALLATION INSTRUCTIONS

## 9 Installing the blower to the plenum

**9.1** Attach the transition to the outlet of the blower using four screws. Tape the joint to seal.

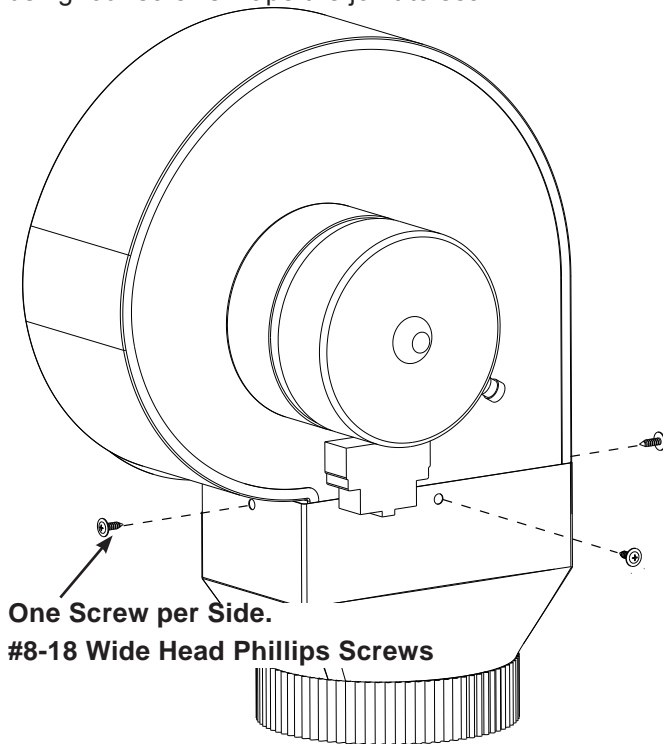

Figure 18 – ATTACH TRANSITION TO THE BLOWER

**9.2** Insert 4 plastic access hole plugs from the outside of the plenum to seal the access holes.

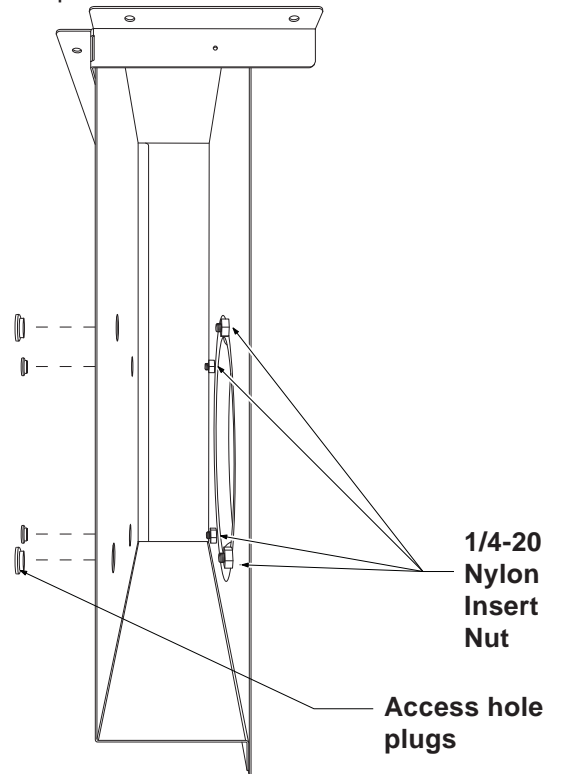

Figure 19 – NUT LOCATIONS INSIDE THE PLENUM

**9.3** Install four nylon insert nuts to the studs on the blower, finger tighten until resistance is felt. Position the blower discharge opening to match the ductwork. Slide the nuts on the side of the blower housing into the four keyhole openings on the side of the plenum and allow to slide down into the slots. Using a nut driver or ratchet through the 4 access holes in the left side of the plenum tighten the nuts.

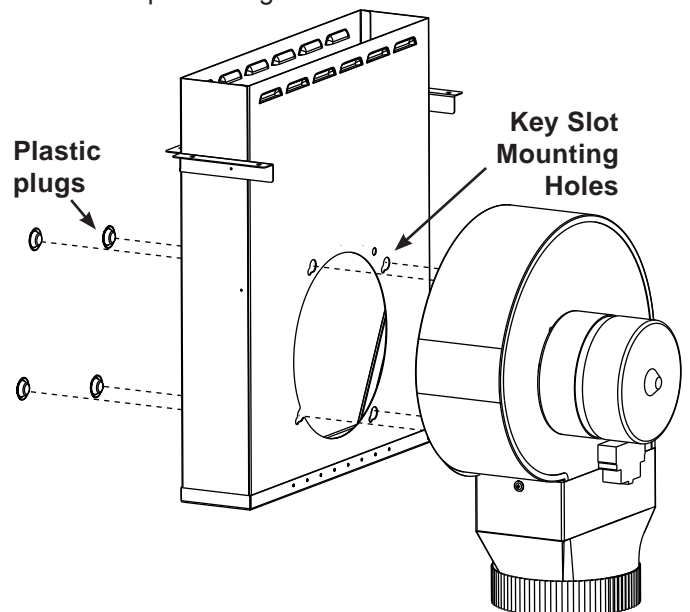

Figure 20 – ATTACH BLOWER TO THE PLENUM

# ELECTRIC COOKTOP INSTALLATION INSTRUCTIONS

## 10 Blower electrical connection

Connect the 5-pin plug on the blower assembly to the matching 5-pin receptacle on the bottom of the cooktop, making sure to engage the locking tabs on the connectors.

Fold all wires into the wire box on the end of the blower conduit. Fasten the wire box to the cooktop with two #8-18 making sure that no wires are trapped.

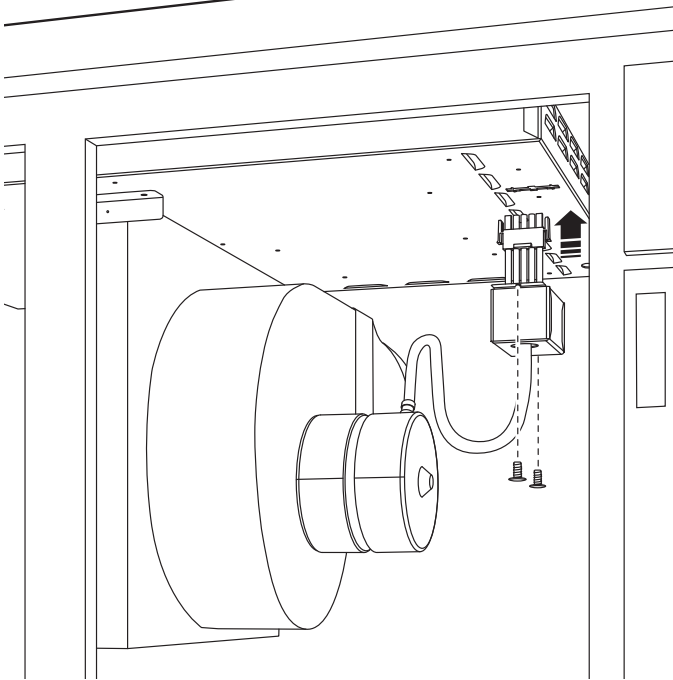

Figure 21 – CONNECT BLOWER TO COOKTOP

## 11 Connecting the ductwork

Connect the ductwork prepared in Steps 4 and 5 to the blower transition duct.

## 12 Electrical connections

**Note to Electrician:** The insulation of the power leads supplied with this appliance are UL-recognized for temperatures much higher than the temperature rating of household wiring. DO NOT replace the wires in the conduit with household wiring.

### Aluminum Wiring

**⚠ WARNING IMPROPER CONNECTION OF ALUMINUM HOUSE WIRING TO THE COPPER LEADS CAN RESULT IN SERIOUS PROBLEMS.**

Attach copper wires to aluminum wiring using special connectors designed and UL-listed for joining copper to aluminum. Follow the connector manufacturer's recommended procedure closely.

It is the responsibility and obligation of the consumer to contact a qualified installer to assure that the electrical installation is adequate and is in conformance with the National Electrical Code ANSI/NFPA No. 70-latest edition, or with CSA Standard C22.1, Canadian Electrical Code, Part 1, and local codes and ordinances.

**⚠ WARNING Risk of electrical shock (Failure to heed this warning may result in electrocution or other serious injury.)** This appliance is equipped with copper lead wire. If connection is made to aluminum house wiring, use only connectors that are approved for joining copper and aluminum wire in accordance with the National Electrical Code and local code and ordinances. When installing connectors having screws which bear directly on the steel and/or aluminum flexible conduit, do not tighten screws sufficiently to damage the flexible conduit. DO NOT over bend or excessively distort flexible conduit to avoid separation of convolutions and exposure of internal wires.

DO NOT ground to a gas supply pipe. DO NOT connect to electrical power supply until appliance is permanently grounded. Connect the ground wire before turning on the power.

# ELECTRIC COOKTOP INSTALLATION INSTRUCTIONS

**⚠ WARNING** (If your appliance is equipped with a white neutral conductor.)  
This appliance is manufactured with a white neutral power supply and a frame connected copper wire. The frame is grounded by connection of grounding lead to neutral lead at the termination of the conduit, if used in USA, in a new branch circuit installation (1996 NEC), mobile home, recreational vehicles, where local code **DO NOT** permit grounding through the neutral (white) wire or in Canada, disconnect the white and green lead from each other and use ground lead to ground unit in accordance with local codes, connect neutral lead to branch circuit-neutral conductor in usual manner see Figure 23. If your appliance is to be connected to a 3 wire grounded junction box (US only), where local code permit connecting the appliance-grounding conductor to the neutral (white) see Figure 22.

**NOTE TO ELECTRICIAN:** The armored cable leads supplied with the appliance are UL-recognized for connection to larger gauge household wiring. The insulation of the leads is rated at temperatures much higher than temperature rating of household wiring. The current carrying capacity of the conductor is governed by the temperature rating of the insulation around the wire, rather than the wire gauge alone.

Where local codes permit connecting the appliance-grounding conductor to the neutral (white) wire:

If your cooktop has a 4-wire cable to be connected to a 3-wire grounded junction box (see figure 22):

1. Disconnect the power supply.
2. In the circuit breaker, fuse box or junction box: connect appliance and power supply cable wires as shown in figure 22.

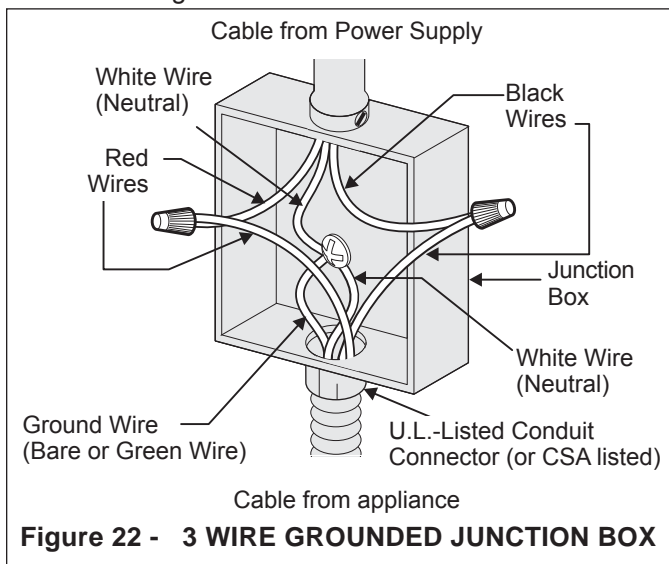

If the appliance is used in a new branch circuit installation (1996 NEC), mobile home, recreational vehicle, or where local codes **DO NOT** permit grounding through the neutral (white) wire, the appliance frame **MUST NOT** be connected to the neutral wire of the 4-wire electrical system.

If your cooktop has a 4 wire cable (see figure 23):

1. Disconnect the power supply.
2. Separate the green (or bare copper) and white appliance cable wires.
3. In the circuit breaker, fuse box or junction box: connect appliance and power supply cable wires as shown in figure 23.

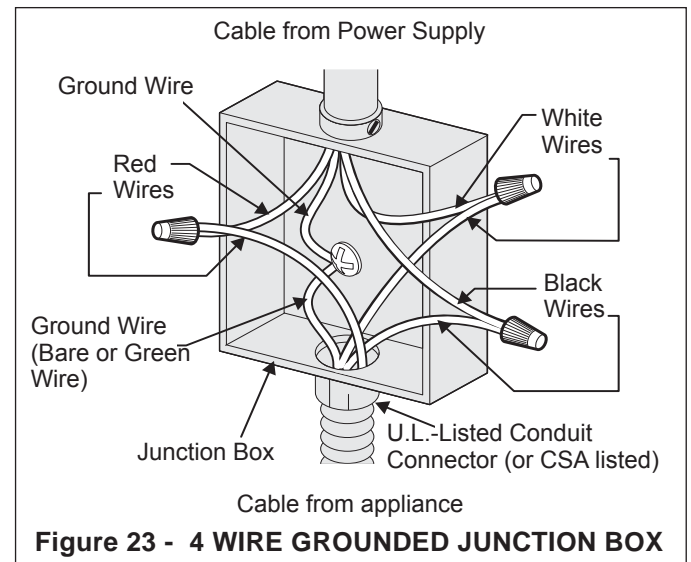

**⚠ WARNING** If connecting to a 4-wire power supply cable electrical system, the appliance frame connected ground wire **MUST NOT** be connected to the neutral wire of the 4-wire electrical system.

# ELECTRIC COOKTOP INSTALLATION INSTRUCTIONS

## 13 Install Grease Filter and Grate

DO NOT operate the vent without the grease filter in place.

- Place the grease filter diagonally through the vent opening.
- Make sure it rests, at an angle, on the supports in the vent opening.

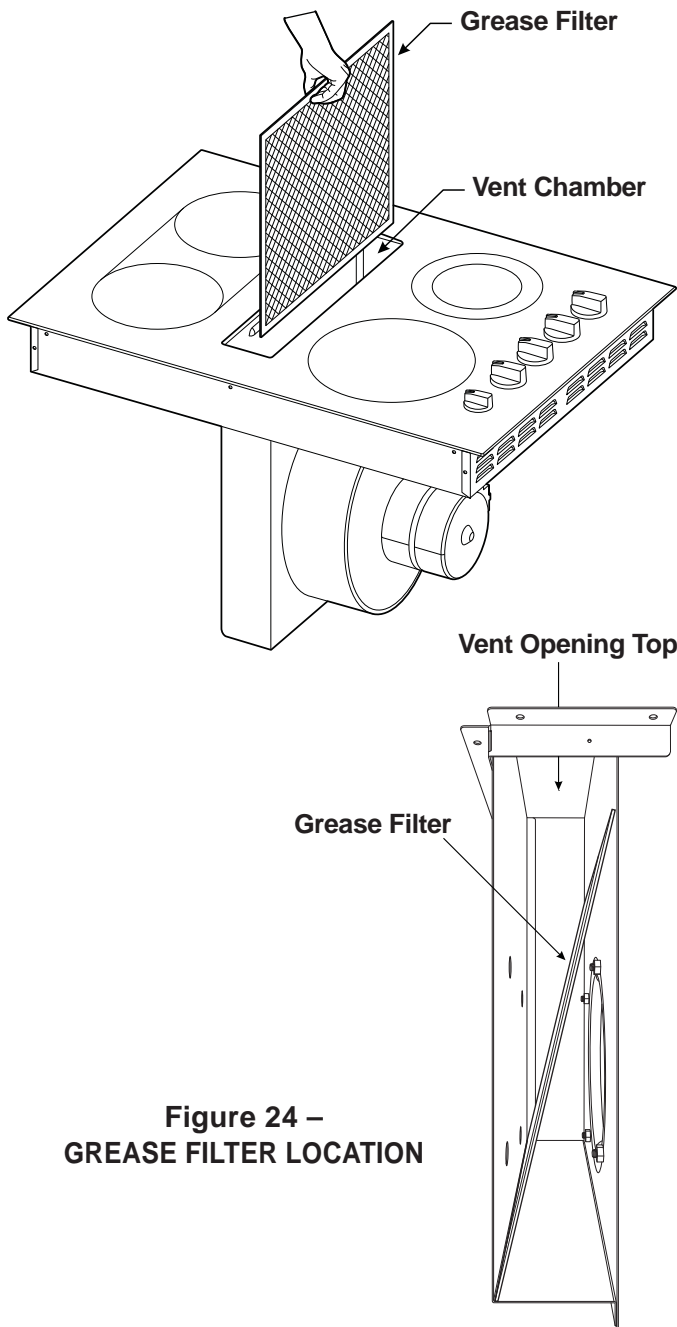

Figure 24 –  
GREASE FILTER LOCATION

- Carefully place the vent grate onto the opening. Place the side of the vent marked FRONT towards the front of the opening. The vent grate will only fit one way, DO NOT force into the opening.

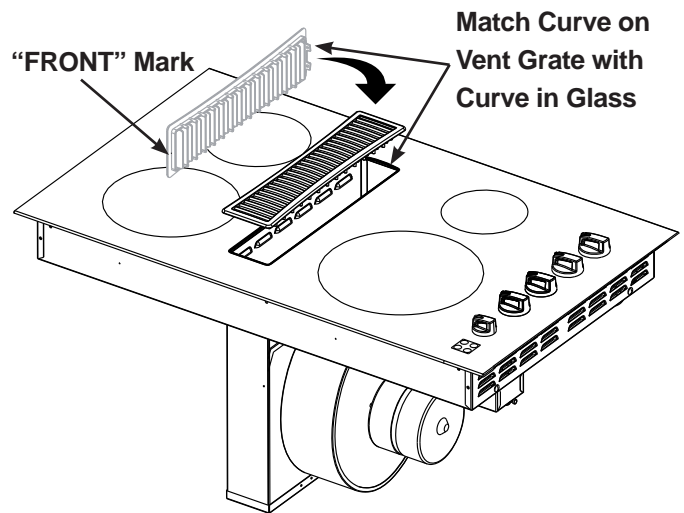

Figure 25 – INSTALL THE VENT GRATE

## Checking Operation

Refer to the **Use and Care Guide** for operation.

**CAUTION** DO NOT touch cooktop glass or elements. They may be hot enough to burn you.

## Model and Serial Number Location

The serial plate is located under the cooktop (see Fig. 3).

When ordering parts for or making inquiries about your cooktop, always be sure to include the model and serial numbers from the serial plate on your cooktop.

## Before You Call for Service











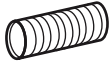

Read the Before You Call for Service Checklist and operating instructions in your **Use and Care Guide**. It may save you time and expense. The list includes common occurrences that are not the result of defective workmanship or materials in this appliance.

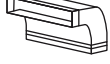
# ELECTRIC COOKTOP INSTALLATION INSTRUCTIONS

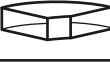
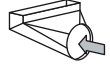
## Calculating Duct Length Table

For maximum efficiency, use the shortest and straightest duct possible. Use as few fittings as possible. For best performance, the duct run should not exceed 100 feet of equivalent length.

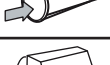
Calculations are approximate and based on HVAC industry standards.

DUCT PIECES		EQUIVALENT LENGTH X	NUMBER USED =	EQUIVALENT LENGTH
	6" (15.2cm) Round Straight **	1 Ft. (0.3m)		Ft. or m
	6" (15.2cm) Round Metal Flex No Bends **	1.5 Ft. (0.45m)		Ft. or m
	6" (15.2cm) 90° Elbow	10 Ft. (3m)		Ft. or m
	6" (15.2cm) 45° Elbow	5 Ft. (1.5m)		Ft. or m
	3 1/4" x 10" (8.2cm x 25.4cm) Straight **	1 Ft. (0.3m)		Ft. or m
	3 1/4" x 10" (8.2cm x 25.4cm) 90° Elbow	10 Ft. (3m)		Ft. or m
	3 1/4" x 10" (8.2cm x 25.4cm) 45° Elbow	5 Ft. (1.5m)		Ft. or m
	3 1/4" x 10" (8.2cm x 25.4cm) 90° Flat Elbow	10 Ft. (3m)		Ft. or m
	3 1/4" x 10" (8.2cm x 25.4cm) to 6" (15.2cm) Round Transition 90° Elbow	30 Ft. (9m)		Ft. or m
	6" (15.2cm) Round to 3 1/4" x 10" (8.2cm x 25.4cm) Transition 90° Elbow	30 Ft. (9m)		Ft. or m
	3 1/4" x 10" (8.2cm x 25.4cm) to 6" (15.2cm) Round Transition	5 Ft. (1.5m)		Ft. or m
	6" (15.2cm) Round to 3 1/4" x 10" (8.2cm x 25.4cm) Transition	5 Ft. (1.5m)		Ft. or m
	6" (15.2cm) Round Wall Cap with Damper	30 Ft. (9m)		Ft. or m
	3 1/4" x 10" (8.2cm x 25.4cm) Wall Cap with Damper	30 Ft. (9m)		Ft. or m
	6" (15.2cm) Round Roof Cap	30 Ft. (9m)		Ft. or m
TOTAL DUCTWORK				Ft. or m

\*\* For Straight Round / Rectangular Duct, measure actual linear feet used and then multiply by Equivalent Length shown.

# NOTES

# NOTES

# NOTES