

**CAUTION: DISCONNECT ELECTRIC CURRENT BEFORE SERVICING. LABEL ALL WIRES PRIOR TO DISCONNECTION WHEN SERVICING CONTROLS. WIRING ERRORS CAN CAUSE IMPROPER AND DANGEROUS OPERATION. VERIFY PROPER OPERATION AFTER SERVICING.**

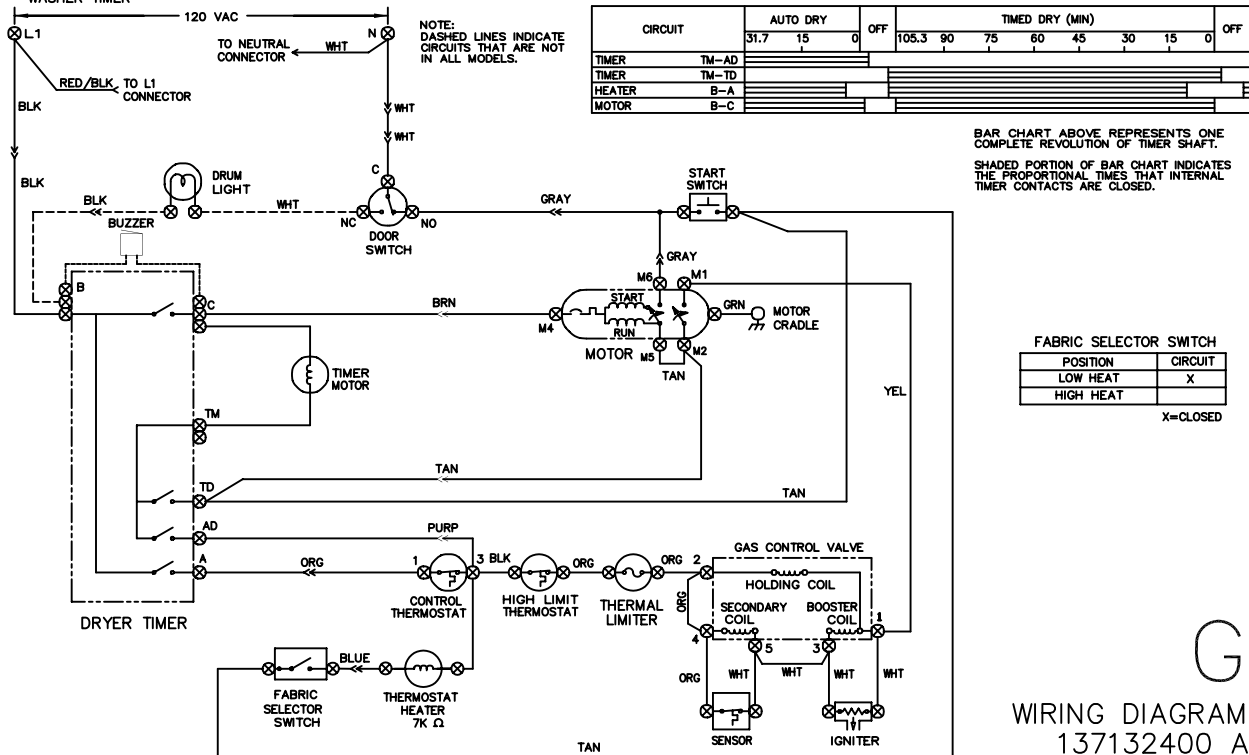

**ATENCIÓN: CUANDO SE REPARAN LOS CONTROLES, MARQUE TODOS CABLES CON ETIQUETAS ANTES DE DESCONECTARIOS. CUALQUIER ERRORES DE CABLEADO PUEDEN CAUSAR LA OPERACIÓN INADECUADA Y PELIGROSA. ASEGÚRESE DE QUE LA SECADORA FUNCIONE ADECUADAMENTE DESPUÉS DE REPARARLA.**

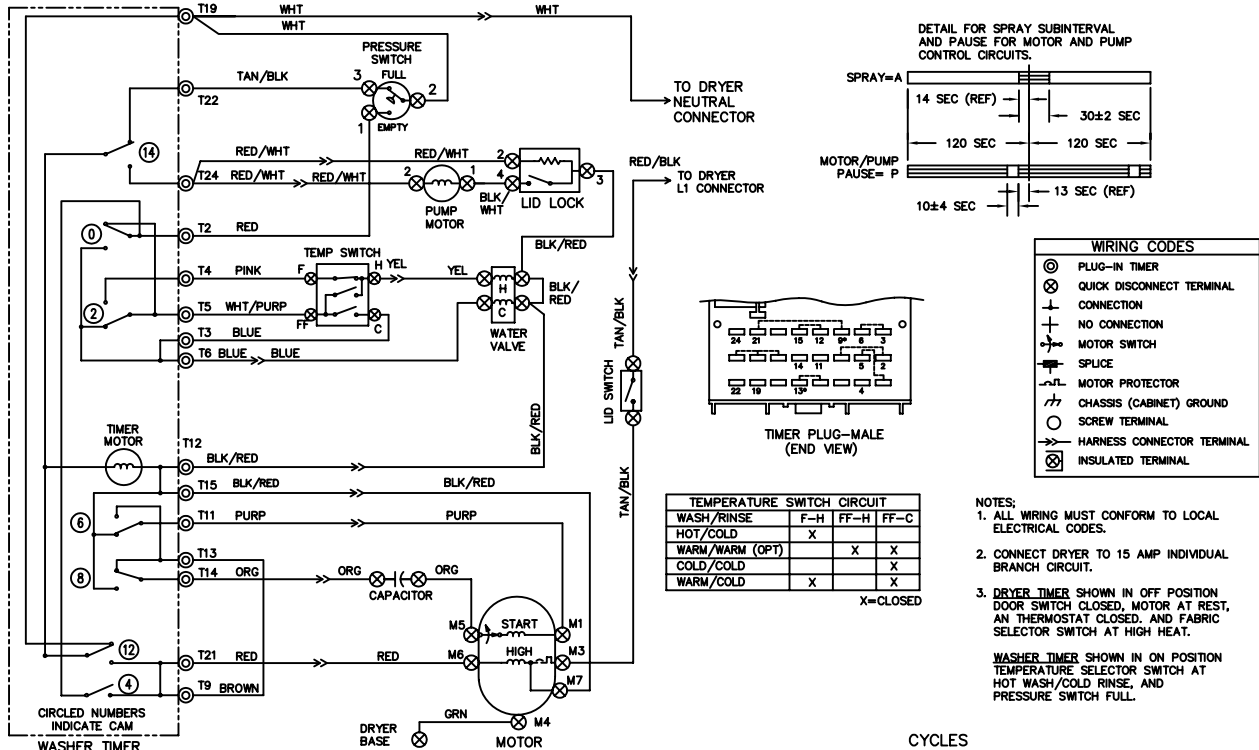
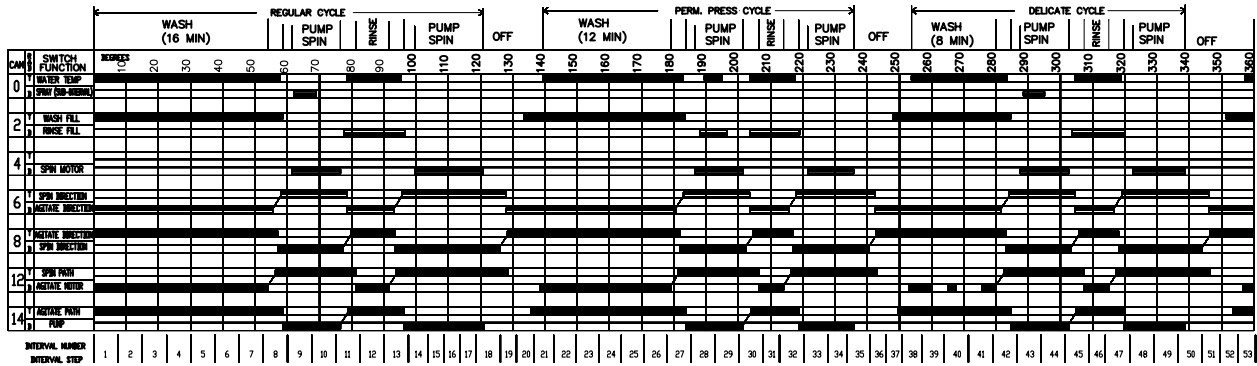
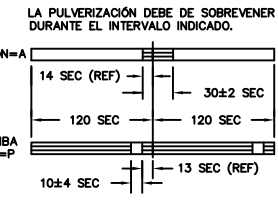
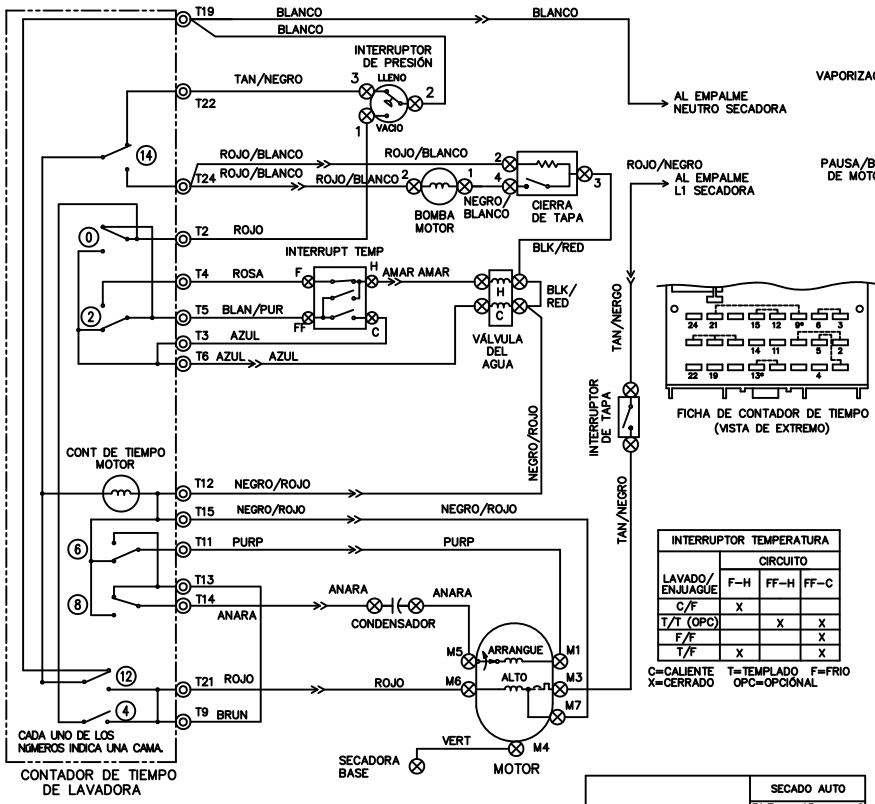
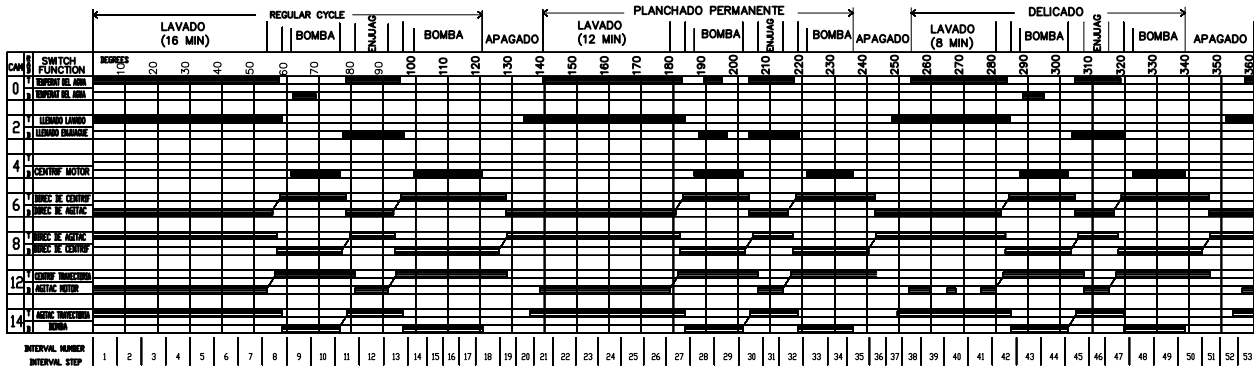

**INTERRUPTOR TEMPERATURA**

	F-H	FF-H	FF-C
LAVADO/ENJUAGUE	X	X	X
C/F	X	X	X
T/T (OPC)	X	X	X
F/F	X	X	X
T/F	X	X	X

C=CALIENTE T=TEMPERADO F=FRIO  
X=CERRADO OPC=OPCIONAL

**CICLOS**

	SECADO AUTO	APAGADO	SECADO CRONOMETRADO (MIN.)	APAGADO
CONTADOR TIEMPO TM-AD	31.7	15	0	105.3
CONTADOR TIEMPO TM-TD				90
CALENTADOR B-A				75
MOTOR B-C				60
				45
				30
				15
				0

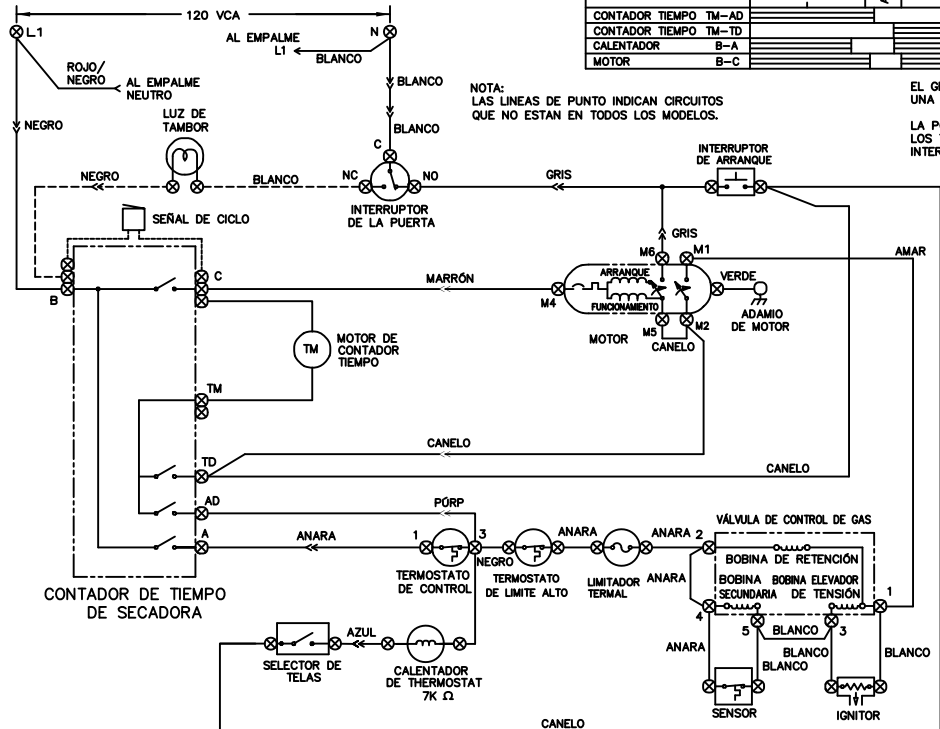

**DIAGRAMA DE CONEXIONES**

NO DE PIEZA 137132400 A