

# Installation Instructions

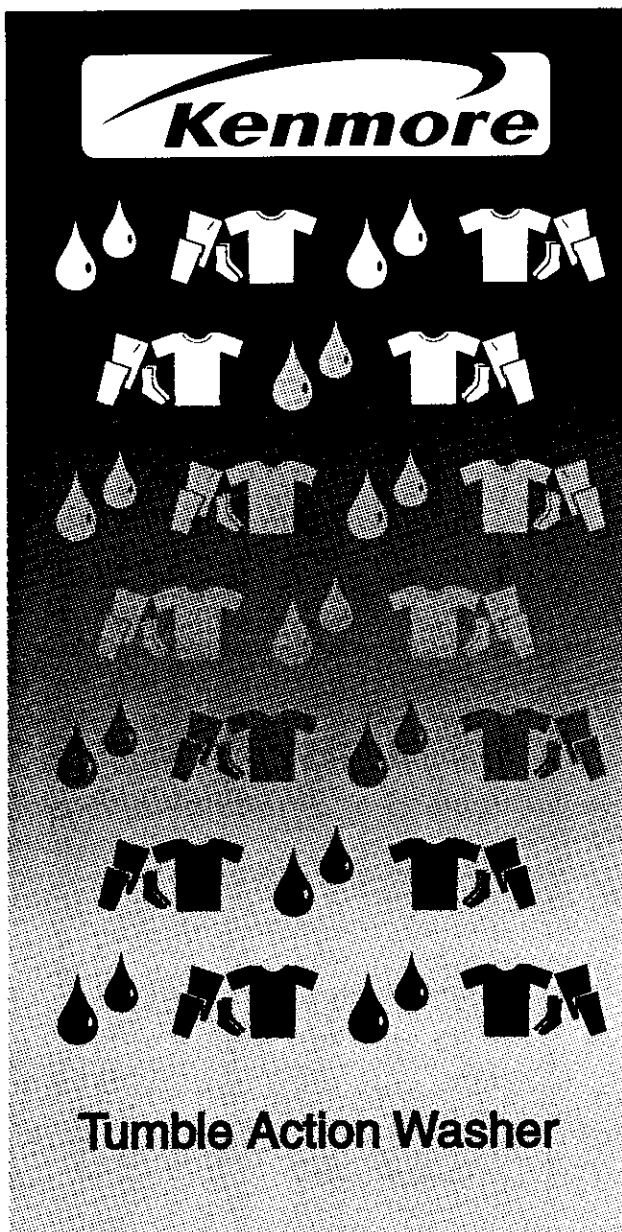

Pre-Installation Requirements .....	2
Electrical Requirements .....	2
Grounding Requirements .....	2
Water Supply Requirements .....	2
Drain Requirements .....	2
Rough-In Dimensions .....	3
Location Of Your Washer .....	4
Unpacking .....	4
Installation .....	5
Replacement Parts .....	5

Before beginning installation, carefully read these instructions. This will simplify the installation and ensure the washer is installed correctly and safely. Leave these instructions near the washer after installation for future reference.

NOTE: The electrical service to the Washer must conform with local codes and ordinances and the latest edition of the National Electrical Code, ANSI/NFPA 70.

**Save These Instructions**

**Sears, Roebuck and Co., Hoffman Estates, IL 60179 U.S.A.**

P/N 131996400 (0010)

**⚠ WARNING** For your safety the information in this manual must be followed to minimize the risk of fire or explosion or to prevent property damage, personal injury or loss of life.

- Do not store or use gasoline or other flammable vapors and liquid in the vicinity of this or any other appliance.
- **WHAT TO DO IF YOU SMELL GAS**
  - Do not try to light any appliance.
  - Do not touch any electrical switch; do not use any phone in your building.
  - Clear the room, building or area of all occupants.
  - Immediately call your gas supplier from a neighbor's phone. Follow the gas suppliers instructions.
  - If you cannot reach your gas supplier, call the fire department.

Installation and service must be performed by a qualified installer, service agency or the gas supplier.

## PRE-INSTALLATION REQUIREMENTS

### Tools Required for Installation:

1. 1/4 in. nut driver
2. 3/8 in. socket with ratchet.
3. 3/8 in. open end wrench.
4. 7/16 in. socket with ratchet.
5. 9/16 in. open end wrench.
6. Channel-lock adjustable pliers.
7. Carpenter's level.

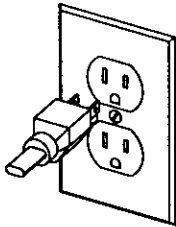

## ELECTRICAL REQUIREMENTS

**CIRCUIT** - Individual, properly polarized and grounded 15 amp. branch circuit fused with 15 amp. time delay fuse or circuit breaker.

**POWER SUPPLY** - 2 wire, with ground, 120 volt, single phase, 60 Hz, Alternating Current.

**OUTLET RECEPTACLE** - Properly grounded 3-prong receptacle to be located so the power supply cord is accessible when the washer is in an installed position.

## GROUNDING REQUIREMENTS

**⚠** Improper connection of the equipment grounding conductor can result in a risk of electrical shock. Check with a licensed electrician if you are in doubt as to whether the appliance is properly grounded.

1. The washer **MUST** be grounded. In the event of malfunction or breakdown, grounding will reduce the risk of electrical shock by a path of least resistance for electrical current.

2. Since your washer is equipped with a power supply cord having an equipment-grounding conductor and a grounding plug, the plug **MUST** be plugged into an appropriate, copper wired receptacle that is properly installed and grounded in accordance with all local codes and ordinances or in the absence of local codes, with the National Electrical Codes, ANSI/NFPA 70 (latest edition). If in doubt, call a licensed electrician. **DO NOT** cut off or alter the grounding prong on the power supply cord. In situations where a two-slot receptacle is present, it is the owner's responsibility to have a licensed electrician replace it with a **properly grounded** three prong grounding type receptacle.

## WATER SUPPLY REQUIREMENTS

Hot and cold water faucets **MUST** be installed within 42 inches (107 cm) of your washer's water inlet. The faucets **MUST** be 3/4 inch (1.9 cm) garden hose type so inlet hoses can be connected. Water pressure **MUST** be between 10 and 120 pounds per square inch (maximum unbalance pressure, hot vs. cold, 10 psi.) Your water department can advise you of your water pressure. The hot water temperature should be about 120 degrees F (49 degrees C).

## DRAIN REQUIREMENTS

1. Drain capable of eliminating 17 gals (64.3 L) per minute.
2. A standpipe diameter of 1-1/4 in. (3.18 cm) minimum.
3. The standpipe height above the floor should be:  
Minimum height: 24 in. (61 cm)  
Maximum height: 96 in. (244 cm)

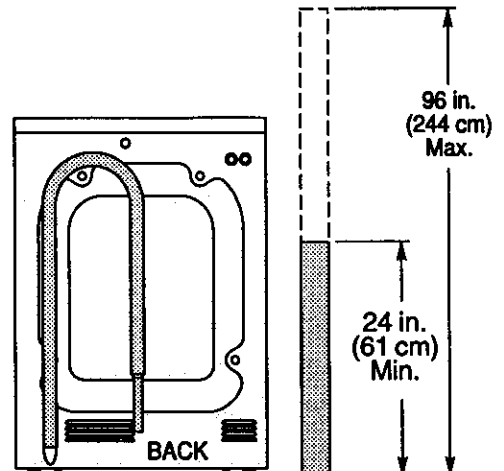

### NOTE:

Drain hose attached to the washer can reach a 58 in. (147 cm) high standpipe. For higher standpipe use hose P/N 131461201, available from Sears Parts and Service. If drain is less than 24 in. (61 cm), install a siphon break kit, DIV 26110285320, available from Sears Parts and Service.

## ROUGH-IN DIMENSIONS

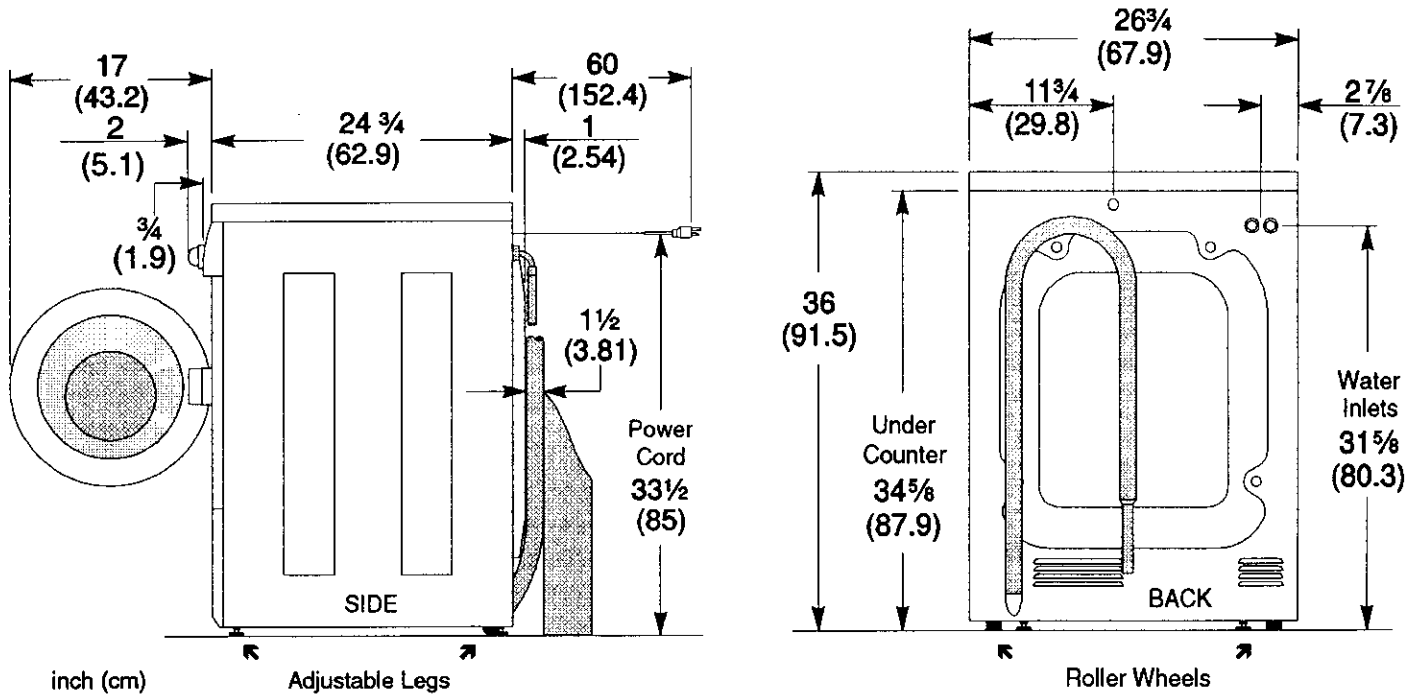

## UNDER COUNTER INSTALLATION

If an under counter\* installation is desired, the washer **MUST** have a top sheet kit installed, P/N 131445600. Kit is available from Sears Parts Department.

\*Custom sized countertop is required.

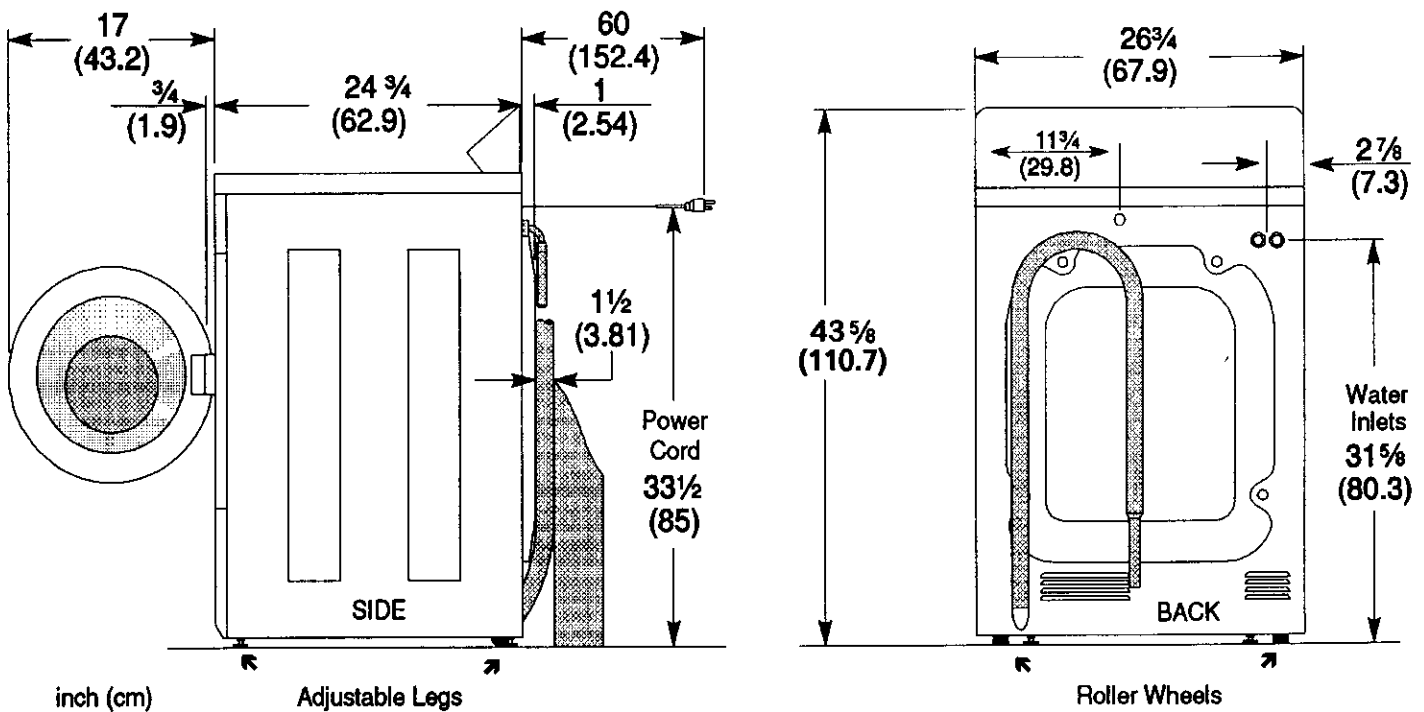

## LOCATION OF YOUR WASHER

### DO NOT INSTALL YOUR WASHER:

1. In an area exposed to dripping water or outside weather conditions. The ambient temperature should never be below 60 degrees F (15.6 degrees C) for proper washer operation.
2. In an area where it will come in contact with curtains or drapes.
3. In an area (garage or garage-type building) where gasoline or other flammables are kept or stored (including automobiles).
4. On carpet. Floor **MUST** be solid with a maximum slope of 1/2 in. per foot (1.27 cm per 30.5 cm). To ensure vibration or movement does not occur, reinforcement of the floor may be necessary.

### IMPORTANT MINIMUM INSTALLATION CLEARANCES

#### When installed in alcove or closet:

Sides, Rear = 0 in. (0 cm)

Top = 0 in. (0 cm) **Front Console Model**

Top = 15 in. (38.1 cm) **Rear Console Model**

#### When installed in closet: Front = 1 in. (2.54 cm)

Closet door ventilation required: 2 louvered openings each 60 in<sup>2</sup> (387 cm<sup>2</sup>), 3 in. (7.6 cm) from top and bottom of door.

## UNPACKING

1. Cut the shipping carton along the dotted line along the base of the unit.
2. While in the carton carefully lay the washer on its back side.

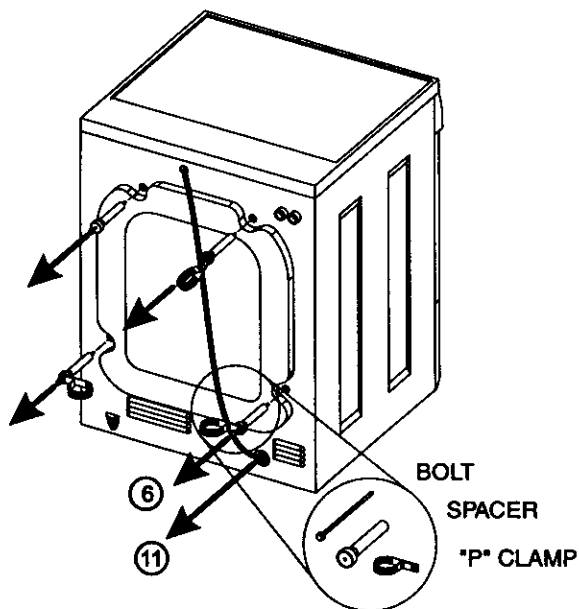

3. Remove the styrofoam base.
4. Carefully return the washer to an upright position and remove the carton.
5. Carefully move the washer to within 4 feet (122cm) of the final location.
6. Remove the following from the back side of the washer:
  - 4 bolts,
  - 4 yellow plastic spacers,
  - 3 metal "P" clamps.
7. Remove the service panel from the front of the washer.
8. Remove the 4 nuts and 6 large washers that attach the 2 yellow shipping braces to the drum and the base. Lift up on the drum and remove the braces (a yellow ribbon surrounds the items to be removed). These braces must be removed to allow the power supply cord to be released from the shipping ring.
9. Remove the large styrofoam block located under the drum. Lift up on the drum, tilt the base of the foam block inwards toward the rear of the washer until free, then pull it out.
10. Remove and discard the yellow ribbon and label from the front of the washer.

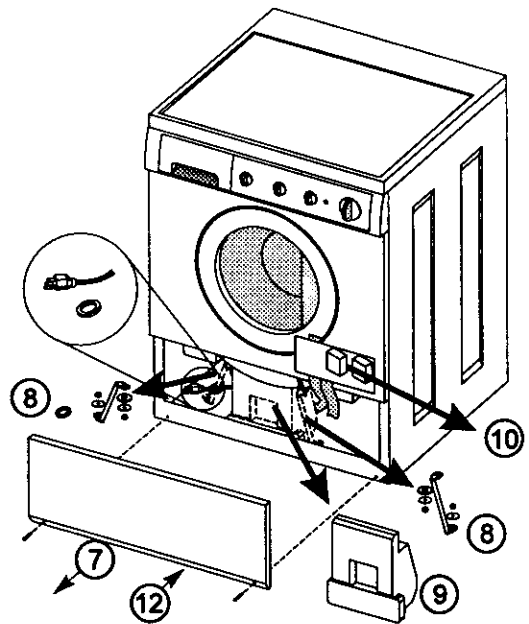

11. From the rear of the washer, carefully pull out the power supply cord through the hole in the backsheet.
12. Replace the service panel and screws.

**NOTE:** If the washer is to be transported at a later date, the shipping support hardware must be reinstalled to prevent shipping damage. Retain the hardware in the plastic bag provided.

## INSTALLATION

1. Run some water from the hot and cold faucets to flush the water lines and remove particles that might clog up the water valve screens.
2. Remove the inlet hoses and rubber washers from the plastic bag and install the rubber washers in each end of the inlet hoses.
3. (90° elbow end) Carefully connect the inlet hose marked "HOT" to the outside "H" outlet of the water valve. Tighten by hand, then tighten another 2/3 turn with pliers.

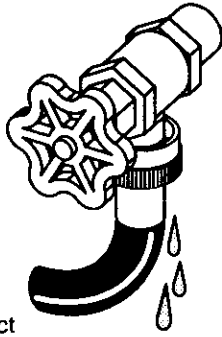

Carefully connect the other inlet hose to the inside "C" outlet of the water valve. Tighten by hand, then tighten another 2/3 turn with pliers.

**Do not crossthread or over-tighten these connections.**

4. Connect the inlet hose ends to the HOT and COLD water faucets tightly by hand, then tighten another 2/3 turn with pliers. Turn the water on and check for leaks. **NOTE:** Use only new hoses provided with this unit.
5. Carefully move the washer to its final location. Rollers on the rear of the washer allow for easy movement in undercounter installations. Gently lift up on the front of the washer and slide back. **NOTE:** Lifting up more than 1/8" will engage the rear legs. Do not use the dispenser drawer or door to lift washer.
6. With the washer in its final position, place a level on top of the washer (if an undercounter installation, no rocking of the washer should exist). Adjust the front leveling legs up or down to ensure the washer is resting solid. Turn the lock nuts on each leg up towards the base of the washer and snug with a wrench. **NOTE:** Keep the leg extension at a minimum to prevent excessive vibration. The farther out the legs are extended the more the washer will vibrate.

The washer is designed to operate resting on its rear rollers. If the floor is not level or is damaged, the rear leveling legs may have to be extended. For undercounter installations, rear leg adjustment is accessible through the front service panel.

7. Form a U shape on the end of the drain hose with the hose pointed toward the drain. Place in a laundry tub or standpipe and secure with the cable tie provided in the enclosure package.

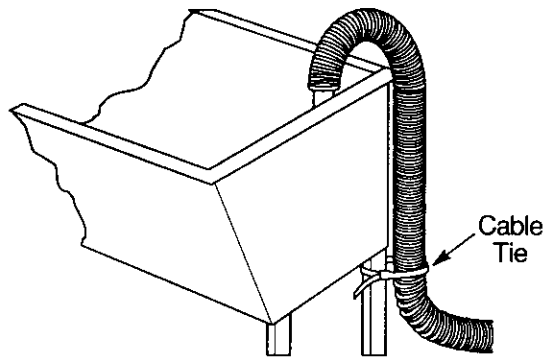
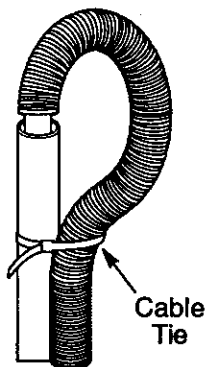
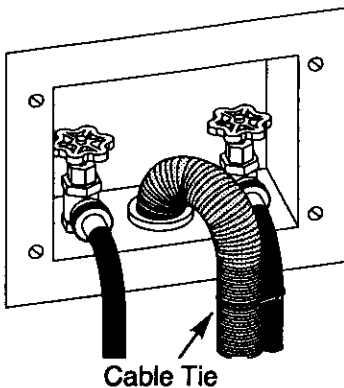

**NOTE:** If the drain hose is placed in a standpipe without forming a U shape, a siphoning action could occur. There must be an air gap around the drain hose. A snug hose fit can also cause a siphoning action.

8. Plug the power cord into a grounded outlet. **NOTE:** Check to ensure the power is off at a circuit breaker/fuse box before plugging the power cord into an outlet.
9. Turn on the power at a circuit breaker/fuse box.
10. Read the Operating Instructions and Owner's Guide provided with the washer. They contain valuable and helpful information that will save you time and money.
11. Run the washer through a complete cycle. Check for water leaks and proper operation.
12. If your washer does not operate, please review the "Avoid Service Checklist" in your Owner's Guide before calling for service.
13. Place these instructions in a location near the washer for future reference.

**NOTE:** A wiring diagram is located inside the washer on the service panel.

## REPLACEMENT PARTS

If replacement parts are needed for your washer, call **Sears Parts and Service Toll Free Number 1-800-366-PART (1-800-366-7278)**.

**⚠ WARNING** Destroy the carton and plastic bags after the washer is unpacked. Children might use them for play. Cartons covered with rugs, bedspreads, or plastic sheets can become airtight chambers causing suffocation. Place all materials in a garbage container or make materials inaccessible to children.

**⚠ WARNING** The instructions in this manual and all other literature included with this washer are not meant to cover every possible condition and situation that may occur. Good safe practice and caution **MUST** be applied when installing, operating and maintaining any appliance.

Maximum benefits and enjoyment are achieved when all the Safety and Operating instructions are understood and practiced as a routine with your laundering tasks.