

Sears

**owners
manual**

MODEL NO.
113.19770
SAW ONLY
113.197750
SAW WITH LEGS

Serial
Number _____

Model and serial
number may be found
at the front of the base.

You should record both
model and serial number
in a safe place for
future use.

CAUTION:

Read **GENERAL**
and **ADDITIONAL**
SAFETY
INSTRUCTIONS
carefully

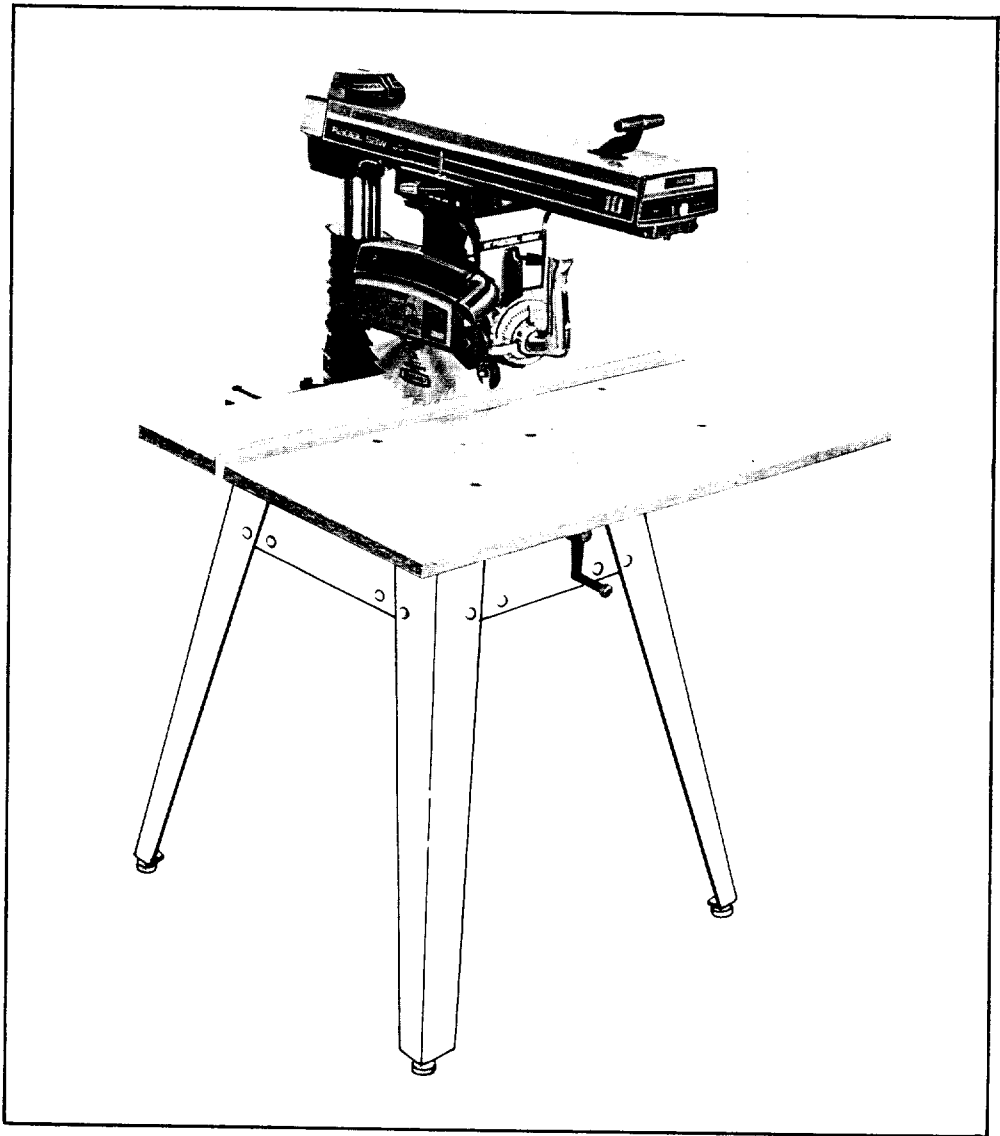

Sears **CRAFTSMAN®**

**10-INCH
RADIAL SAW**

- *assembly*
- *operating*
- *repair parts*



Sold by SEARS, ROEBUCK AND CO., Chicago, IL. 60684 U.S.A.

FULL ONE YEAR WARRANTY ON CRAFTSMAN RADIAL SAWS

If within one year from the date of purchase, this Craftsman Radial Saw fails due to a defect in material or workmanship, Sears will repair it, free of charge.

Warranty service is available by simply contacting the nearest Sears store or Service Center throughout the United States.

This warranty gives you specific legal rights, and you may also have other rights which vary from state to state.

SEARS, ROEBUCK AND CO.
BSC 41-3
SEARS TOWER
CHICAGO, IL 60684

general safety instructions for power tools

1. KNOW YOUR POWER TOOL

Read the owner's manual carefully. Learn its application and limitations as well as the specific potential hazards peculiar to this tool.

2. GROUND ALL TOOLS

This tool is equipped with an approved 3-conductor cord and a 3-prong grounding type plug to fit the proper grounding type receptacle. The green conductor in the cord is the grounding wire. Never connect the green wire to a live terminal.

3. KEEP GUARDS IN PLACE

in working order, and in proper adjustment and alignment.

4. REMOVE ADJUSTING KEYS AND WRENCHES

Form habit of checking to see that keys and adjusting wrenches are removed from tool before turning it on.

5. KEEP WORK AREA CLEAN

Cluttered areas and benches invite accidents. Floor must not be slippery due to wax or sawdust.

6. AVOID DANGEROUS ENVIRONMENT

Don't use power tools in damp or wet locations or expose them to rain. Keep work area well lighted. Provide adequate surrounding work space.

7. KEEP CHILDREN AWAY

All visitors should be kept a safe distance from work area.

8. MAKE WORKSHOP KID-PROOF

— with padlocks, master switches, or by removing starter keys.

9. DON'T FORCE TOOL

It will do the job better and safer at the rate for which it was designed.

10. USE RIGHT TOOL

Don't force tool or attachment to do a job it was not designed for.

11. WEAR PROPER APPAREL

Do not wear loose clothing, gloves, neckties or jewelry (rings, wrist watches) to get caught in moving parts. Nonslip footwear is recommended. Wear protective hair covering to contain long hair. Roll long sleeves above the elbow.

12. USE SAFETY GOGGLES (Head Protection)

Wear Safety goggles (must comply with ANS Z87.1) at all times. Also, use face or dust mask if cutting operation is dusty, and ear protectors (plugs or muffs) during extended periods of operation.

13. SECURE WORK

Use clamps or a vise to hold work when practical. It's safer than using your hand, frees both hands to operate tool.

14. DON'T OVERREACH

Keep proper footing and balance at all times.

15. MAINTAIN TOOLS WITH CARE

Keep tools sharp and clean for best and safest performance. Follow instructions for lubricating and changing accessories.

16. DISCONNECT TOOLS

before servicing; when changing accessories such as blades, bits, cutters, etc.

17. AVOID ACCIDENTAL STARTING

Make sure switch is in "OFF" position before plugging in.

18. USE RECOMMENDED ACCESSORIES

Consult the owner's manual for recommended accessories. Follow the instructions that accompany the accessories. The use of improper accessories may cause hazards.

19. NEVER STAND ON TOOL

Serious injury could occur if the tool is tipped or if the cutting tool is accidentally contacted.

Do not store materials above or near the tool such that it is necessary to stand on the tool to reach them.

20. CHECK DAMAGED PARTS

Before further use of the tool, a guard or other part that is damaged should be carefully checked to ensure that it will operate properly and perform its intended function. Check for alignment of moving parts, binding of moving parts, breakage of parts, mounting, and any other conditions that may affect its operation. A guard or other part that is damaged should be properly repaired or replaced.

21. DIRECTION OF FEED

Feed work into a blade or cutter against the direction of rotation of the blade or cutter only.

22. NEVER LEAVE TOOL RUNNING UNATTENDED

Turn power off. Don't leave tool until it comes to a complete stop.

additional safety instructions for radial saws

CAUTION. Always disconnect the power cord before removing the guard, changing the cutting tool, changing the set-up or making adjustments. Shut off motor before performing layout work on the saw table.

WARNING: DO NOT CONNECT POWER CORD UNTIL THE FOLLOWING STEPS HAVE BEEN SATISFACTORILY COMPLETED:

- I. Assembly and alignment.
- II. Examination and operating familiarity with ON-OFF switch, elevation control, yoke index and lock bevel index and lock, carriage lock, guard clamp screw, spreader and antikickback device, and miter index and lock.
- III. Review and understanding of all Safety Instructions and Operating Procedures thru-out manual.

INSTALLATION

1. Set carriage lock before moving the saw.
2. Bolt the saw to the floor if it tends to slip, walk, or slide during normal operation.
3. Mount the saw so the table is approximately 39" above the floor.
4. Mount the saw so the arm slopes slightly downward to the rear so the carriage will not roll forward due to gravity

MINIMIZE ACCIDENT POTENTIAL

Most accidents are caused by FAILURE TO FOLLOW setup and operating instructions:

(A) GENERAL

- Avoid awkward hand positions, where a sudden slip could cause a hand to move into a sawblade or other cutting tool. Never reach in back of or around the cutting tool with either hand to hold down the workpiece, or for any other reason; DO NOT place fingers or hands in the path of the sawblade.
- Never saw, dado, mold, or rabbet unless the proper guard is installed and set up as instructed.
- NOTE THE FOLLOWING DANGER LABELS WHICH APPEAR ON THE FRONT OF THE YOKE AND GUARD:

DANGER: FOR YOUR OWN SAFETY	
READ AND UNDERSTAND OWNER'S MANUAL BEFORE OPERATING MACHINE.	
1. WEAR SAFETY GOGGLES.	4. USE "PUSH STICK" FOR NARROW WORK.
2. KEEP HANDS OUT OF PATH OF SAWBLADE.	5. NEVER REACH AROUND THE SAWBLADE.
3. KNOW HOW TO AVOID "KICKBACKS".	6. ALLOW TOOL TO STOP BEFORE ADJUSTING.
WARNING: TO AVOID INJURY RETURN CARRIAGE TO THE FULL REAR POSITION AFTER EACH CROSSCUT TYPE OF OPERATION.	

DANGER
TO AVOID INJURY DO NOT FEED MATERIAL INTO CUTTING TOOL FROM THIS END

- If any part of this radial saw is missing or should break, bend or fail in any way, or any electrical component fail to perform properly, shut off power switch, remove cord from power supply and replace damaged, missing and/or failed parts before resuming operation.
- IF YOUR SAW MAKES AN UNFAMILIAR NOISE OR IF IT VIBRATES EXCESSIVELY CEASE OPERATING IMMEDIATELY UNTIL THE SOURCE HAS BEEN LOCATED AND THE PROBLEM CORRECTED.
- **WARNING: DO NOT ALLOW FAMILIARITY (GAINED FROM FREQUENT USE OF YOUR SAW) TO BECOME COMMONPLACE. ALWAYS REMEMBER THAT A CARELESS FRACTION OF A SECOND IS SUFFICIENT TO INFLICT SEVERE INJURY.**
- Before starting work, verify that no play exists between the column & column support, or in the carriage, and that arm, yoke, and bevel locks/clamps are tight.

- A large proportion of saw accidents is caused by use of the wrong type blade, dull, badly set, improperly sharpened cutting tools, by gum or resin adhering to cutting tools, and by sawblade misalignment out-of-parallel with the fence. Such conditions can cause the material to stick, jam (stall the saw) or "KICKBACK" at the operator. NEVER ATTEMPT TO FREE A STALLED SAW BLADE WITHOUT FIRST TURNING THE SAW "OFF". If the sawblade is stalled or jammed, shut saw "OFF", remove workpiece, and check sawblade squareness to table surface and to the fence, and check for heel. Adjust as indicated.

- **CAUTION: DO NOT cycle the motor switch "ON" and "OFF" rapidly, as this might cause the sawblade to loosen. In the event this should ever occur, allow the saw blade to come to a complete stop and re-tighten the arbor nut normally, not excessively.**

- Do not leave a long board unsupported so the spring of the board causes it to shift on the table. Provide proper support for the workpiece, based on its size and the type of operation to be performed. Hold the work firmly against the fence.

- Never use a length stop on the free end or edge of the workpiece whether crosscutting or ripping. Never hang onto or touch the free end of workpiece when crosscutting, or a free piece that is cut off while power is "ON" and/or the saw blade is rotating. In short, the cut-off piece in any "thru-sawing" operation must never be confined - it must be allowed to move laterally.

- Make sure your fingers do not contact the terminals when installing or removing the plug to or from a live power source.

- Never climb on the saw, or climb near the saw when power is "ON". Never leave the saw with power "ON", or before the cutting tool has come to a complete stop. Lock the motor switch and put away the key when leaving the saw.

- Do not use any blade or other cutting tool marked for an operating speed lower than 3450 RPM. Never use a cutting tool larger in diameter than the diameter for which the saw was designed. For greatest safety and efficiency when ripping, use the maximum diameter blade for which the saw is designed, since under these conditions the spreader is nearest the blade.

- Never turn your saw "ON" before clearing the table or work surface of all objects (tools, scraps of wood, etc.) except the workpiece and related feed or support devices for the operation planned.

- DO NOT perform layout, assembly, or setup work on the table while the cutting tool is rotating.

- Never perform any operation "FREE HAND". This term means feeding the sawblade into the workpiece or feeding the workpiece into the sawblade or other cutting tool without using the fence or some other device which prevents rotation or twisting of the workpiece during the operation. Never "RIP" in the crosscut position. Never make a miter cut with the arm in the 90° crosscut position.

- Never lower a revolving cutting tool into the table or a workpiece without first locking the Carriage Lock Knob. Release the knob only after grasping the Yoke Handle. Otherwise the cutting tool may grab the workpiece and be propelled toward you.

- The sawblade, dado, or other cutting tool must be

additional safety instructions for radial saws

removed from the saw arbor before using the accessory shaft (rear end of the saw motor). NEVER operate the saw with cutting tools (including sanding accessories) installed on both ends of the saw arbor.

(B) RIPPING

1. Never apply the feed force to the section of the workpiece that will become the cut-off (free) piece. Feed force when ripping must always be applied between the saw blade and the fence ... use a "PUSH STICK" (see pg. 26) for narrow or short work.
2. Whenever possible, use the in-rip position – this provides minimum obstruction for feeding by hand or push stick as appropriate.
3. Do not release the workpiece before operation is complete – push the workpiece all the way past the rear (outfeed or exit) of the sawblade.
4. Make sure by trial before starting the cut that the antikickback pawls will stop a kickback once it has started. Keep points of pawls SHARP!
5. Use a push stick when ripping short (under 12 inches) or narrow (under 6 inches wide) workpieces.
6. **CAUTION: Never reposition the Guard or antikickback with power "ON".**
7. A "KICKBACK" occurs during a rip-type operation when a part or all of the workpiece is thrown back violently toward the operator. It can occur when the workpiece closes in on the rear (outfeed side) of the sawblade (pinching), binds between the fence and the sawblade (heel), or is grabbed by the sawblade teeth (wrong-way feed) at the outfeed side. "PINCHING" is generally avoided by utilization of the spreader, and a sharp sawblade of the correct type for the workpiece being cut. "HEEL" can be avoided by maintaining the sawblade exactly parallel to the fence. Grabbing by the sawblade teeth can be caused by heel or by feeding from the wrong direction (see "DANGER" warning on guard) – it can be avoided by maintaining parallelism of sawblade to fence, feeding into the sawblade from the nose of the guard only, and by positioning the spreader and antikickback property, and keeping the workpiece down on the table and against the fence.
8. Position the nose of the guard to just clear the workpiece, and position/adjust the antikickback and spreader devices as instructed.
9. NEVER cut more than one piece at a time by stacking workpieces vertically.
10. NEVER feed a workpiece thru the saw with another piece (butting second piece against trailing edge of piece being cut), even if of the same thickness. Feed each workpiece individually thru the sawblade, and completely beyond the sawblade, before ripping the next workpiece. Use push stick if the rip cut is less than 6" wide.
11. DO NOT pull the workpiece thru the sawblade
 - position your body at the nose (in-feed) side of the guard: start and complete the cut from that same side. This will require added table support for long pieces.
12. Plastic and composition (like hardboard) materials may be cut on your saw. However, since these are usually quite hard and slippery, the antikickback pawls may not stop a kickback.
Therefore, rip with the finished side down (next to the table) and be especially attentive to following

proper set-up and cutting procedures. Do not stand, or permit anyone else to stand, in line with a potential kickback.

13. When sawing 1/4" or thinner materials, follow all normal ripping procedures except set sawblade into table top at least 1/8". DO NOT let go of or stop feeding the workpiece between the blade and fence until you have pushed it completely past the antikickback pawls. Otherwise the workpiece could get into the back of the sawblade and be thrown violently from the saw in the direction opposite to the feed direction. This is the same action that would occur if the instructions of the DANGER warning on the guard is aborted. Do not stand, or permit anyone else to stand, in line with the path of a workpiece that may be thrown from the saw in this manner.
14. Position the saw so neither you, a helper, or a casual observer is forced to stand in line with the sawblade.
15. Use extra care when ripping wood that has a twisted grain or is twisted or bowed – it may rock on the table and/or pinch the sawblade.

(C) CROSSCUTTING

1. ALWAYS RETURN THE CARRIAGE TO THE FULL REARWARD POSITION AT CONCLUSION OF EACH CROSSCUT TYPE OPERATION. Never remove your hand from the Yoke Handle unless the carriage is in this position. Otherwise the cutting tool may climb up on the workpiece and be propelled toward you.
2. Place guard in horizontal position and adjust antikickback pawls to just clear the top of the fence or workpiece, whichever is higher.
3. NEVER gang crosscut – lining up more than one workpiece in front of the fence – stacked vertically, or horizontally outward on the table – and then pulling saw thru: the blade could pick up one or more pieces and cause a binding or loss of control and possible injury.
4. Do not position the Arm so the operation you are performing permits the cutting tool to extend beyond the edges of the Table.

(D) ACCESSORIES

1. Use only recommended accessories as listed on page 34.
2. Never operate this saw when equipped with a dado head or molding head unless the molding head guard is installed – see listing of recommended accessories. The only exception is when "top-side" dadoing or molding, when the sawblade guard must be used. See detailed instructions that accompany the dado head, molding head, and molding head guard.
3. The use of abrasive or cut-off wheels, or wire wheels, can be dangerous and is not recommended. (Abrasive or cut-off wheels are used to saw many different materials including metals, stone, and glass.)
4. Drill Chuck: Do not install or use any twist drill larger than 1/2-inch in dia., or longer than 7 inches in length or extending more than 6 inches beyond the chuck jaws. Do not install or use any reduced shank drill except of the spade type (1 inch dia. or smaller). "Use for drilling WOOD and PLASTIC only."



The operation of any power tool can result in foreign objects being thrown into the eyes, which can result in severe eye damage. Always wear safety goggles complying with ANSI Z87.1 (shown on Package) before commencing power tool operation. Safety Goggles are available at Sears retail or catalog stores.

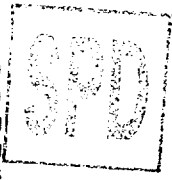

electrical connections

POWER SUPPLY

1. Motor Specifications

The A-C motor used in this saw is a capacitor-start, non-reversible type having the following specifications:

- Voltage 120/240
- Amperes 11/5.5
- Hertz (cycles) 60
- Phase Single
- RPM 3450
- Rotation as viewed from saw blade end Clockwise

CAUTION: Your saw is wired for 120V operation. Connect to a 120V, 15-Amp. branch circuit and use a 15-Amp. time-delay fuse or circuit breaker. If the motor is used for 240V operation, connect to a 15-Amp. branch circuit and use a 15-Amp. time-delay fuse or circuit breaker.

This machine must be grounded while in use to protect the operator from electric shock.

IF YOU ARE NOT SURE THAT YOUR OUTLET IS PROPERLY GROUNDED, HAVE IT CHECKED BY A QUALIFIED ELECTRICIAN.

WARNING: DO NOT PERMIT FINGERS TO TOUCH THE TERMINALS OF PLUGS WHEN INSTALLING OR REMOVING THE PLUG TO OR FROM THE OUTLET.

WARNING: IF NOT PROPERLY GROUNDED THIS POWER TOOL CAN INCUR THE POTENTIAL HAZARD OF ELECTRICAL SHOCK. PARTICULARLY WHEN USED IN DAMP LOCATIONS IN PROXIMITY TO PLUMBING. IF AN ELECTRICAL SHOCK OCCURS THERE IS THE POTENTIAL OF A SECONDARY HAZARD SUCH AS YOUR HANDS CONTACTING THE SAWBLADE.

IF POWER CORD IS WORN OR CUT, OR DAMAGED IN ANY WAY, HAVE IT REPLACED IMMEDIATELY.

If your unit is for use on less than 150 volts it has a plug that looks like below.

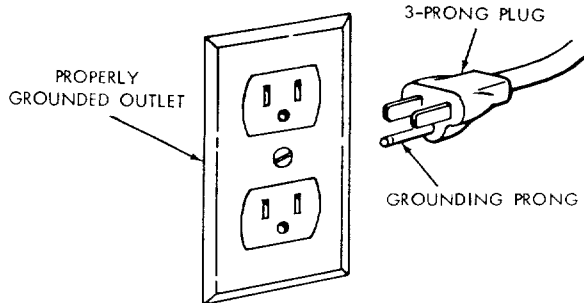

This power tool is equipped with a 3-conductor cord and grounding type plug which has a grounding prong, Listed by Underwriters' Laboratories. The ground conductor has a green jacket and is attached to the tool

housing at one end and to the ground prong in the attachment plug at the other end.

This plug requires a mating 3-conductor grounded type outlet as shown.

If the outlet you are planning to use for this power tool is of the two prong type **DO NOT REMOVE OR ALTER THE GROUNDING PRONG IN ANY MANNER.** Use an adapter as shown and always connect the grounding lug to known ground.

It is recommended that you have a qualified electrician replace the TWO prong outlet with a properly grounded THREE prong outlet.

An adapter as shown below is available for connecting plugs to 2-prong receptacles. The green grounding lug extending from the adapter must be connected to a permanent ground such as to a properly grounded outlet box.

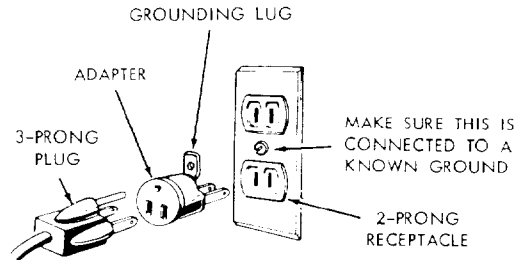

NOTE: The adapter illustrated is for use only if you already have a properly grounded 2-prong receptacle.

ELECTRICAL CONNECTIONS

WARNING: CHANGES IN ELECTRICAL CONNECTIONS SHOULD BE MADE BY A QUALIFIED ELECTRICIAN.

1. Changing Motor Connections

a. Under normal home workshop usage, and if proper (full) voltage is supplied to the motor, your saw will operate efficiently on 120V, as connected at the factory. However, if any of the following conditions exists, it will be advisable for you to reconnect the motor for 240V operation -- to obtain the efficiency and performance for which your saw is designed:

- (1) Heavy-duty operations.
- (2) Either an undersized or an overloaded branch circuit serving the saw motor.
- (3) Low voltage supplied by the power source, which the power company cannot correct.

b. Motor wiring connections for 120V (as made at the factory) are described below. Necessary reconNECTIONS for 240V operation are also described following. Whenever changing connections from 120V to 240V or vice-versa, make certain that *all* necessary steps (including proper fusing of the branch circuit) are completed.

electrical connections

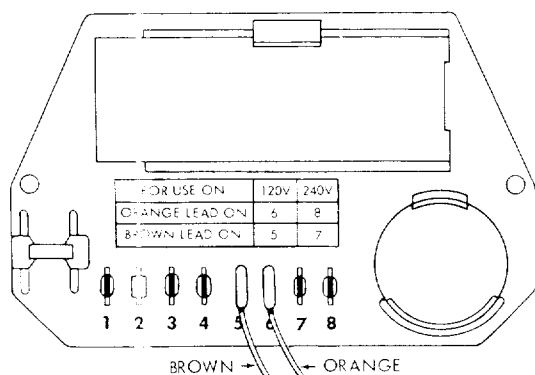

2. Connections for 120V A.C.

- Remove nameplate cover from motor to expose terminal board.
- The wires inside of the motor must be connected as shown:
 - The orange-colored wire on number 6 terminal.
 - The brown-colored wire on number 5 terminal.
- Use the 120V power-cord plug furnished with your saw.

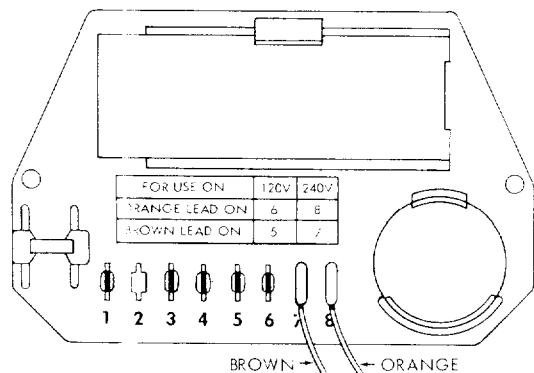

3. Connections for 240V A.C.

- The wires inside the motor terminal box must be connected as follows:
 - The orange-colored wire on number 8 terminal.
 - The brown-colored wire on number 7 terminal.
- Replace the 120V power-cord plug with a (3-blade) 240V plug, connecting the power-cord white and black leads, respectively, to the two "hot" plug blades – and connecting the power-cord grounding wire to the plug ground prong.

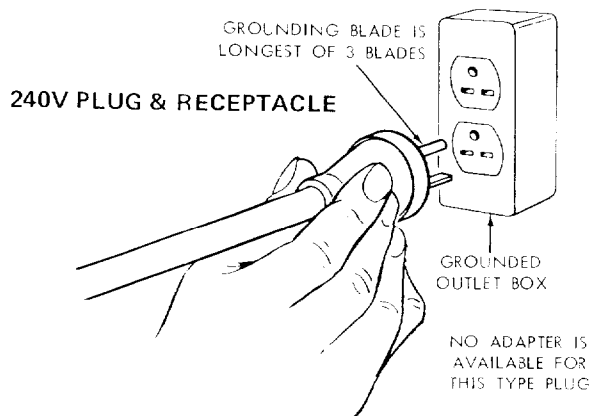

- Plug your saw into a 240V, 3-blade receptacle.

- Make certain the receptacle is connected to a 240V A-C power supply through a 240V branch circuit having at least a 15-amp. capacity, and protected by a 15-amp. time-delay fuse or circuit breaker.

MOTOR SAFETY PROTECTION

NOTE: This motor should be blown out, or "vacuumed", frequently to prevent sawdust interference with normal motor ventilation.

Your saw motor is equipped with a manual-reset, thermal-overload protector designed to open the power-line circuit when the motor temperature exceeds a safe value.

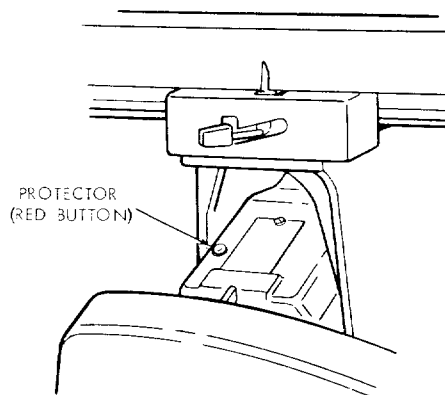

- If the protector opens the line and stops the saw motor, immediately press the saw switch to the "OFF" position, and allow the motor to cool.
- After cooling to a safe operating temperature, the overload protector can be closed manually by pushing in the red button on the top of the motor. If the red button will not snap into place immediately, the motor is still too hot and must be allowed to cool for a while longer. In some cases this may take 20-30 minutes. (An audible click will indicate protector is closed.)
- As soon as the red button will snap into running position, the saw may be started and operated normally, by pulling out the saw switch to the "ON" position.
- Frequent opening of fuses or circuit breakers may result if motor is overloaded, or if the motor circuit is fused differently from recommendations. Overloading can occur if you feed too rapidly or if your saw is misaligned so that the blade heels. Do *not* use a fuse of greater capacity without consulting a qualified electrician.
- Although the motor is designed for operation on the voltage and frequency specified on motor nameplate, normal loads will be handled safely on voltages not more than 10% above or below the nameplate voltage. Heavy loads, however, require that voltage at motor terminals equals the voltage specified on nameplate.
- Most motor troubles may be traced to loose or incorrect connections, overloading, reduced input voltage (such as small size wires in the supply circuit) or to an overly-long supply circuit. Always check the connections, the load and the supply circuit, whenever the motor fails to perform satisfactorily. Check wire sizes and lengths with the table following.

WIRE SIZES

The use of any extension cord will cause some loss of power. To keep this to a minimum and to prevent

over-heating and motor burn-out, use the table below to determine the minimum wire size (A.W.G.) extension cord. Use only 3 wire extension cords which have 3 prong grounding type plugs and 3-pole receptacles which accept the tools plug.

NOTE: For circuits of greater length, the wire size must be increased proportionately in order to deliver ample voltage to the saw motor.

Length of the Conductor	Wire Size Required (American Wire Gauge Number)	
	240 Volt Lines	120 Volt Lines
Up to 100 feet	No. 14	No. 12
100 feet to 200 feet	No. 12	No. 8
200 feet to 400 feet	No. 8	No. 6

LOCATIONS AND FUNCTIONS OF CONTROLS

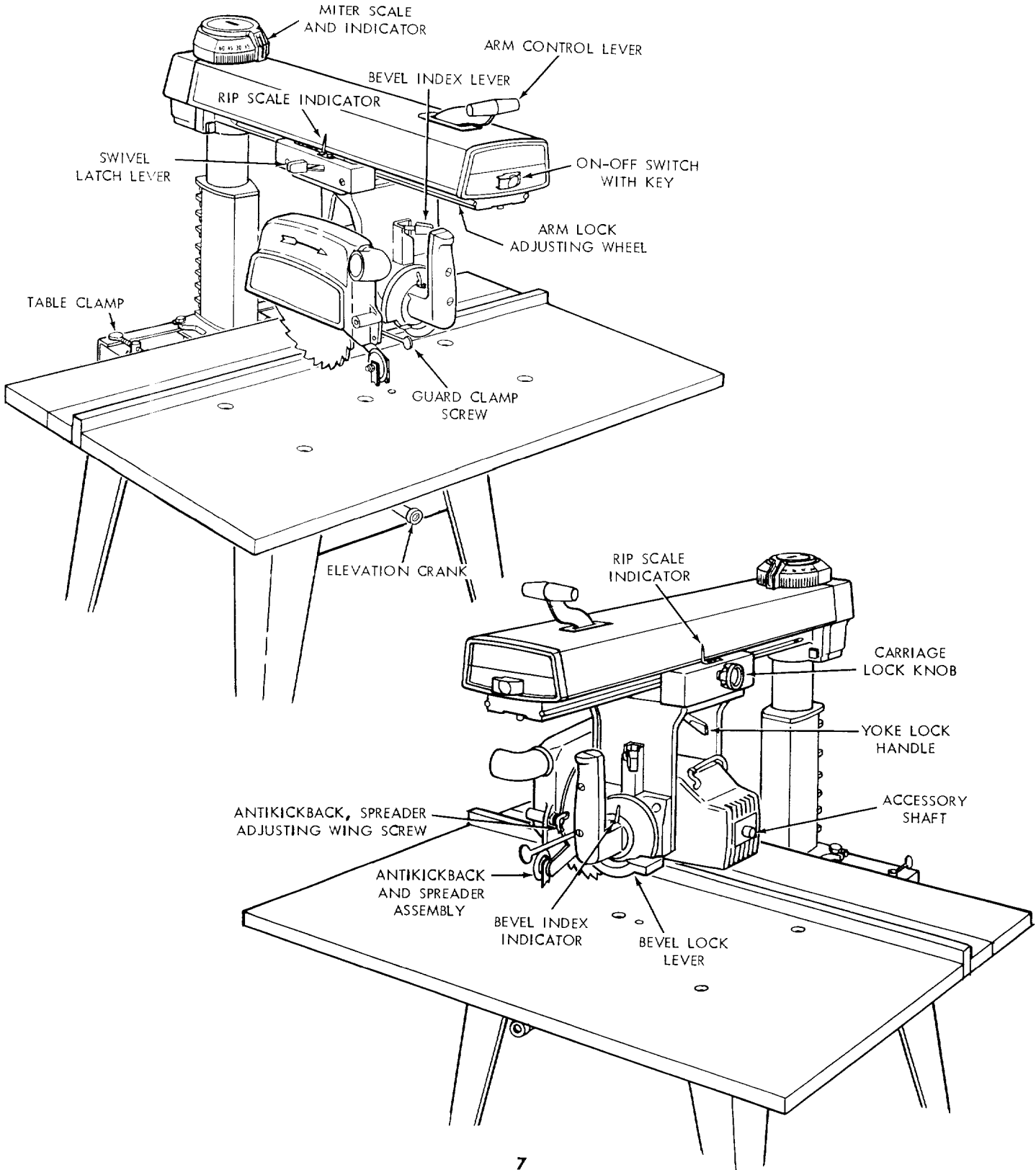

CONTENTS

<p>Guarantee 2</p> <p>General Safety Instructions for Power Tools 2</p> <p>Additional Safety Instructions for Radial Saws 3</p> <p>Electrical Connections 5</p> <p>Assembly and Alignment 8</p> <p style="padding-left: 20px;">Unpacking and Preassembly 8</p> <p style="padding-left: 20px;">Alignment Procedure 12</p>	<p>Location and Functions of Controls 20</p> <p>Basic Saw Operations 23</p> <p>Adjustments to Compensate for Wear 28</p> <p>Trouble-Shooting 31</p> <p>Maintenance and Lubrication 34</p> <p>Recommended Accessories 34</p> <p>Repair Parts 35</p>
--	--

assembly and alignment

TOOLS NEEDED

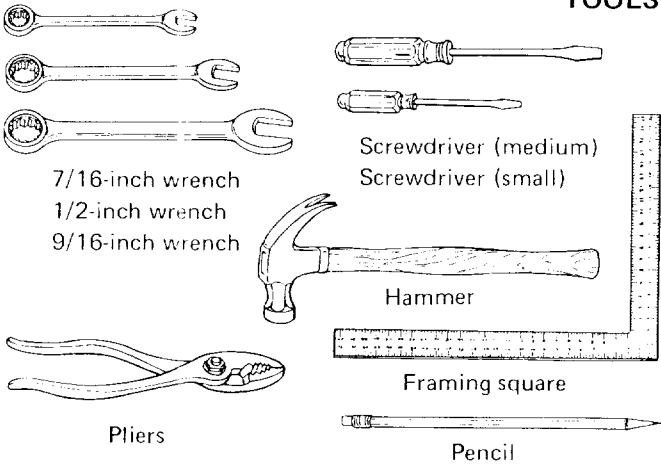

UNPACKING AND PREASSEMBLY

WARNING: DO NOT CONNECT THE POWER CORD TO A SOURCE OF POWER. THIS CORD MUST REMAIN UNPLUGGED WHENEVER YOU ARE WORKING ON THE SAW.

Model 113.19770 Radial Saw is shipped complete in one carton but **DOES NOT INCLUDE** Steel Legs.

Model 113.197750 Radial Saw is shipped complete in one carton but **INCLUDES** Steel Legs.

1. Unpacking and Checking Contents

Separate all "loose" parts from packaging materials and check each item with "Table of Loose Parts" to make sure all items are accounted for, before discarding any packing material.

If any parts are missing, do not attempt to assemble radial saw, plug in the power cord, or turn the switch

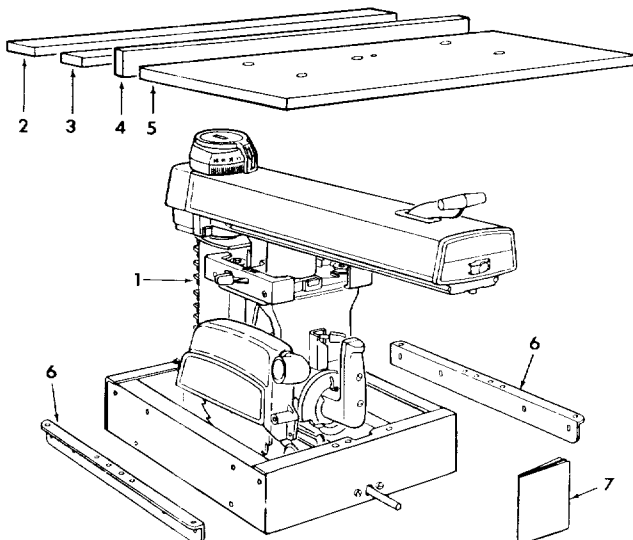

FRAMING SQUARE MUST BE TRUE

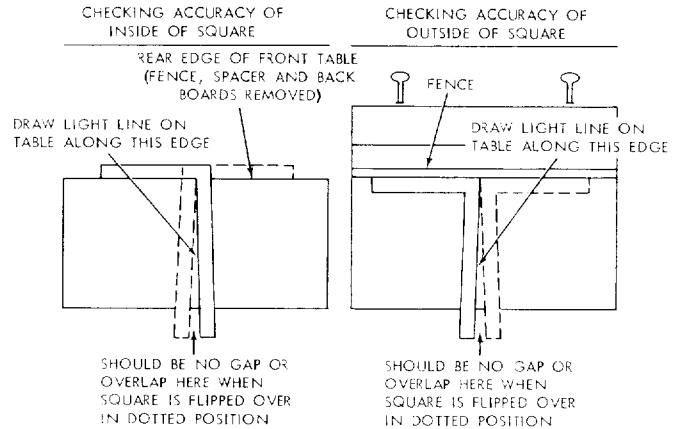

on until the missing parts are obtained and are installed correctly.

Key No.	Table of Loose Parts	Qty.
1	Basic Saw assembly	1
2	Rear table	1
3	Table spacer	1
4	Rip fence	1
5	Front table	1
6	Channel, Table Mtg.	2
7	"Owner's Manual"	1
	Loose Parts Carton Part No. 63678 (containing the following items):	
	– Hex "L" Wrench, 1/8"	1
	– Switch Key	2
	– Rip-Scale Indicator	2
	– Twin Nut (for attaching rip-scale indicator) ..	2
	– Machine screw, pan-hd., 1/4-20 x 1"	4
	– Washer, steel (Flat), 17/64 x 5/8 x 1/32"	5
	– Machine screw, pan-hd., 6-32 x 7/16"	4
	– Lockwasher, 5/16	4
	– Washer, Flat, 11/32 x 7/8 x 1/16	4
	– Nut – "T"	1
	– Set Screw, Cup.Pt. 1/4-20 x 1	1
	– Screw Pan Head, 1/4-20 x 1-3/4	1
	– Nut Hex 1/4-20	4
	– Lockwasher 1/4	4
	– Nut Lock 5/16-18	2
	– Bolt Sq. Hd. 5/16-18 x 3/4	4
	– Washer 21/64 x 9/16 x 1/16	2
	* Loose Parts Bag Part No. 63677 (containing the following items):	
	– Hex "L" Wrench, 1/4	1
	– Hex "L" Wrench, 3/16	1
	– Elevation crank assembly	1
	– Arbor Wrench	1
	– Table Clamp	2
	– Shaft Wrench	1
	– Nut, Hex 5/16-18	4



The following parts are included with Model 113.197750.

Key No.	Table of Loose Parts	Qty.
1	Leg	4
2	Stiffener, L.H.	4
3	Stiffener, R.H.	4
Loose Parts Bag Part No. 63752 (containing the following items):		
4	- Screw, Truss Hd. 1/4-20 x 5/8	40
5	- Lockwasher, 1/4 External	40
5	- Lockwasher, 5/16 External	8
6	- Nut, Hex 1/4-20	40
6	- Nut, Hex Jam 5/16-18	8
6	- Nut, Hex 1/2-13	8
7	- Foot, Leveling	4
8	- Screw, Hex Hd. 5/16-18 x 5/8	8
9	- Washer, 11/32 x 11/16 x 1/16	16

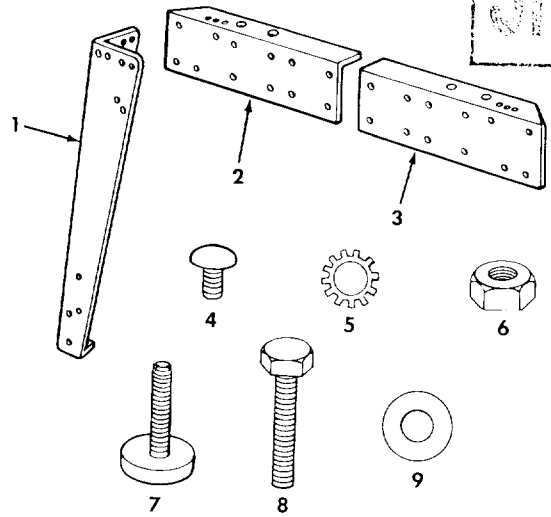

ASSEMBLING STEEL LEGS

NOTE: Steel Legs are furnished with Model 113.197750. From among the loose parts, find the following Hardware:

- 40 Truss Head Screws, 1/4-20 x 5/8
- 40 Lockwashers, 1/4-External
- 40 Hex Nuts, 1/4-20
- 8 Hex Nuts, 1/2-13
- 4 Leveling Feet

Assemble the Legs as shown.

1. Assemble Two (2) each of right and left hand Stiffeners to the length shown using 1/4-20 x 5/8" truss head screws, lockwashers and hex nuts.
2. Attach the four (4) legs to the Stiffeners using 1/4-20 screws, lockwashers and nuts.
3. Install leveling feet as shown. To level steel legs, loosen nut on inside of leg and turn nut on outside to raise or lower feet. Adjust all four levelers if necessary, and then tighten nuts on inside of leg.

NOTE: These levelers are not intended for height adjustment.

CAUTION: Leveling feet must be adjusted so the saw does not rock **AND** so that the arm slopes slightly downward to the rear so the carriage will not roll forward due to gravity.

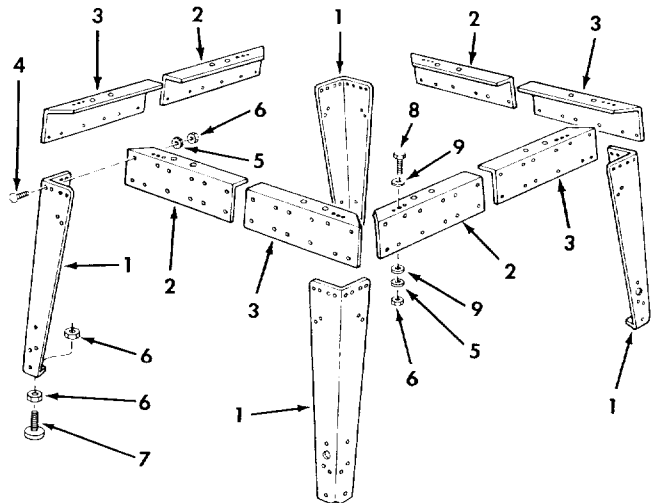
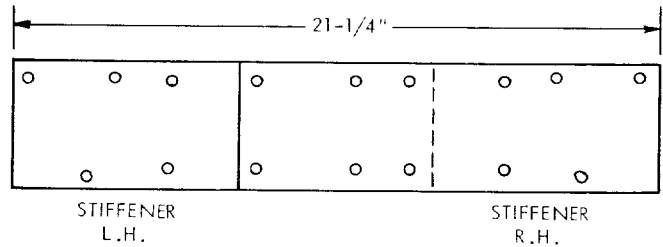
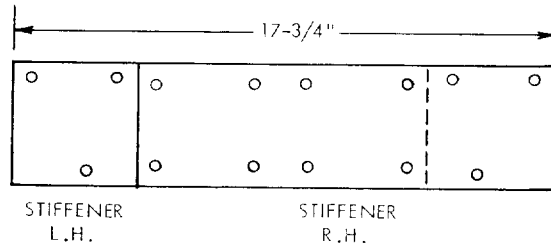

REMOVE SKIDS FROM BASE

MOUNTING SAW

1. From among the loose parts, find the following hardware:
 - 8 Hex Head Screws, 5/16-18 x 5/8
 - 8 Lockwashers, 5/16 in. External Type
 - 16 Washers, 11/32 ID
 - 8 Hex Jam Nuts, 5/16-18
2. Place saw on legs so that holes in bottom of saw line up with holes marked X in top of legs.
3. Install screws, washers and nuts as shown.

If you mount the saw on any other Craftsman base or flat bench, make sure Elevation Crank has proper clearance to rotate. The saw must be bolted down. Position saw to slope slightly rearward, so when the carriage is installed it will not roll forward due to gravity.

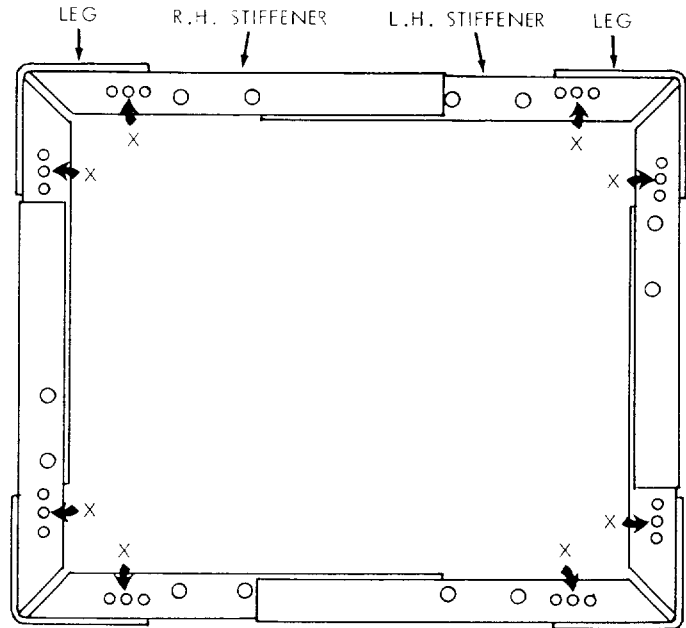
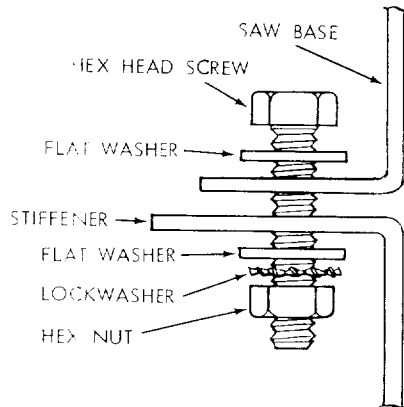

ATTACH ELEVATION CRANK.

Be sure setscrew is tightened on flat of shaft.

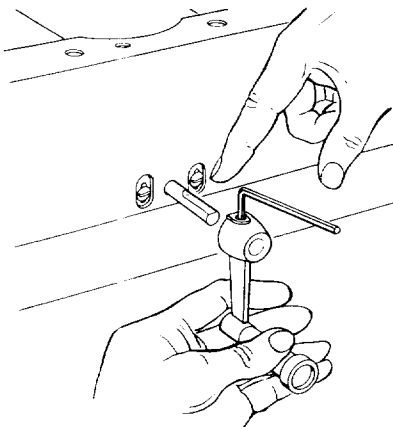

ELEVATE ARM TO ITS MAXIMUM HEIGHT.

Remove shipping block and discard.

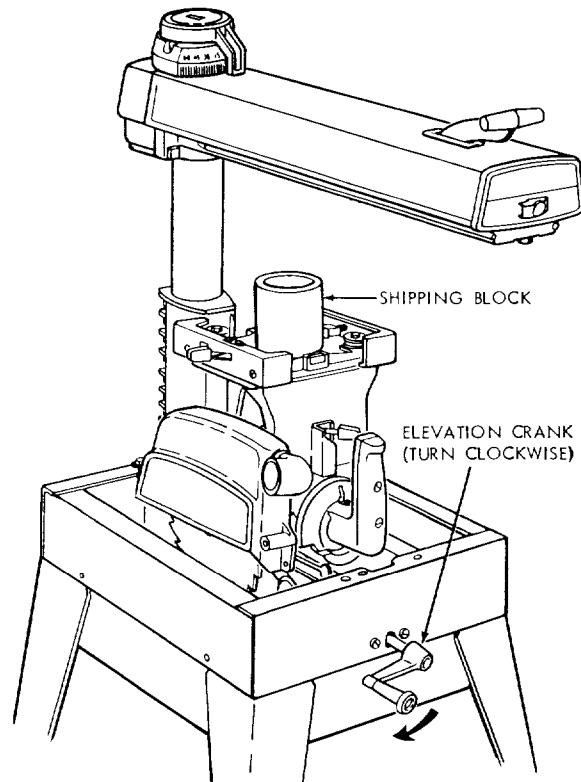

assembly and alignment

BE positive switch is "OFF" and power cord unplugged thru-out entire procedure.

REMOVE CARRIAGE STOP SCREW, LOCKWASHER AND TAG. Read and understand warning tag before discarding.

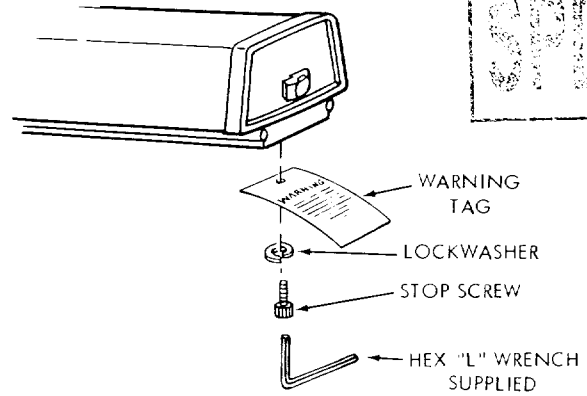

LOCK ARM BEFORE PROCEEDING.

HOLDING CARRIAGE ASSEMBLY WITH BOTH HANDS, CAREFULLY START AND SLIDE THE CARRIAGE ONTO THE TRACKS. The assembly must be held parallel with the arm so that all four bearings slide smoothly onto the arm, preventing any excessive strain on bearings and track.

WARNING: REINSTALL CARRIAGE STOP SCREW TO PREVENT CARRIAGE FROM ROLLING OFF ARM.

Check for looseness of carriage bearings. Refer to "Adjusting Carriage Bearings" in "Adjustments to Compensate for Wear" Section.

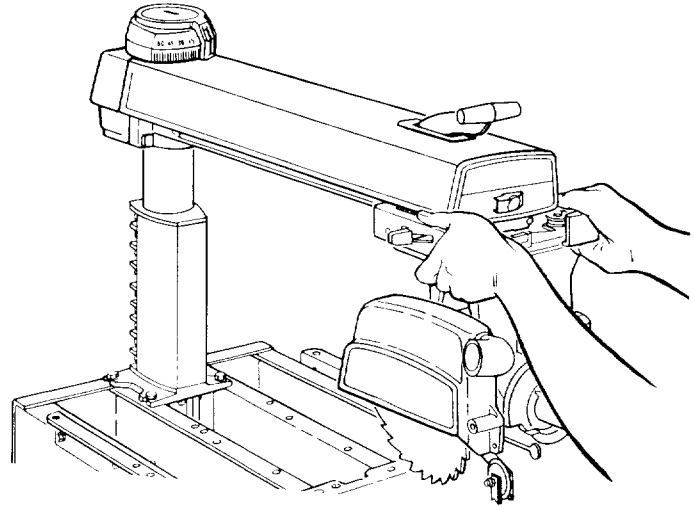

REMOVE SHIPPING SCREWS AND DISCARD.

Use of pliers may be necessary.

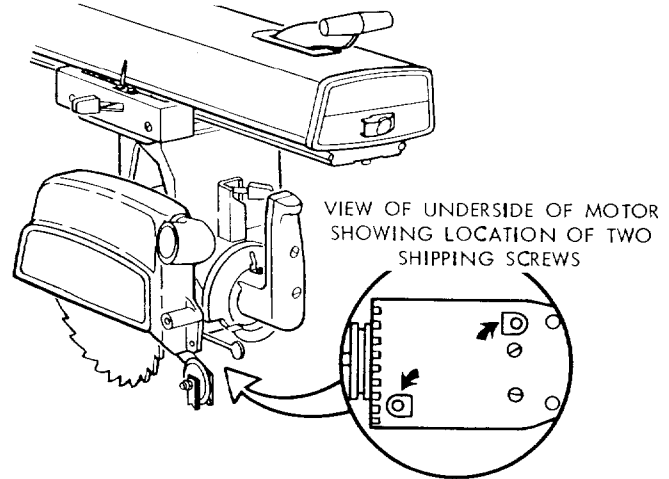

REMOVE SAW BLADE.

1. Tighten carriage lock knob.
2. Loosen guard clamp screw, remove guard.
3. Motor shaft has left hand threads. Hold shaft wrench and rotate arbor wrench down (clockwise).
4. Remove shaft nut, outer collar, saw blade, and inner collar. Set aside and out of the way.

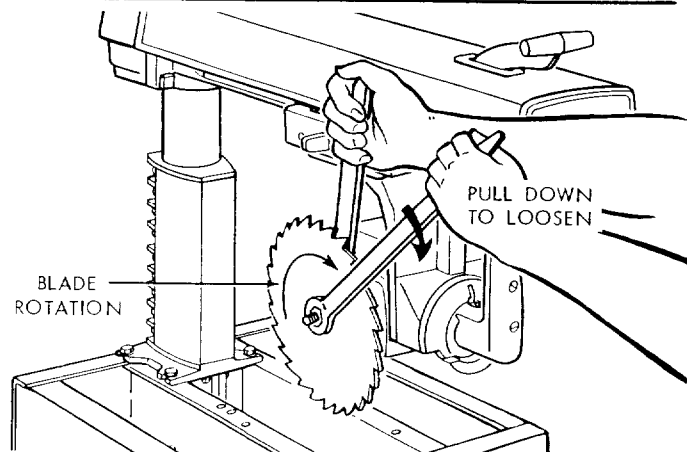

ALIGNMENT PROCEDURE

IMPORTANT:

IN ORDER TO OBTAIN MAXIMUM CUTTING ACCURACY, THE FOLLOWING SIX STEPS MUST BE CAREFULLY FOLLOWED. BECOME THOROUGHLY FAMILIAR WITH THESE STEPS SO THAT YOU CAN ALWAYS MAINTAIN YOUR SAW IN PROPER ALIGNMENT. THE ACCURACY OF EACH ADJUSTMENT IS ALWAYS DEPENDENT UPON THE ACCURACY OF THE PRECEDING ADJUSTMENT.

After following the 6 step assembly and alignment procedure and the Basic Saw operation section refer to Trouble Shooting section if any difficulty is experienced when performing any sawing operation.

STEP ONE

NOTE: The following adjustment, performed properly, will result in the work table being parallel to the arm.

ATTACHING AND LEVELING TABLE MOUNTING SUPPORT CHANNELS.

1. Attach table mounting support channels with four square head 5/16-18 x 3/4 screws, lockwashers and flat washers and nuts. POSITION SCREWS IN CENTER OF CHANNEL SLOTS, finger tight to permit channels to "slip" against the base when leveling.

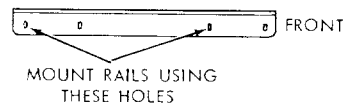
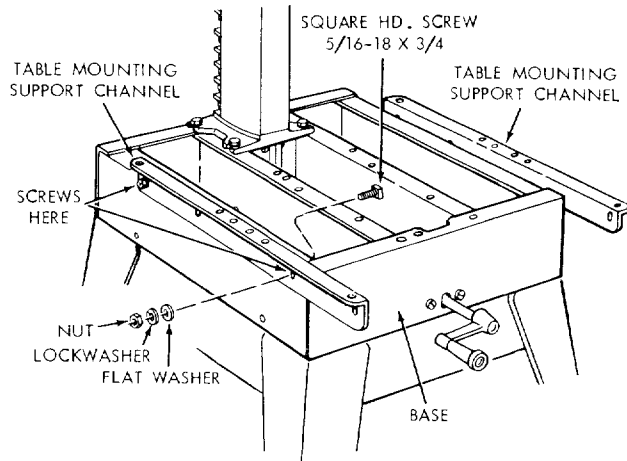

2. Release bevel lock lever, move bevel index pin to left and rotate the motor to position saw blade, end of shaft down. Lock bevel lock.
3. Unlock and hold arm control lever in index release position as shown. Position arm against left stop (approximately 50° miter). Loosen carriage lock knob and position carriage directly over left hand channel.

NOTE: For safety reasons in accordance with the UL standard, stops have been provided to prevent 360° rotation of the radial arm.

4. Slide the arbor wrench handle between end of motor shaft and mounting channel to act as a feeler gauge. Carefully lower the motor with elevation crank until the end of shaft is just touching the arbor wrench. The wrench should slide back and forth with only slight resistance. Tighten screw "A".

NOTE: Do not change this elevation setting until both left and right hand table support channels have been adjusted.

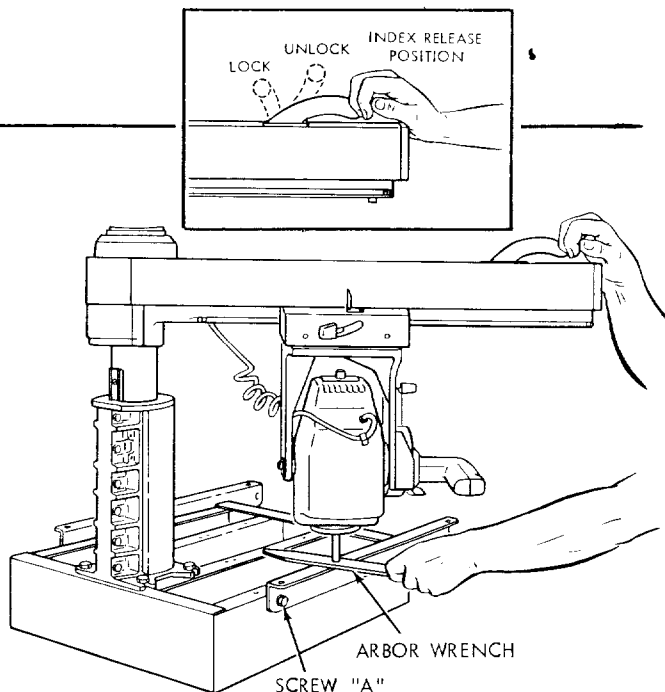

5. Move arm and carriage to screw "B" and tighten support in the same manner.
6. Move arm and carriage to right hand support channel and level in the same manner you adjusted the left hand support channel.
7. Recheck both support channels to make sure that tightening screws did not affect the accuracy of the adjustment.
8. Elevate saw and place motor in vertical position to provide clearance for installation of front (work) table.

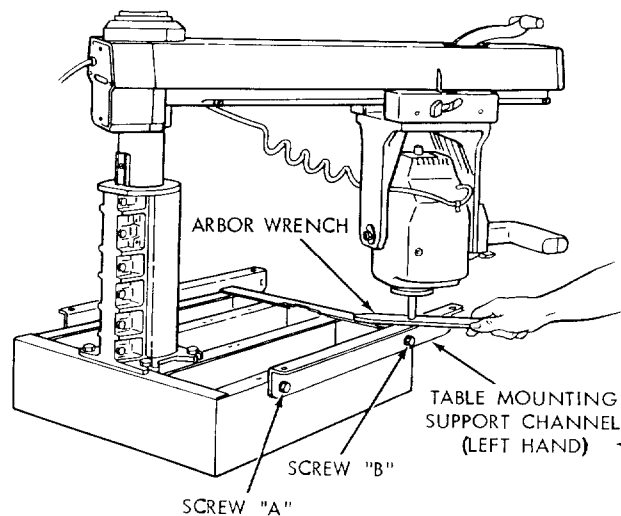

assembly and alignment

INSTALLATION OF FRONT (WORK) TABLE.

1. Place front table board upside down on a workbench or on the floor. Drive T-nut into the hole that is not counterbored.
2. Align the counterbored holes with matching holes in support channels. Install the five 17/64 inch flat washers, and four 1/4 - 20 x 1 inch Pan-Head machine screws. Just barely start the cup point set screw and the one (1) 1/4 - 20 x 1-3/4 inch Pan Head machine screw in table center holes.
3. Install one 1/4 lockwasher and Hex Nut on each of the four (4) screws in the support channels and tighten.

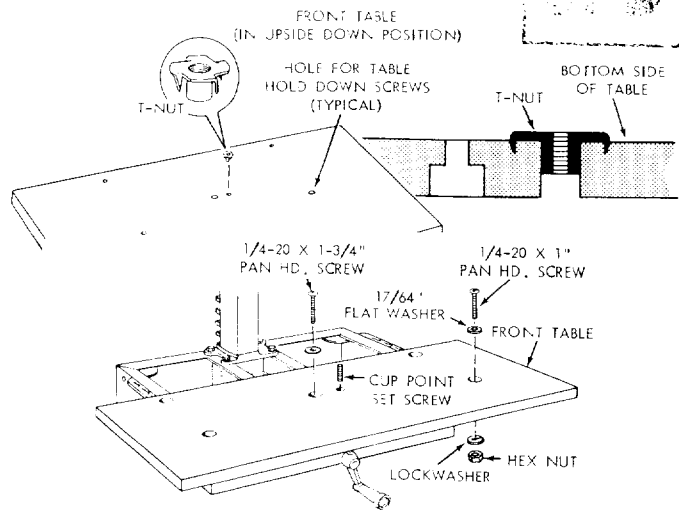

4. Lay the rear table board on edge across the front table to serve as a straightedge. Sight under this straightedge to determine whether the front table board is high or low at its center.
5. If the front table is high at center, first tighten the center (1/4 - 20 x 1-3/4 inch) hold down screw until the table is level - then tighten the leveling screw until this screw is snug.

If table is low at center, first tighten the leveling screw until the table is level - then tighten the hold down screw.

If table is not high or low, tighten leveling screw and center hold down screw snug.

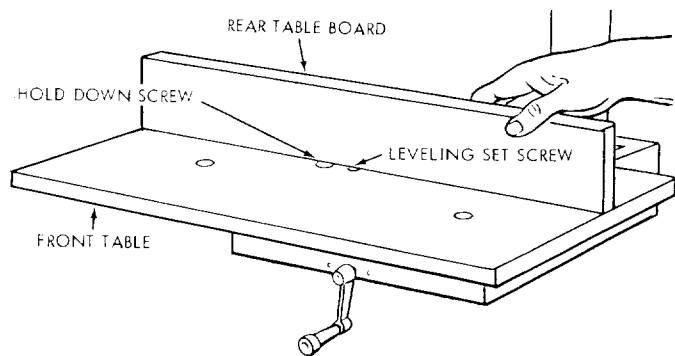

STEP TWO

ADJUSTING COLUMN TUBE IN COLUMN SUPPORT

NOTE: The following adjustment is very **CRITICAL**. All future alignment procedures rely on this adjustment being performed correctly. **ALL LOOSENESS MUST BE REMOVED.**

1. Index and lock arm at 0° Miter.

While holding the arm with one hand, hold fingers of other hand as shown, between column tube and column support. Apply gentle side pressure to the arm in opposing directions. Any side to side or rotational movement (indicated by arrow) can be felt with finger.

If looseness exists the following adjustments are required.

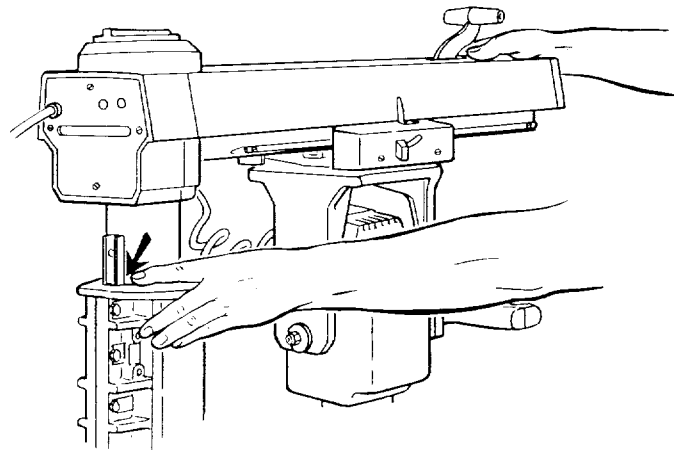

2. Remove Column Support trim using screwdriver as shown.

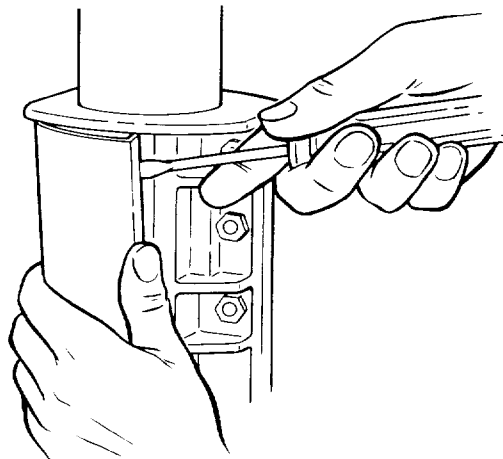

- Loosen (2) $\frac{1}{4}$ - 20 Gib set screws on the left side at the rear of the column support.

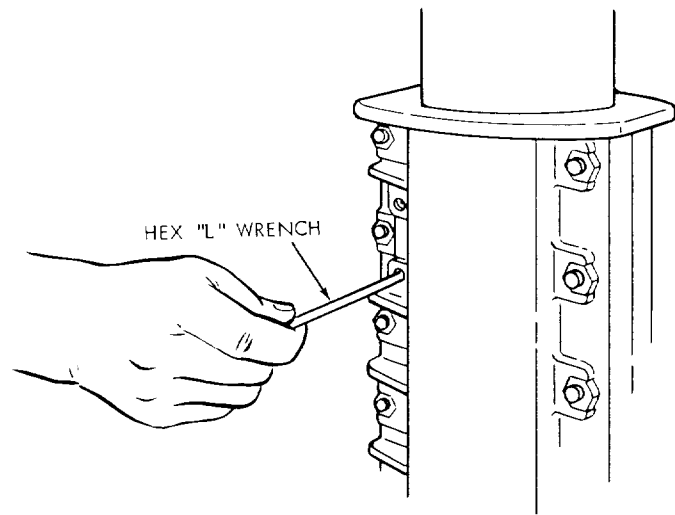

- Elevate, and then lower the Arm: (a) if the column binds and elevation is difficult loosen two $\frac{5}{16}$ - 18 plated nuts on front side of the column support until you achieve smooth but firm elevation. (b) If the column moves side-to-side within the column support, tighten the two $\frac{5}{16}$ - 18 plated nuts until movement disappears - elevation should be smooth and firm.
- Now tighten the (2) $\frac{1}{4}$ - 20 Gib set screws until no noticeable rotational play exists between Column Tube and Column Support.
- Recheck elevation and re-adjust if necessary.
- Replace Column Support trim.

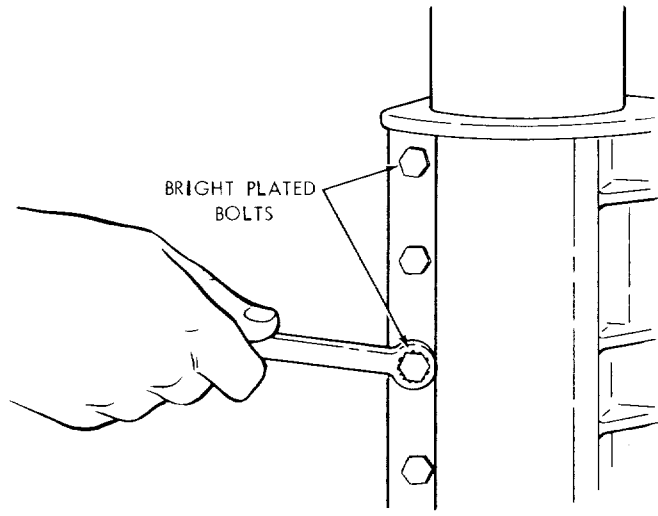

STEP THREE

SQUARING CROSS CUT TRAVEL (CARRIAGE TRAVELS IN A STRAIGHT LINE).

- Index but do not lock arm at 0° miter.
- Install saw blade as shown. Motor shaft has left hand threads.

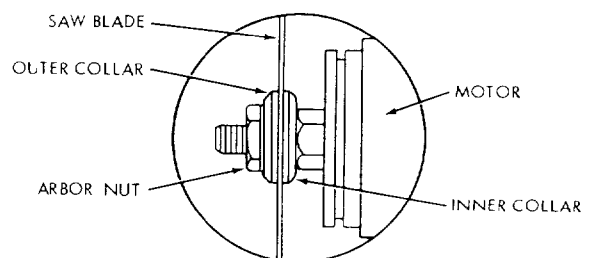
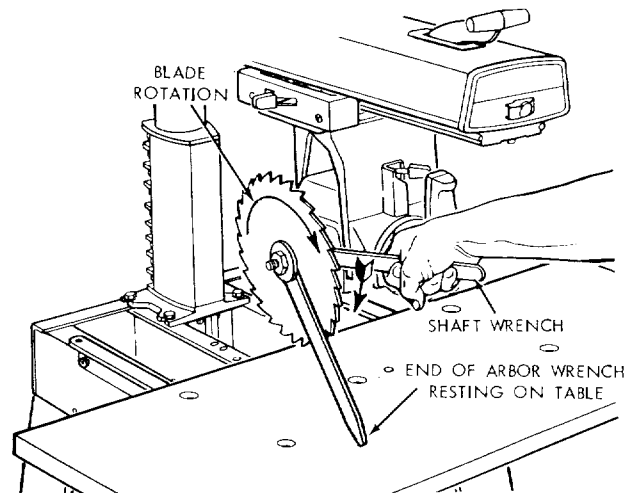

assembly and alignment

3. Lower arm until saw blade just clears the front table. Lock the yoke clamp handle and bevel lock lever.
4. Place a framing square on the table as shown and position the blade and square until the leg of the square just contacts a tooth of the blade. Mark this tooth.

NOTE: The framing (or combination) square must be "true" — see start of "Assembly and Alignment" section on p. 8 for checking method."

5. When the carriage is moved back and forth on the arm, the marked tooth should just touch the square at all points. If marked tooth moves into square or away from square the following adjustments are required:

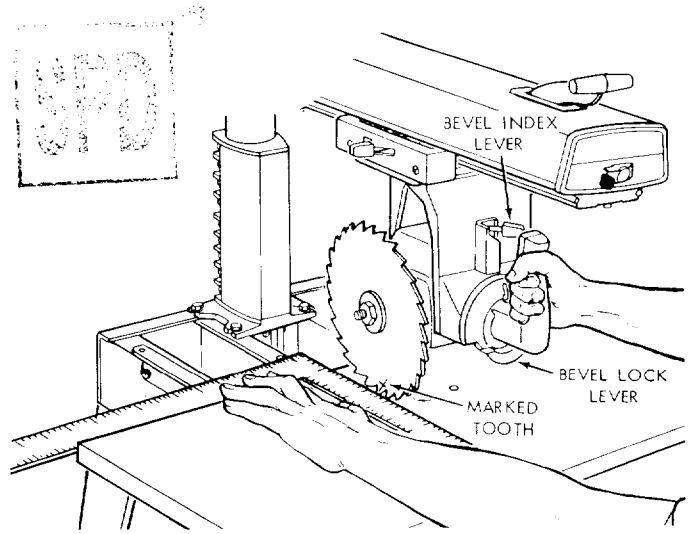

- a. Loosen (3) 3/8 — 16 set screws in arm latch at rear of arm.
- b. Move the arm in proper direction to make marked tooth follow edge of square when the saw blade is moved along arm in a "cross cut" manner.
- c. Lock arm latch.
- d. **RETIGHTEN** (3) setscrews in arm latch as tight as possible and recheck "cross cut" travel.

NOTE: This squaring of the cross cut travel will simultaneously set BOTH of the 45° miter index positions.

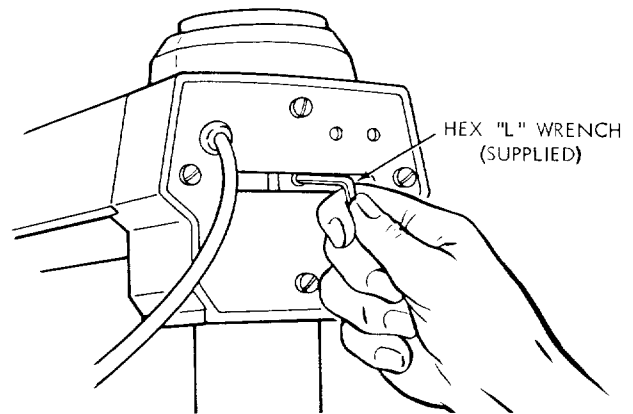

- e. Set miter indicator on 0° position as shown.

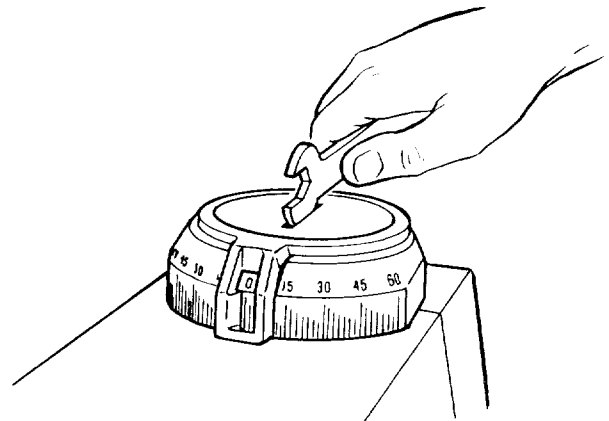

6. Position the rip (guide) fence, spacer board and rear table board behind the front table board as shown.
7. Install the two table clamps in the holes provided for them at the rear of the saw base, and tighten them securely.

NOTE: The life of your saw table will be lengthened considerably if you will cover the front table with a fitted piece of 1/4 inch plywood. This should be tacked in place for easy replacement. Use of such a cover will allow you to do all cutting into the cover, rather than your table top.

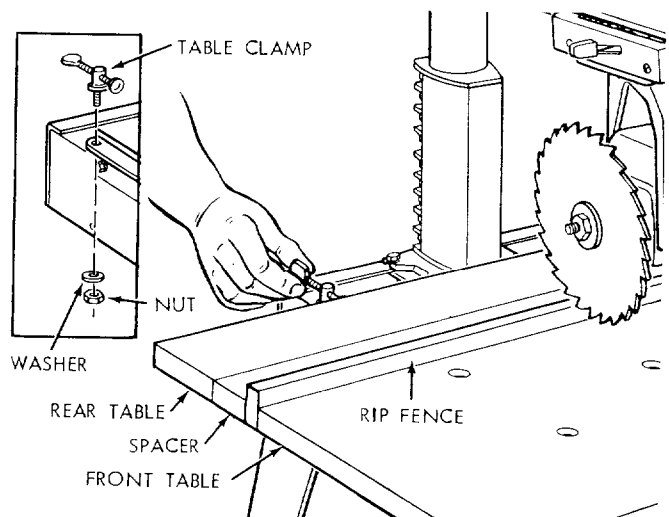

STEP FOUR

SQUARING SAW BLADE TO (WORK) TABLE

NOTE: If alignment procedure step one was not performed, this adjustment can not be accomplished.

1. Place a framing square on the table with the short leg against the saw blade. Do not allow the square to rest against a "set-out" tooth; it must rest flat against the blade side.
2. If the saw blade is square with the table top (no visible gap appears between the saw blade and square) and no adjustment is required. Set bevel indicator to 0° reading. If the square does not touch the saw blade as shown (with square leg held firm against the table top), perform the following adjustments:

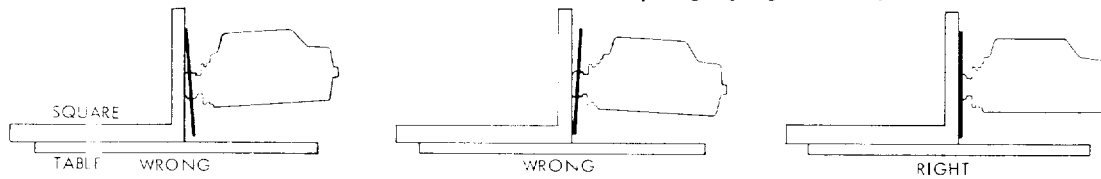
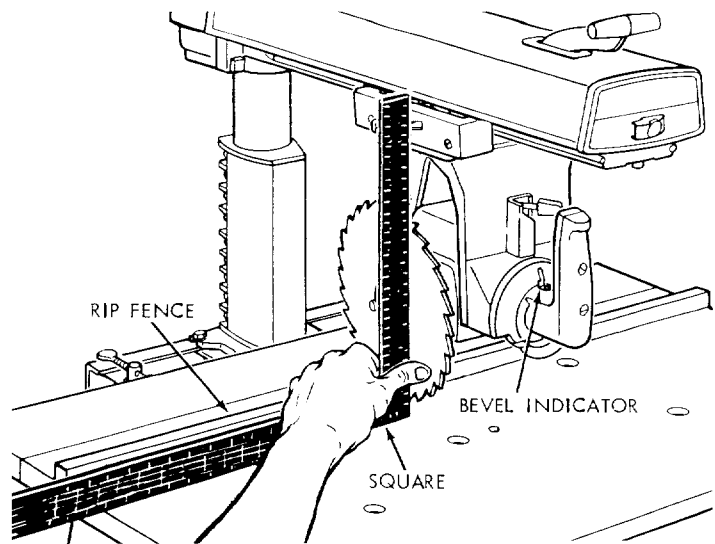

- a. Tighten carriage lock knob.
- b. Remove handle cover by removing two #10 Pan Head Screws. Remove handle by removing 5/16-18 socket head screw and lockwasher.
- c. Loosen the four socket head screws with 1/4" Hex "L" Wrench. Rotate motor while holding square firmly against saw blade and table top.
- d. Slightly tighten each of the four screws and recheck . . . Now tighten each screw tight.
- e. Reinstall handle and adjust indicator on 0° reading.
- f. Loosen carriage lock knob.

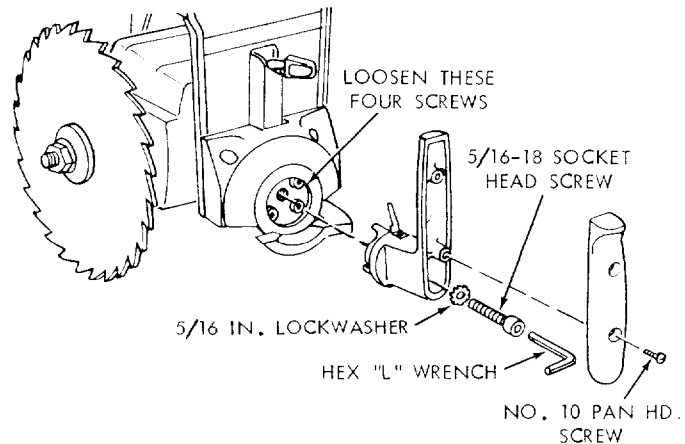

STEP FIVE

SQUARING BLADE TO RIP (GUIDE) FENCE – BLADE HEEL ADJUSTMENT.

NOTE: If alignment procedure steps two and four were not performed, this alignment step cannot be accomplished.

1. Position carriage as shown and tighten carriage lock knob. Place a framing square against the rip fence and the saw blade, as shown. The long leg of the square must be held firmly against both the fence and the table top, and the short leg must not touch any of the teeth on the saw blade. Check at several points of blade rotation.
2. If the square does not touch the blade at both of the two points as shown, a heel condition exists.

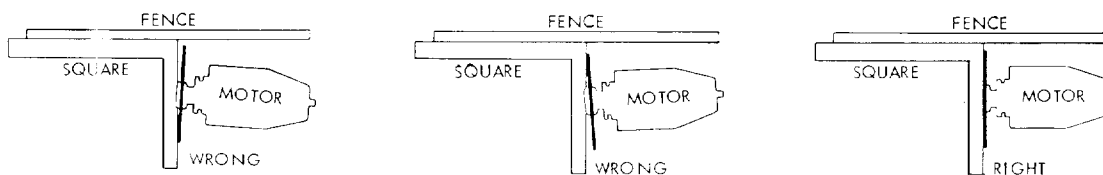
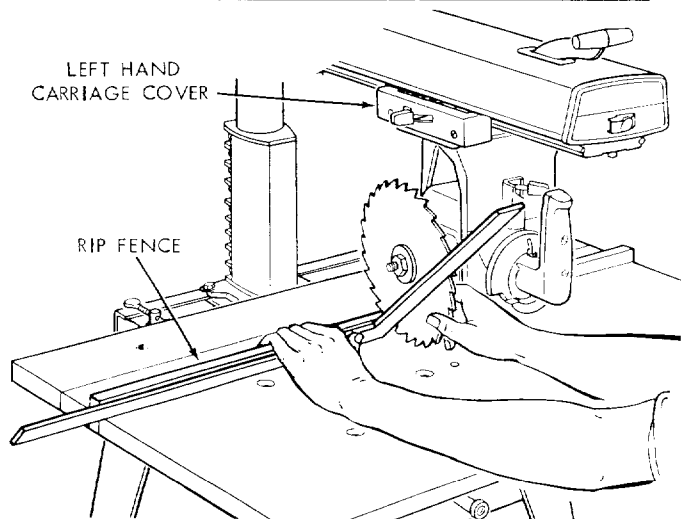

assembly and alignment

3. To correct "heel" condition proceed as follows:
 - a. Remove left hand carriage cover.
 - b. Loosen the yoke clamp handle.
 - c. Loosen (slightly) the two hex-head screws.
 - d. Rotate the yoke assembly until gap between the saw blade and square is eliminated.
 - e. Lock yoke clamp handle and retighten the two hex-head screws.
 - f. Recheck for "heel" and install carriage cover.
 - g. Loosen carriage lock knob.

NOTE: This alignment procedure will simultaneously set both yoke indexing positions for blade in and out rip.

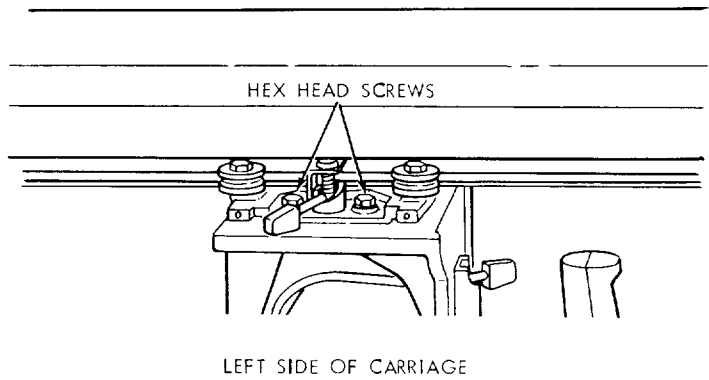

VERTICAL HEEL ADJUSTMENT

1. With sawblade in 90° cutoff position, elevate saw and rotate motor to vertical position (Blade Horizontal) and check for heel. Make sure bevel lock lever is locked.
2. Position square perpendicular to fence and between blade and table, as shown lower arm. Do not allow the square to rest against a "set-out" tooth, it must rest flat against the blade side.

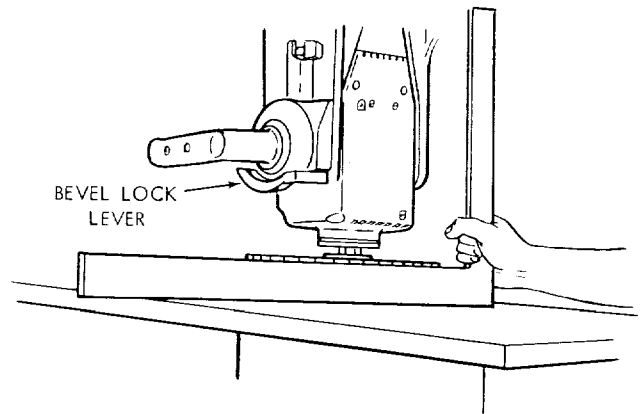

3. If the saw blade is parallel with the table top (no visible gap appears between the saw blade and square), no adjustment is required.
4. If there is a visible gap between saw blade and square, a bevel heel condition exists and adjustment is required.
 - a. To correct, unlock bevel lock lever, loosen the rear motor mount 3/8-16 nut until you can rotate Cam, and then rotate Cam as shown until gap between saw blade and square is eliminated.
 - b. Tighten nut and bevel lock lever and recheck.
 - c. Reposition motor in crosscut position.

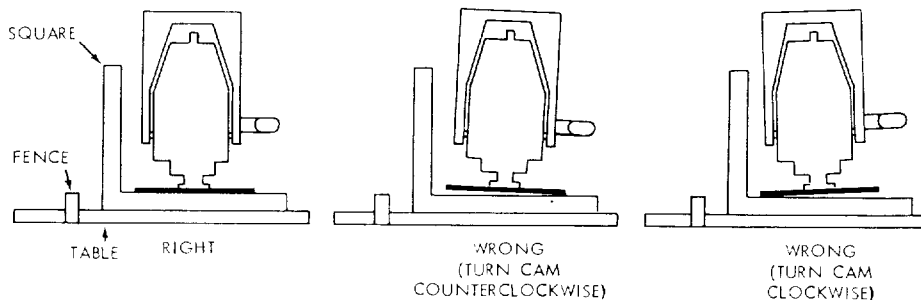
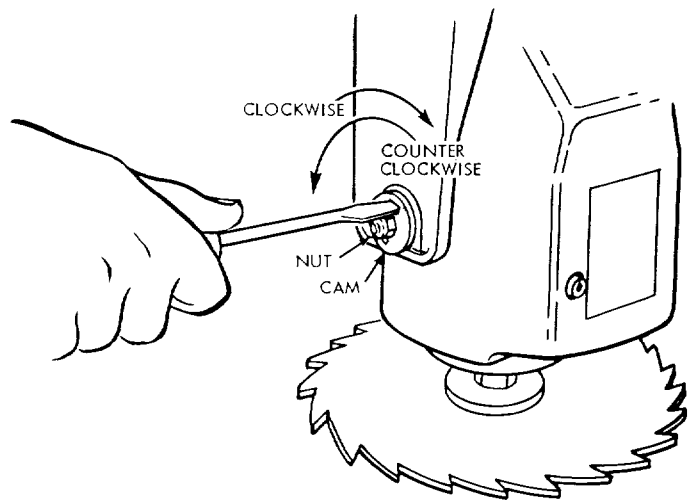

STEP SIX

1. INSTALLING AND ADJUSTING RIP SCALE INDICATORS.

NOTE: The rip scales and pointers are intended to be used for quick settings. For greater accuracy, take direct measurement between blade and fence.

- Pre-assemble indicator and twin nut, loosen but do not remove the two screws which attach left hand carriage cover.
- Tilt carriage cover and install rip indicator as shown. Tighten carriage attaching screws.
- Loosen but do not remove carriage lock knob in right hand carriage cover. Install rip indicator in the same manner. Tighten carriage attaching screws.

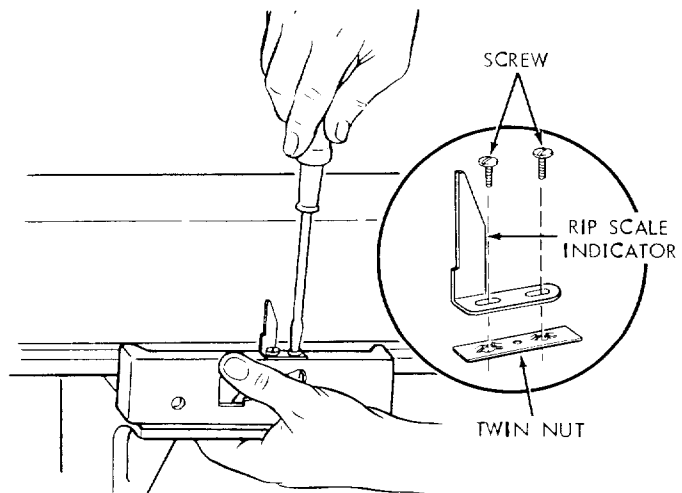

- With the fence in its normal position (next to the front table), loosen the yoke clamp handle, pull on swivel latch pin knob and rotate the yoke as shown to index the yoke 90° from the cross cut position. This will locate the saw blade and the fence. Lock the yoke by tightening the yoke clamp handle.

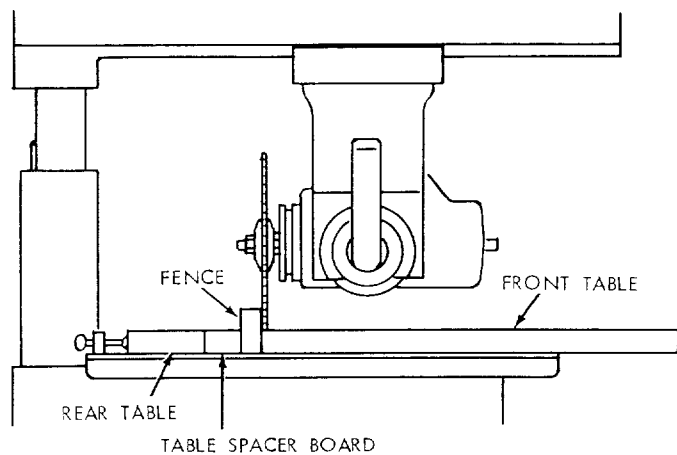

- Position carriage until the edge of the blade, when spun by hand, just touches the front face of the fence. The rip-scale indicator (on the right hand side of radial arm) should now read "0" inches on upper portion of the blade "In-Rip" scale. If not, loosen screws and shift the indicator until it is aligned with the "0" mark, then tighten the screws.

NOTE: With the saw blade and fence in the position shown, the upper portion of the blade "In-Rip" scale is used. If the fence is re-located at the extreme rear position, the lower portion of the blade "In-Rip" scale would be used.

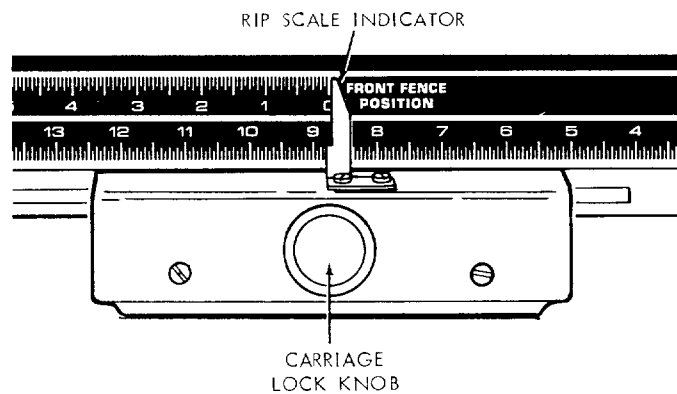

- The blade "Out-Rip" scale indicator on the left hand side of the radial arm is adjusted in essentially the same manner as the blade "In-Rip" indicator, except the blade should be as shown. With 2 inches measured between the fence and the face of saw blade, the rip-scale indicator should be positioned to read 2 inches on the upper portion of the blade "Out-Rip" scale.

NOTE: With the saw blade and fence in the position shown, the upper portion of the blade "Out-Rip" scale is used. If the fence is moved to rear position (at the rear of rear table) the lower portion of the blade "Out-Rip" scale is used.

- Loosen the yoke clamp handle, pull on the swivel latch pin knob and return the blade to the 90° position.

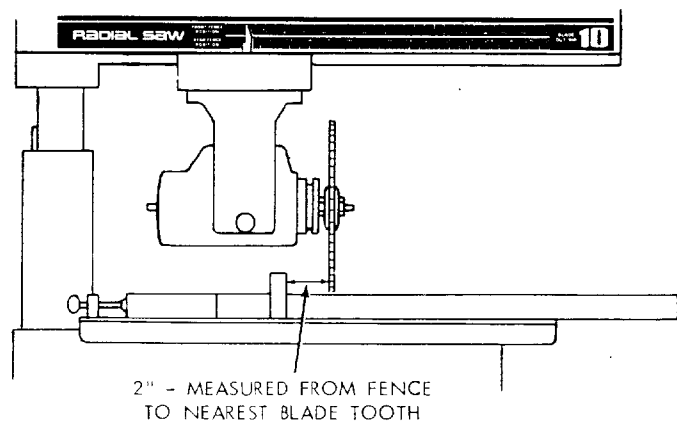

assembly and alignment

ALIGNMENT OF SPREADER FOR RIPPING.

WARNING: NEVER POSITION THE GUARD OR ANTIKICKBACK ASSEMBLY WITH POWER ON; NOR POSITION ANTIKICKBACK PAWLS BY GRASPING PAWLS OR SPREADER.

2. Install Blade Guard.

- a. Sight (visually) to check for proper alignment of spreader with saw blade as shown. If the spreader is not aligned, adjust it as follows:
 - (1) Loosen two hex nuts, one on each side of spreader.
 - (2) Rotate hex nuts with fingers until the spreader is directly in line with saw blade.
 - (3) Tighten both hex nuts firmly.

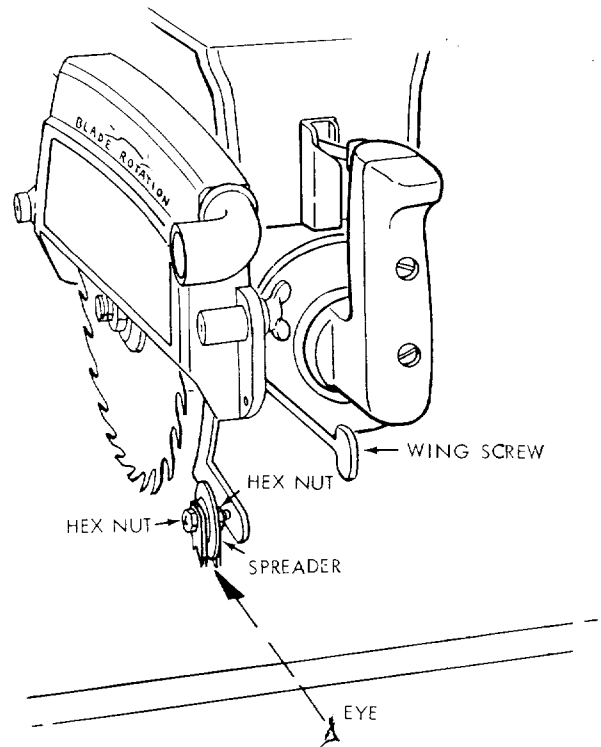

3. Check and Adjust the spreader as follows:

- a. Loosen the antikickback spreader adjusting wing screw and with the "tab" position the antikickback and spreader assembly near the bottom of the blade and tighten.

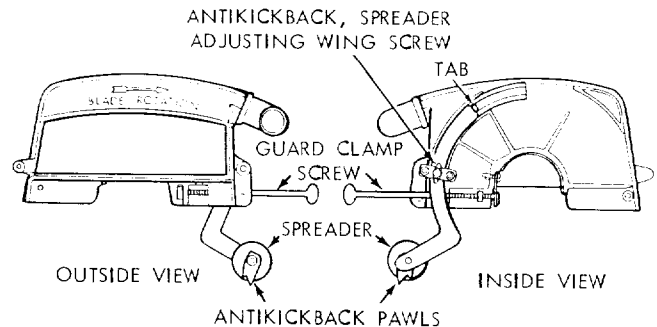

FENCE LOCATIONS

Position (A) is used for most cutoff and narrow ripping operations. Position (B) is used for maximum width ripping. Position (C) is used to achieve maximum crosscut capacity in thin work.

Now that you have assembled and aligned your saw, you are ready to proceed with operating controls section of this manual. Refer to trouble shooting section if saw does not perform satisfactorily or any problems should surface after using the saw.

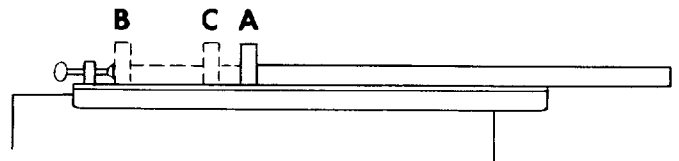

locations and functions of controls

The versatility of the Radial Saw is due, in part, to its controls, and these are the keys to its successful operation. Learn to use the controls for all operations before actually starting to saw.

A series of six diagrams is located on the top surface of the arm. These designate the controls that must be used in basic set-ups and operating procedures. You should become familiar with these diagrams and the operating instructions that follow, before operating your saw.

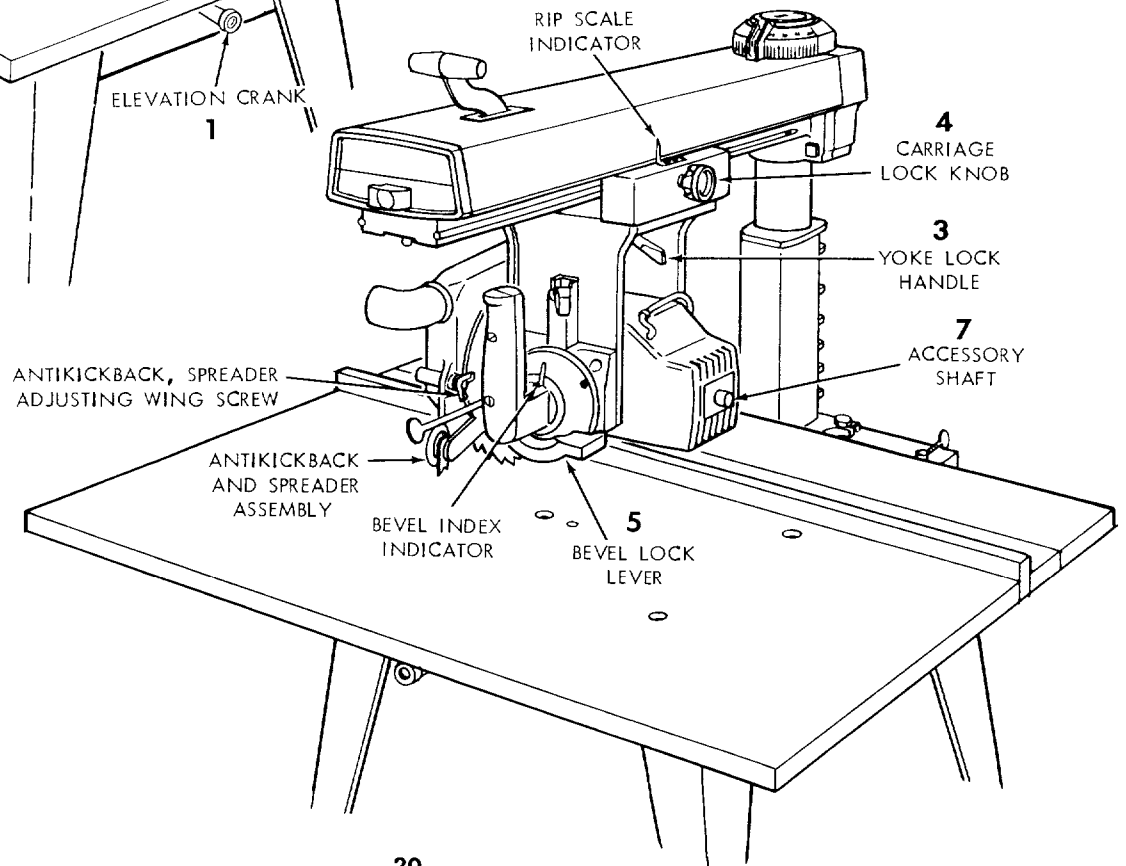
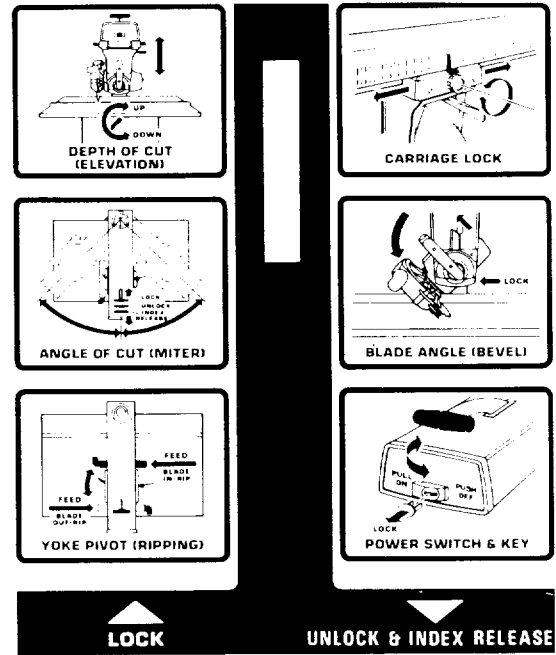
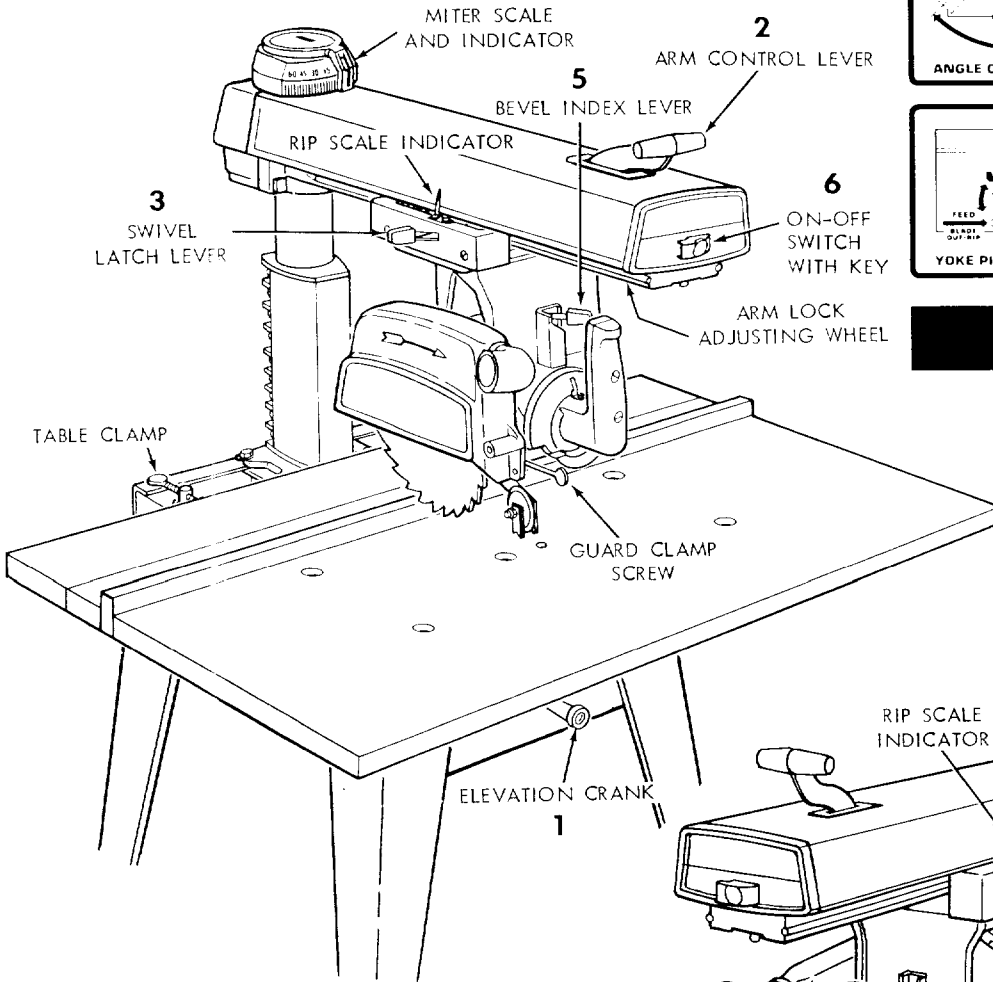

locations and functions of controls

1. Depth of Cut (Elevation)

- The diagram shows the elevation crank which is used to raise and lower the saw blade.
- Clockwise rotation raises the blade counterclockwise rotation lowers it. One complete turn of the handle will raise or lower the saw blade 1/16-inch.

2. Angle of Cut (Miter)

Proper Indexing Method — Experienced operators of woodworking equipment, such as this Craftsman Radial Saw, acquire the habit of indexing in one direction only, whenever a new setting is made in preparation for a different operation.

Example: When moving the arm to a miter index position move it slightly past the desired index position, then return to the index position carefully to index and lock. Yoke indexing and bevel indexing can be accomplished in a similar manner. This indexing technique tends to neutralize any stresses imparted upon saw components and contributes to the high degree of accuracy the saw is capable of producing when operated expertly.

- The arm control lever locks, unlocks and indexes the arm for Left and Right Miter cuts.
- The radial arm has positive index positions at 0° and 45° Left and Right. The arm is rotated by pulling arm control lever to index release position. With arm control lever released the arm will automatically index at 0° and 45° Left or Right. After positioning arm to the desired miter angle, push arm control lever to locked position.

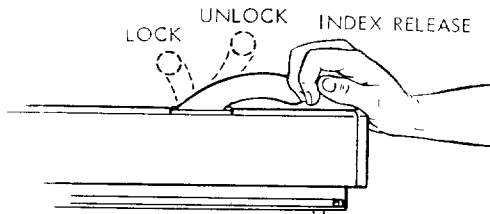

3. Yoke Pivot (Ripping)

- Two controls are used in this operation. They are: the swivel latch-pin lever and the yoke clamp handle.
- A swivel latch lever automatically indexes the yoke at each 90° position. Pull the spring-loaded swivel latch-lever forward to release this pin.
- The yoke clamp handle locks the yoke to the carriage in any position. Pull the handle forward to release the yoke; push the handle rearward to secure the yoke.

4. Carriage Lock

- The carriage lock knob is rotated clockwise to lock the carriage on the radial arm, and counterclockwise to release it.
- When performing crosscutting operations the carriage lock knob must be rotated counterclockwise until the carriage is free to travel along the arm. This knob should be tightened until the operator is ready to grasp the bevel index handle and make a cut.

5. Blade Angle (Bevel)

- The two controls used in angular positioning and indexing of the motor, to provide the desired

saw-blade (bevel) angle, are: bevel lock lever and bevel-index lever.

- The bevel-index scale indicates the angular position of the motor with respect to horizontal, from 0° to 90° in either vertical position.
- The bevel index lever automatically indexes the motor at 0°, 45° and 90°. Move bevel index lever to the left while positioning the blade, then release it. At any other position it does not engage.
- The bevel lock lever locks the motor to the yoke when the motor is in any position. Pull lever to release and push to lock.

6. Power Switch and Key

- Insert key into switch lock.

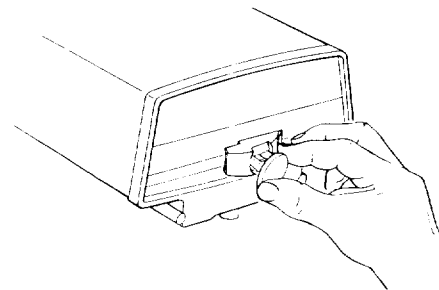

- Insert finger under end of switch lever and pull end out, to turn switch on.

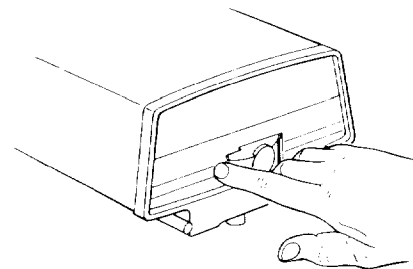

- Push lever in — with thumb — to turn switch off.

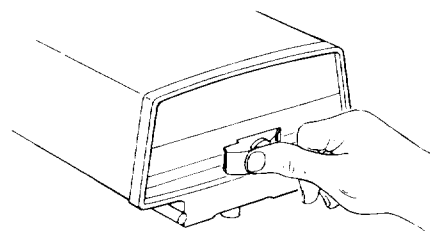

- WARNING: THIS LOCKING FEATURE IS PROVIDED TO PREVENT UNAUTHORIZED USE OF YOUR SAW. ALWAYS REMOVE THE KEY AND KEEP IT IN A SAFE PLACE. TO REMOVE KEY, HOLD THUMB ON END OF LEVER TO KEEP SWITCH IN "OFF" POSITION AND PULL KEY STRAIGHT OUT.**

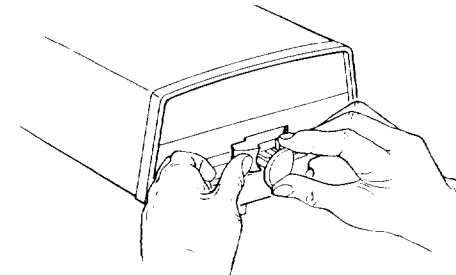

WARNING: FOR YOUR OWN SAFETY ALWAYS LOCK THE SWITCH "OFF" WHEN SAW IS NOT IN USE. REMOVE KEY AND KEEP IT IN A SAFE PLACE . . . ALSO IN THE EVENT OF A POWER FAILURE (ALL YOUR LIGHTS GO OUT) TURN SWITCH OFF. LOCK IT AND REMOVE THE KEY THIS WILL PREVENT THE SAW FROM STARTING UP AGAIN WHEN THE POWER COMES BACK ON.

7. Accessory Shaft

Use only the following recommended accessories:
Drill chuck, Sanding drum, and Router adapter.

CAUTION: The sawblade, dado, or cutting tool must be removed from the saw arbor before using the accessory shaft. NEVER operate the saw with cutting tools (including sanding accessories) installed on both ends of the saw arbor.

POSITIONING GUARD, ANTIKICKBACK AND SPREADER ASSEMBLY, FOR RIPPING

WARNING: NEVER POSITION THE GUARD OR ANTIKICKBACK ASSEMBLY WITH THE POWER ON. NEVER POSITION THE ANTIKICKBACK PAWLS BY GRASPING THE PAWLS OR SPREADER.

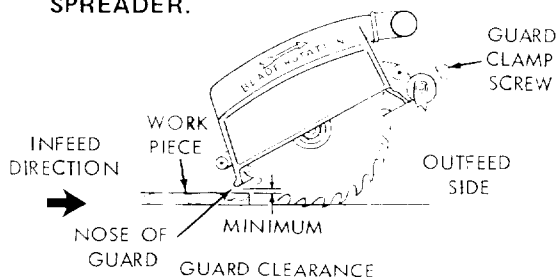

1. The blade guard is positioned by loosening the guard clamp screw and rotating the guard so that the nose just clears the workpiece as shown.

This is necessary:

- to protect operator from accidentally contacting the sawblade radially from the Infeed direction.
 - to hold down the workpiece against the table – minimizing lifting or fluttering (particularly thin and/or light workpieces);
 - to minimize sawdust thrown toward the operator.
 - to minimize the possibility of a thin pusher board riding up on top of the workpiece with loss of control of workpiece.
2. The antikickback and spreader assembly is used during ripping operations and is adjustable to accommodate the thickness of the board being ripped. A wing screw in the guard secures the assembly.

These adjustments are necessary:

Antikickback

- to stop a kickback if generated.

Spreader

- to prevent kerf from closing in on sawblade and possible kickback;
 - to prevent "wrong-way feed". "Wrong-way feed" is feeding the workpiece – when sawblade is in a rip position – into the outfeed side of the cutting tool (sawblade, dado, molding head, etc.), the side containing the antikickback/spreader. This can be extremely hazardous because the sawblade may grab the workpiece and throw it violently toward the nose of the guard (infeed side of the tool). **Danger** label on guard.
- "Wrong-way feed" occurs when the teeth themselves cut, or attempt to cut, a kerf in the workpiece. This differs from a "kickback" which is generated by the sides (one or both) of the teeth, because of binding between the fence (heel), pinching of the sides of the sawblade (failure to use spreader), and/or inadequate set of teeth of sawblade.
- to act as a partial guard regarding accidental contact with the sawblade at the outfeed side when ripping, and leading edge when crosscutting.
 - a. The blade guard is positioned by loosening the guard clamp screw and rotating the guard so that the "nose" just clears the workpiece as shown.
 - b. The antikickback and spreader assembly must be adjusted to accommodate the thickness of the board being ripped. A wing screw in the guard secures the assembly.

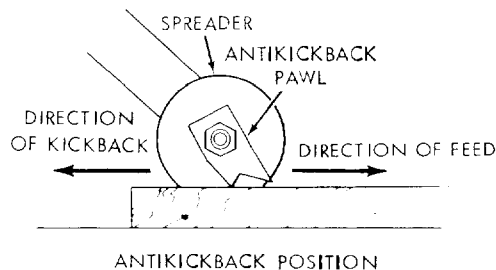

3. Loosen the wing screw and with the tab provided, position the antikickback and spreader assembly until the pawl assumes approximately the position shown above. Tighten the wing screw.

(Make sure by trial before starting the cut that the antikickback pawls will stop a kickback once it has started). Insert workpiece alongside spreader under outer set of pawls by approaching pawls in the feed direction. Push workpiece sharply in the direction of a kickback (opposite to direction of feed). Readjust Pawls if they do not stop the kickback motion by biting into the workpiece.

HAVE YOU FOLLOWED ALL SIX STEPS OF THE ALIGNMENT PROCEDURE? IF YOU HAVE NOT FOLLOWED THEM IN THEIR PROPER SEQUENCE, YOU CANNOT EXPECT ACCURATE CUTTING RESULTS.

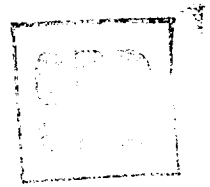

In addition to the proper alignment of your saw, you must also become familiar with the following practices in order to expect the best results.

1. Edge of workpiece which is placed against fence must be as straight as the long side of your framing square.
2. Workpiece must be as flat as the front table board on your saw.
3. There must be no sawdust or other wood chips between the fence and front table board.
4. There must be no sawdust or other wood chips underneath workpiece or between workpiece and fence.
5. Workpiece must be held tightly against fence . . . this is especially important when making angle cuts because the workpiece has a tendency to move.
6. Always use the correct Sawblade for the Job . . . Always keep it sharp.
7. When making a four sided frame:
 - a. The two side pieces must be exactly the same length.
 - b. The top and bottom pieces must be exactly the same length.
 - c. Always place the same edge of the workpiece against, the fence . . . turn the workpiece end for end for the successive cuts and mark a pencil line on the table for gauging the required length.

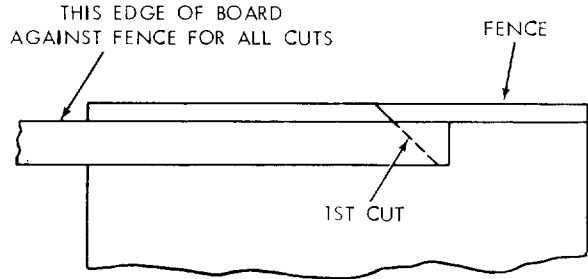

Turn workpiece over end for end . . . keep same edge against fence when making successive cuts.

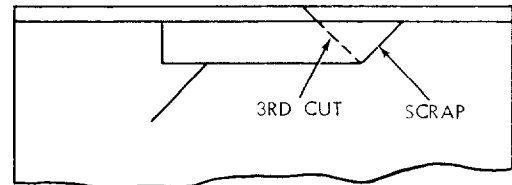
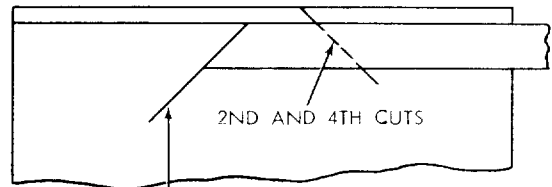

Deviations from any of the above practices will have an effect on the accuracy of the cuts that you make.

basic saw operations

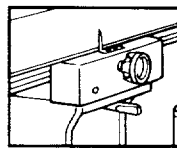

Basic saw operations are summarized into six categories, explained and illustrated in the following paragraphs. A book entitled "Power Tool Know How Radial Saw" is available at your nearest Sears Retail Store or Catalog Store. This book contains considerable data applicable to the radial saw.

NOTE: Refer to paragraphs under "OPERATION" for illustrations and descriptions of controls.

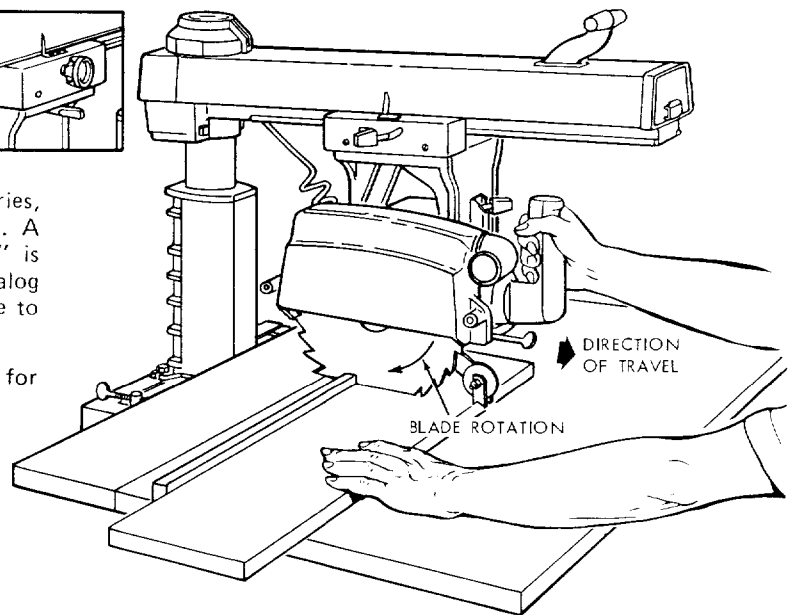

basic saw operations

REQUIREMENTS FOR CROSSCUT

Board position (stationary) against rip fence (guide) and laying flat on table top.

(OPERATIONS 1 THROUGH 4)

1. Arbor nut must be tight and saw blade guard installed in horizontal position.
2. Arm control lever must be in locked position.
3. Adjust the antikickback assembly so the pawls just clear the workpiece or the fence, whichever is higher.
4. Work must be held firmly against table and fence. For workpieces thicker than the fence is high, install a higher fence (at least workpiece thickness). Always place the fence in the most forward position (farthest from the column support) compatible with the workpiece being processed and the operation being performed. With the carriage fully retracted, the blade must not contact the workpiece when placed against the fence, within the stated capacities of your saw.
5. Blade should be sharp and correctly set.
6. Hands must be kept well away from saw blade.
7. Yoke clamp handle must be in locked position.
8. Bevel index lever must be locked.
9. Blade should cut into the table or plywood cover not more than 1/32 inch.
10. Pull the saw forward just far enough to sever the lumber. It is dangerous if the blade has been pulled too far out beyond the piece being cut. When it is returned it can pick up the right hand piece and throw it over the fence.
11. For operations No. 3 and No. 4, observe additional instructions under paragraph "Operating Controls" "Blade Angle".

OPERATION No. 1 – CROSSCUT

Crosscutting is the process of sawing the workpiece by pulling the saw blade through it and using the fence as a support for the edge of the workpiece. Never crosscut free-hand.

WARNING: BEFORE CROSSCUTTING, MAKE SURE THE ARM CONTROL LEVER, BEVEL LOCK LEVER AND YOKE CLAMP ARE ALL LOCKED. NEVER USE A LENGTH STOP OR A FIXED GUIDE ON THE FREE END OR EDGE OF A WORKPIECE. DO NOT CROSSCUT WORKPIECES THAT PLACE YOUR HANDS CLOSE TO THE PATH OF THE SAW BLADE. WHEN MORE EXPERIENCE IS GAINED BY USING THE SAW, IT WILL BE NOTICED, THAT WHEN PULLING THE SAW TOWARD YOU DURING CROSSCUTTING, THE BLADE TENDS TO FEED ITSELF THROUGH THE WORK DUE TO THE ROTATION OF THE BLADE AND THE DIRECTION OF THE FEED. THEREFORE, YOU SHOULD DEVELOP THE HABIT OF HOLDING YOUR RIGHT ARM STRAIGHT FROM THE SHOULDER TO THE WRIST.

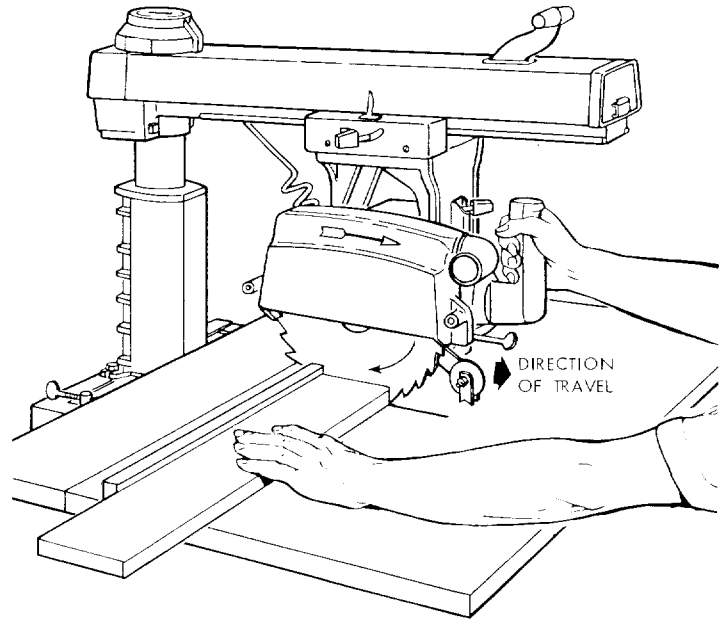

PROPER
(SEE ITEM "10" AT LEFT)

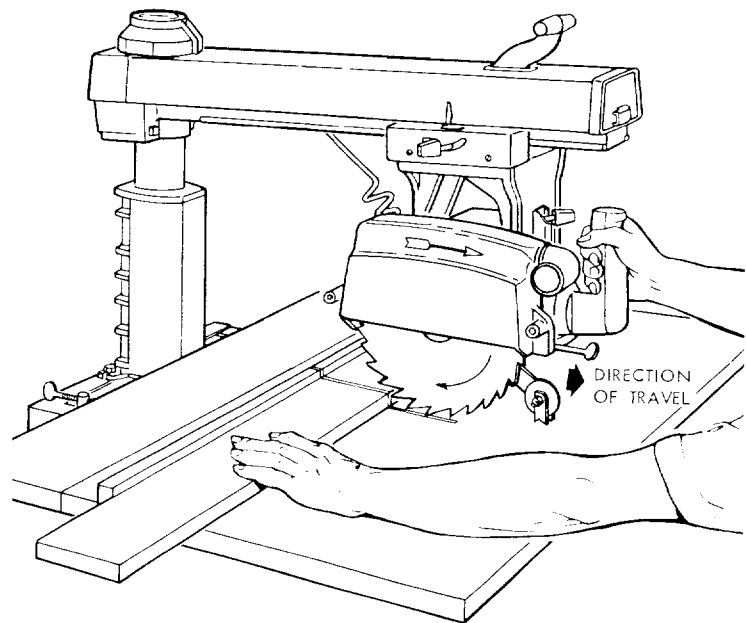

IMPROPER
(SEE ITEM "10" AT LEFT)

REPETITIVE CROSSCUTTING

Clamp a "C" clamp (min. 6 inch) using a wood block on each side of the arm. This will limit the carriage travel beyond the position necessary to complete the crosscut operation.

basic saw operations

OPERATION No. 2 – MITER CROSSCUT

Miter crosscutting is the process of sawing a board at any angle other than a 90° (square) cut. The 45° miter angle is a popular one, since two boards cut to 45° can be assembled to form a 90° corner for producing a square or rectangular frame. The radial arm is set to the desired angle of cut; yoke and bevel settings indexed at 0° (and locked) as in square crosscutting. The board being cut is held firmly against the fence (guide) and the carriage pulled forward along the radial arm to perform the desired cut. As in "Operation No. 1", the carriage should be returned to full rear position and the saw blade allowed to come to a complete stop before removing the boards from saw table.

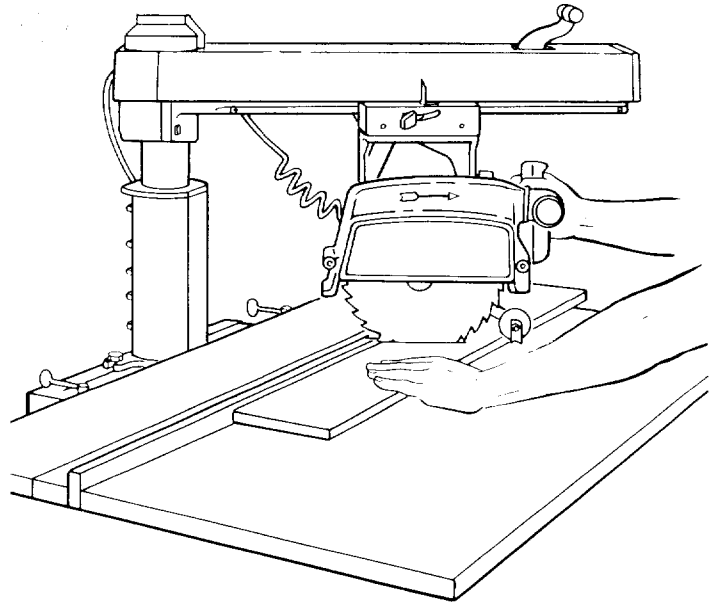

OPERATION No. 3 – BEVEL CROSSCUT

Bevel crosscutting is the process of sawing at 90° (square) across the board with the saw blade set at an angle other than 90° to the saw table. The radial arm and yoke are indexed at 0° and locked, but the bevel is set to the desired angle of cut. The board is held firmly against the fence and the carriage pulled forward along the radial arm to produce the cut. The carriage should be returned to full rearward position and the saw blade allowed to come to a complete stop before removing the boards from saw table.

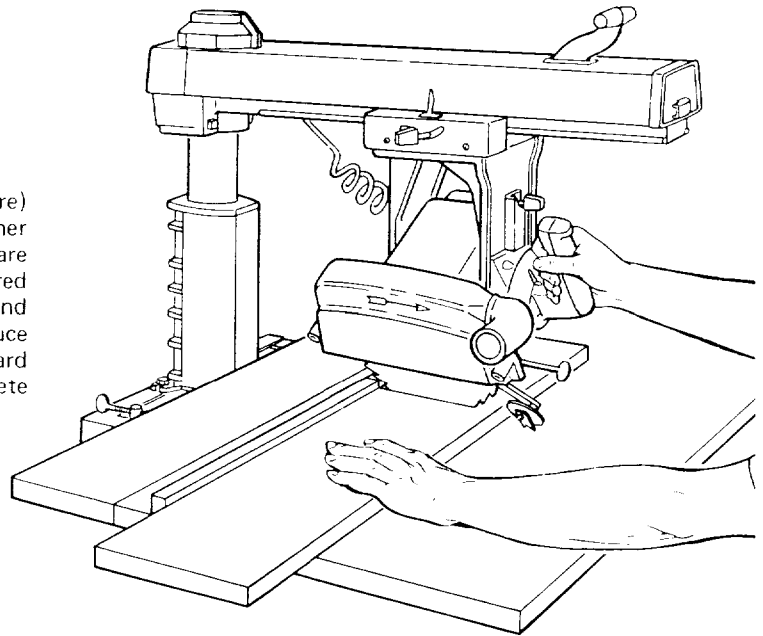

OPERATION No. 4 – COMPOUND CROSSCUT

Compound crosscutting is the combination of miter and bevel crosscuts. The radial arm and bevel are set to produce the desired cut; the yoke is indexed at 0° and locked. The board is held firmly against the fence and the carriage pulled forward along the radial arm to produce the cut. Again, the carriage should be returned to full rearward position and the saw blade allowed to come to a complete stop before removing boards from saw table.

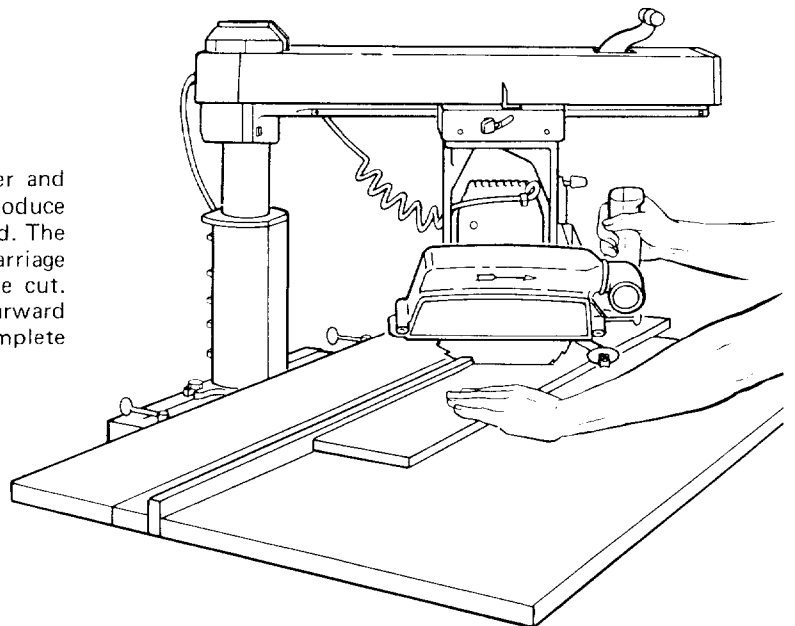

REQUIREMENTS WHEN RIPPING (OPERATIONS 5 AND 6)

1. Carriage lock knob must be locked.
2. Radial arm must be locked in 0° position.
3. Work must be held firmly against table and fence while feeding through.
4. **Guard spreader and antikickback mechanism must be properly set. OBSERVE INSTRUCTIONS IN PARAGRAPH, "POSITIONING GUARD, AND ANTIKICKBACK AND SPREADER ASSEMBLY FOR RIPPING" UNDER "LOCATION AND FUNCTION OF CONTROLS".**
5. Blade should be sharp and correctly set.
6. When ripping narrow stock, less than 3 inches but more than 1/4 inch between the guard and the fence (guide), use a "Push Stick" at least 1/4" thick and at least 16" long so the workpiece is clear of the blade before your hand contacts the guard.

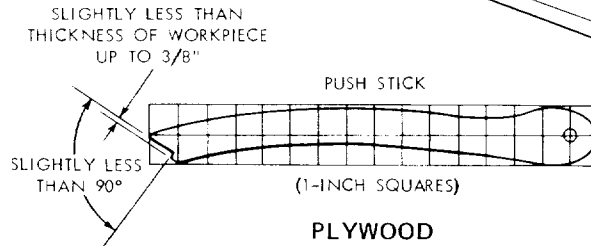
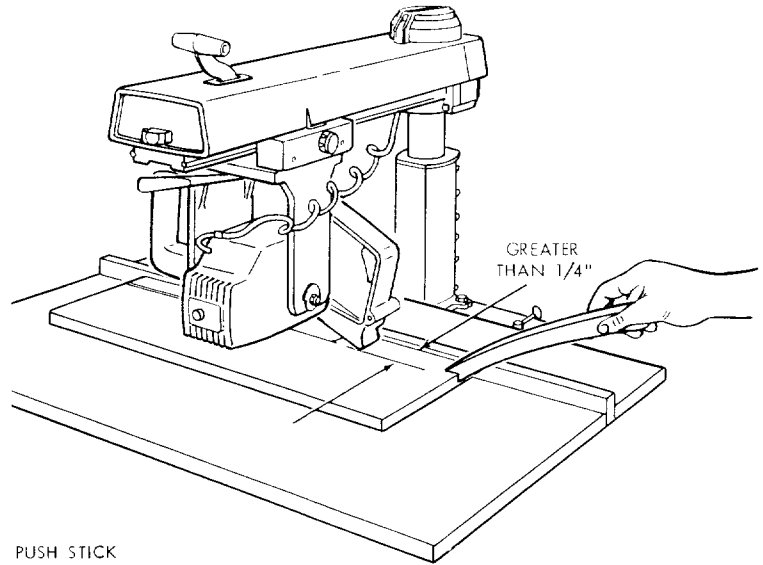

7. When ripping stock 1/4 inch or less between the blade and fence (guide) use a Pusher Board.

Pusher board should not be less than 3 inches wide and 16 inches long. Nail or glue a 3/4 x 3/4 x 4 inch block to one edge of pusher board to be used as a grip.

The pusher board should be fed into the blade behind the stock being ripped until the stock is clear of the rear of the blade (not more than 8 inches so as not to strike antikickback pawls) and then pulled back with use of the grip.

8. Hands must be kept well away from saw blade.
9. Saw blade **MUST** be parallel to fence, to minimize possibility of kickbacks.
10. For every new width of cut, a new **PUSHER BOARD** – or a reworked **PUSHER BOARD** to remove the material containing the kerf – must be used.
11. The pusher board should be the same thickness as the workpiece. No thinner for strength, or no thicker since the nose of the guard must clear the top of the workpiece with minimum clearance.

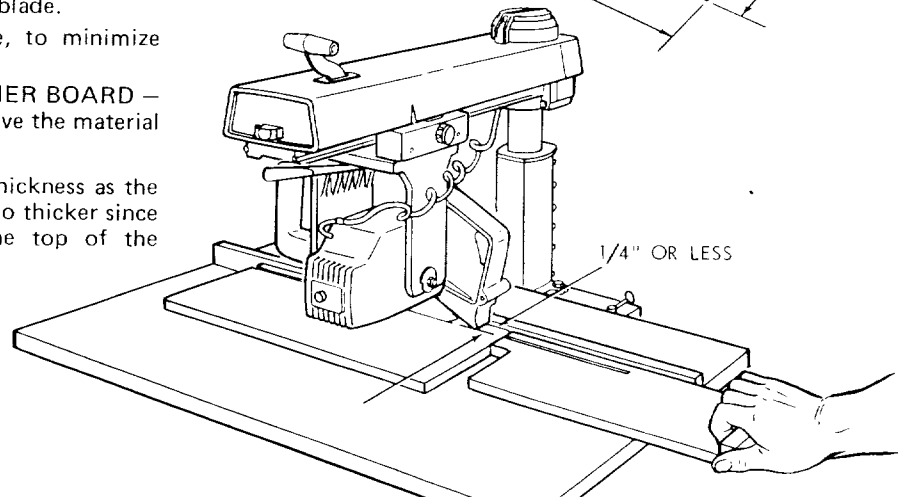
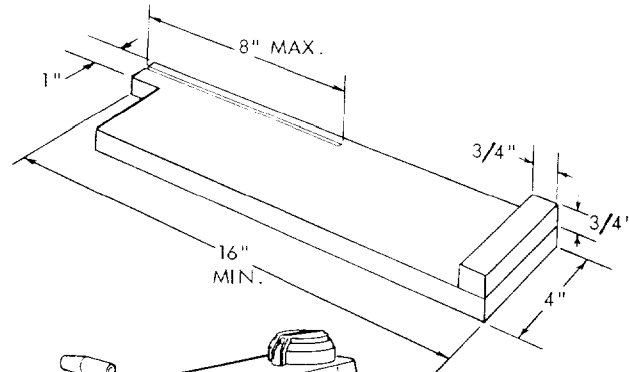

OPERATION No. 5 – OUT-RIPPING AND IN-RIPPING

1. Ripping is the process of sawing the workpiece by feeding it into the saw blade when using the fence as a guide and as a positioning device to obtain the desired width of cut. The sawblade is parallel to the fence.

WARNING: NEVER RIP FREE-HAND. BEFORE RIPPING, MAKE SURE THE GUARD, AND ANTIKICKBACK AND SPREADER ASSEMBLY ARE SET UP PROPERLY. ALSO, MAKE SURE THE SAW BLADE IS PARALLEL WITH THE FENCE. NEVER RIP WORKPIECES SHORTER THAN THE SAW BLADE DIAMETER.

2. Since the work is pushed along the fence, it must have a straight edge in order to make sliding contact with the fence. Also, the work must make solid contact with the table, so that it will not wobble. Provide a straight edge, even if this means temporarily nailing of an auxiliary straight-edged board to the work. If the workpiece is warped, turn the hollow side down.
3. Always use the saw guard and make sure the spreader is correctly aligned with the saw kerf and antikickback pawls properly adjusted. Wood cut with the grain tends to spring the kerf closed and bind the blade and a kickback could occur.
4. Stand a little to one side of center to be clear of work in case of kickback.
5. When ripping short or narrow work, always use a push stick applied to the section of the workpiece between the blade and fence . . . push the work past the blade so it is clear of the blade. This procedure will minimize the possibility of kickbacks.

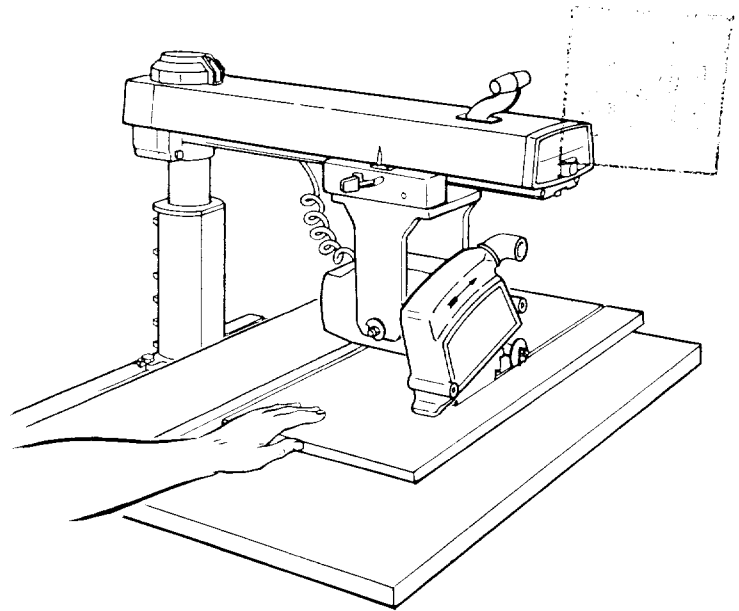

Out-Ripping. The radial arm and bevel are indexed at 0° and locked, but the yoke is turned 90-degrees in a counterclockwise direction (viewed from above), from the crosscut position. When standing in front of the saw, blade would be rotating clockwise. After positioning the guard and antikickback mechanism the workpiece is fed from the left-hand side of the saw. The "Blade Out-Rip" scale is on the left hand side of radial arm.

In-Ripping. The radial arm and bevel are indexed at 0° and locked, but the yoke is turned 90-degrees in a clockwise direction (viewed from above) from the crosscut position. Thus, when standing in front of the saw, the blade would be rotating counterclockwise. After positioning the guard and antikickback mechanism the workpiece is fed from the right-hand side of the saw. The "Blade In-Rip" scale is on the right-hand side of radial arm.

OPERATION No. 6 – BEVEL RIPPING

Bevel ripping is either in-ripping or out-ripping as described above, except the saw blade is tilted out of perpendicular to the saw table surface. The radial arm is indexed at 0° and locked, the bevel is set to the desired bevel angle and the yoke is positioned for in-ripping (saw blade at rear) or out-ripping (saw blade at front), as required. All requirements and observations applicable to normal ripping operations also apply to bevel ripping.

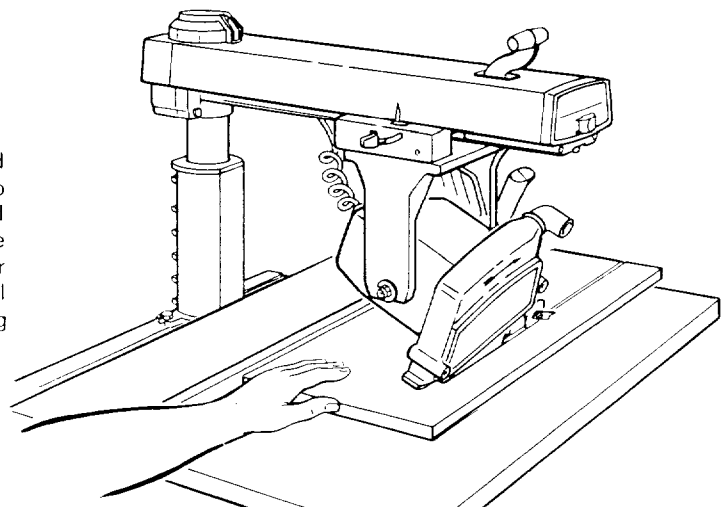

DADOING

Instructions for operating the Dado Head are contained in booklet furnished with the Dado Head.

The saw arbor is designed for dado heads up to 13/16 inches wide. Do not install a wider dado head on the arbor. Take several passes if required dado cut exceeds 13/16 inch.

When installing the dado head on the arbor, ALWAYS install the inside "loose collar" first. Be sure the teeth of the chippers are placed to fall in blade gullets, and chippers are approximately equally spaced around the arbor.

DO NOT install the outside loose collar. Make sure the arbor nut is tight. Install the arbor nut directly against the outer blade of dado head.

For best results and to avoid excessive load on the motor, NEVER CUT A 13/16" WIDE DADO, DEEPER THAN 3/4" IN ONE PASS.

NEVER USE A DADO HEAD OR MOLDING HEAD WITH THE SAW ARBOR VERTICAL WITHOUT INSTALLING AND ADJUSTING A MOLDING HEAD/DADO GUARD.

MOLDING/SANDING

Instructions for operating the Molding Head are contained in a booklet furnished with the Molding Head.

For use of Molding Head Cutter or Drum Sander the rear table requires an opening (next to rear face of fence) for clearance. Cut this opening as shown.

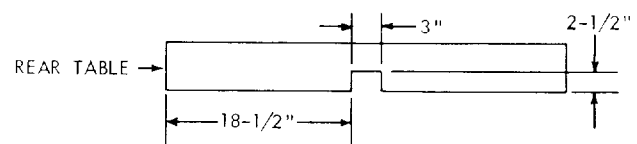

adjustments to compensate for wear

ADJUSTING BEVEL LOCK LEVER

1. The purpose of this lever is to lock the motor at any angle. To adjust, remove the set screw with wrench as shown. Use the bevel lock lever as a wrench to tighten the clamp bolt. Do Not Over Tighten. Replace bevel lock lever in locked position and tighten the set screw.

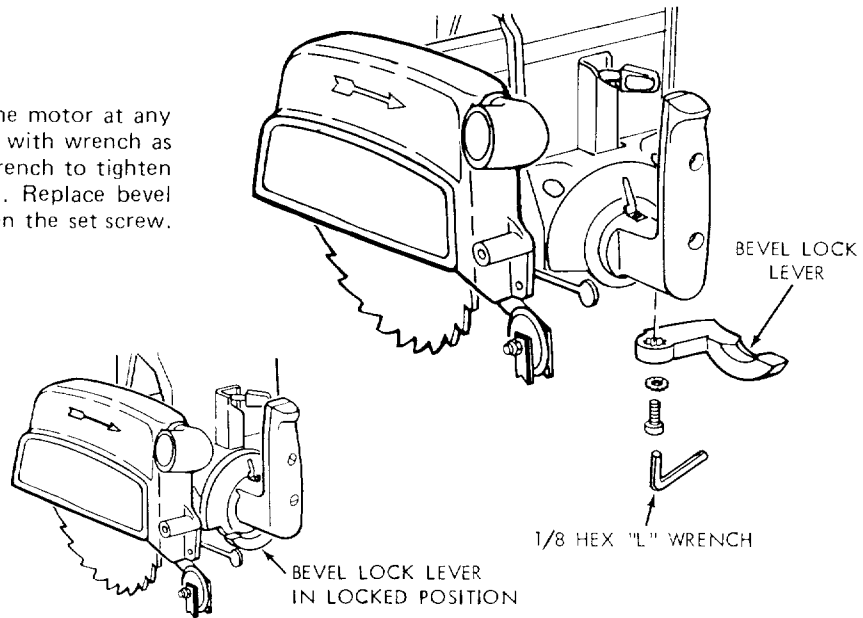

YOKE LOCK HANDLE ADJUSTMENT.

1. This handle provides a friction lock between the upper face of the yoke and the bottom face of the carriage. It should eliminate any play or rotation between these two parts when locked. Its proper position for saw operation is approximately midway between the two sides of the yoke.
When sufficient wear has occurred to permit the handle to move considerably to the rear, or strike the yoke before locking, the handle must be adjusted as follows:
2. Remove carriage stop screw and lockwasher with a 1/4 inch hex-L wrench.
3. Grasp the carriage assembly, move it carefully off the end of radial arm, holding it parallel to the radial arm until all carriage bearings are free of their tracks.
4. Rest the motor and carriage assembly on saw work table and re-install carriage stop screw and lockwasher.

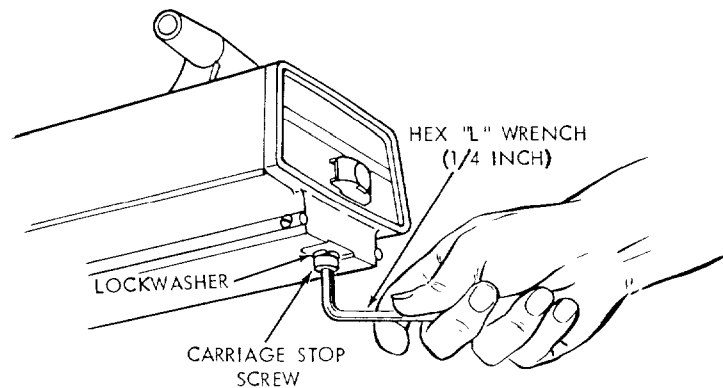

To Readjust

5. Set yoke lock handle at unlocked position. Tighten nut with 15/16 wrench, until lock handle locks mid-way between the two sides of the yoke. Remove carriage stop screw and lockwasher.
6. Hold the motor and carriage assembly parallel to radial arm and start the rear bearings onto the tracks. Continue to hold the assembly parallel to the tracks until the forward bearings are on the tracks.
7. Slide the carriage rearward on the radial arm and **INSTALL THE CARRIAGE STOP SCREW AND LOCKWASHER.**

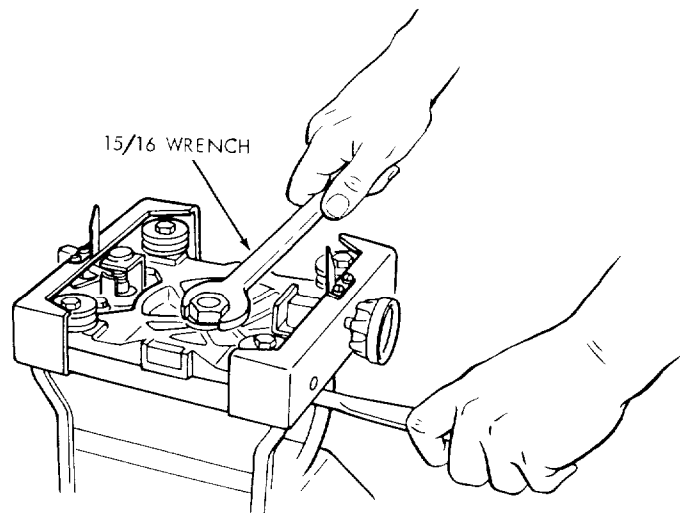

adjustments to compensate for wear

ARM TO COLUMN

1. With the arm control lever unlocked and in index release position, the arm should move firmly with no vertical play in the arm.
The arm should fit snugly on the column. If not, then adjust.
 - a. Remove two (2) screws from rear cover plate and tighten evenly top two 3/8-16 bolts, until arm moves firmly and there is no vertical or horizontal movement in the arm when arm control lever is locked or unlocked.
 - b. Bottom two nuts should be snugged evenly, but not nearly as tight as top two bolts.
 - c. Re-Install Rear Cover Plate.

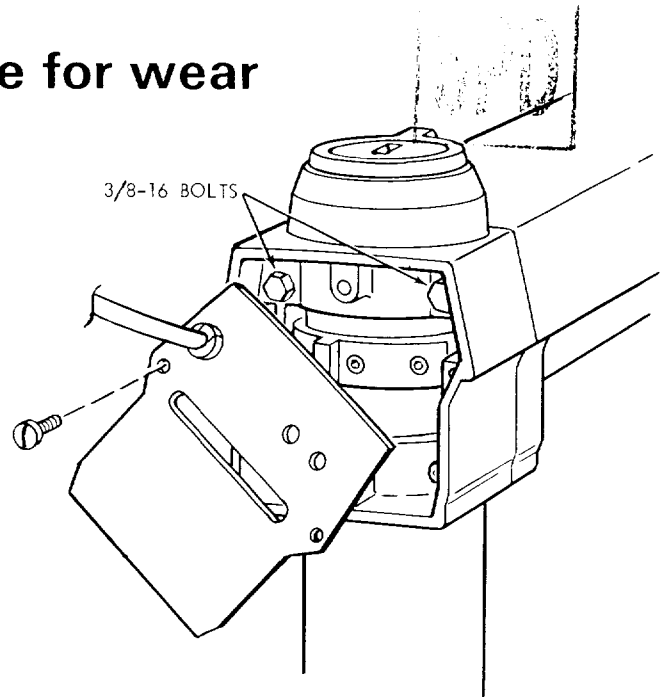

ADJUSTING CARRIAGE BEARINGS

In proper adjustment the top and bottom radii of all four bearings should be in contact with the arm tracks for their entire length and carriage should roll freely but with some resistance.

To test for looseness between bearings and tracks on radial arm, perform the following steps.

1. Remove left-hand carriage cover.
2. Push the carriage to its full most rearward position.
3. Finger hold front carriage bearing as shown and apply as much force as possible and at the same time pull carriage forward. If you can stop the bearing from turning it will require adjusting.
4. Check rear bearing in the same manner and adjust as follows:
 - a. Loosen nuts just enough to permit the eccentric screws to turn.
 - b. Rotate the eccentric screws a partial turn (left or right) as required to take up looseness.
 - c. Hold the heads of eccentric screws in the position established in the preceding step and tighten nuts on underside of carriage. Correct adjustment exists when you cannot keep the bearings from turning. However, excessive bearing pressure will cause difficult operation and rapid wear.
 - d. Install carriage cover.

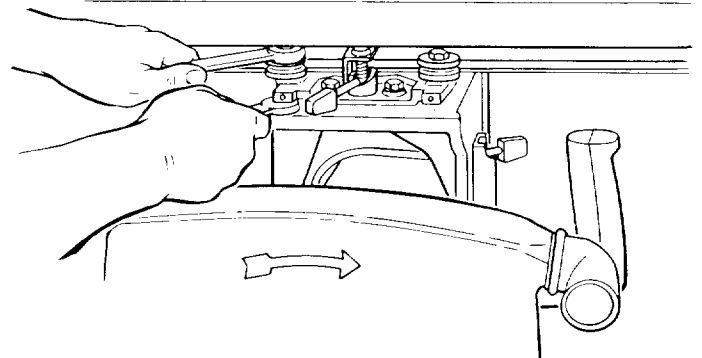
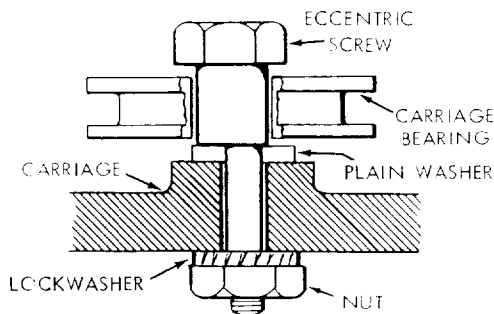
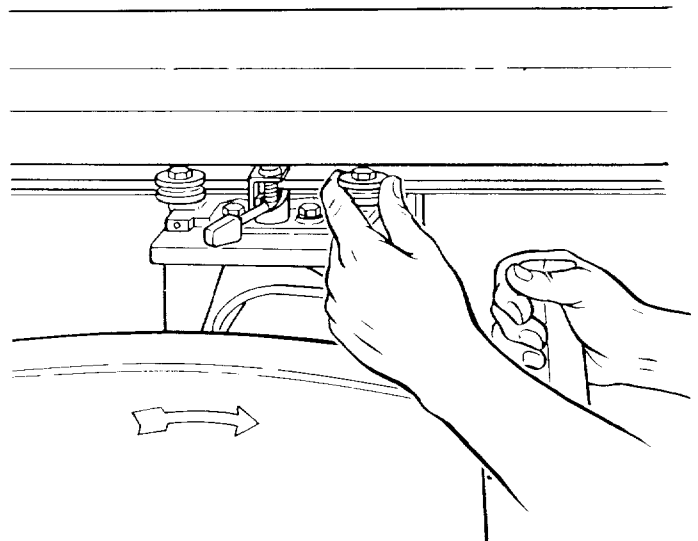

ARM LOCK ADJUSTING WHEEL

Arm control lever operates a brake shoe that locks and releases the arm, and automatically releases the arm index pin for 0° & 45° miter settings.

The lock action should feel tight and secure. Considerable amount of effort must be applied to the lever to lock the arm.

NOTE: Lever must be in unlocked position while making adjustment.

If adjustment is required, turn arm lock adjusting wheel under front of the arm clockwise to tighten, counter-clockwise to loosen.

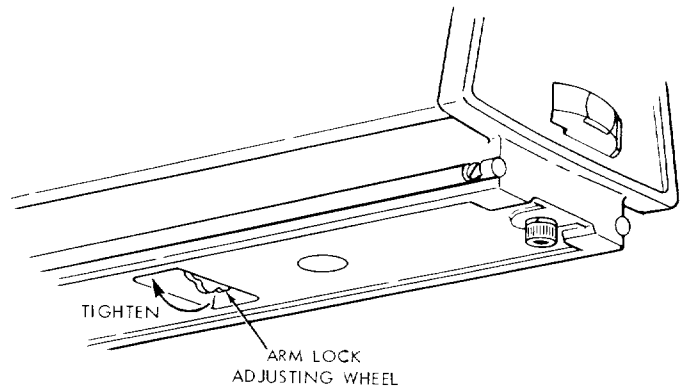

ARM INDEX ROD ADJUSTMENT

At some time it may be necessary to make an adjustment to the Arm Index Rod, to compensate for wear in the Indexing System.

An indication that this adjustment must be made is when one of the following occurs:

IMPORTANT: ARM LOCK/ADJUSTING WHEEL (SEE ABOVE) MUST BE PROPERLY ADJUSTED AT THIS TIME.

1. With the arm control lever pulled forward and held in the "Index Release" position, the arm cannot be moved out of the Indexed position. (Index pin not fully retracting from Index ring).
2. With the arm in one of the Index positions and the arm control lever allowed to rest in the **Unlocked** position (with the column tube supports and gibs adjusted properly eliminating all play in this area). A slight side to side movement is noticeable at the front of the arm. (Index pin not fully seated in Index Ring).

To make an adjustment to the arm Index rod the following steps must be taken.

1. Removing Arm Trim (Shroud)

- a. Remove miter indicator. Snap fit.
- b. Remove miter scale by removing two #10 Pan Head screws.
- c. Remove knobs from arm control lever.
- d. Remove stop screw and lockwasher in arm. Remove carriage. **RE-INSTALL STOP SCREW AND LOCKWASHER.**
- e. Grasp arm trim and remove.
- f. Remove arm trim pad.

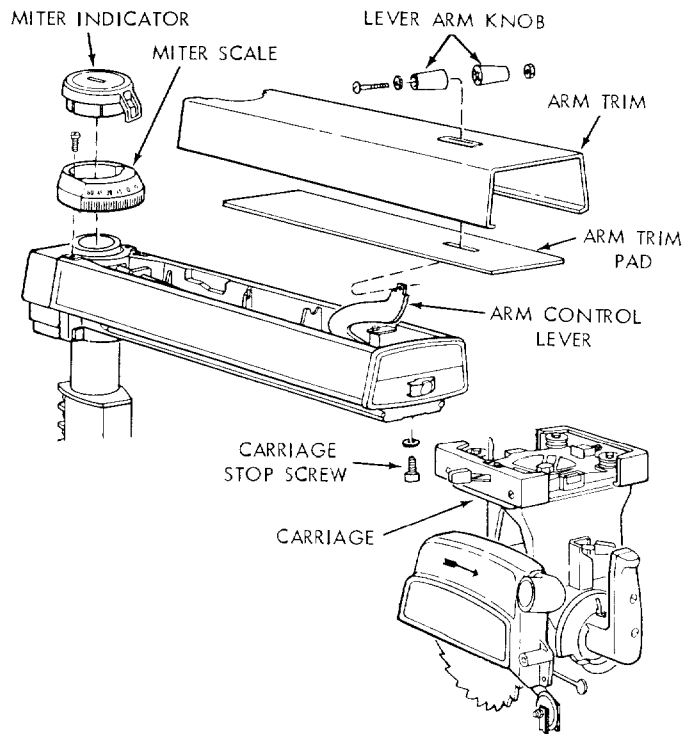

2. Adjusting Index Rod.

- a. Loosen carriage bolt and nut which holds adjusting bracket in place.
- b. Position arm in 0° Index.
- c. Bring adjusting bracket forward until it is approximately 1/16 inch from contacting Index rod. Or until it is in the extreme forward position on the mounting slot.
- d. Tighten carriage bolt & nut. Test indexing action in all Index positions.

3. Reinstall parts that have been removed.

- a. Install arm trim pad.
- b. Remove Carriage Stop Screw and Lockwasher and install carriage. **REINSTALL CARRIAGE STOP SCREW, AND LOCKWASHER.**
- c. Install lever arm knob.
- d. Install miter scale and miter indicator. Set miter indicator to 0°.

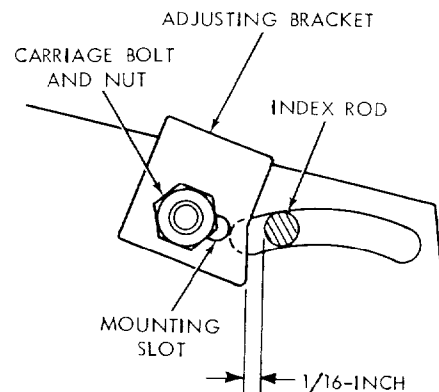

trouble-shooting



WARNING: REMOVE POWER CORD FROM POWER SOURCE BEFORE TROUBLE SHOOTING.

NOTE: Changing one adjustment will effect another, so it is best to perform all of the alignment procedures when correcting any one problem.

The usual operating "troubles" are listed in the following paragraphs with the necessary corrections listed.

1. RADIAL SAW DOES NOT MAKE ACCURATE 0° or 45° MITER CROSSCUTS.

- a. **Looseness between column tube and column support.**
Align as described in Alignment Procedure Section Step Two.
- b. **Crosscut travel not properly adjusted.**
Refer to Step Three in Alignment Procedure Section Squaring Crosscut Travel.
- c. **Column is Loose in Support.**
Refer to Step Two in Alignment Procedure.
- d. **Arm Not Indexing Properly.**
Refer to Arm Index Rod Adjustment in Adjustments to Compensate for Wear section.
- e. **Carriage Assembly Loose on Arm.**
Refer to Carriage Bearing Adjustment in adjustment to Compensate for Wear Sections.
- f. **Looseness between Yoke and Carriage Assembly.**
Refer to "Yoke Lock Handle" adjustment in adjustment to Compensate for Wear Section.

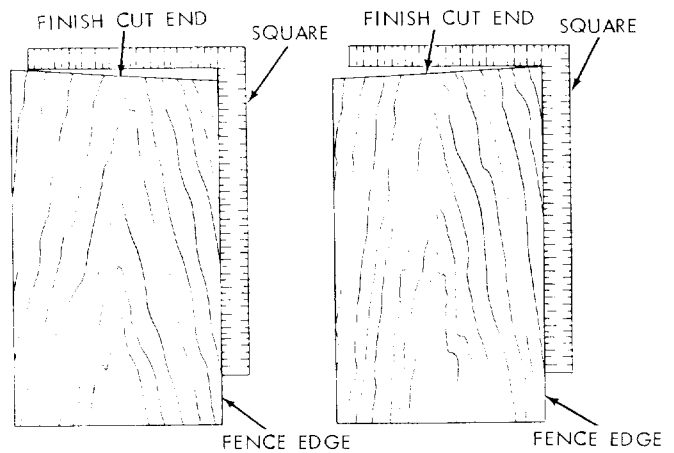

FINISH CUT LOOKS LIKE THIS – 0° CROSSCUT

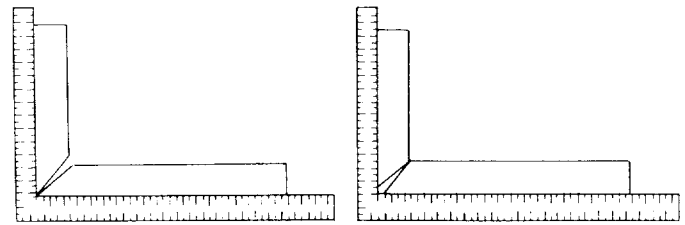

OR LIKE THIS – 45° MITER.

- g. **Sawdust between Work Piece and Fence.**
Keep Front Work Table Clean.
- h. **Rip Fence Not Straight.**
Replace Fence.

2. SAW CUTS AT ANGLE – NOT 90° TO TABLE TOP.

- a. **Table support channels not properly leveled.**
Refer to Step One under Alignment Procedure Section.
- b. **Blade not square to work table top.**
Refer to Step Four in Alignment Procedure Section.

3. BLADE ANGLE (BEVEL) CUTS NOT ACCURATE.

- a. **Corrective Action is the same as paragraph 2A and B above.**
- b. **Carriage Bearings Loose.**
Refer to adjusting carriage bearing in adjustments to compensate for wear section.

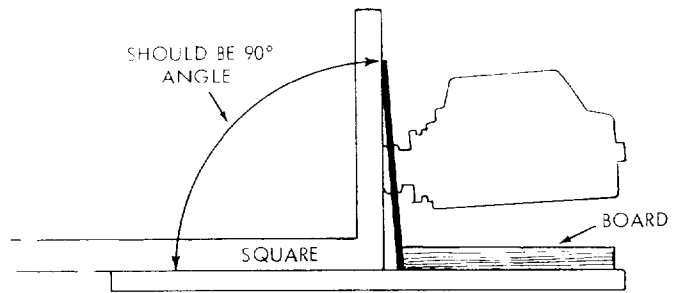

- c. **Bevel Lock Handle Loose.**
Refer to Adjustment Bevel Lock Handle in Adjustment to Compensate for Wear Section.

4. SAW KERF (CUT EDGE) OF STOCK ROUGH – TOOTH MARKS LEFT ON EDGE OF SAW KERF.

NOTE: This condition is commonly called "HEEL".

- a. **Crosscutting or Miter Cutting**
"Heeling" will tend to slide the workpiece along the guide fence, as the cut is being made, and make a square cut almost impossible.
Refer to step 5 under Alignment Procedure Section – "Squaring Blade to Fence."
- b. **Bevel Crosscutting Or Bevel Ripping.**
Refer to Step 5 Under Alignment Procedure Section Vertical Heel Adjusting.
- c. **Using Improper Blade for Finish Cut Desired.**
Use Proper Smooth Cutting Blade.

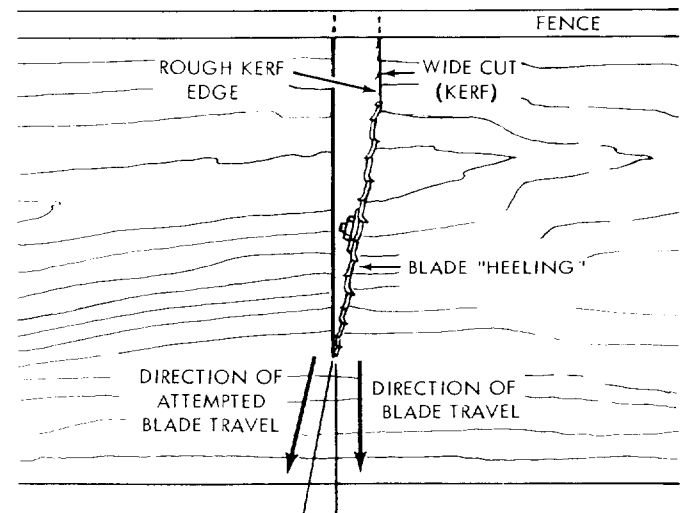

trouble-shooting

5. WOOD BINDS, SMOKES AND MOTOR SLOWS DOWN OR STOPS WHEN RIPPING.

a. Dull blade or warped board.

Sharpen or replace the saw blade. Avoid the attempted use of severely warped material.

b. Feed rate too fast.

Slow Feed Rate.

c. Saw blade heels.

Check and align as described in Alignment Procedure Section, Step Five.

d. Fence not straight.

Replace fence.

e. Carriage Assembly Loose on Arm.

Refer to adjusting carriage bearings in adjustments to compensate for wear section.

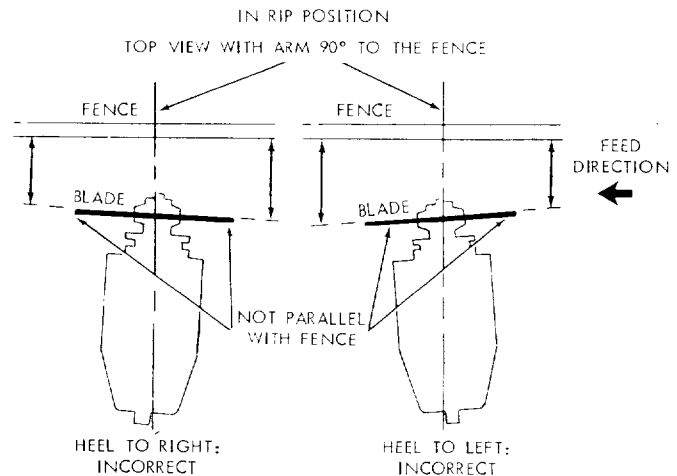

6. BOARD PULLS AWAY FROM FENCE WHEN RIPPING.

a. Saw Blade has heel.

Corrective action is the same as preceding instructions explained in paragraph c.

7. WORKPIECE STRIKES SPREADER WHEN RIPPING.

a. Adjust spreader per instructions in Step Six under "Alignment of Spreader for Ripping".

8. SAW DOES NOT TRAVEL SMOOTHLY ON ARM TRACKS.

a. Dirty tracks.

Clean Tracks.

b. Bad Bearing.

Replace Bearing.

c. Worn Tracks

Replace Tracks

9. CLAMPING FORCE NOT SUFFICIENT AT MITER ANGLES OTHER THAN 45°.

a. Arm Control Lever requires Adjustment.

Refer to Arm Lock Adjusting Wheel in Adjustments to Compensate for Wear Section.

10. CLAMPING FORCE NOT SUFFICIENT AT BEVEL ANGLES OTHER THAN 45°.

a. Bevel Lock Lever Requires adjusting.

Refer to Adjusting Bevel Lock Lever in Adjustments to Compensate for Wear Section.

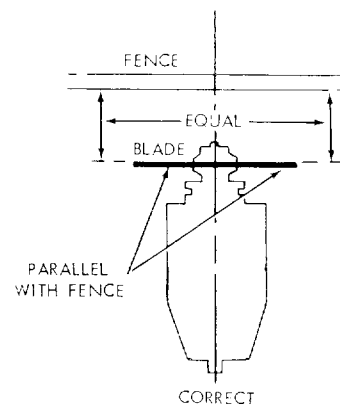

11. DEPTH OF CUT VARIES FROM ONE END OF WORK PIECE TO THE OTHER.

a. Table Top not parallel with Arm.

Refer to Attaching and Leveling table Mtg. Support Channels in Step One Align. Section.

12. BLADE TENDS TO ADVANCE THRU LUMBER TOO FAST.

a. Dull Blade.

Replace or sharpen blade.

b. Not advancing Saw Blade properly.

Draw Saw Blade across lumber with a slow and steady pull.

MOTOR TROUBLE - SHOOTING CHART

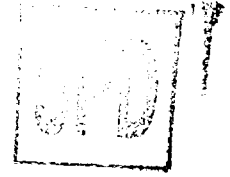

NOTE: Motors used on wood-working tools are particularly susceptible to the accumulation of sawdust and wood chips and should be blown out or "vacuumed" frequently to prevent interference with normal motor ventilation.

TROUBLE	PROBABLE CAUSE	SUGGESTED REMEDY
Motor will not run.	<ol style="list-style-type: none"> 1. Protector open; circuit broken. 2. Low voltage. 	<ol style="list-style-type: none"> 1. Reset protector by pushing on red button, located on top of motor (indicated by audible click). 2. Check power line for proper voltage.
Motor will not run and fuses "BLOW".	<ol style="list-style-type: none"> 1. Short circuit in line, cord or plug. 2. Short circuit in motor or loose connections. 3. Incorrect fuses in power line. 	<ol style="list-style-type: none"> 1. Inspect line, cord and plug for damaged insulation and shorted wires. 2. Inspect all terminals in motor for loose or shorted terminals or worn insulation on wires. 3. Install correct fuses.
Motor fails to develop full power. (Power output of motor decreases rapidly with decrease in voltage at motor terminals. For example: a reduction of 10% in voltage causes a reduction of 19% in maximum power output of which the motor is capable, while a reduction of 20% in voltage causes a reduction of 36% in maximum power output.)	<ol style="list-style-type: none"> 1. Power line overloaded with lights, appliances and other motors. 2. Undersize wires or circuit too long. 3. General overloading of power company's facilities. (In many sections of the country, demand for electrical power exceeds the capacity of existing generating and distribution systems.) 	<ol style="list-style-type: none"> 1. Reduce the line load. 2. Increase wire sizes, or reduce length of wiring. 3. Request a voltage check from the power company.
Motor overheats.	<ol style="list-style-type: none"> 1. Excessive feed rate when crosscutting or ripping. 2. Improper cooling. (Air circulation restricted through motor due to sawdust, etc.) 3. Saw blade has "heel". 	<ol style="list-style-type: none"> 1. Slow down rate of feed. 2. Clean out sawdust to provide normal air circulation through motor. 3. Refer to Alignment Procedure Section of manual Step Five.
Motor starts slowly or fails to come up to full speed.	<ol style="list-style-type: none"> 1. Low Voltage – will not trip starting switch. 	<ol style="list-style-type: none"> 1. Correct low voltage condition.
Motor stalls (resulting in blown fuses or tripped circuit breakers).	<ol style="list-style-type: none"> 1. Voltage too low to permit motor to reach operating speed. 2. Fuses or circuit breakers do not have sufficient capacity. 	<ol style="list-style-type: none"> 1. Correct the low line voltage condition. 2. Replace fuses or circuit breakers with proper capacity units.
Frequent opening of fuses or circuit breakers.	<ol style="list-style-type: none"> 1. Motor overloaded. 2. Fuses or circuit breakers do not have sufficient capacity. 	<ol style="list-style-type: none"> 1. Reduce motor load. 2. Replace fuses or circuit breakers.

maintenance and lubrication

MAINTENANCE

WARNING: FOR YOUR OWN SAFETY, TURN SWITCH "OFF" AND REMOVE PLUG FROM POWER SOURCE OUTLET BEFORE MAINTAINING OR LUBRICATING YOUR SAW.

When you receive your new Craftsman radial saw, it requires no lubrication. The radial saw has been partially aligned and all bearings are lubricated and sealed for life. In time, however, in order to keep your saw in perfect working order and accurate, it will be necessary to lubricate and realign. In fact, your radial saw needs more of a cleaning than a lubrication.

Make sure the teeth of the ANTIKICKBACK pawls are always sharp. Replace if not sharp.

LUBRICATION

Your saw is precision built and should be kept clean and properly lubricated. Before describing the various points which may periodically require lubrication, IT IS MORE IMPORTANT TO FIRST MENTION THE VARIOUS POINTS WHICH SHOULD NOT BE LUBRICATED.

NO LUBRICATION REQUIRED

Do not lubricate carriage ball bearings or motor bearings as these are sealed ball bearings and require no added lubrication.

Do not lubricate between radial arm cap and radial arm.

PERIODICALLY LUBRICATE THESE POINTS

Use SAE No. 10W-30 automotive engine oil and refer to Parts List for locations. Apply a few drops of oil along the swivel latch pin and bevel index pin only if the pin has a tendency to stick. Remove the left-hand carriage cover and use oil sparingly to prevent it from getting on the ball bearings or races.

A light film of oil should be wiped on the face of the column tube to lubricate the fit between the column tube, and column support.

The thread on the elevation shaft assembly can be lubricated through the oil hole in the center of the radial arm cap.

CAUTION: Excessive oil at any location will attract airborne dust particles and sawdust.

recommended accessories

ITEM	CAT.NO.
Stand	9-22205
Steel Legs	9-22238
Casters	9-22209
Key Chuck	9-2980
*Molding Head Guard — 7-inch	9-29524
*Molding Head Guard — 8-inch	9-29523
Rotary Surface Planer — Carbide Tip	9-29513
Sanding Wheel — 8-inch	9-2274
Sanding Wheel — 10-inch	9-22723
Dust Collector	9-16998
Dust Collector	9-29517
Taper Jig	9-3233
*Satin Cut Dado — 7-inch	9-3257
*Satin Cut Dado — 8-inch	9-3253
*Molding Head Single Cutter	9-3215
*Molding Head Three Cutter	9-3221
Sanding Drum — 3-inch	9-25246
• Lower Retractable Guard	9-29009
“Power Tool Know How Handbook” Radial Saw	9-2917

*Before purchasing or using any of these accessories, read and comply with additional safety instructions No. “(D)2” on p. 4 of this manual.

•Meets OSHA Requirements as of 8-73.

The above recommended accessories are current and were available at the time this manual was printed.

repair parts

PARTS LIST FOR CRAFTSMAN 10-INCH RADIAL SAW MODEL 113.197750

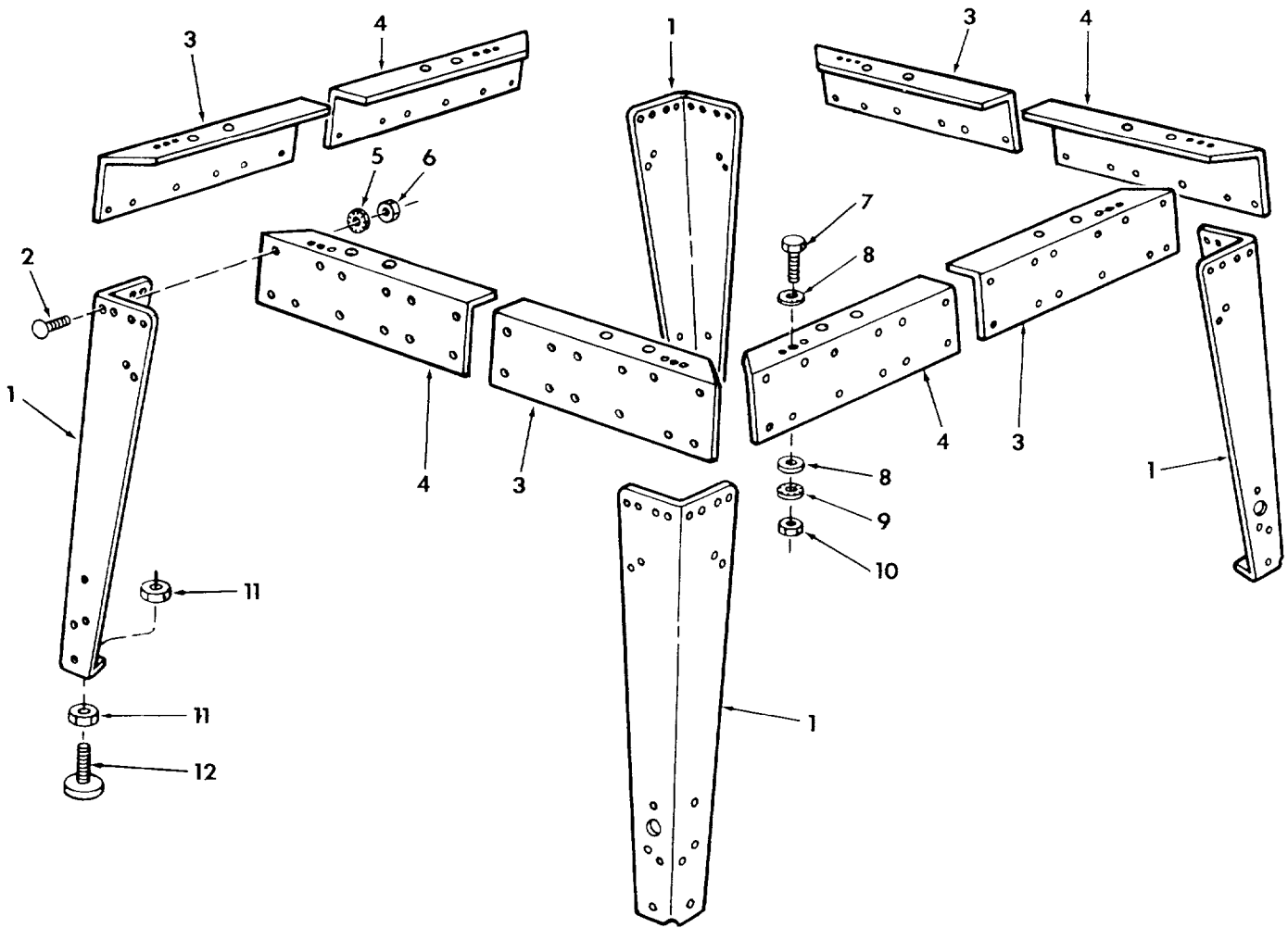
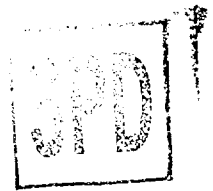

FIGURE 1 – LEG SET

Key No.	Part No.	Description
1	63749	Leg
2	60314	Screw, Truss Hd. 1/4-20 x 5/8
3	63751	Stiffener, R.H.
4	63750	Stiffener, L.H.
5	STD 551225	*Lockwasher, External 1/4
6	STD 541025	*Nut, Hex 1/4-20
7	STD 523106	*Screw, Hex Hd. 5/16-18 x 5/8
8	STD 551031	*Washer, 11/32 x 11/16 x 1/16
9	STD 551131	*Lockwasher, External 5/16
10	STD 541231	*Nut, Hex Jam 5/16-18
11	STD 541250	*Nut, Hex Jam 1/2-13
12	803835	Foot, Leveling
-	63752	Bag of Loose Parts (Not Illustrated)

* Standard Hardware Item – May be Purchased Locally.

PARTS LIST FOR CRAFTSMAN 10-INCH RADIAL SAW
MODEL NUMBER 113.19770 AND 113.197750

repair parts

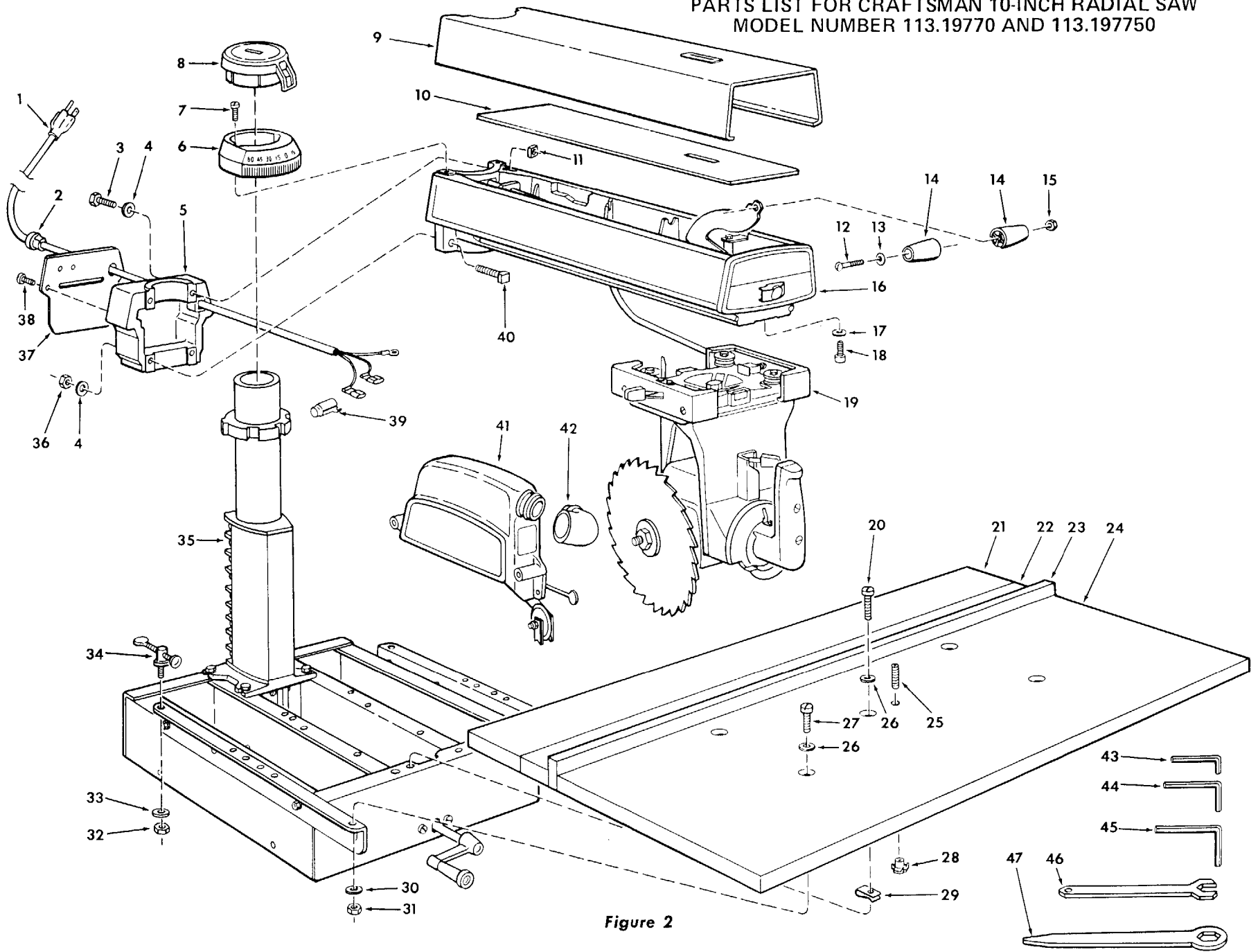

Figure 2

36

**PARTS LIST FOR CRAFTSMAN 10-INCH RADIAL SAW
MODEL NUMBER 113.19770 AND 113.197750**

Always order by Part Number — Not by Key Number.

FIGURE 2

Key No.	Part No.	Description
1	63518	Cord, with Plug
2	37818	Relief, Strain
3	60339	Screw, Hex Hd. Locking, 3/8-16 x 2-1/4 High Strength
4	60353	Washer, .380 x 47/64 x 1/8
5	63625	Arm, Rear
6	63669	Scale, Miter
7	STD 601103	*Screw, Type T Pan Hd. 10-32 x 3/8
8	63670	Indicator, Miter
9	63668	Trim Assembly
10	63686	Pad, Arm Trim
11	STD 541037	Nut, Square 3/8-16
12	436594	*Screw, Pan Hd. 10-32 x 1-1/2
13	STD 551010	*Washer, 13/64 x 7/16 x 1/16
14	63671	Knob, Lever Arm
15	STD 541110	*Nut, Hex 10/32
16	—	Arm Assembly, See Fig. 5
17	STD 551131	*Lockwasher, 5/16
18	9421620	Screw, Soc. Hd. Cap 5/16-18 x 1/2
19	—	Yoke Assembly, See Fig. 3
20	STD 512520	*Screw, Pan Hd. 1/4-20 x 1-3/4
21	63675	Table, Rear
22	63429	Table, Spacer
23	63432	Fence, Rip
24	63674	Table, Front
25	102711	Screw, Set Sl. Cup 1/4-20 x 1

Key No.	Part No.	Description
26	STD 551025	*Washer, 17/64 x 5/8 x 1/32
27	STD 512510	*Screw, Pan Hd. 1/4-20 x 1
28	37384	Nut, Tee
29	37530	Nut, "U" Clip
30	STD 551125	*Lockwasher, 1/4
31	STD 541025	*Nut, Hex 1/4-20
32	STD 541431	*Nut, Lock 5/16-18
33	STD 551031	*Washer, 21/64 x 9/16 x 1/16
34	63536	Clamp, Table
35	—	Base Assembly, See Fig. 4
36	STD 541437	*Nut, Lock 3/8-16
37	63666	Plate, Rear Cover
38	STD 601103	*Screw, Type T Pan Hd. 10-32 x 3/8
39	63467	Cap, Flag Terminal
40	60342	Bolt, Sq. Hd. 3/8-16 x 2-1/4 High Strength
41	—	Guard Assembly, See Fig. 6
42	63258	Elbow, Dust
43	30505	*Wrench, Hex "L" 1/8
44	63683	Wrench, Hex "L" 3/16
45	63682	Wrench, Hex "L" 1/4
46	63062	Wrench, Shaft
47	3540	Wrench, Arbor
—	63677	Bag, Loose Parts (Not Illustrated)
—	63678	Bag, Loose Parts (Not Illustrated)
—	63676	Owners Manual (Not Illustrated)

*Standard Hardware Item — May be Purchased Locally.

**PARTS LIST FOR CRAFTSMAN 10-INCH RADIAL SAW
MODEL NUMBER 113.19770 AND 113.197750**

FIGURE 3 – YOKE ASSEMBLY

Key No.	Part No.	Description
1	STD 601105	*Screw, Type "T" Pan Hd. 10-32 x 1/2
2	63661	Cover, L. H. Carriage
3	63679	Indicator, Rip
4	STD 510605	*Screw, Pan Hd. 6-32 x 1/2
5	120399	Nut, Square 5/16-18
6	63657	Housing, Index Pin
7	63655	Pin Assembly, Index
8	63658	Spring, Index
9	63656	Bracket, Spring
10	STD 551031	*Washer, 21/64 x 3/4 x 1/16
11	114605	*Lockwasher, 5/16, Ext. Tooth
12	STD 523107	*Screw, Hex Hd. 5/16-18 x 3/4
13	37387	Screw, Eccentric
14	60336	Bolt, Hex Hd. 5/16-18 x 1-1/2 High Strength
15	63117	Bearing, Carriage
16	60040	Washer, 5/16 x 3/4 x .062
17	STD 541462	*Nut, Lock 5/8-11
18	STD 551062	*Washer, .630 x 1.125 x .093
19	30567	Bumper
20	37388	Bearing, Sleeve
21	63528	Shoe, Rip Lock
22	30521	Spring, Swivel Latch
23	63659	Cover, R. H. Carriage
24	63660	Knob Assembly
25	30530	Nut, Speed
26	63641	Carriage
27	STD 541231	*Nut, Hex Jam 5/16-18
28	30495	Nut, Shaft
29	30494	Collar
30	60175	†Blade, Saw
31	STD 541411	*Nut, Lock 3/8-16

Key No.	Part No.	Description
32	STD 551037	*Washer, .380 x 47/64 x 1/16
33	63652	Cam, Motor
34	63651	Stud, Motor
35	63469	Bushing, Rubber
36	63642	Yoke
37	63648	Knob Assembly, Bevel Index
38	63643	Stud, Yoke Clamp
39	63644	Handle, Yoke Lock
40	60333	Nut, Square L. H. 5/16-18
41	30521	Spring, Swivel Latch
42	63645	Pin, Index
43	63620	Scale, Bevel
44	60337	*Screw, Type "T" Pan Hd. 10-32 x 7/8
45	STD 600803	*Screw, Type "T" Pan Hd. 8/32 x 5/16
46	63662	Indicator, Bevel
47	63653	Handle, Yoke
48	63654	Trim, Handle
49	60338	*Screw, Type "T" Pan Hd. 10-32 x 1
50	9421628	Screw, Soc. Cap 5/16-18 x 2
51	9421627	Screw, Soc. Cap 5/16-18 x 1-5/8
52	STD 551131	*Lockwasher, 5/16
53	63650	Plate, Retainer
54	63649	Ring, Index
56	60335	Screw, Hex Hd. L. H. 5/16-18 x 2
57	63647	Level, Bevel Lock
58	STD 551210	*Lockwasher, Ext. Tooth No. 10
59	60334	Screw, Hex Soc. Button Hd. Cap 10-32 x 5/8
60	STD 523120	*Screw, Hex Hd. 5/16-18 x 2
61	63646	Cap, Yoke
62	63607	•Motor

*Standard Hardware Item – May be Purchased Locally.

†Stock Item – May be secured through the hardware departments of most Sears Retail Stores or Catalog Order Houses.

•Any attempt to repair this motor may create a HAZARD unless repair is done by a qualified service technician. Repair service is available at your nearest Sears Store.



PARTS LIST FOR CRAFTSMAN 10-INCH RADIAL SAW
MODEL NUMBER 113.19770 AND 113.19750

repair parts

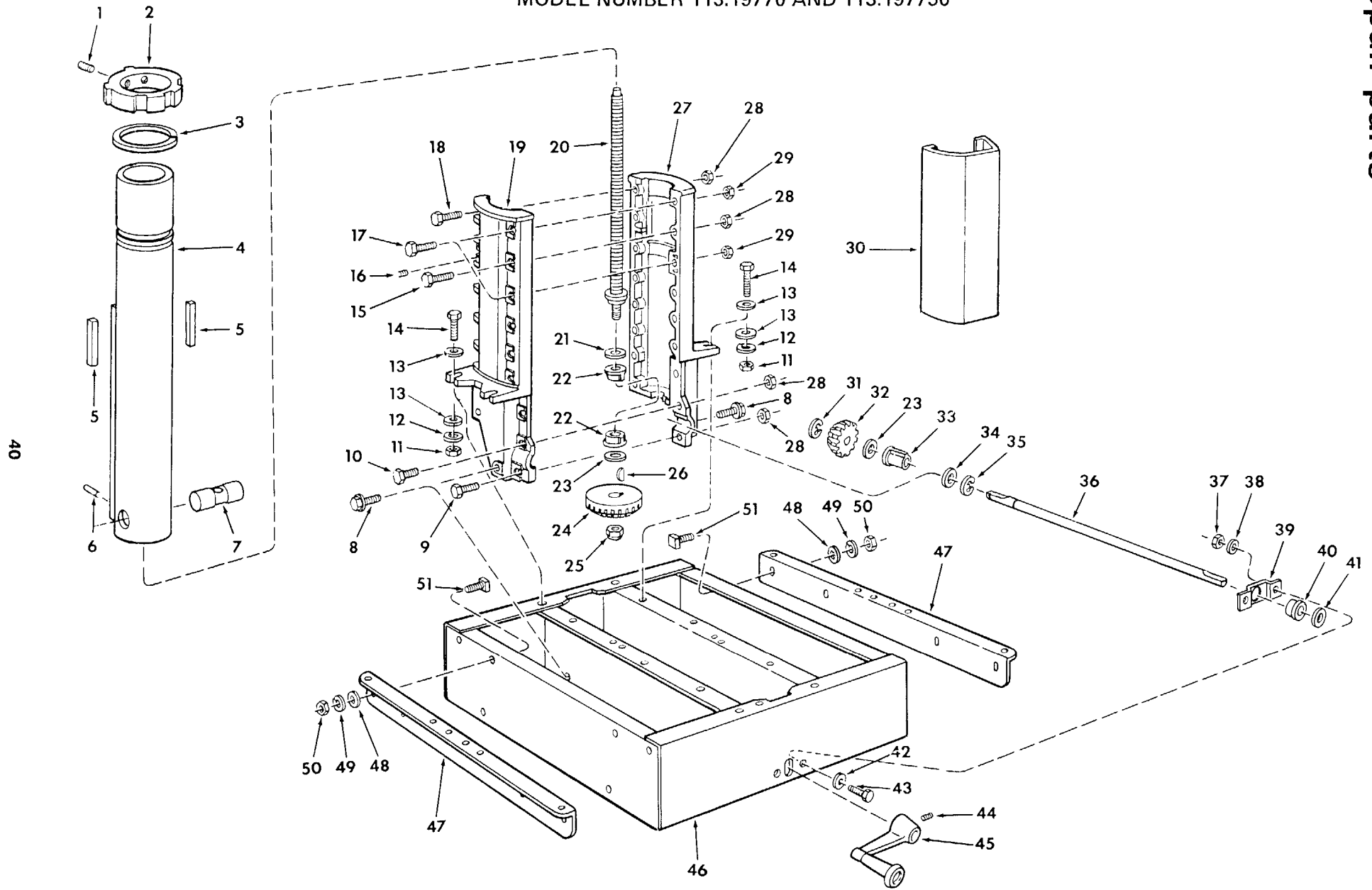

Figure 4

40

**PARTS LIST FOR CRAFTSMAN 10-INCH RADIAL SAW
MODEL NUMBER 113.19770 AND 113.197750**

FIGURE 4 – BASE ASSEMBLY

Key No.	Part No.	Description
1	STD 503705	*Screw, Soc. Set 3/8-16 x 1/2
2	63623	Latch, Arm
3	60330	Ring, Retaining 3"
4	63611	Tube Assembly
5	63610	Gib, Column Tube
6	STD 572510	*Pin, Roll 1/4 x 1
7	63612	Nut, Elevation
8	9416187	*Screw, Type "T" Hex Washer Hd. 5/16-18 x 3/4
9	STD 523110	*Screw, Hex Hd. 5/16-18 x 1
10	60078	*Screw, Hex Hd. 5/16-18 x 1/2
11	STD 541037	*Nut, Hex 3/8-16
12	STD 551137	*Lockwasher, 3/8
13	60340	*Washer, .380 x 7/8 x 1/8
14	STD 523712	*Screw, Hex Hd. 3/8-16 x 1-1/4
15	186648	*Screw, Hex Hd. 5/16-18 x 1-7/8
16	60329	Screw, Locking Set 1/4-20 x 3/8
17	60367	Bolt, Hex Hd. 5/16-18 x 1-7/8 High Strength
18	60336	Bolt, Hex Hd. 5/16-18 x 1-1/2 High Strength
19	63609	Support, L. H.
20	63613	Shaft Assembly, Elevating
21	63500	Washer, Thrust .502 x .927 x .031
22	63614	Bearing
23	60300	Washer, 1/2 x 7/8 x .010 (as required)
24	63615	Gear, Bevel
25	STD 541450	*Nut, Lock 1/2-13

Key No.	Part No.	Description
26	STD 580014	*Key, Woodruff 1/8 x 1/2
27	63619	Support, R. H.
28	STD 541031	*Nut, Hex 5/16-18
29	STD 541431	*Nut, Lock 5/16-18
30	63672	Trim, Column
31	STD 581037	*Ring, Retaining 3/8
32	63618	Gear, Pinion
33	63617	Bearing, Elevating Shaft
34	60080	Washer, .515 x .875 x .032
35	STD 581050	*Ring, Retaining 1/2
36	63616	Shaft, Elevating Crank
37	STD 541025	*Nut, 1/4-20
38	STD 551125	*Lockwasher 1/4
39	63622	Bracket, Bearing
40	63435	Bushing
41	60080	Washer, .515 x .875 x .032
42	STD 551012	*Washer, 17/64 x 9/16 x 3/64
43	STD 522505	*Screw, Hex Hd. 1/4-20 x 1/2
44	STD 502503	*Screw, Soc. Set 1/4-20 x 3/8
45	63434	Crank Assembly
46	63621	Base Assembly
47	63673	Channel, Table Mounting
48	STD 551031	*Washer, 11/32 x 7/8 x 1/16
49	STD 551131	*Lockwasher, 5/16
50	STD 541031	*Nut, Hex 5/16-18
51	109163	*Bolt, Square Hd. 5/16-18 x 3/4

*Standard Hardware Item – May be Purchased Locally.



repair parts

PARTS LIST FOR CRAFTSMAN 10-INCH RADIAL SAW MODEL NUMBER 113.19770 AND 113.197750

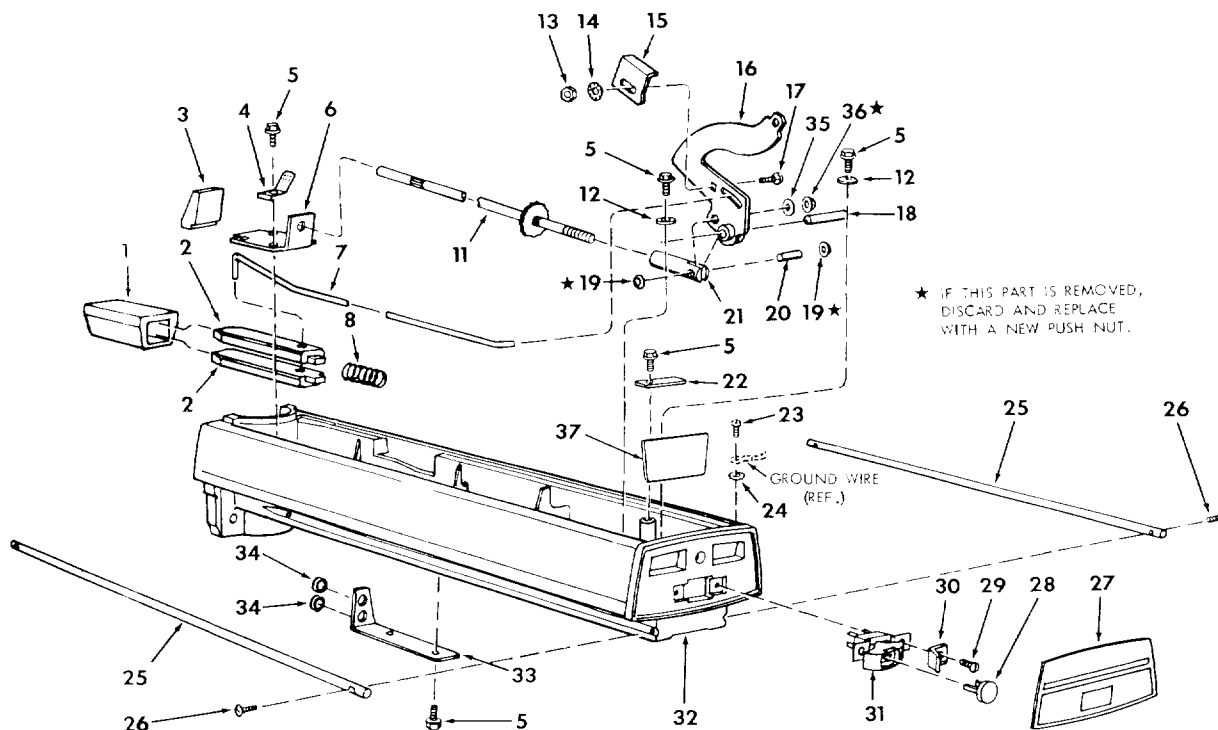

FIGURE 5 – ARM ASSEMBLY

Key No.	Part No.	Description
1	63626	Housing, Pin
2	63629	Pin, Arm Index
3	63631	Shoe, Arm Lock
4	63628	Spring, Tension
5	9420417	*Screw, Type "T" Hex Washer Hd. 1/4-20 x 5/8
6	63627	Guide
7	63632	Rod, Index
8	63630	Spring, Arm Lock
11	63633	Rod Assembly, Arm Lock
12	60332	Washer, 21/64 x 1 x 1/8
13	STD 541025	*Nut, Hex 1/4-20
14	STD 551225	*Lockwasher, External 1/4
15	63635	Bracket, Adjusting
16	63634	Lever Assembly
17	9417711	*Bolt, Rd. Hd. Short Square Neck 1/4-20 x 1/2
18	63638	Pin, Lever
19	60240	+Nut, Push 1/4

Key No.	Part No.	Description
20	63637	Pin
21	63636	Pin, Clevis
22	63667	Clamp, Cord
23	STD 601103	*Screw, Type "T" Pan Hd. 10-32 x 3/8
24	STD 551210	*Lockwasher, Ext. Tooth N10
25	63639	Track
26	448437	Screw, Type "T" Rd. Hd. 10-32 x 5/8
27	63680	Trim Front Arm
28	60256	Key
29	STD 600803	*Screw, Type "T" Pan Hd. 8-32 x 5/16
30	63664	Guard, Switch
31	63663	Switch, Locking (Includes Key No. 27)
32	63624	Arm, Radial
33	63640	Bracket, Support
34	60225	Grommet
35	60128	Washer, 17/64 x 5/8 x 1/32
36	60208	*Nut, Push
37	63773	Insulation

*Standard Hardware Item – May be Purchased Locally.

+If this part is removed, discard and replace with a new Push Nut.

PARTS LIST FOR CRAFTSMAN 10-INCH RADIAL SAW
MODEL NUMBER 113.19770 AND 113.197750

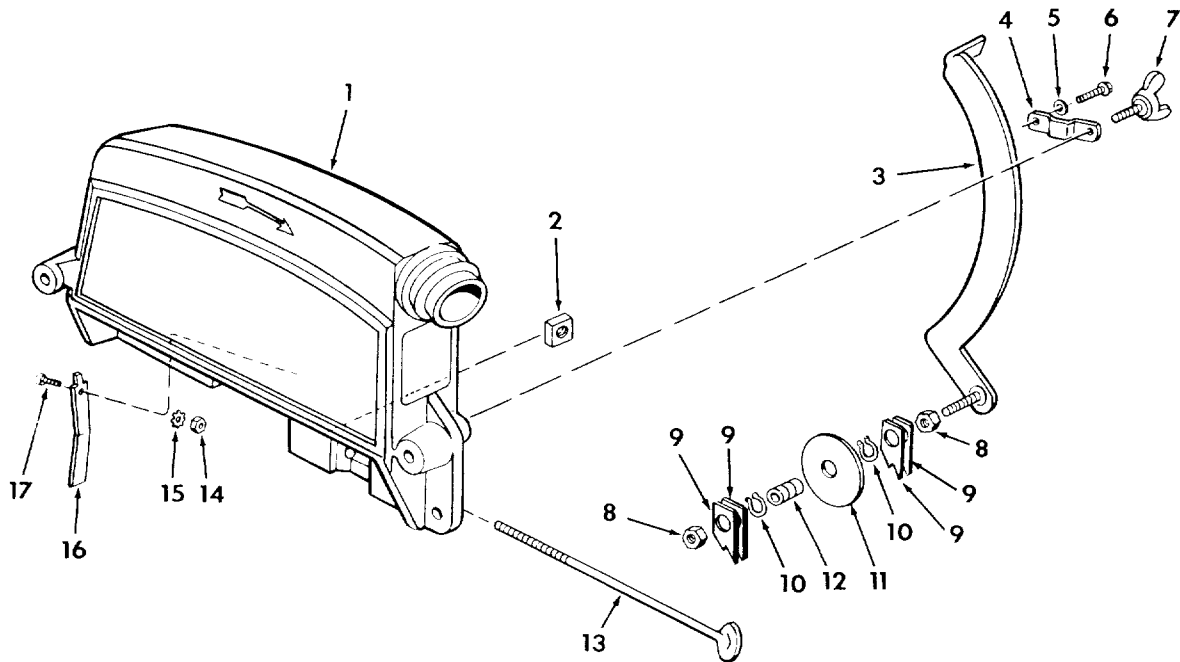

FIGURE 6 – GUARD ASSEMBLY

Key No.	Part No.	Description
1	63681	Guard
2	120399	*Nut, Square, 5/16-18
3	63541	Bar, Antikickback
4	63540	Guide, Antikickback
5	STD 551010	*Washer, 13/64 x 5/8 x 1/32
6	STD 601103	*Screw, Type "T" Pan Hd. 10-32 x 3/8
7	60219	Screw, Wing 5/16-18 x 1/2
8	STD 541231	*Nut, Hex., 5/16-18

Key No.	Part No.	Description
9	63271	Pawl, Anti-Kickback
10	STD 582043	*Ring, Retaining 7/16
11	63270	Spreader
12	63269	Bearing
13	63539	Screw, Guard Clamp
14	STD 541008	*Nut, Hex, 8-32
15	STD 551108	*Lockwasher, External Tooth No. 8
16	63538	Clamp, Guard
17	STD 510805	*Screw, Pan Hd., 8-32 x 1/2

*Standard Hardware Item – May be Purchased Locally.



**owners
manual**

SERVICE

MODEL NO.
113.19770
SAW ONLY
113.197750
SAW WITH LEGS

**HOW TO ORDER
REPAIR PARTS**

10-INCH RADIAL SAW

Now that you have purchased your 10-inch radial saw, should a need ever exist for repair parts or service, simply contact any Sears Service Center and most Sears, Roebuck and Co. stores. Be sure to provide all pertinent facts when you call or visit.

The model number of your 10-inch radial saw will be found on a label attached to your saw, at the front of the base.

WHEN ORDERING REPAIR PARTS, ALWAYS GIVE THE FOLLOWING INFORMATION:

PART NUMBER	PART DESCRIPTION
MODEL NUMBER	NAME OF ITEM
113.19770	10-INCH RADIAL SAW
113.197750	

All parts listed may be ordered from any Sears Service Center and most Sears stores. If the parts you need are not stocked locally, your order will be electronically transmitted to a Sears Repair Parts Distribution Center for handling.

Sold by SEARS, ROEBUCK AND CO., Chicago, IL. 60684 U.S.A.