

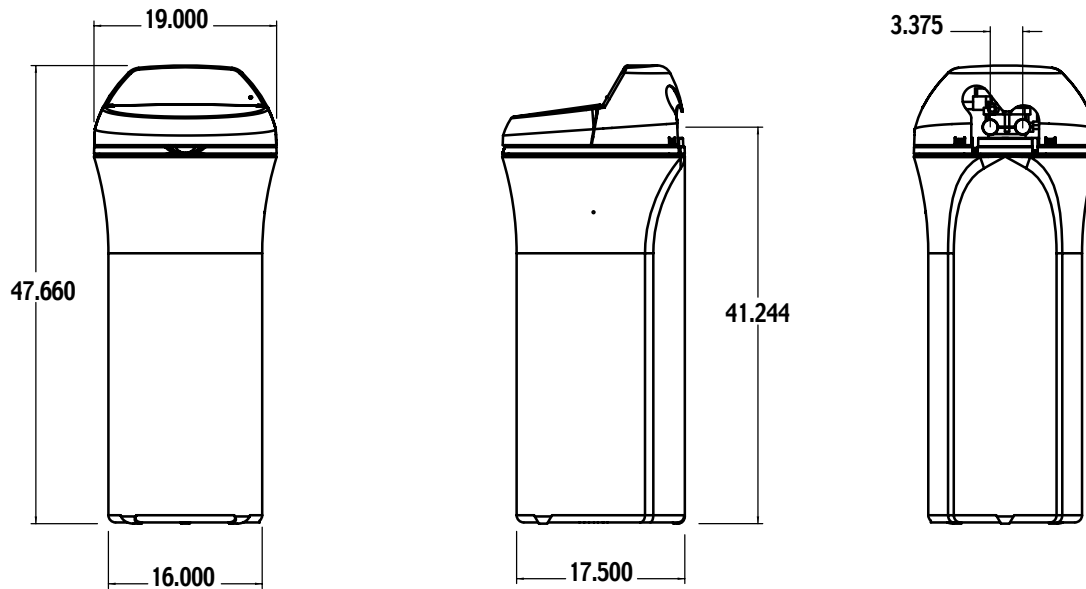

GE Appliances

GXSF30H – GE SmartWater™ Water Softening System



Salt Capacity – 200 lbs.

Important: All units must be installed according to local codes.

Note: Before installing, consult installation instructions packed with product for current dimensional data.



GNSH45E, GXSH39E and GXSF30H conform to ANSI/NSF 44 for specifically claimed performance.

**Specification Created 2/06
380215**

For answers to your Monogram®, GE Profile™ or GE appliance questions, visit our website at GEAppliances.com or call GE Answer Center® service, 800.626.2000.



GE Appliances

GXSF30H – GE SmartWater™ Water Softening System

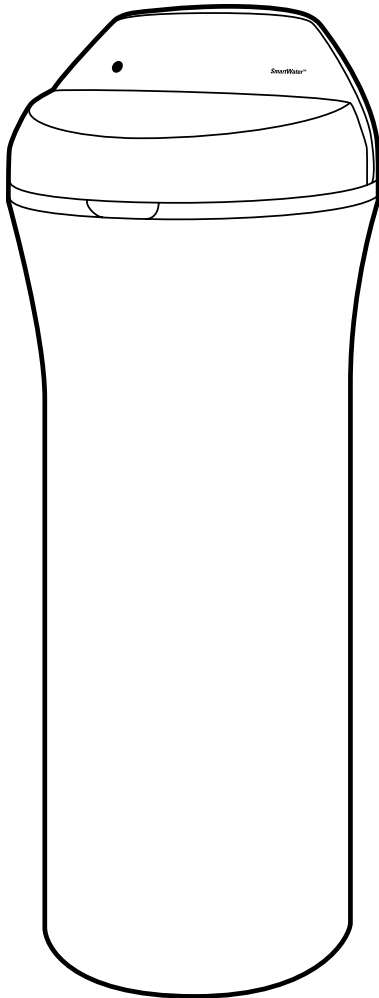

Features and Benefits

- Electronic Controls
- 30,200 Grain Capacity
- Efficiency (5120 gpg)
- Maximum Hardness Removal (95 gpg)
- Maximum Iron Reduction (4 ppm)
- Salt Capacity (200 lbs.)
- High flow valve system
- Permanent Settings Memory
- All parts needed for easy installation
- Model GXSF30H

**Specification Created 2/06
380215**