

**Sears**

*owners  
manual*

**MODEL NO.  
113.21371**

DRILL PRESS ONLY

**113.213710**

DRILL PRESS WITH  
1/2 HP MOTOR

Serial  
Number \_\_\_\_\_

Model and serial  
number may be found  
at the rear of the head.

You should record both  
model and serial number  
in a safe place for  
future use.

**CAUTION:**

Read **GENERAL**  
and **ADDITIONAL**  
**SAFETY**  
**INSTRUCTIONS**  
carefully

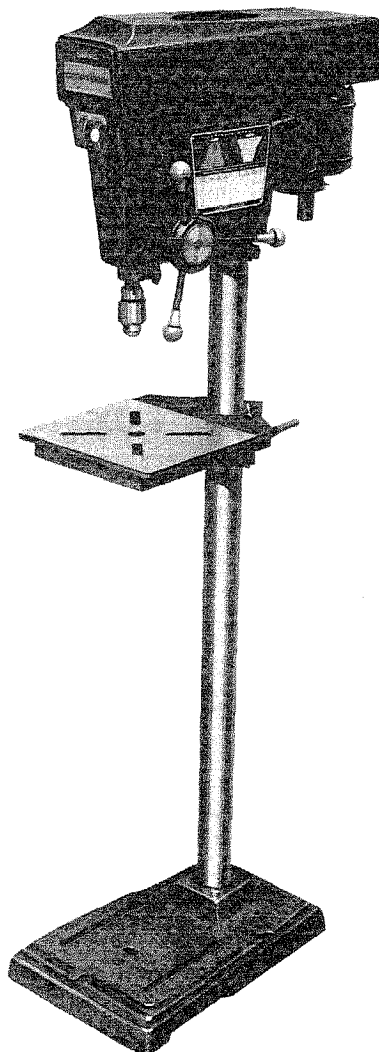

**Sears**

**CRAFTSMAN.**

**15-1/2 INCH  
DRILL PRESS**

- *assembly*
- *operating*
- *repair parts*

Sold by SEARS, ROEBUCK AND CO., Chicago, IL. 60684 U.S.A.

## FULL ONE YEAR WARRANTY ON CRAFTSMAN DRILL PRESS

If within one year from the date of purchase, this Craftsman Drill Press fails due to a defect in material or workmanship, Sears will repair it, free of charge.

WARRANTY SERVICE IS AVAILABLE BY SIMPLY CONTACTING THE NEAREST SEARS STORE OR SERVICE CENTER THROUGHOUT THE UNITED STATES.

This warranty gives you specific legal rights, and you may also have other rights which vary from state to state.

SEARS, ROEBUCK AND CO., Sears Tower, BSC 41-3, Chicago, IL 60684

# general safety instructions for power tools

## 1. KNOW YOUR POWER TOOL

Read the owner's manual carefully. Learn its application and limitations as well as the specific potential hazards peculiar to this tool.

## 2. GROUND ALL TOOLS

This tool is equipped with an approved 3-conductor cord and a 3-prong grounding type plug to fit the proper grounding type receptacle. The green conductor in the cord is the grounding wire. Never connect the green wire to a live terminal.

## 3. KEEP GUARDS IN PLACE

in working order, and in proper adjustment and alignment.

## 4. REMOVE ADJUSTING KEYS AND WRENCHES

Form habit of checking to see that keys and adjusting wrenches are removed from tool before turning it on.

## 5. KEEP WORK AREA CLEAN

Cluttered areas and benches invite accidents. Floor must not be slippery due to wax or sawdust.

## 6. AVOID DANGEROUS ENVIRONMENT

Don't use power tools in damp or wet locations or expose them to rain. Keep work area well lighted. Provide adequate surrounding work space.

## 7. KEEP CHILDREN AWAY

All visitors should be kept a safe distance from work area.

## 8. MAKE WORKSHOP KID-PROOF

— with padlocks, master switches, or by removing starter keys.

## 9. DON'T FORCE TOOL

It will do the job better and safer at the rate for which it was designed.

## 10. USE RIGHT TOOL

Don't force tool or attachment to do a job it was not designed for.

## 11. WEAR PROPER APPAREL

Do not wear loose clothing, gloves, neckties or jewelry (rings, wrist watches) to get caught in moving parts. Nonslip footwear is recommended. Wear protective hair covering to contain long hair. Roll long sleeves above the elbow.

## 12. USE SAFETY GOGGLES (Head Protection)

Wear Safety goggles (must comply with ANS Z87.1) at all times. Also, use face or dust mask if cutting operation is dusty, and ear protectors (plugs or muffs) during extended periods of operation.

## 13. SECURE WORK

Use clamps or a vise to hold work when practical. It's safer than using your hand, frees both hands to operate tool.

## 14. DON'T OVERREACH

Keep proper footing and balance at all times.

## 15. MAINTAIN TOOLS WITH CARE

Keep tools sharp and clean for best and safest performance. Follow instructions for lubricating and changing accessories.

## 16. DISCONNECT TOOLS

before servicing; when changing accessories such as blades, bits, cutters, etc.

## 17. AVOID ACCIDENTAL STARTING

Make sure switch is in "OFF" position before plugging in.

## 18. USE RECOMMENDED ACCESSORIES

Consult the owner's manual for recommended accessories. Follow the instructions that accompany the accessories. The use of improper accessories may cause hazards.

## 19. NEVER STAND ON TOOL

Serious injury could occur if the tool is tipped or if the cutting tool is accidentally contacted.

Do not store materials above or near the tool such that it is necessary to stand on the tool to reach them.

## 20. CHECK DAMAGED PARTS

Before further use of the tool, a guard or other part that is damaged should be carefully checked to ensure that it will operate properly and perform its intended function. Check for alignment of moving parts, binding of moving parts, breakage of parts, mounting, and any other conditions that may affect its operation. A guard or other part that is damaged should be properly repaired or replaced.

## 21. DIRECTION OF FEED

Feed work into a blade or cutter against the direction of rotation of the blade or cutter only.

## 22. NEVER LEAVE TOOL RUNNING UNATTENDED

Turn power off. Don't leave tool until it comes to a complete stop.

# additional safety instructions for drill presses

**WARNING: FOR YOUR OWN SAFETY, DO NOT ATTEMPT TO OPERATE YOUR DRILL PRESS UNTIL IT IS COMPLETELY ASSEMBLED AND INSTALLED ACCORDING TO THE INSTRUCTIONS . . . AND UNTIL YOU HAVE READ AND UNDERSTAND THE FOLLOWING:**

1. **General Safety Instructions for Power Tools** . . . Page 2
2. **Getting to Know Your Drill Press** . . . . . Page 13
3. **Basic Drill Press Operation** . . . . . Page 16
4. **Adjustments** . . . . . Page 17
5. **Maintenance** . . . . . Page 18

## 6. **Stability of Drill Press**

If there is any tendency for the drill press to tip over or move during certain operations such as shaping, the drill press should be bolted to the floor.

If the workpiece is too large to support with one hand, provide an auxiliary support.

## 7. **Location**

The drill press should be positioned so neither the operator nor a casual observer is forced to stand in line with a potential Kickback.

## 8. **Kickback**

A kickback occurs when the workpiece is suddenly thrown in the **OPPOSITE** direction to the **DIRECTION OF FEED; WHICH CAN CAUSE SERIOUS INJURY.**

Kickbacks are most commonly caused by:

- a. Relaxing your grip of the workpiece while shaping or routing.
- b. Taking too heavy a cut while shaping or routing.
- c. Ignoring the instructions for shaping or routing.

## 9. **Protection: Eyes, Hands, Face, Ears, Body**

**WARNING: FOR YOUR OWN SAFETY DON'T WEAR GLOVES WHEN OPERATING A DRILL PRESS**

- a. If any part of your drill press is malfunctioning, has been damaged or broken . . . such as the motor switch, or other operating control, a safety device or the power cord . . . cease operating immediately until the particular part is properly repaired or replaced.
- b. Wear safety goggles that comply with ANS Z87.1, and a face shield if operation is dusty. Wear ear plugs or muffs during extended periods of operation.
- c. Never place your fingers in a position where they could contact the drill or other cutting tool (router bit, shaper cutter, etc.) if the workpiece should unexpectedly shift. (For instance, hold-down/push blocks must be used when shaping on the drill press to keep hands remote from the cutter if a kickback should occur.)
- d. Never operate drill press with protective cover on the unused shaft end of the motor removed.
- e. Position workpiece to butt against the column whenever possible — if it is too short, clamp solidly to the Table — this is to prevent the drill bit from grabbing the work from your hands, which could result in personal injury. A drill press vise must be fastened to the table.
- f. Never perform any operation "free-hand" (hand-holding workpiece rather than support it on the Table), except wire brushing and polishing — **Wear Safety Goggles!**
- g. Never perform internal or curved shaping operations. Perform straight line shaping **ONLY** (with the Shaper Fence Accessory).

- h. Never perform any operation by moving the Head or Table with respect to one another. **Do not pull the motor switch "ON" or start any operation before checking that Head and Table Lock Handles are clamped tight to Column, and Head and Table Support Collars are correctly positioned.**
- i. Before pulling the motor switch "ON", be positive the belt guard is down, the Chuck is installed properly, and the drill or other cutting tool is securely clamped in the chuck.
- j. Before starting the operation, jog the motor switch to be sure the drill or other cutting tool does not have excessive runout or cause vibration.
- k. Do not operate the Drill Press unless the Depth Stop and Stop Nut are installed and the Depth Stop clamped to the Depth Stop Rod.
- l. Never pull out on the hub of the quill Hub Assembly unless you first grasp and support the Quill, otherwise the Quill will drop and damage may result.
- m. Use the spindle speed recommended for the specific operation and workpiece material — refer to panel on right side of the Head for drilling information, and for accessories, to the instruction sheets that accompany the accessories.
- n. If workpiece overhangs the Table such that it will fall to floor if unsupported, clamp it to the Table or provide auxiliary support.
- o. Use fixtures for unusual operations to adequately hold, guide and position workpiece for best quality and minimum hazard.
- p. Be sure to lock Quill securely for all routing, sanding, surfacing, shaping, and dovetailing operations.
- q. Never climb on the drill press Table.
- r. Lock the motor Switch and put away the Key when leaving the drill press.
- s. **DO NOT** perform layout, assembly, or setup work on the table while the cutting tool is rotating.

## 10. **Use only accessories designed for this drill press.**

- a. Holesaws must **NEVER** be operated on this drill press at a speed greater than 380 RPM.
- b. Drum sanders must **NEVER** be operated on this drill press at a speed greater than 720 RPM.
- c. Do not exceed the speed recommended for the drill size in wood when using the mortising bit and chisel.  
(See chart on R.H. trim panel of the drill press.)
- d. Do not install or use any drill that exceeds 7" in length or extends 6" below the chuck jaws.

## 11. **Note and Follow the Safety Rules that Appear on the Panel on the Left Side of the Head:**

<p><b>DANGER: FOR YOUR OWN SAFETY: READ AND UNDERSTAND OWNERS MANUAL BEFORE OPERATING THIS MACHINE. WEAR SAFETY GOGGLES. DO NOT WEAR GLOVES. SECURELY CLAMP WORK TO TABLE IF IT IS TOO SHORT TO CONTACT THE COLUMN WHEN IN OPERATING POSITION.</b></p>
--

## 12. **Think Safety.** Safety is a combination of operator common sense and alertness at all times when the drill press is being used.

**WARNING: DO NOT ALLOW FAMILIARITY (GAINED FROM FREQUENT USE OF YOUR DRILL PRESS) TO BECOME COMMONPLACE. ALWAYS REMEMBER THAT A CARELESS FRACTION OF A SECOND IS SUFFICIENT TO INFLICT SEVERE INJURY.**

# additional safety instructions for drill presses



The operation of any power tool can result in foreign objects being thrown into the eyes, which can result in severe eye damage. Always wear safety goggles complying with ANSI Z87.1 (shown on Package) before commencing power tool operation. Safety Goggles are available at Sears retail or catalog stores.

## unpacking and checking contents

### CONTENTS

	Page
General Safety Instructions for Power Tools . . . . .	2
Additional Safety Instructions for Drill Presses . . . . .	3
Unpacking and Checking Contents . . . . .	4
Table of Loose Parts . . . . .	4
Motor Specifications and Electrical Requirements . . . . .	5
Assembly . . . . .	6
Installing the Chuck . . . . .	6
Installing and Tensioning Belt. . . . .	12
Getting to Know Your Drill Press . . . . .	13
Belt Tension Rod . . . . .	13
Drilling Speed . . . . .	13
Drilling to Depth. . . . .	14
Removing the Chuck . . . . .	15
On-Off Switch . . . . .	15
Basic Drill Press Operation . . . . .	16
Installing Drills . . . . .	16
Positioning Table and Workpiece . . . . .	16
Feeding . . . . .	17
Adjustments . . . . .	17
Depth Scale . . . . .	17
Quill Return Spring . . . . .	17
Table and Head Lock Handles . . . . .	17
Maintenance . . . . .	18
Lubrication . . . . .	18
Recommended Accessories . . . . .	18
Trouble Shooting . . . . .	19
Repair Parts . . . . .	20

### TOOLS NEEDED

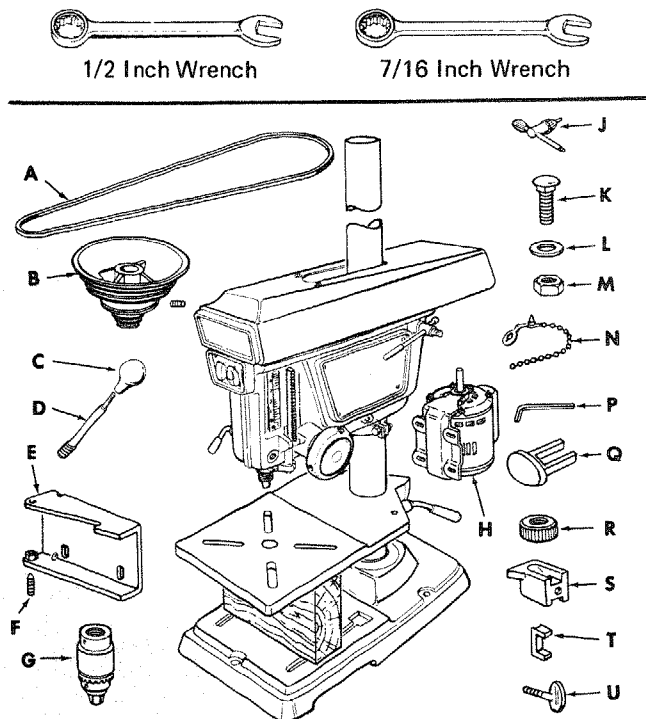

### TABLE OF LOOSE PARTS

Item	Description	Qty.
A	Belt, V . . . . .	1
B	Pulley, Motor (w/Set Screw) . . . . .	1
C	Knob . . . . .	3
D	Rod . . . . .	3
E	Mount, Motor . . . . .	1
F	Screw, Set (Cone Pt. 5/16-18 x 1-1/4) . . . . .	2
G	Chuck, Drill . . . . .	1
H	Motor, 1/2 HP 1725 RPM . . . . .	1
	(Model 113.213710 Only)	
	Bag of Miscellaneous Small Parts, Pt. #71175	
	Consisting of the Following:	
J	Key, Drill Chuck . . . . .	1
K	Carriage Bolt (5/16-18 x 3/4) . . . . .	4
L	Washer (11/32) . . . . .	4
M	Nut, Hex (5/16-18) . . . . .	6
N	Tie, Wire . . . . .	1
P	Set Screw Wrench (5/32 inch) . . . . .	1
Q	Key, Switch . . . . .	2
R	Nut, Stop . . . . .	1
S	Pointer, Depth Gage . . . . .	1
T	Shoe, Depth Gage . . . . .	1
U	Screw, Thumb . . . . .	1

### UNPACKING AND CHECKING CONTENTS

Model No. 113.21371 is shipped complete in one carton but does not include a motor.

Model No. 113-213710 is shipped complete in one carton and includes a 1/2 HP 1725 RPM motor.

Separate all parts from packing materials and check each one with the "Table of Loose Parts" to make certain all items are accounted for, before discarding any packing material.

If any parts are missing, do not attempt to assemble the drill press, plug in the power cord or turn the switch on until the missing parts are obtained and installed correctly.

Remove the protective oil that is applied to the table and column. Use any ordinary household type grease and spot remover.

**CAUTION:** Never use gasoline, naphtha or similar highly volatile solvents.

Apply a coat of automobile wax to the table.  
Wipe all parts thoroughly with a clean dry cloth.

# motor specifications and electrical requirements

## MOTOR SPECIFICATIONS

This drill press is designed to use a 1725 RPM motor only. Do not use any motor that runs faster than 1725 RPM. It is wired for operation on 110-120 volts, 60 Hz., alternating current. **IT MUST NOT BE CONVERTED TO OPERATE ON 230 VOLTS, EVEN THOUGH THE RECOMMENDED MOTORS ARE DUAL VOLTAGE.**

**THESE CRAFTSMAN MOTORS HAVE BEEN FOUND TO BE ACCEPTABLE FOR USE ON THIS TOOL.**

HP	RPM	VOLTS	CATALOG NO.
1/3	1725	110-120	1250
1/2	1725	110-120	1254
1/2	1725	110-120	1255
1/2	1725	110-120	1278
1/2	1725	110-120	1279

**CAUTION: Do not use blower or washing machine motors or any motor with an automatic reset overload protector as their use may be hazardous.**

## CONNECTING TO POWER SOURCE OUTLET

This machine must be grounded while in use to protect the operator from electric shock.

Plug power cord into a 110-120V properly grounded type outlet protected by a 15-amp. time delay or Circuit-Saver fuse or circuit breaker.

**IF YOU ARE NOT SURE THAT YOUR OUTLET IS PROPERLY GROUNDED, HAVE IT CHECKED BY A QUALIFIED ELECTRICIAN.**

**WARNING: DO NOT PERMIT FINGERS TO TOUCH THE TERMINALS OF PLUGS WHEN INSTALLING OR REMOVING THE PLUG TO OR FROM THE OUTLET.**

**WARNING: IF NOT PROPERLY GROUNDED THIS POWER TOOL CAN INCUR THE POTENTIAL HAZARD OF ELECTRICAL SHOCK, PARTICULARLY WHEN USED IN DAMP LOCATIONS, IN PROXIMITY TO PLUMBING. IF AN ELECTRICAL SHOCK OCCURS THERE IS THE POTENTIAL OF A SECONDARY HAZARD SUCH AS YOUR HANDS CONTACTING THE CUTTING TOOL.**

If power cord is worn or cut, or damaged in any way, have it replaced immediately.

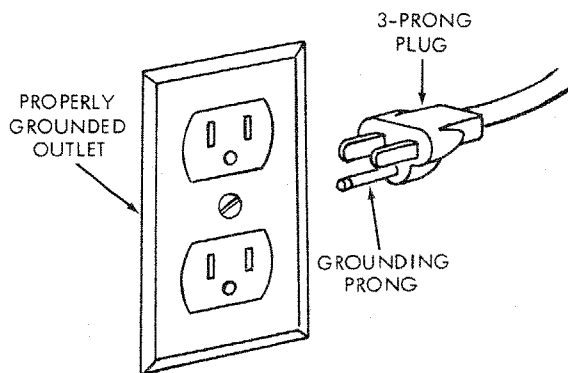

If your unit is for use on less than 150 volts, it has a plug that looks like above.

This power tool is equipped with a 3-conductor cord and grounding type plug which has a grounding prong, approved by Underwriters' Laboratories and the Canadian Standards Association. The ground conductor has a green jacket and is attached to the tool housing at one end and to the ground prong in the attachment plug at the other end.

This plug requires a mating 3-conductor grounded type outlet as shown.

If the outlet you are planning to use for this power tool is of the two prong type **DO NOT REMOVE OR ALTER THE GROUNDING PRONG IN ANY MANNER.** Use an adapter as shown and always connect the grounding lug to known ground.

It is recommended that you have a qualified electrician replace the TWO prong outlet with a properly grounded THREE prong outlet.

An adapter as shown below is available for connecting plugs to 2-prong receptacles. The green grounding lug extending from the adapter must be connected to a permanent ground such as to a properly grounded outlet box.

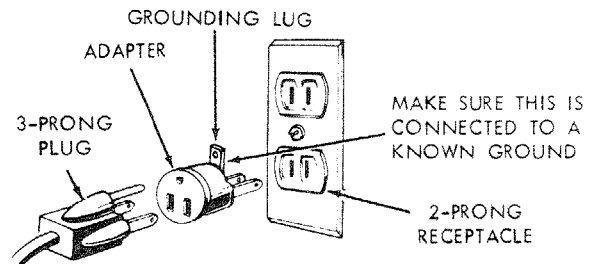

**NOTE:** The adapter illustrated is for use only if you already have a properly grounded 2-prong receptacle. Adapter is not allowed in Canada by the Canadian Electrical Code.

The use of any extension cord will cause some loss of power. To keep this to a minimum and to prevent over-heating and motor burn-out, use the table below to determine the minimum wire size (A.W.G.) extension cord. Use only 3 wire extension cords which have 3 prong grounding type plugs and 3-pole receptacles which accept the tools plug.

Extension Cord Length	Wire Size A.W.G.
Up to - 100 Ft.	16
100 - 200 Ft.	14
200 - 400 Ft.	10

## CHECK MOTOR ROTATION

**WARNING: FOR YOUR OWN SAFETY, MAKE SURE PLUG IS NOT CONNECTED TO POWER SOURCE OUTLET. WHEN CHANGING MOTOR ROTATION.**

The motor must rotate **CLOCKWISE** when viewed from the shaft end to which you will mount the pulley.

If it does not, change the direction according to the instructions furnished with the motor.

# assembly

**WARNING: FOR YOUR OWN SAFETY, NEVER CONNECT PLUG TO POWER SOURCE OUTLET UNTIL ALL ASSEMBLY STEPS ARE COMPLETED.**

1. Unwind the power cord.
2. Make sure the quill lock handle is tight.
3. Stand on the left side of the drill press and **LOOSEN** the **HEAD LOCK HANDLE**.
4. Raise the **HEAD** about **HALF WAY** up the column.

**CAUTION: THE HEAD WEIGHS ABOUT 65 POUNDS DROPPING THE HEAD ACCIDENTLY COULD CAUSE PERSONAL INJURY OR DAMAGE THE DRILL PRESS.**

5. **TIGHTEN** the Head Lock Handle.
6. Position the **HEAD-SUPPORT COLLAR** underneath the head and tighten the **TWO BOLTS** using a  $\frac{1}{2}$ " wrench.

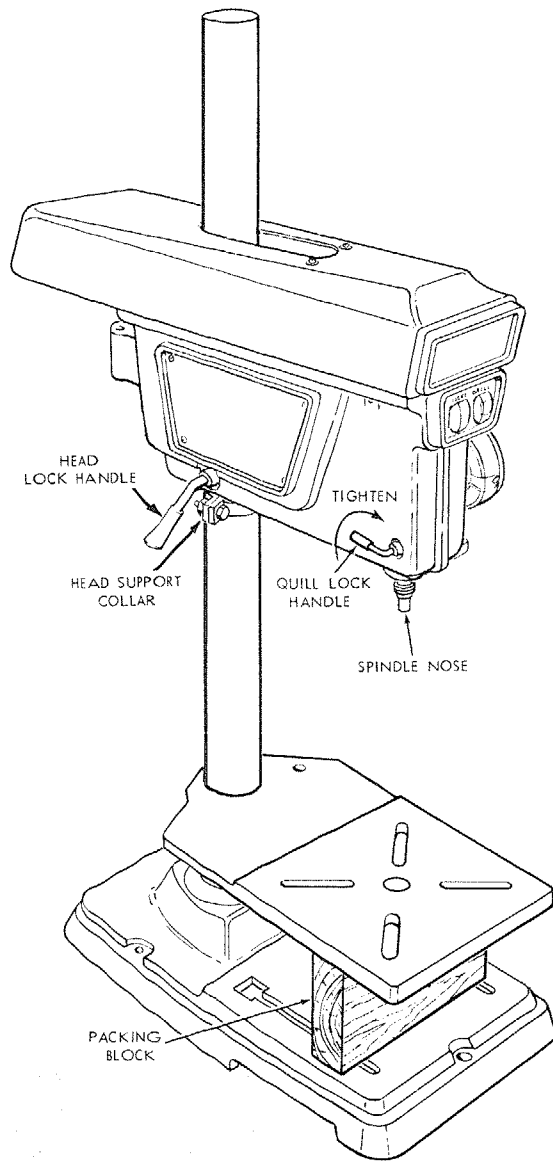

IN ORDER TO RAISE THE HEAD TO A HIGHER POSITION, IT WILL BE NECESSARY TO INSTALL SEVERAL PARTS.

## INSTALLING THE CHUCK

1. Clean out the **TAPERED HOLE** in the chuck; clean the spindle nose with a clean cloth. Make sure there are no foreign particles sticking to the surfaces. The slightest piece of dirt on the spindle nose or in the chuck will prevent the chuck from seating properly. This will cause the drill to "wobble."

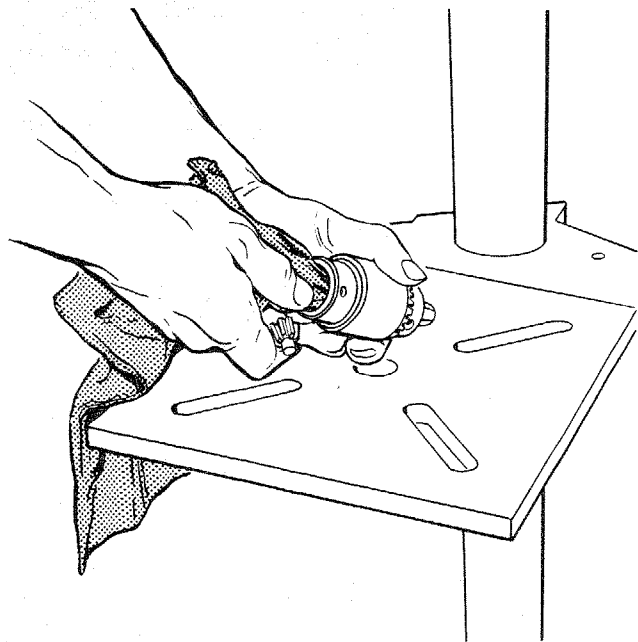

2. Apply a light film of oil such as Sears household oil to the spindle nose.
3. Place the chuck on the spindle nose and screw the locking collar up as far as it will go.

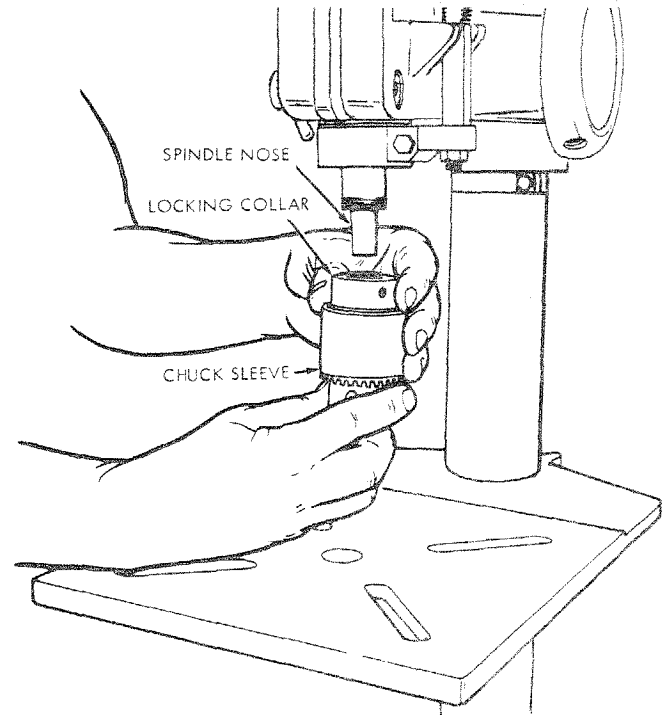

4. Insert a piece of 1/4" dia. STEEL ROD in to one of the holes in the chuck body.
5. Insert the CHUCK KEY into one of the holes in the collar . . . TURN IT IN THE DIRECTION OF ARROW UNTIL IT IS TIGHT.
6. To remove chuck, turn the collar in the opposite direction until the chuck is ejected from the spindle.

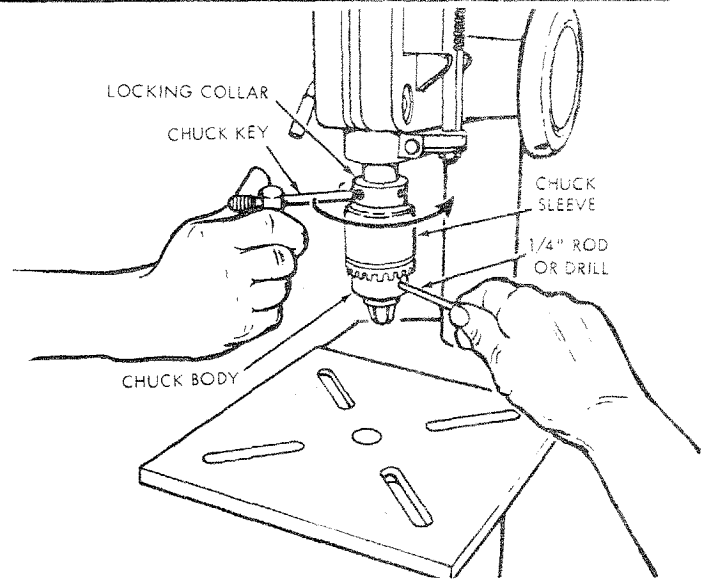

### INSTALLING FEED HANDLES

1. Screw a FEED HANDLE into each of the threaded holes in the hub, and tighten.

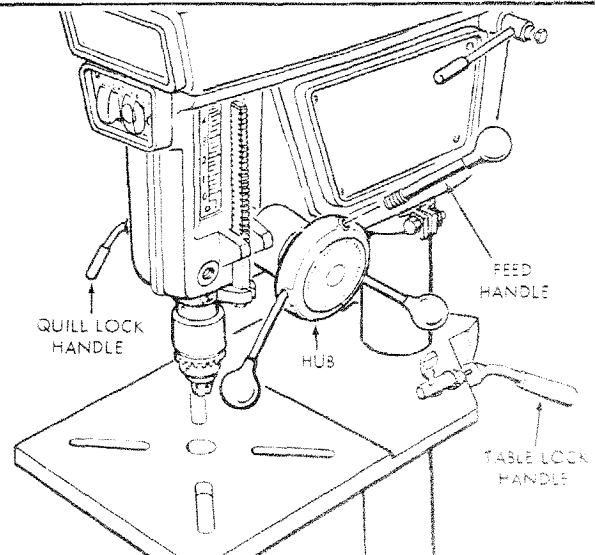

# assembly

## INSTALLING THE DEPTH STOP

1. Screw the THUMB SCREW partways into the DEPTH POINTER.
2. Place the DEPTH POINTER SHOE inside the pointer.
3. Loosen QUILL LOCK HANDLE ... lower the quill about two inches.
4. Slide the pointer and shoe onto the FEED STOP ROD and tighten the thumb screw. Make sure the pointer is positioned as shown.
5. Screw the FEED STOP NUT onto the top of the feed stop rod.
6. Move the pointer upwards against the nut and tighten the thumb screw.
7. Tighten QUILL LOCK HANDLE.

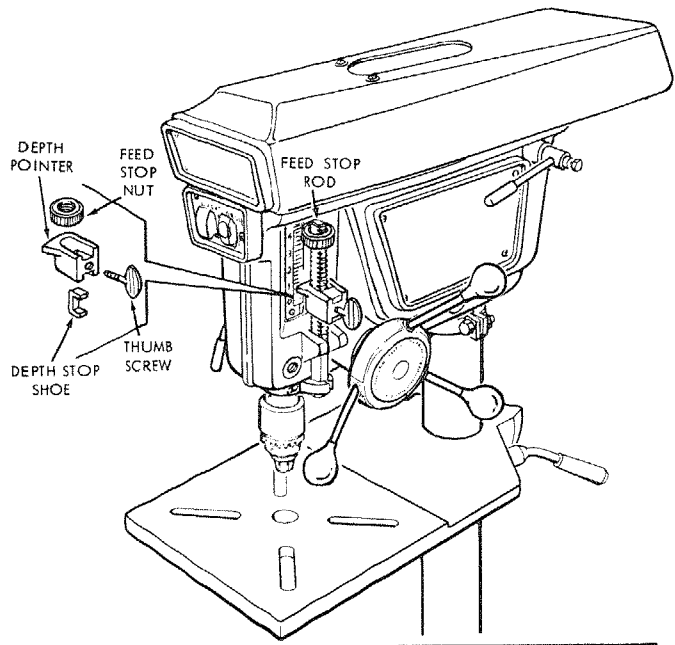

## RAISING THE HEAD

1. Loosen the TABLE LOCK HANDLE.
2. Place a piece of WOOD on the table. USE THE packing block.
3. Turn the CHUCK SLEEVE until the jaws are all the way up inside the chuck.
4. Raise the table until the wood block touches the chuck body.
5. Tighten the Table Lock Handle.
6. Locate the two clamps and bolts that you removed from the paper tube when you first started unpacking your drill press. These parts make up the TABLE SUPPORT COLLAR. Position the TABLE SUPPORT COLLAR underneath the table and tighten the bolts.
7. Loosen the HEAD LOCK HANDLE.
8. Loosen the QUILL LOCK HANDLE.

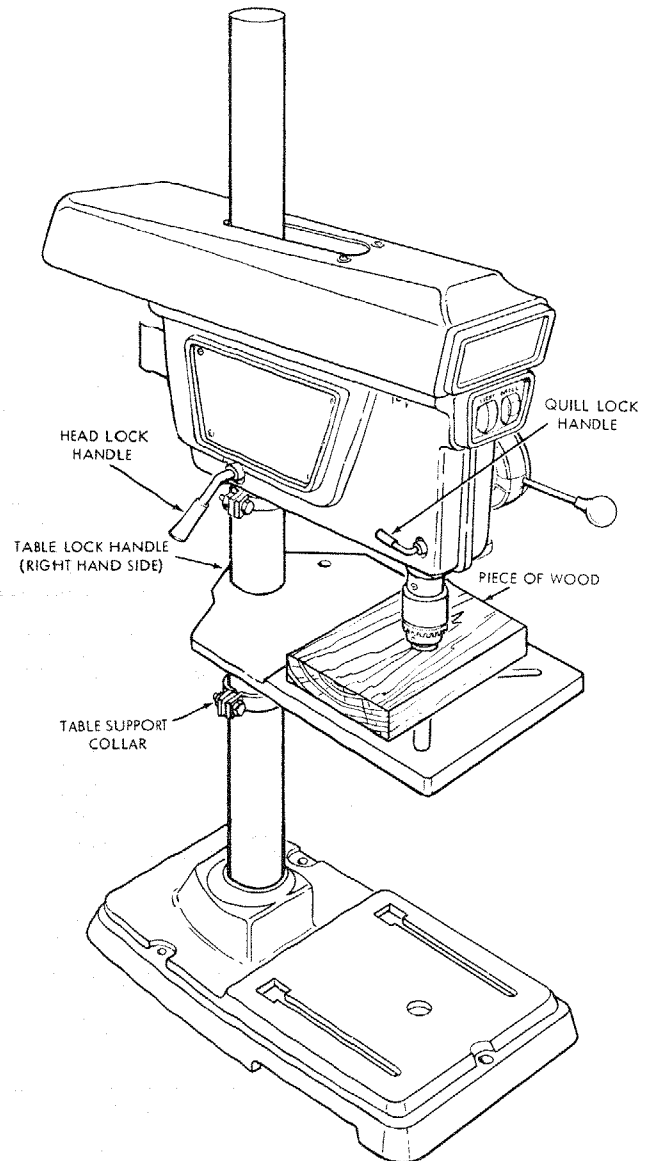



9. Gently push down on the FEED HANDLES until the head raises upwards as far as it will go.
10. TIGHTEN THE HEAD LOCK HANDLE AND THE QUILL LOCK HANDLE.
11. HOLD onto the Feed Handle and UNLOCK the quill lock handle.
12. Let the quill return to the UP position in the head.
13. TIGHTEN THE QUILL LOCK HANDLE.

Repeat steps 3 thru 10 until the head is raised to the desired position. Position HEAD SUPPORT COLLAR underneath the head and tighten the bolts.

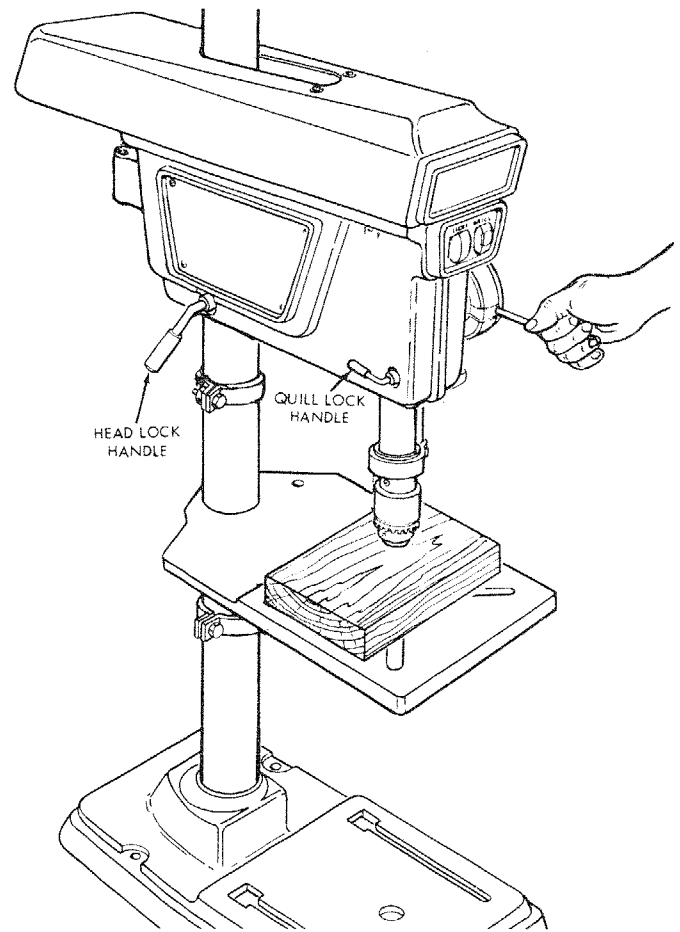

**CAUTION:** Do not raise the head above the top of the column.

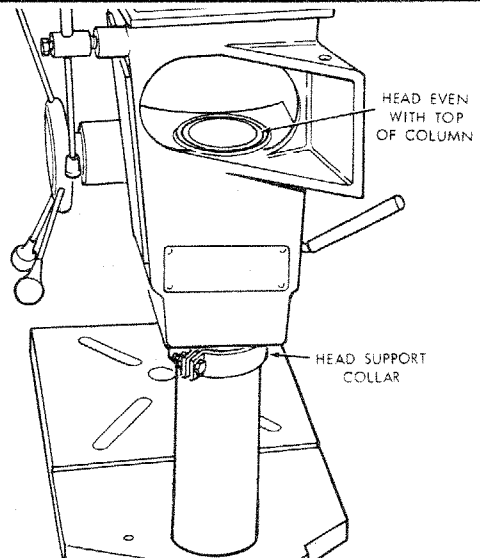

### INSTALLING MOTOR PULLEY

When using a double shaft motor, remove the KEY from the 5/8 in. dia. shaft.

1. Using a 5/32 in. setscrew wrench, UNSCREW the setscrew in the pulley so that it is clear of the KEYWAY (GROOVE).
2. Place the pulley on the shaft. Make sure it slips on EASILY . . . don't FORCE it. Remove any burrs in the pulley or on the shaft if any.
3. Position the pulley so that the KEYWAYS in the shaft and in the pulley line up; and the small end of the pulley is about 1/16 of an inch away from the motor.

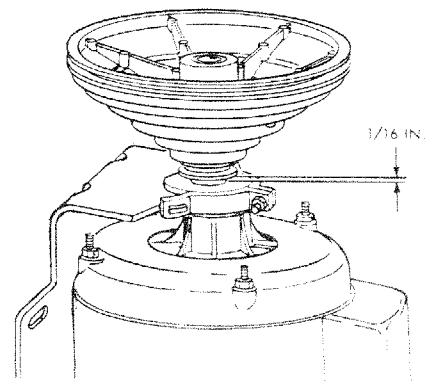

# assembly

**NOTE:** When using motors which have  $\frac{1}{2}$ " dia. shafts, place the adapter sleeve (furnished with the motor) on the shaft so that the slot in the sleeve is over the flat spot.

4. Insert the shaft key (furnished with motor) into the grooves in the shaft and pulley so that the end of the key is even with the end of the shaft.
5. Tighten the set screw. Use a pair of pliers on the short end of the set screw wrench for increased leverage.

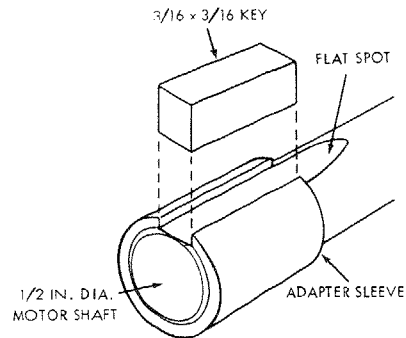

## MOUNTING THE MOTOR

1. Position the motor mount as shown and place the motor on top of it.
2. Find four  $\frac{5}{16}$  in.—18 x 1 in. CARRIAGE BOLTS, flat washers and hex. nuts, among the loose parts.

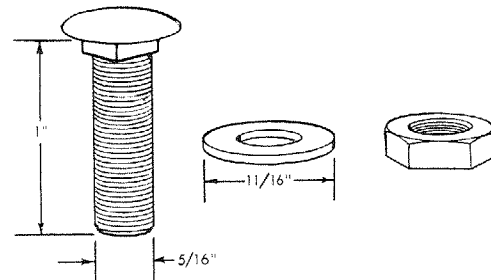

3. Insert the bolts as shown . . . install washers . . . screw on nuts but **DON'T TIGHTEN** them.

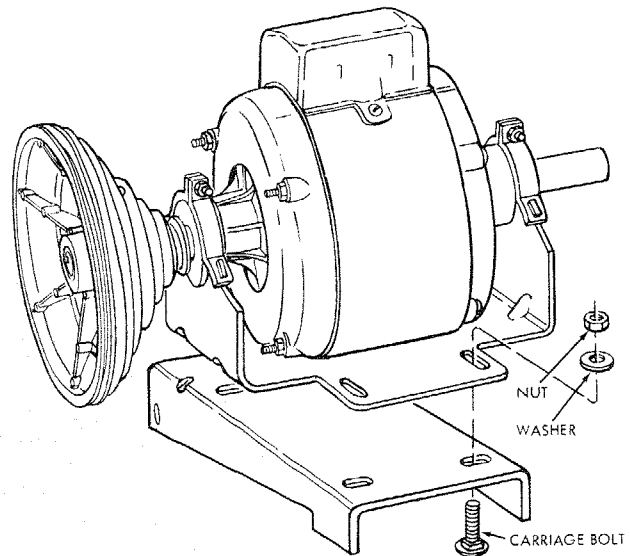

4. Using a  $\frac{5}{32}$  inch set screw wrench unscrew the PIVOT screws as shown.

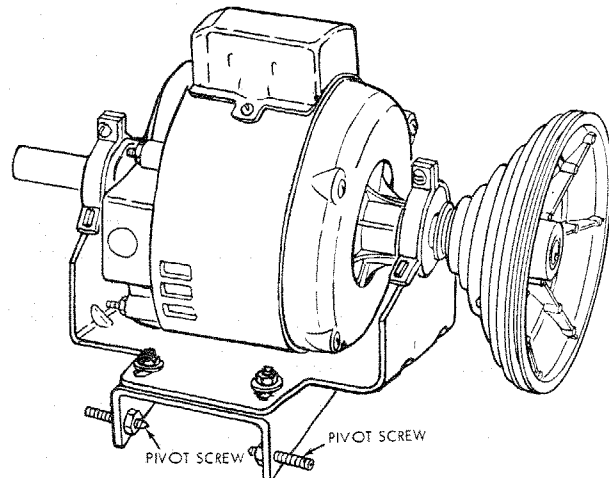

5. Remove the belt guard by "pushing in" on the two "links".

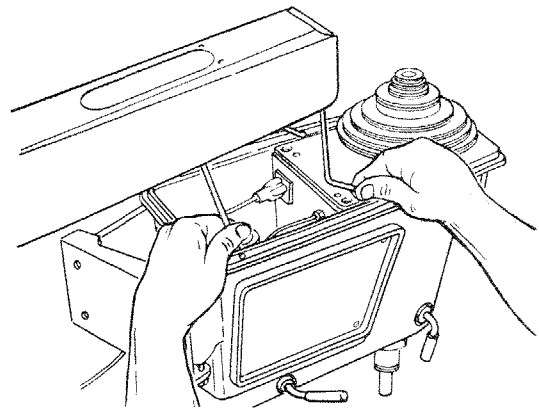

6. Place motor on drill press ... screw the pivot screws into the holes.

**NOTE: DO NOT SCREW THEM IN TOO TIGHT ... EXCESSIVE TIGHTNESS COULD BEND THE MOTOR MOUNT.**

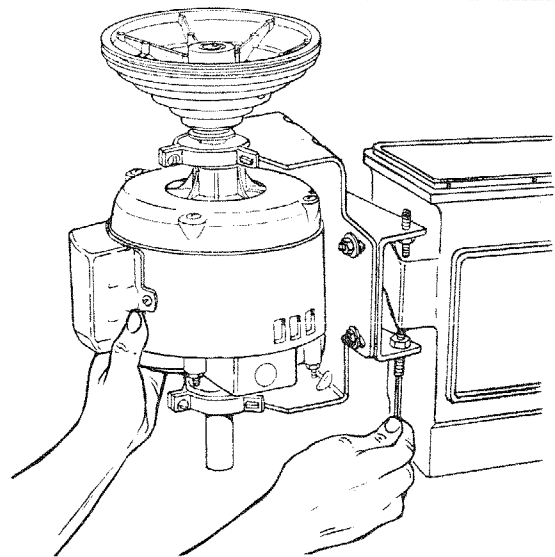

7. Find two 5/16 in-18 hex. nuts among the loose parts ... screw them on to the pivot screws ... tighten them with a 1/2 in. wrench while preventing the pivot screws from turning.
8. Plug motor cord into outlet inside of drill press.

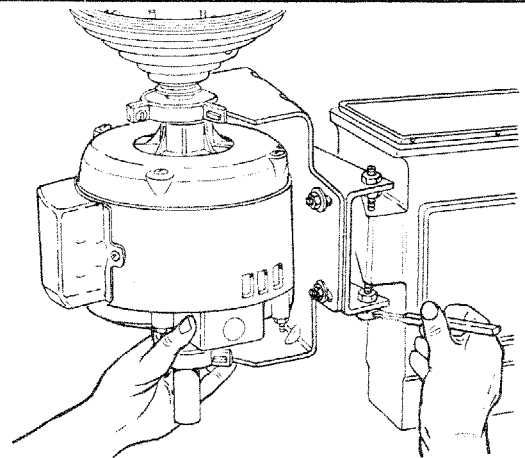

9. Find the plastic CORD TIE among the loose parts ... insert the pointed end into the hole in the motor mount.
10. Gather up the slack in the motor cord ... wrap the CORD TIE around it ... insert one end of the TIE into the hole in the other end. Pull it tightly to secure the cord to the motor mount.

**CAUTION: If you are using a DOUBLE SHAFT motor. Make sure the SHAFT PROTECTOR is installed. NEVER USE THE DRILL PRESS WITH THE UNUSED SHAFT EXPOSED.**

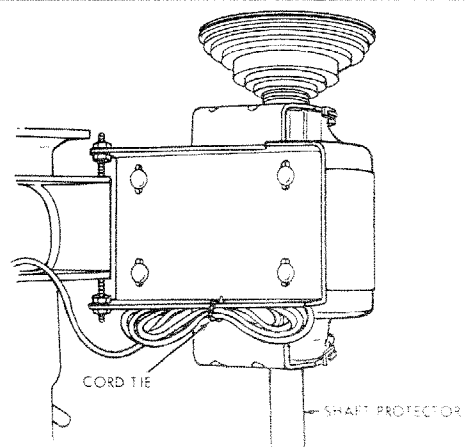

# assembly

## INSTALLING AND TENSIONING BELT

1. Place a straightedge such as a piece of wood, metal or framing square across the pulleys.
2. Move the motor UPWARDS until the pulleys are IN LINE . . . tighten the motor mounting nuts with a  $\frac{1}{2}$  in. wrench.

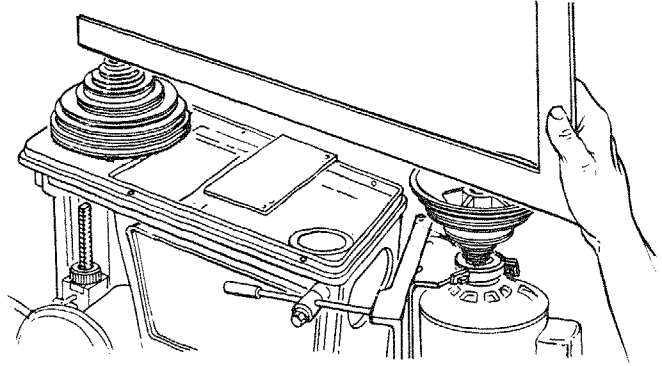

3. Place the belt on the pulleys.
4. Put a dab of grease such as Sears gear case lubricant on the rubber tip of the BELT TENSIONING ROD.
5. Loosen HEX HEAD SCREW with a  $\frac{7}{16}$  in. wrench . . . position BELT TENSIONING ROD as shown.
6. Push the motor to the right with moderate pressure while pushing THE BELT TENSIONING rod against the motor mount . . . TIGHTEN the HEX SCREW.
7. If belt slips while drilling, readjust belt tension.
8. Replace the belt guard.

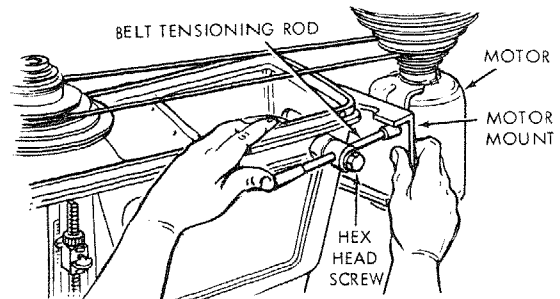

## INSTALLING LIGHT BULB

1. Install a light bulb (not larger than 60 watt) into the socket inside the head.

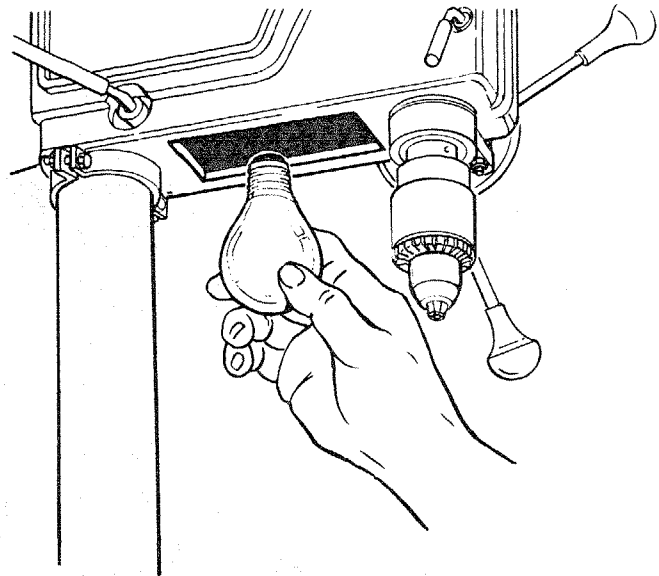

# getting to know your drill press

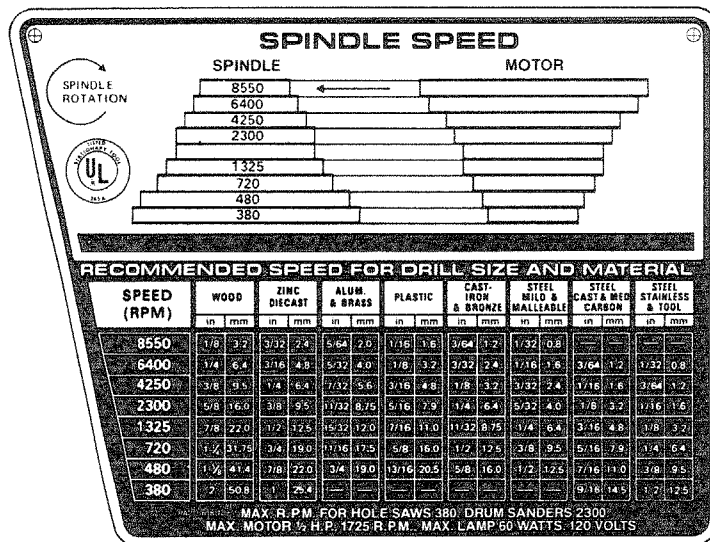
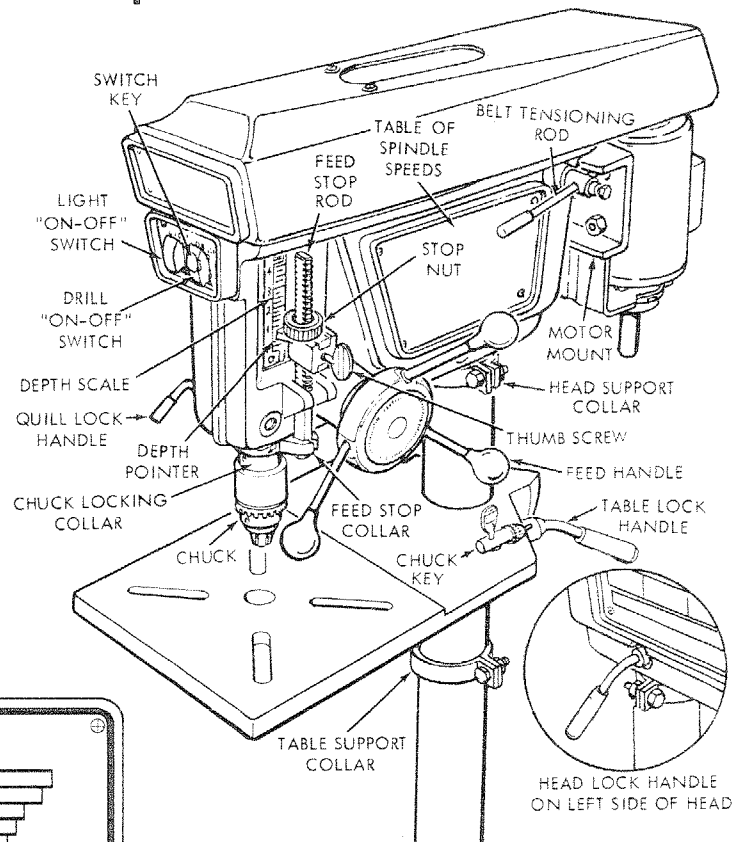
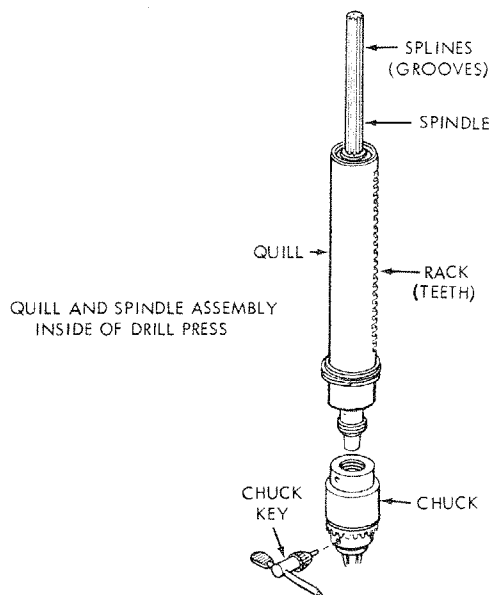

← SPINDLE SPEED CHART

**BELT TENSION ROD . . .** maintains constant tension on the belt, TO RELEASE belt tension for changing speeds, push the GRIP of the rod up.

To APPLY belt tension, PUSH the MOTOR to the REAR while pulling DOWN on the GRIP of the rod. Belt should only be tight enough so that it does not slip. If belt slips while drilling, readjust belt tensioning rod

**FEED HANDLES . . .** are for moving the quill up or down. One or two may be removed if necessary whenever the workpiece is of such unusual shape that it interferes with the handles.

Although there is a rubber cushion between the FEED STOP COLLAR and the head, NEVER let go of the feed handles when you have finished drilling a hole.

Hold on to the handle while allowing the quill to return to the UP position.

**DRILLING SPEED . . .** Can be changed by placing the belt in any of the STEPS (grooves) in the pulleys. See Spindle Speed chart on right side of Head.

To determine the approximate drilling speed, refer to the table on the RIGHT side of the drill press head. For example to drill a 5/8 inch hole in wood, the belt is placed in the FOURTH step from the top. The speed will then be 2300 RPM (revolutions per minute).

**QUILL LOCK . . .** Holds the quill at any desired point within its travel.

To lock the quill requires only moderate pressure on the lock handle.

**FEED STOP NUT** limits the downward movement of the quill at any desired point within its travel, and prevents the pointer from moving upward.

The DEPTH POINTER is locked in place with the THUMBSCREW.

# getting to know your drill press

**HEAD LOCK HANDLE** . . . locks the head to the column. ALWAYS have it locked in place while operating the drill press.

**HEAD SUPPORT COLLAR** . . . prevents the head from dropping when the head lock handle is loosened.

ALWAYS have the collar LOCKED into position against the UNDERSIDE of the head.

**TABLELOCK HANDLE** . . . locks the table to the column.

ALWAYS have it locked in place while operating the drill press.

ALWAYS hold the table while unlocking it.

**TABLE SUPPORT COLLAR** . . . Prevents the table from

accidentally dropping all the way to the bottom when the table lock handle is loosened.

ALWAYS have the collar LOCKED into position approximately 34 in. from the floor for average drilling operations.

**CHUCK KEY** . . . is used to tighten or loosen the chuck. It has a spring loaded EJECTOR pin to "pop" it out of the chuck when you let go of it. When not in use, ALWAYS store the key in the hole in the table.

**CHUCK LOCKING COLLAR** . . . draws the chuck onto the spindle nose.

It prevents the chuck from coming loose during operation. ALWAYS have the collar tightened.

---

## DRILLING TO DEPTH

To drill a BLIND hole (not all the way through) to a given depth, can be done two ways.

1. Mark the depth of the hole on the side of the workpiece.
2. With the switch OFF bring the drill down until the TIP or lips are even with the MARK . . . LOCK the QUILL.
3. Move the POINTER all the way down and tighten the thumb screw.
4. Tighten the STOP NUT against the pointer.
5. Unlock the quill.
6. Feed the drill into the workpiece until it is stopped by the pointer.

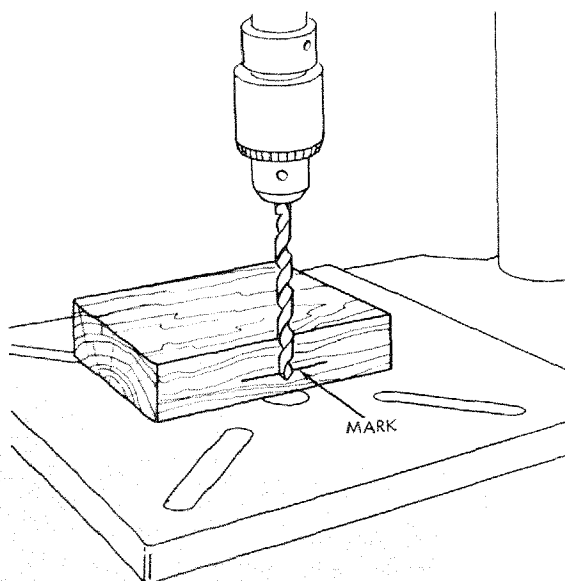

---

## ANOTHER WAY—

1. With the switch OFF, bring the drill down until the TIP touches the TOP of the WORKPIECE . . . lock the quill.
2. Set the POINTER to the desired DEPTH . . . lock it and TIGHTEN the STOP NUT against it. For example . . . if you want to drill a hole one inch deep . . . set the pointer at the one inch mark in the scale.

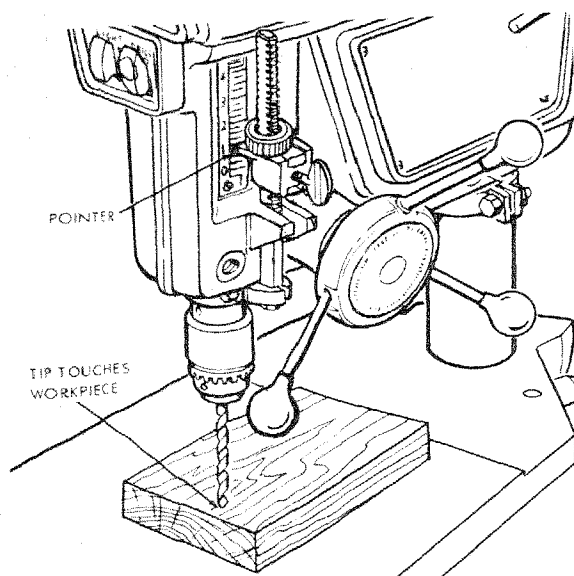

## REMOVING THE CHUCK.

1. Insert a piece of 1/4 in. dia. steel rod in one of the holes in the chuck body.
2. Insert the CHUCK KEY into one of the holes in the collar ... turn it in the direction of arrow until LOOSE. Continue to turn it until the chuck is released.

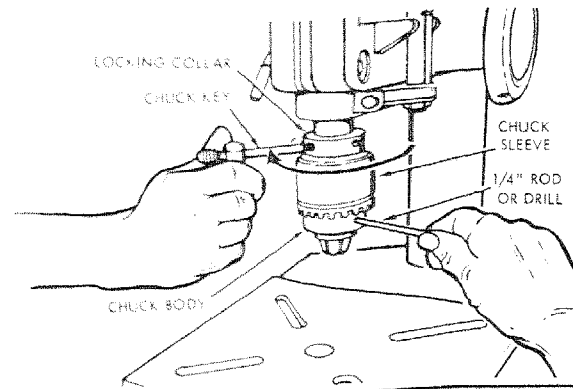

“ON-OFF” SWITCH for drill has locking feature. THIS FEATURE IS INTENDED TO PREVENT UNAUTHORIZED AND POSSIBLE HAZARDOUS USE BY CHILDREN AND OTHERS.

“ON-OFF” SWITCH for light is independent of the drill switch. This permits the light to be “on” while making your setups.

Insert KEY into switch. NOTE: Key is made of yellow plastic.

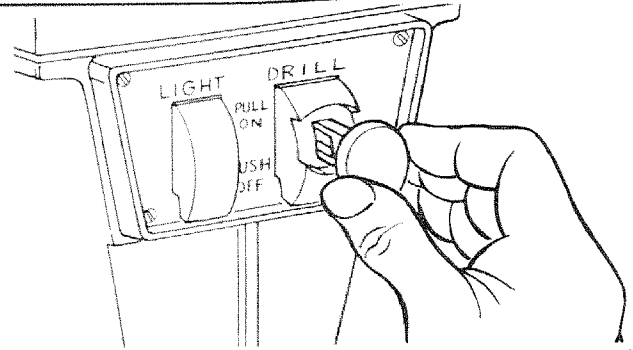

To turn drill ON ...  
Insert finger under switch lever and pull.

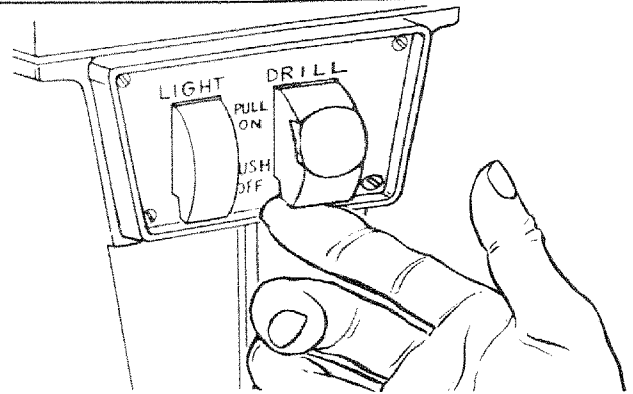

TO turn drill OFF ... Push lever in.

In an emergency; ... the drill bit BINDS ... STALLS ... STOPS ... or tends to tear the workpiece loose ... you can QUICKLY turn the drill OFF by hitting the switch with the palm of your hand.

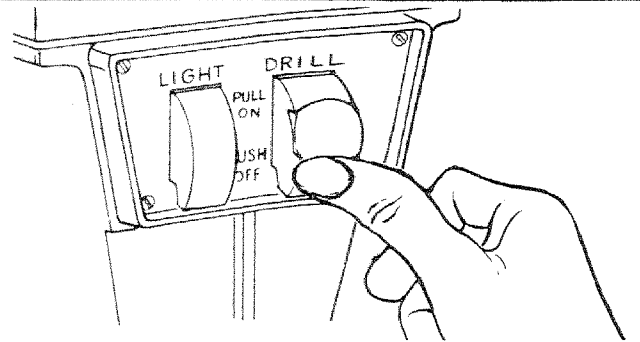

TO lock switch in OFF position ... hold switch IN with one hand ... REMOVE key with other hand.

**WARNING: FOR YOUR OWN SAFETY, ALWAYS LOCK THE SWITCH “OFF” WHEN DRILL PRESS IS NOT IN USE ... REMOVE KEY AND KEEP IT IN A SAFE PLACE ... ALSO ... IN THE EVENT OF A POWER FAILURE (ALL OF YOUR LIGHTS GO OUT) TURN SWITCH OFF ... LOCK IT AND REMOVE THE KEY. THIS WILL PREVENT THE DRILL PRESS FROM STARTING UP AGAIN WHEN THE POWER COMES BACK ON.**

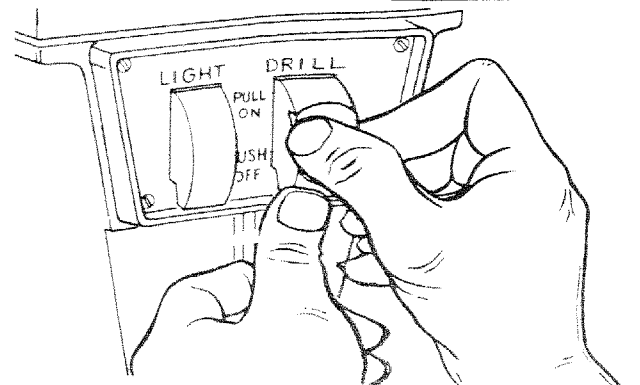

# basic drill press operation

We recommend the following instructions for operating your drill press so that you get the best results and to minimize the likelihood of personal injury.

## WARNING: FOR YOUR OWN SAFETY, ALWAYS OBSERVE THE FOLLOWING SAFETY PRECAUTIONS.

1. Check spindle speed
2. Before operating, turn the switch "on" then "off" to make sure that the cutting tool is centered in the chuck

properly and that the cutting tool is not causing excessive vibration.

3. Never perform any operation freehand (hand-holding workpiece rather than supporting it on table) except when wire brushing or polishing.
4. Keep your hands clear of the cutting tool (drill, shaper cutter or router bit).
5. Make sure quill is locked securely when shaping, routing, dovetailing, wirebrushing, polishing sanding or surface planing.

## INSTALLING DRILLS

Insert drill into chuck far enough to obtain maximum GRIPPING of the CHUCK JAWS . . . the jaws are approx. 1 in. long. When using a small drill do not insert it so far that the jaws touch the flutes (spiral grooves) of the drill.

Make sure that the drill is CENTERED in the chuck before tightening the chuck with the key.

Tighten the drill sufficiently, so that it does not SLIP while drilling.

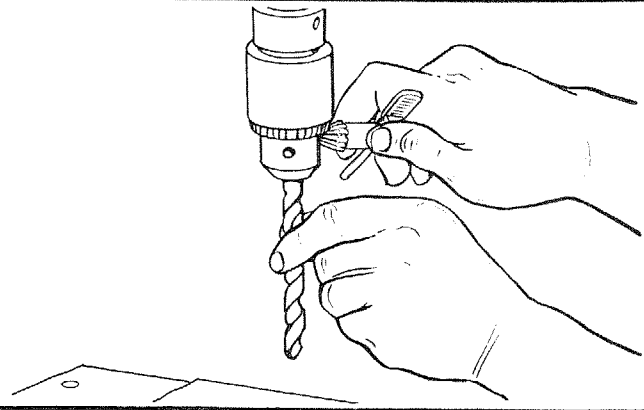

## POSITIONING TABLE AND WORKPIECE

Lock the table to the column in a position so that the tip of the drill is just a little above the top of the workpiece. It is not necessary to reposition the TABLE SUPPORT COLLAR each time you reposition the table. Always keep the collar locked about 34 in. from the floor.

Always place a piece of BACK-UP MATERIAL (wood, plywood . . .) on the table underneath the workpiece. This will prevent "splintering" or making a heavy burr on the underside of the workpiece as the drill breaks through.

Position workpiece to butt against the column whenever possible — if it is too short, clamp solidly to the Table — this is to prevent the drill bit from grabbing the work from your hands, which could result in personal injury. A drill press vise must be fastened to the table.

**CAUTION:** To prevent the workpiece or the back-up material from being torn from your hand while drilling, position them against the left side of the column. Failure to do this could result in personal injury.

**CAUTION:** If the workpiece or the back-up material are not long enough to reach the column, CLAMP them to the table. Failure to do this could result in personal injury.

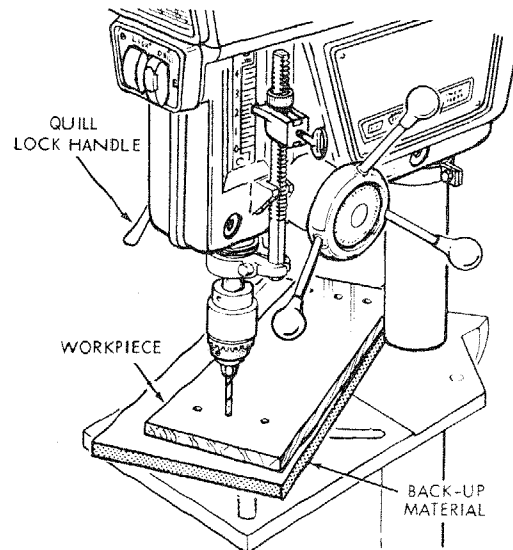

For small pieces that cannot be clamped to the table, use a drill press vise (Optional accessory). The vise must be clamped or bolted to the table.

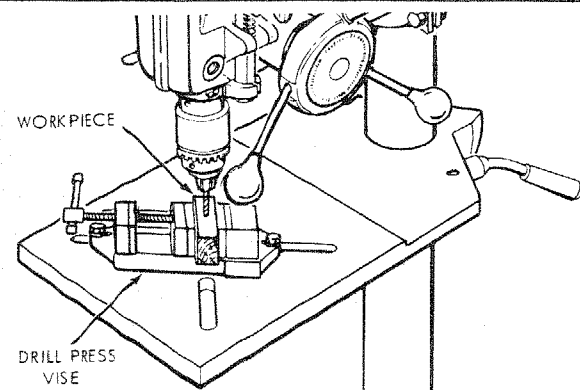



## HOLE LOCATION

Make a DENT in the workpiece where you want the hole . . . using a CENTER PUNCH or a SHARP NAIL.

Before turning the switch ON, bring the drill down to the workpiece lining it up with the hole location.

## FEEDING

Pull down on the feed handles with only enough effort to

allow the drill to cut.

Feeding TOO SLOWLY might cause the drill to burn . . . Feeding TOO RAPIDLY might stop the motor . . . cause the belt or drill to SLIP . . . tear the workpiece LOOSE from your hand or BREAK the drill bit.

When drilling metal use Sears Thread-cutting oil

# adjustments

**WARNING: FOR YOUR OWN SAFETY TURN SWITCH "OFF" AND REMOVE PLUG FROM POWER SOURCE OUTLET BEFORE MAKING ANY ADJUSTMENTS.**

## DEPTH SCALE

When the quill is in the UPPERMOST position, the top SURFACE OF THE FEED STOP POINTER should be in line with "0" graduation on the DEPTH SCALE.

If it is not . . . LOOSEN both mounting screws and reposition the scale.

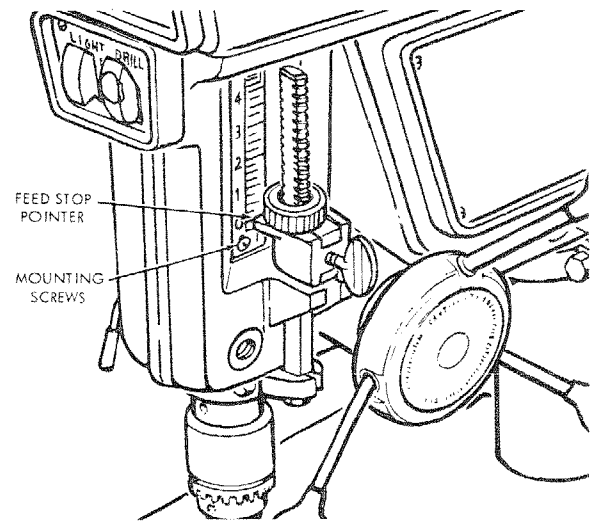

## QUILL RETURN SPRING

If the quill does not return to its UPPERMOST position when the quill lock is UNLOCKED . . . or if the return action is SLUGGISH . . . the SPRING TENSION must be increased.

1. Move DEPTH POINTER to uppermost position and lock it in place.
2. Lock the quill in the uppermost position.
3. GRASP the HUB . . . pull it straight out until it is free to turn.
4. Rotate hub COUNTERCLOCKWISE about 1/4 turn and PUSH it back in place. This will WIND UP the spring.
5. Unlock quill . . . check tension . . . if more is required, repeat steps 2, 3, 4, and 5.

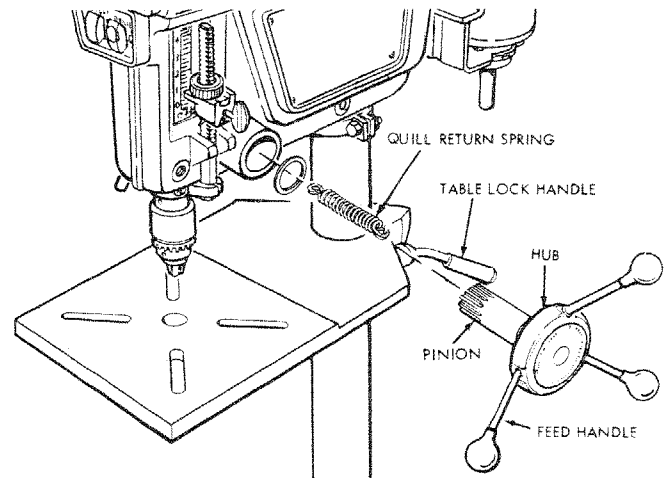

## TABLE AND HEAD LOCK HANDLES

The lock handles can be adjusted to make them more convenient to operate.

1. Make sure the support collar is locked in position below the table or the head.
2. Unscrew the lock handle and push the barrel lock out of the hole.
3. Rotate the barrel lock 180°, replace it in the hole and screw in the handle.

**NOTE:** The HEADLOCK HANDLE is located on the LEFT side of the head.

## BELT TENSION

Refer to section "Getting To Know Your Drill Press" . . . BELT TENSIONING ROD.

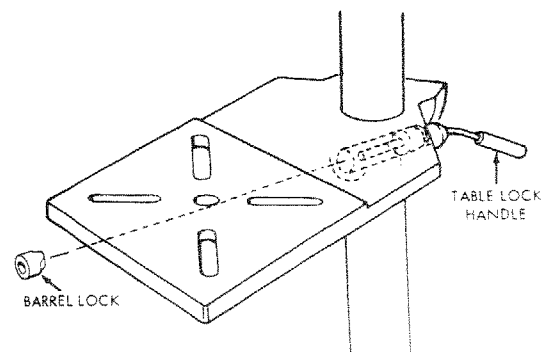

# maintenance

**WARNING: FOR YOUR OWN SAFETY, TURN SWITCH "OFF" AND REMOVE PLUG FROM POWER SOURCE OUTLET BEFORE MAINTAINING OR LUBRICATING YOUR DRILL PRESS.**

Frequently blow out any dust that may accumulate inside the motor.

A coat of automobile-type wax applied to the table and column will help to keep the surfaces clean.

If the power cord is worn or cut, or damaged in any way, have it replaced immediately.

For motor maintenance, follow instructions furnished with motor.

---

## Lubrication

All of the BALL BEARINGS are packed with grease at the factory. They require no further lubrication.

Periodically lubricate the SPLINES (grooves) in the spindle and the RACK (teeth on the quill).

USE Sears Gear Case Lubricant.

1. Lower quill and spindle all the way down . . . LOCK the quill.
2. Use a small stick of wood and apply lubricant around the inside of the hole in the spindle pulley.
3. Apply lubricant to RACK (teeth) on quill extending below drill press head.

For motors lubrication, follow instructions furnished with motor.

---

## recommended accessories

Drills, Shaper Cutters, Router Bits	See Catalog
Rotary Planer	9-2745
Mortising Chisel Housing	9-2465
Hollow Chisels and Mortising Bits	See Catalog
Dovetailing Attachment	9-2462
Shaper Fence Attachment	9-2487
Hold-Down and Guide	9-2457
Drill Press Vises	See Catalog
Rotary Table	9-2495
Tilt Table	9-2439
Collet Chuck	9-24672

Shaper Cutter Adapter	9-24832
Sanding Drum	9-2497 — 9-2498
Hole Saws up to 2½ in. dia.	See Catalog
Wire Wheels up to 4 in. dia. max.	See Catalog
Buffing Wheels up to 4 in. dia. max.	See Catalog
Polishing Wheel, 1½" x 1 In.	9-64991
Column Collar	9-2438
Power Tool Know-how Handbooks	
Radial Saw	9-2917
Table Saw	9-2918

The recommended accessories listed here are current and were available at the time this manual was printed.

# trouble shooting

**WARNING: FOR YOUR OWN SAFETY, TURN SWITCH "OFF" AND ALWAYS REMOVE PLUG FROM POWER SOURCE OUTLET BEFORE TROUBLE SHOOTING.**

TROUBLE	PROBABLE CAUSE	REMEDY
<b>Noisy Operation</b>	<ol style="list-style-type: none"> <li>1. Incorrect belt tension</li> <li>2. Dry Spindle</li> <li>3. Loose spindle pulley or motor pulley.</li> </ol>	<ol style="list-style-type: none"> <li>1. Adjust tension. See section "Getting To Know Your Drill Press" . . . BELT TENSIONING ROD.</li> <li>2. Lubricate spindle. See "Lubrication" section.</li> <li>3. Tighten setscrews in pulleys.</li> </ol>
<b>Drill Burns.</b>	<ol style="list-style-type: none"> <li>1. Incorrect speed</li> <li>2. Chips not coming out of hole.</li> <li>3. Dull Drill</li> <li>4. Feeding too slow.</li> <li>5. Not lubricated.</li> <li>6. Drill running backwards.</li> </ol>	<ol style="list-style-type: none"> <li>1. Change speed. See section "Getting To Know Your Drill Press" . . . DRILLING SPEED.</li> <li>2. Retract drill frequently to clear chips.</li> <li>3. Reshaper drill.</li> <li>4. Feed fast enough . . . allow drill to cut.</li> <li>5. Lubricate drill. See "Basic Drill Press Operation" section.</li> <li>6. Check motor rotation. See "Motor Specifications and Electrical Requirements" section.</li> </ol>
<b>Drill leads off . . . hole not round.</b>	<ol style="list-style-type: none"> <li>1. Hard grain in wood or lengths of cutting lips and/or angles not equal.</li> </ol>	<ol style="list-style-type: none"> <li>1. Resharpen drill correctly.</li> </ol>
<b>Wood splinters on underside.</b>	<ol style="list-style-type: none"> <li>1. No "back-up material" under workpiece.</li> </ol>	<ol style="list-style-type: none"> <li>1. Use "back-up material" . . . See Basic Drill Press Operation" section.</li> </ol>
<b>Workpiece torn loose from hand.</b>	<ol style="list-style-type: none"> <li>1. Not supported or clamped properly.</li> </ol>	<ol style="list-style-type: none"> <li>1. Support workpiece or clamp it . . . See "Basic Drill Press Operation" section.</li> </ol>
<b>Drill Binds in workpiece.</b>	<ol style="list-style-type: none"> <li>1. Workpiece pinching drill or excessive feed pressure.</li> <li>2. Improper belt tension.</li> </ol>	<ol style="list-style-type: none"> <li>1. Support workpiece or clamp it . . . See "Basic Drill Press Operation" section.</li> <li>2. Adjust tension . . . See section "Getting to Know Your Drill Press" . . . BELT TENSION ROD.</li> </ol>
<b>Excessive drill runout or wobble.</b>	<ol style="list-style-type: none"> <li>1. Bent drill.</li> <li>2. Worn spindle bearings.</li> <li>3. Drill not properly installed in chuck.</li> <li>4. Chuck not properly installed.</li> </ol>	<ol style="list-style-type: none"> <li>1. Use a straight drill.</li> <li>2. Replace bearings.</li> <li>3. Install drill properly . . . See "Basic Drill Press Operation" section.</li> <li>4. Install chuck properly . . . refer to "Unpacking and Assembly Instructions" . . . INSTALLING THE CHUCK.</li> </ol>

PARTS LIST FOR CRAFTSMAN DRILL PRESS MODEL NO. 113.21371 & 113.213710

repair parts

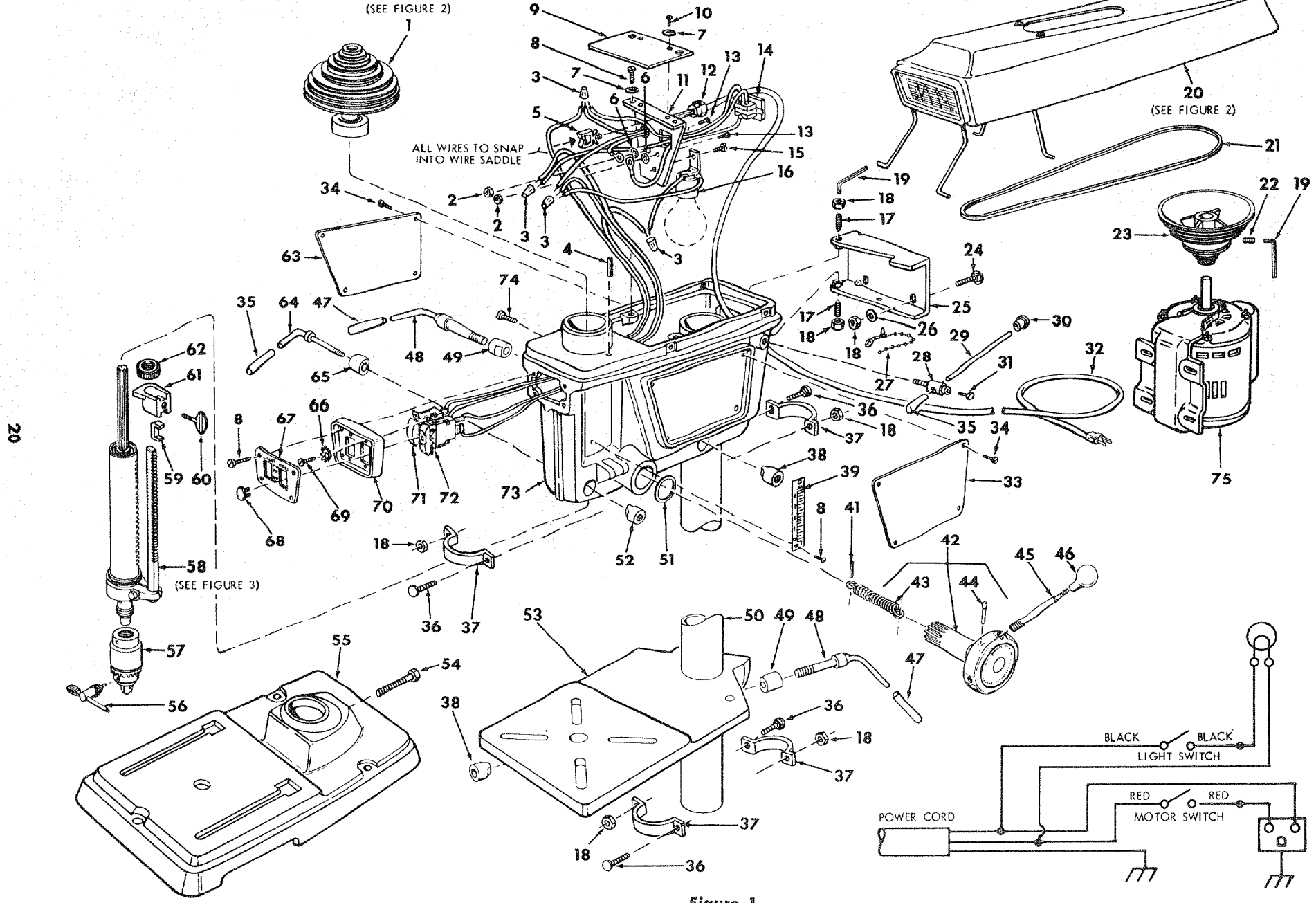

Figure 1

20

PARTS LIST FOR CRAFTSMAN DRILL PRESS MODEL NO. 113.21371 & 113.213710

Always order by Part Number — not by Key Number

FIGURE 1 PARTS LIST

Key No.	Part No.	Description
1	71097	Pulley Assembly (See Figure 2)
2	STD 541110	*Nut, Hex 10-32
3	71046	Connector, Wire 14-18
4	STD 571812	*Pin, Roll 3/16
5	71163	Saddle, Wire
6	STD 551210	*Lockwasher, Internal No. 10
7	STD 551208	Lockwasher, Int. No. 8
8	169689	*Screw, Type 23 Pan Hd. 6-32 x 5/8
9	71092	Plate, Rear Cover
10	STD 610805	*Screw, Type A Pan Sl. No. 8 x 1/2
11	71170	Bracket
12	37818	Relief, Strain
13	STD 601103	*Screw, Type 23 Pan Sl. 10-32 x 3/8
14	71056	Outlet
15	STD 610802	*Screw, Type A Pan Sl.No. 8 x 1/4
16	71088	Socket, Bulb
17	139377	*Screw, Set Cone Pt., 5/16-18 x 1-1/4
18	STD 541231	*Nut, Hex 5/16-18
19	37837	Wrench, Hex "L" 5/32
20		Guard Assembly (See Figure 2)
21	71138	Belt, V
22	9411963	*Screw, Set Soc.Cup Pt.5/16-18 x 1/2
23	71065	Pulley, Motor
24	STD 532507	*Bolt, Carriage, 5/16-18 x 3/4
25	71164	Mount, Motor
26	STD 551031	*Washer, 11/32
27	71165	Tie, Wire
28	71151	Clamp, Adjusting Rod
29	71153	Rod, Adjusting
30	71152	Tip, Adjusting Rod
31	60226	Screw, Adjusting Rod
32	71166	Cord with Plug
33	71167	Panel, R.H. Trim
34	145372	*Screw, Drive Rd.Hd.No. 4 x 1/4
35	60307	Grip
36	STD 533115	*Bolt, Carriage 5/16-18 x 1-1/2
37	71050	Collar
38	38626	Lock, Barrel

Key No.	Part No.	Description
39	71098	Scale, Depth
41	60193	*Pin, Roll 3/16
42	71074	Hub Assembly (Includes Key Nos. 43 & 44)
43	38989	Spring
44	27617	Pin
45	71139	Rod
46	38546	Knob
47	60260	Grip
48	60265	Handle, Lock
49	38627	Lock, Barrel
50	71136	Tube, Column
51	38452	Washer, Fiber
52	38631	Lock, Barrel
53	71168	Table
54	100163	Bolt, Hex Hd. 1/2-13 x 2-1/2
55	71101	Base
56	71178	Key, Drill Chuck
57	38623	Chuck, Drill
58	71075	Spindle Ass'y., Stop (See Figure 3)
59	71149	Shoe, Depth Gage
60	60191	Screw, Thumb
61	71140	Pointer, Depth Gage
62	71082	Nut, Stop
63	71169	Panel, L.H. Trim
64	71161	Handle
65	38632	Lock, Barrel
66	318595	Lockwasher, Int. C'Sink No. 6
67	71146	Cover, Switch Plate
68	60256	Key, Switch
69	133423	*Screw, Mach.Flat Hd.6-32 x 3/8
70	71086	Plate, Switch Mounting
71	71144	Switch
72	71145	Switch
73	71099	Head, Drill Press (Includes Key No. 74)
74	132124	*Screw Fil.Hd. 10-32 x 3/4
75	70047	†Motor, 1/2 H.P. 1725 RPM
	71189	Owners Manual (Not Illustrated)
	71175	Bag Assy., Loose Parts (Not Illustrated)

\*Standard Hardware Item — May be Purchased Locally

† Stock Item — May be secured through the hardware dept. of most Sears Retail or Catalog Outlets.

PARTS LIST FOR CRAFTSMAN DRILL PRESS  
MODEL NO. 113.21371 & 113.213710

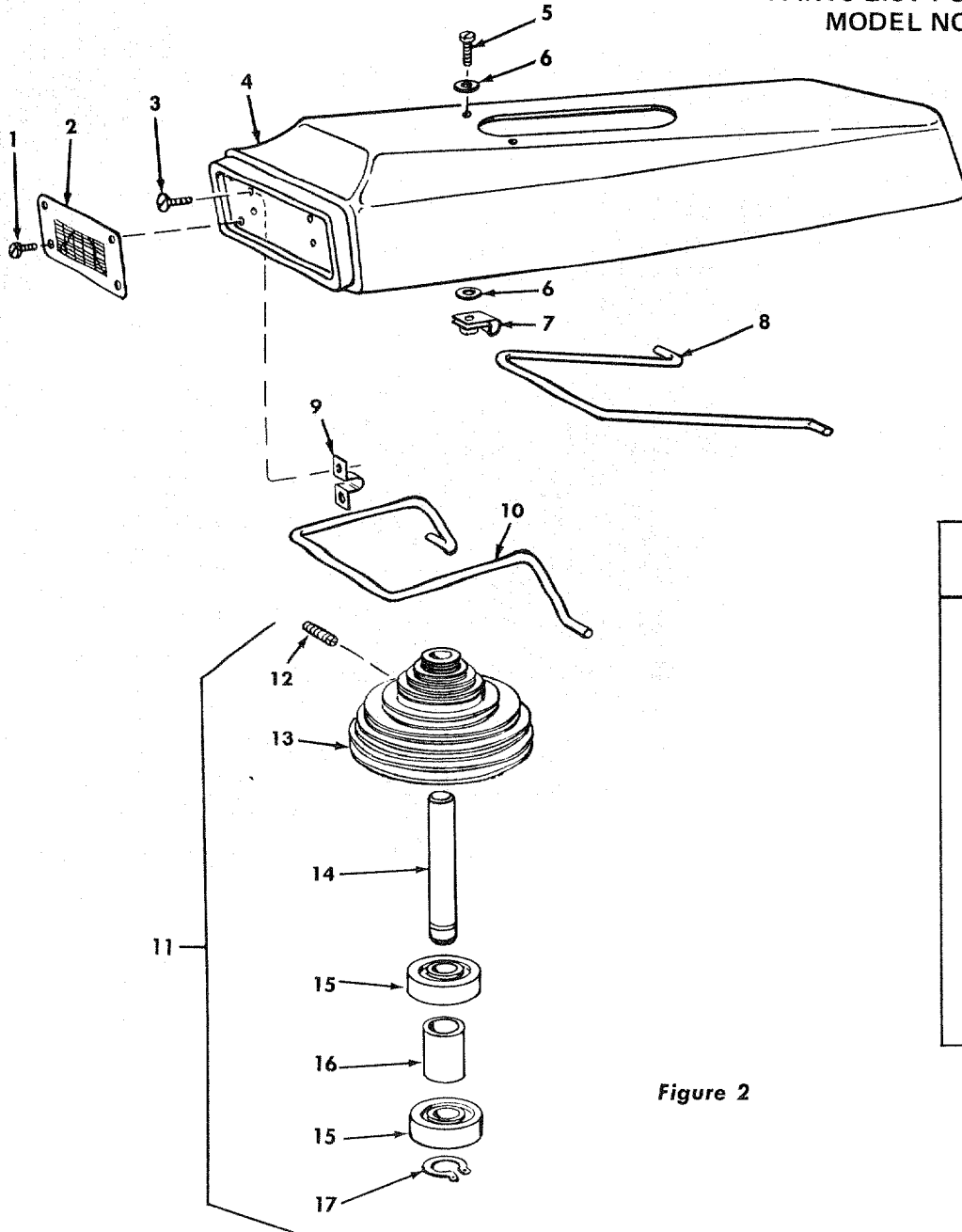

FIGURE 2 PARTS LIST

Key No.	Part No.	Description
1	60049	*Screw, Pan Hd., 4-40 x 3/16
2	71173	Panel, Front Guard
3	144987	*Screw, Type B, Flat Hd., No. 10 x 1/2
4	71069	Guard
5	STD 610807	*Screw, Type B, Pan Hd., No. 8 x 3/4
6	60158	*Washer, 13/64 x 9/16 x 3/64
7	71071	Clamp
8	71070	Link, Rear
9	71162	Clamp
10	71072	Link, Front
11	71097	Pulley Assembly, Spindle
12	60192	Screw, Nylok Set, 5/16-18 x 1/2
13	71089	Pulley, Spindle
14	71090	Insert, Pulley
15	STD 315253	Bearing, Ball
16	71091	Spacer
17	18414	Ring, Retaining, 15/16

Figure 2

\*Standard Hardware Item - May be Purchased Locally.

PARTS LIST FOR CRAFTSMAN DRILL PRESS  
MODEL NO. 113.21371 & 113.213710

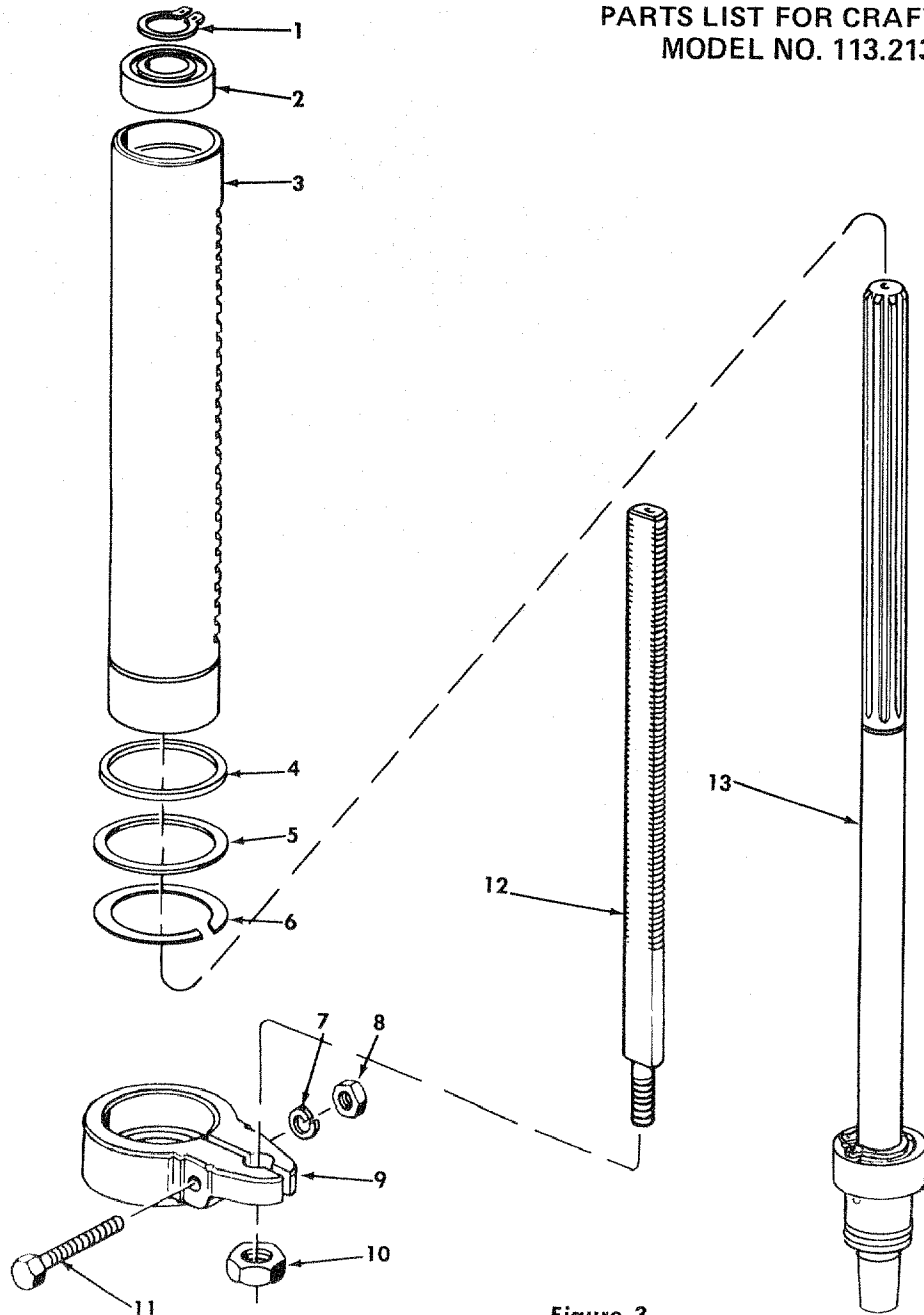

FIGURE 3 – 71075 SPINDLE ASSEMBLY, STOP

Key No.	Part No.	Description
—	71075	Spindle Assembly, Stop
1	37158	Ring, Retaining, 5/8
2	3509	Bearing, Ball
3	71147	Tube, Quill
4	27813	Gasket, Quill
5	60176	Washer, Quill
6	27812	Ring, Retaining
7	STD 551125	*Lockwasher, 1/4
8	STD 541025	*Nut, Hex, 1/4-20
9	38422	Collar, Feed Stop
10	STD 541237	*Nut, Hex.Jam, 3/8-16
11	STD 522512	*Screw, Mach., Hex.Hd., 1/4-20 x 1-1/4
12	71078	Rod, Depth Stop
13	71077	Spindle Assembly

\*Standard Hardware Item – May be Purchased Locally.

Figure 3

**Sears**

*owners  
manual*

**SERVICE**

**MODEL NO.  
113.21371**

DRILL PRESS ONLY

**113.213710**

DRILL PRESS WITH  
1/2 HP MOTOR

**HOW TO ORDER  
REPAIR PARTS**

## 15-1/2 INCH DRILL PRESS

Now that you have purchased your 15-1/2 inch drill press should a need ever exist for repair parts or service, simply contact any Sears Service Center and most Sears, Roebuck and Co. stores. Be sure to provide all pertinent facts when you call or visit.

The model number of your 15-1/2 inch drill press will be found on a plate attached to the rear of the head.

WHEN ORDERING REPAIR PARTS, ALWAYS GIVE THE FOLLOWING INFORMATION:

PART NUMBER	PART DESCRIPTION
MODEL NUMBER	NAME OF ITEM
113.21371 —	15-1/2 INCH DRILL PRESS
113.213710	

All parts listed may be ordered from any Sears Service Center and most Sears stores. If the parts you need are not stocked locally, your order will be electronically transmitted to a Sears Repair Parts Distribution Center for handling.

**Sold by SEARS, ROEBUCK AND CO., Chicago, IL. 60684 U.S.A.**