

# Exploded View of Wash System

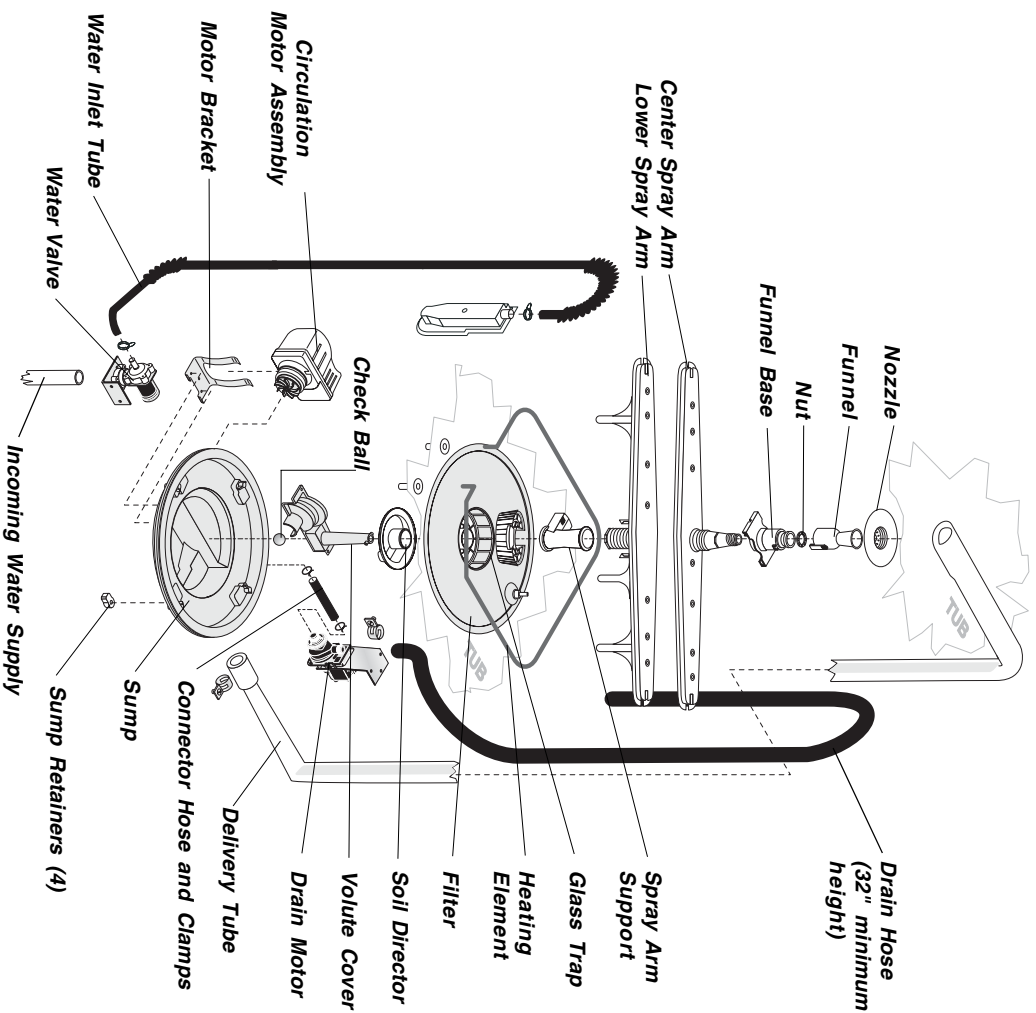

## Pump Assembly

The pump assembly is driven by a synchronous motor. Rotation is in the counterclockwise direction at 3600 RPM. The motor drives a pump which supplies 100 percent filtered water at a rate of approximately 12 GPM to one spray arm at a time. The spray arm's operation is alternated by small "pauses" of the motor during the wash cycle.

Draining is accomplished by using a small separate synchronous drain pump mounted to the side of the sump. The drain pump is connected to the main pump by a small rubber hose. The drain check valve is located at the discharge end of the drain pump. The drain hose

is attached by a worm gear clamp to the discharge end of the drain pump.  
The drain hose must have a loop at a **minimum height of 32 inches** in order to insure proper drainage.

The main pump can easily be removed by disconnecting the upper spray arm supply tube hose, the drain pump connector hose, the wiring harness connections made at the circulation motor, the water heat thermostat located on the bottom of the pump and rotating the four sump retainers toward the middle of the sump.

## 900 Watt Heater

Refer to the cycle chart on the reverse side to determine when the heater is on during the wash cycle. The heater cycles **ON** and **OFF** for brief periods during the drying cycle.

Voltage checks of the heater should be made in the dry portion of the service test mode.

## Standard Dry Air Flow

When the control advances to the "dry" portion of the cycle, a linear actuator retracts a valve, which opens a vent path through the console into the kitchen. The heated, moist air leaving the dishwasher through the console vent causes drier air to be drawn into the unit by way of intake

vents located at the bottom of the door. The water on the dishes is evaporated into drier air and the venting process continues. The heating element is turned **ON** and **OFF** during the entire drying cycle.

## Detergent and Rinse Aid Dispenser

The detergent and rinse aid dispenser is a one piece component consisting of a molded detergent cup and a built-in rinse aid dispenser. The detergent cup has a spring loaded cover and the rinse aid dispenser has a removable cover.

Liquid rinse aid is added to the dispenser up to the fill line indicator. The amount of rinse aid released can be adjusted by turning the arrow indicator from one, being the least amount, to four, being the greatest amount.

### To replace dispenser:

- shut off electricity to dishwasher,
- remove outer door panel assembly,
- disconnect wiring to the actuator,
- remove the six screws,
- remove the dispenser,
- replace and reinstall screws,
- rewire actuator.

## Tub and Door Seal

The door seal is pressed into the tub channel for an interference fit. Center the gasket (marked on back) at the tub top center and press in place

without stretching or bunching. The gasket takes a short turn at the bottom of the tub channel before ending at the channel end wall.

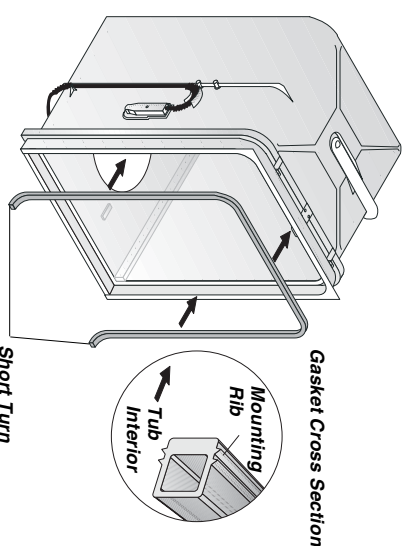

## Product Specifications

### Electrical

Rating ..... 120 Volts, 60Hz  
Separate Circuit: 15 amp min. - 20 amp max.  
Motor (Amps) ..... 1.1  
Heater Wattage ..... 900  
Total Amps (load rated) ..... 10.0  
TempAssure ..... 140°F ±5°F  
(60°C±3°C) [with outer door in place]  
TempBoost ..... 145°F ±5°F (63°C ±3°C)  
Heated Wash/Heated Rinse  
Sanitize ..... 150°F ±5°F (66°C ±3°C)  
Hi-Limit Thermostat ..... 200°F (93°C)

### Water Supply

Suggested minimum incoming water  
Temperature ..... 120°F (49°C)  
Pressure (PSI) min./max. .... 20/120  
Connection (NPT) ..... 3/8"  
Consumption (Normal Cycle) .....  
..... 4.9 - 9.7 U.S. gal., 18.5 - 36.7 liters  
Water valve flow rate (U.S. GPM) ..... .83  
Water recirculation rate (U.S. GPM) .....  
..... approx. 12  
Water fill time ..... 87 sec.

# Trouble Shooting Tips

## ⚠ WARNING

Personal Injury Hazard

Always disconnect the dishwasher from the electrical power source before adjusting or replacing components.

Symptom	Check the Following	Remedy
Dishwasher will not operate when turned on.	<ol style="list-style-type: none"> <li>1. Fuse (blown or tripped).</li> <li>2. 120 VAC supply wiring connection faulty.</li> <li>3. Electronic control board defective.</li> <li>4. No 12 VAC power to control.</li> <li>5. Motor (inoperative).</li> <li>6. Door switch (open contacts).</li> <li>7. Door latch not making contact with door switch.</li> <li>8. Touch pad circuit defective.</li> <li>9. No indicator lamps illuminate when START or OPTIONS are pressed.</li> </ol>	<ol style="list-style-type: none"> <li>1. Replace fuse or reset breaker.</li> <li>2. Repair or replace wire fasteners at dishwasher junction box.</li> <li>3. Replace control board.</li> <li>4. Replace control board.</li> <li>5. Replace motor/impeller assembly.</li> <li>6. Replace latch assembly.</li> <li>7. Replace latch assembly.</li> <li>8. Replace console assembly.</li> <li>9. Replace console assembly.</li> </ol>
Dishwasher runs but will not start or run.	<ol style="list-style-type: none"> <li>1. Motor (bad bearings).</li> <li>2. Motor stuck due to prolonged non-use.</li> </ol>	<ol style="list-style-type: none"> <li>1. Replace motor assembly.</li> <li>2. Rotate motor/impeller.</li> </ol>
Motor trips out on internal thermal overload protector.	<ol style="list-style-type: none"> <li>1. Improper voltage.</li> <li>2. Motor windings shorted.</li> <li>3. Glass or foreign items in pump.</li> </ol>	<ol style="list-style-type: none"> <li>1. Check voltage.</li> <li>2. Replace motor/impeller assembly.</li> <li>3. Clean and clear blockage.</li> </ol>
Dishwasher runs but will not heat.	<ol style="list-style-type: none"> <li>1. Heater element (open).</li> <li>2. Electronic control board defective.</li> <li>3. Wiring or terminal defective.</li> <li>4. Hi-Limit thermostat defective.</li> </ol>	<ol style="list-style-type: none"> <li>1. Replace heater element.</li> <li>2. Replace control board.</li> <li>3. Repair or replace.</li> <li>4. Replace thermostat.</li> </ol>
Detergent cover will not latch or open.	<ol style="list-style-type: none"> <li>1. Latch mechanism defective.</li> <li>2. Electronic control board defective.</li> <li>3. Wiring or terminal defective.</li> <li>4. Broken spring(s).</li> <li>5. Defective actuator.</li> </ol>	<ol style="list-style-type: none"> <li>1. Replace dispenser.</li> <li>2. Replace control board.</li> <li>3. Repair or replace.</li> <li>4. Replace dispenser.</li> <li>5. Replace dispenser.</li> </ol>
Dishwasher will not pump out.	<ol style="list-style-type: none"> <li>1. Drain restricted.</li> <li>2. Electronic control board defective.</li> <li>3. Defective drain pump.</li> <li>4. Blocked impeller.</li> <li>5. Open windings.</li> <li>6. Wiring or terminal defective.</li> </ol>	<ol style="list-style-type: none"> <li>1. Clear restrictions.</li> <li>2. Replace control board.</li> <li>3. Replace pump.</li> <li>4. Check for blockage, clear.</li> <li>5. Replace pump assembly.</li> <li>6. Repair or replace.</li> </ol>
Dishwasher will not fill with water.	<ol style="list-style-type: none"> <li>1. Water supply turned off.</li> <li>2. Defective water inlet fill valve.</li> <li>3. Check fill valve screen for obstructions.</li> <li>4. Defective float switch.</li> <li>5. Electronic control board defective.</li> <li>6. Wiring or terminal defective.</li> <li>7. Float stuck in "UP" position.</li> </ol>	<ol style="list-style-type: none"> <li>1. Turn water supply on.</li> <li>2. Replace water inlet fill valve.</li> <li>3. Disassemble and clean screen.</li> <li>4. Repair or replace.</li> <li>5. Replace control board.</li> <li>6. Repair or replace.</li> <li>7. Clean float.</li> </ol>
Dishwasher water siphons out.	<ol style="list-style-type: none"> <li>1. Drain hose (high) loop too low.</li> <li>2. Drain line connected to a floor drain not vented.</li> </ol>	<ol style="list-style-type: none"> <li>1. Repair to proper <b>32-inch minimum height.</b></li> <li>2. Install air gap at counter top.</li> </ol>
Detergent left in dispenser.	<ol style="list-style-type: none"> <li>1. Detergent allowed to stand too long in dispenser.</li> <li>2. Dispenser wet when detergent was added.</li> <li>3. Detergent cover held closed or blocked by large dishes.</li> <li>4. Improper incoming water temperature to properly dissolve detergent.</li> <li>5. See "Detergent cover will not open."</li> </ol>	<ol style="list-style-type: none"> <li>1. Instruct customer/user.</li> <li>2. Instruct customer/user.</li> <li>3. Instruct customer/user on proper loading of dishes.</li> <li>4. Incoming water temperature of 120°F is required to properly dissolve dishwashing detergents.</li> </ol>

# SERVICE DATA SHEET

P/N: 154476701

*Frigidaire*  
Electronic Series

### Color Code

BK.....Black  
BU.....Blue  
PK.....Pink  
R.....Red  
R-BK.....Red/Black  
R-Y.....Red/Yellow  
VIO.....Violet  
W.....White

### Operation

To start . . . . . Close and latch door. Press START/CANCEL pad.  
To delay start . . . . . Close and latch door. Press DELAY START pad to select desired delay time.  
To select a new cycle or option . . . . . Press desired cycle and/or option pad. The indicator lights will change. Press START/CANCEL within 15 seconds to begin cycle.  
To cancel cycle . . . . . Press START/CANCEL. Dishwasher will drain for 90 seconds, then shut off.  
For controls lock . . . . . Press and hold the RINSE HOLD or NO HEAT DRY pad for 3 seconds, then shut off. To unlock, press and hold the RINSE HOLD or NO HEAT DRY pad for 3 seconds.

### Water/Service Test

The water/service test is a special function initiated from the power failure mode or idle mode.

While in power failure mode - simultaneously press the NO HEAT DRY and START/CANCEL pads for 1 1/2 seconds.

The dishwasher will then step through the test cycle per the chart. Pushing the START/CANCEL pad will advance the dishwasher to the next step.

While in idle mode - simultaneously press HI-TEMP WASH & START/CANCEL pads for 1 1/2 seconds.

STEP	TOTAL TIME (SEC)	WATER VALVE	CIRCULATION MOTOR	DRAIN MOTOR	HEATER	DISPENSER	VENT	SENSING LED	WASHING LED	SANITIZED LED	DRYING LED	CLEAN LED
1 FILL/DISPENSER	60	1	0	0	1	0	1	1	1	0	0	0
2 FILL	27	1	0	0	0	0	0	1	1	0	0	0
3 WASH/HEAT	45	0	1	0	1	0	1	1	1	0	0	0
4 PAUSE	0:8	0	0	0	1	0	0	1	1	0	0	0
5 WASH/HEAT	75	0	1	0	1	0	0	0	0	0	0	0
6 WASH/HEAT/DSP	60	0	1	0	1	1	0	0	0	0	0	0
7 DRAIN	90	0	0	1	0	0	0	0	0	0	0	0
8 DRY	90	0	0	1	X	0	1	0	0	0	1	0
TOTAL	488							0	0	1	0	1

CLEAN LED stays on until door is opened or cycle is started. X - denotes selectable option.

### Display Codes (Readout)

LO.....Low liquid in the rinse aid dispenser  
PF.....A power failure has occurred  
HO.....Water heating delay  
CL.....Close and latch the door  
'01-24'.....Hour(s) delay before start (Some models)  
'01-10'.....Hour(s) delay before start (Some models)

### Display Codes (LED)

SENSING .....Turbidity sensor is checking the condition of the wash/rinse water. No sensing for LIGHT WASH (UPPER RACK), LIGHT WASH (LOWER RACK) and CHINA/CRYSTAL. WASHING .....Wash portion of cycle. SANITIZED .....The SANITIZED criteria has been met. Indicator light will switch off when door is opened. DRYING .....Drying portion of cycle. CLEAN .....Shows completion of cycle. Indicator light will switch off when door is opened. OPTION LED's Flashing -- HI-TEMP WASH and NO HEAT DRY/POWER DRY OFF LED's flashing indicates power failure has occurred. Press START/CANCEL pad and reselect desired options and cycle. STATUS LED's that are lit when the door is opened will flash. Close door. RINSE AGENT LOW .....The liquid rinse agent is low. Light will switch off after 5 complete wash cycles or dispenser is filled. (Some models)

### Wiring Diagram

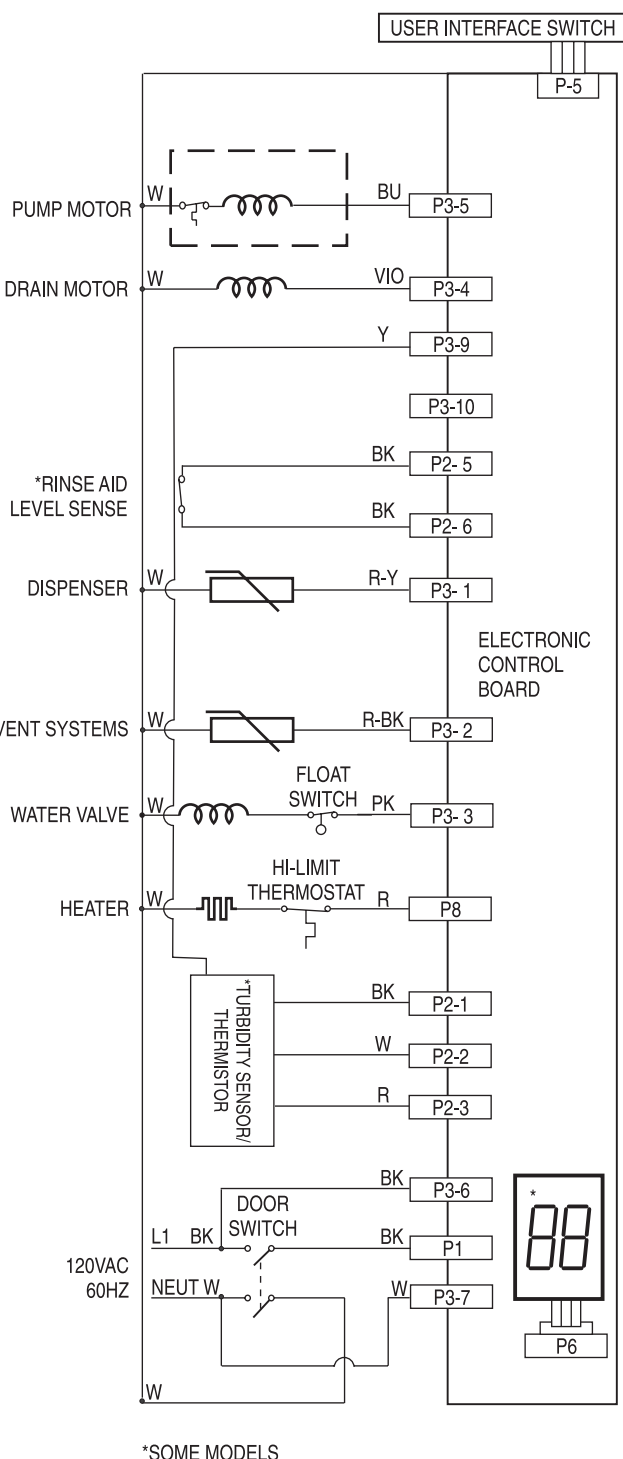

### Cycle Selection Options

CYCLES	TIME IN MINUTES		WASH 1 8 MIN.	RINSE 1 10 MIN.	RINSE 2 10 MIN.	WASH 2 21 MIN.	RINSE 3 10 MIN.	RINSE 4 10 MIN.	RINSE 5 10 MIN.	RINSE 6 12.5 MIN.	DRY (HOT OR COOL) 23.5 MIN.
	LED	CLEAN									
POTS & PANS											
NORMAL WASH											
LIGHT (BOTH)											
LIGHT (UPPER)											
LIGHT (LOWER)											
CHINA/CRYSTAL											
RINSE HOLD											
SENSING											
WASHING											
SANITIZED											
DRYING											
CLEAN											
OUTPUTS											
WATER VALVE											
DRY SYSTEM											
PUMP MOTOR											
DRAIN MOTOR											
HEATER											
DISPENSERS											
TURBIDITY SENSE											

▲WATER HEAT DELAY