

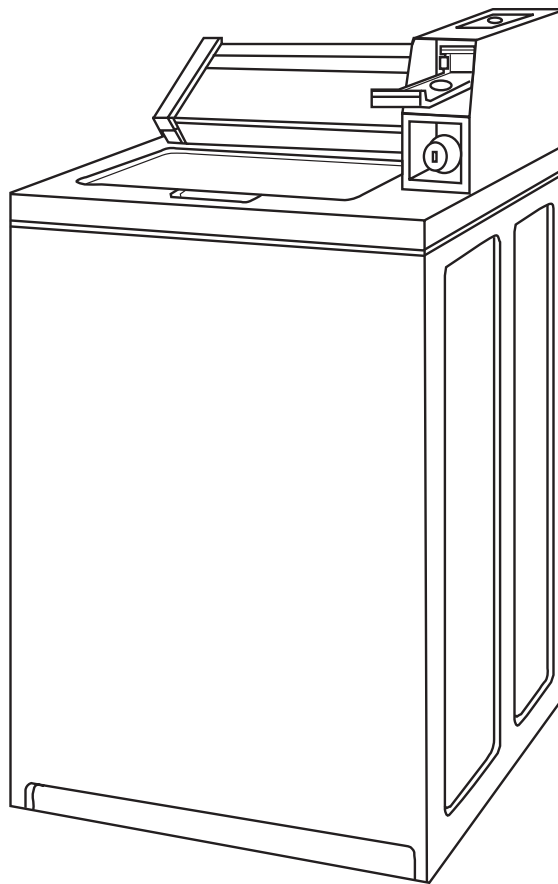

INSTALLATION INSTRUCTIONS COMMERCIAL WASHER

120-volt, 60-Hz Models



Write down the model and serial numbers before installing washer.

Both numbers are listed on the model/serial rating plate located under the lid.

Model # _____

Serial # _____

Date of Purchase _____

Table of Contents

WASHER SAFETY	2
INSTALLATION REQUIREMENTS	3
Tools and Parts	3
Location Requirements.....	3
Drain System.....	4
Electrical Requirements	5
INSTALLATION INSTRUCTIONS	6
Before You Start	6
Remove Shipping Strap	6
Connect the Hoses.....	6
Level the Washer	7
Complete Installation	8
Adjust Timer Clutch	9
Additional Features.....	10

WASHER SAFETY

Your safety and the safety of others are very important.

We have provided many important safety messages in this manual and on your appliance. Always read and obey all safety messages.



This is the safety alert symbol.

This symbol alerts you to potential hazards that can kill or hurt you and others.

All safety messages will follow the safety alert symbol and either the word "DANGER" or "WARNING."

These words mean:

⚠ DANGER

You can be killed or seriously injured if you don't immediately follow instructions.

⚠ WARNING

You can be killed or seriously injured if you don't follow instructions.

All safety messages will tell you what the potential hazard is, tell you how to reduce the chance of injury, and tell you what can happen if the instructions are not followed.

IMPORTANT SAFETY INSTRUCTIONS

WARNING: To reduce the risk of fire, electric shock, or injury to persons when using the washer, follow basic precautions, including the following:

- Read all instructions before using the washer.
- Do not wash articles that have been previously cleaned in, washed in, soaked in, or spotted with gasoline, dry-cleaning solvents, other flammable, or explosive substances as they give off vapors that could ignite or explode.
- Do not add gasoline, dry-cleaning solvents, or other flammable, or explosive substances to the wash water. These substances give off vapors that could ignite or explode.
- Under certain conditions, hydrogen gas may be produced in a hot water system that has not been used for 2 weeks or more. **HYDROGEN GAS IS EXPLOSIVE.** If the hot water system has not been used for such a period, before using the washing machine, turn on all hot water faucets and let the water flow from each for several minutes. This will release any accumulated hydrogen gas. As the gas is flammable, do not smoke or use an open flame during this time.
- Do not allow children to play on or in the washer. Close supervision of children is necessary when the washer is used near children.
- Before the washer is removed from service or discarded, remove the door or lid.
- Do not reach into the washer if the drum, tub or agitator is moving.
- Do not install or store the washer where it will be exposed to the weather.
- Do not tamper with controls.
- Do not repair or replace any part of the washer or attempt any servicing unless specifically recommended in this manual or in published user-repair instructions that you understand and have the skills to carry out.
- See "Electrical Requirements" for grounding instructions.

SAVE THESE INSTRUCTIONS

INSTALLATION REQUIREMENTS

Tools and Parts

Gather the required tools and parts before starting installation. Read and follow the instructions provided with any tools listed here.

Tools needed

- Level
- Utility knife
- Scissors
- 8" or 10" adjustable wrench
- Flat-blade screwdriver
- Pliers
- Bucket

Parts supplied

Remove parts bag from washer. Check that all parts were included.

- 1 hose clamp
- 2 inlet hoses
- 4 flat water hose washers
- 2 front-leveling legs with nuts
- 1 drain hose

Location Requirements

IMPORTANT: Do not install or store the washer where it will be exposed to the weather.

Proper installation is your responsibility.

You will need:

- A water heater set to deliver 120°F (49°C) water to the washer.
- A grounded electrical outlet located within 4 ft (1.2 m) of where the power cord is attached to the back of the washer. See "Electrical Requirements."
- Hot and cold water faucets located within 4 ft (1.2 m) of the hot and cold water fill valves, and water pressure of 10-100 psi (69-690 kPa).
- A level floor with a maximum slope of 1" (2.5 cm) under entire washer.
- A sturdy floor to support the washer weight (washer, water and load) of 315 lbs (143 kgs).
- A 12" (30 cm) minimum riser to provide an air cushion and prevent noise and damage to valves for a single washer installation.

Do not store or operate the washer in temperatures at or below 32°F (0°C). Some water can remain in the washer and can cause damage in low temperatures.

Recessed Area and Closet Installation Instructions

This washer may be installed in a recessed area or closet.

The installation spacing is in inches and is the minimum allowable. Additional spacing should be considered for ease of installation, servicing, and compliance with local codes and ordinances.

If closet door is installed, the minimum unobstructed air opening in the top and bottom is required. Louvered doors with equivalent air openings are acceptable.

Minimum Installation Clearances

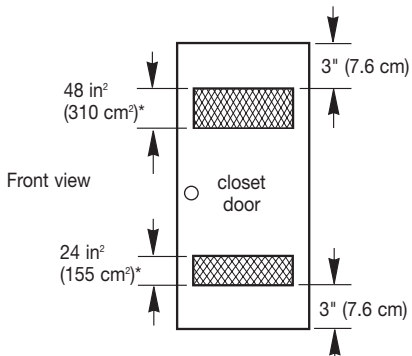
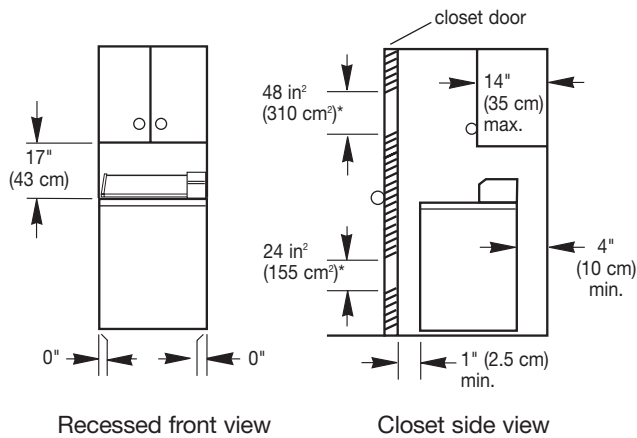

*Opening is the minimum for a closet door.
Louvered doors with equivalent air openings are acceptable.

- Additional spacing should be considered for the ease of installation and servicing.
- Additional clearances may be required for wall, door and floor moldings.
- Additional spacing of 1" (2.5 cm) on all sides of the washer is recommended to reduce noise transfer.
- Companion spacing should also be considered.

Product Dimensions

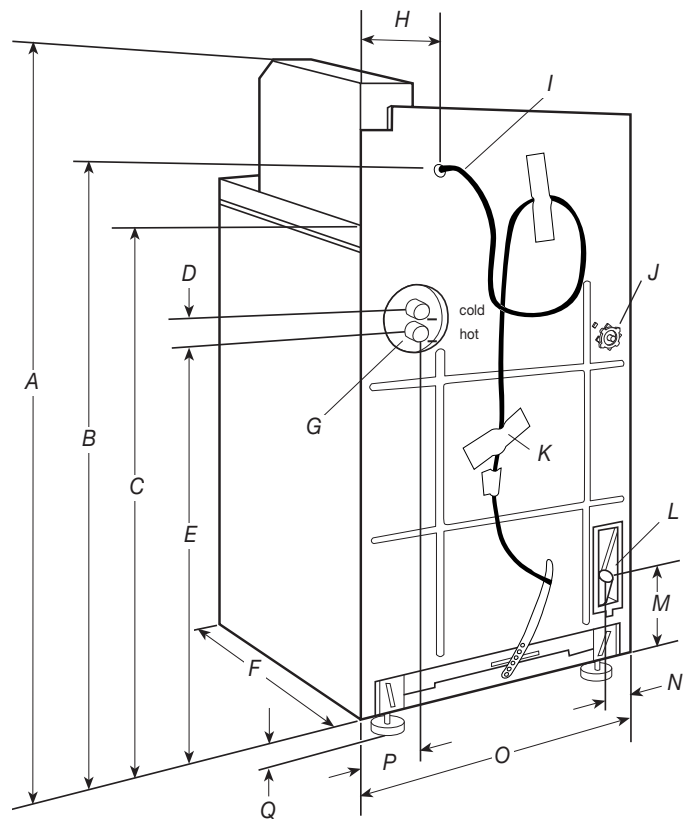

- A. 43" (109 cm)
- B. 38 1/8" (97 cm)
- C. 35" (89 cm)
- D. 1 1/2" (4 cm)
- E. 27 3/4" (70.5 cm)
- F. 25 1/2" (65 cm)
- G. Water inlets
- H. 7" (18 cm)
- I. Power supply cord
- J. Water level switch and shaft
- K. Label
- L. Drain hose connector
- M. 7" (18 cm)
- N. 5" (12.7 cm)
- O. 27" (68.5 cm)
- P. 5 1/4" (13.3 cm)
- Q. 1" (2.5 cm)

Drain System

Standpipe Drain System

The standpipe drain requires a minimum diameter standpipe of 2" (5 cm). The minimum carry-away capacity can be no less than 17 gal. (64 L) per minute.

The top of the standpipe must be at least 39" (99 cm) high and no higher than 72" (183 cm) from the bottom of the washer.

Electrical Requirements

⚠ WARNING



Electrical Shock Hazard

Plug into a grounded 3 prong outlet.

Do not remove ground prong.

Do not use an adapter.

Do not use an extension cord.

Failure to follow these instructions can result in death, fire, or electrical shock.

IMPORTANT: The washer must be electrically grounded in accordance with local codes and ordinances or, in the absence of local codes, with the National Electrical Code, ANSI/NFPA 70, latest edition.

- If codes permit and a separate ground wire is used, it is recommended that a qualified electrical installer determine that the ground path is adequate.
- Do not ground to a gas pipe.
- Do not have a fuse in the neutral or ground circuit.

A copy of the above code standards can be obtained from:

National Fire Protection Association
One Batterymarch Park, Quincy, MA 02269

- A 120-volt, 60-Hz, AC-only, 15- or 20-amp, fused electrical circuit is required. A time-delay fuse or circuit breaker is also recommended. It is recommended that a separate circuit serving only this washer be provided.
- The washer is equipped with a power supply cord having a 3 prong grounding plug.
- To minimize possible shock hazard, the cord must be plugged into a mating, 3 prong, grounded-type outlet, grounded in accordance with local codes and ordinances. If a mating outlet is not available, it is the personal responsibility and obligation of the customer to have the properly grounded outlet installed by a qualified electrician.

Recommended Ground Method

The washer, when installed, must be electrically grounded in accordance with local codes, or in the absence of local codes, with the National Electrical Code, ANSI/NFPA 70, latest edition, and all local codes and ordinances.

GROUNDING INSTRUCTIONS

For a grounded, cord-connected washer:

This washer must be grounded. In the event of a malfunction or breakdown, grounding will reduce the risk of electrical shock by providing a path of least resistance for electric current. This washer is equipped with a cord having an equipment-grounding conductor and a grounding plug. The plug must be plugged into an appropriate outlet that is properly installed and grounded in accordance with all local codes and ordinances.

WARNING: Improper connection of the equipment-grounding conductor can result in a risk of electric shock. Check with a qualified electrician or serviceman if you are in doubt as to whether the appliance is properly grounded.

Do not modify the plug provided with the appliance – if it will not fit the outlet, have a proper outlet installed by a qualified electrician.

For a permanently connected washer:

This washer must be connected to a grounded metal, permanent wiring system, or an equipment grounding conductor must be run with the circuit conductors and connected to the equipment-grounding terminal or lead on the appliance.

INSTALLATION INSTRUCTIONS

Before You Start

! WARNING

Excessive Weight Hazard

**Use two or more people to move and install washer.
Failure to do so can result in back or other injury.**

NOTE: To prevent floor damage, set the washer onto cardboard before moving across floor.

Remove Shipping Strap

1. Remove tape that covers shipping strap. Pull to completely remove the shipping strap with 2 cotter pins from the inside of the washer.

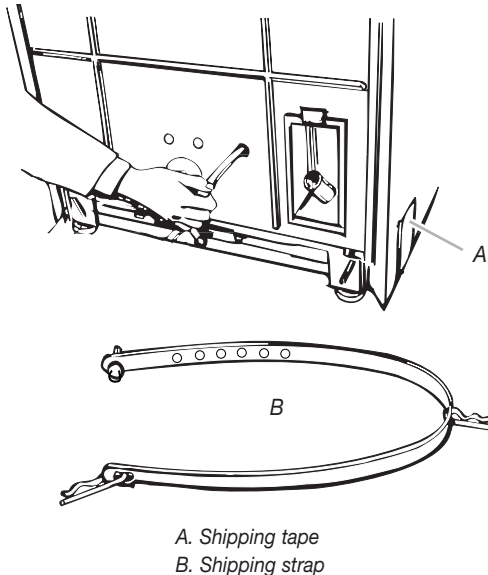

2. Pull firmly to remove the end of shipping strap from the back of the washer. The shipping strap plug must be completely removed from the washer for the self-leveling legs to be released.

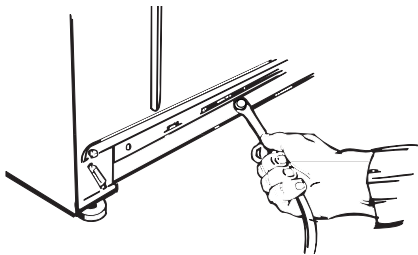

Save the shipping strap for later use.

Connect the Hoses

- Use new hoses and washers that came with your washer.
- Replace inlet hoses after 5 years of use to reduce the risk of hose failure. Inspect and replace inlet hoses if bulges, kinks, cuts, wear, or leaks are found. When replacing your inlet hoses, mark the date of replacement on the label with a permanent marker.

Connect the inlet hoses to the washer

1. Insert a flat washer into each end of the inlet hoses. Check that washers are firmly seated in couplings.

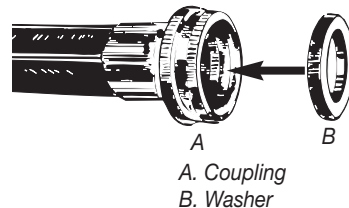

2. Attach a hose to the hot water inlet valve. Tighten the coupling by hand.

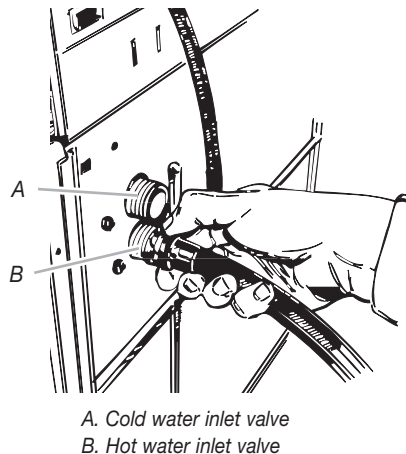

3. Attach the other hose to cold water inlet valve. Tighten the coupling by hand.
4. Use pliers to make an additional two-thirds turn to each coupling.

NOTE: Inlet valve threads are plastic. Do not strip or cross-thread.

Connect the drain hose

1. Put "hook" end of drain hose into standpipe.
2. Estimate the length of drain hose needed when washer is in final position. Hose must be cut exactly to length so "hook" end is held tightly over edge of standpipe.

If drain hose is too long, cut straight end of hose. (Do not cut the "hook" shaped end of the drain hose.)

NOTE: Do not force excess length of drain hose down the standpipe. This could cause siphoning.

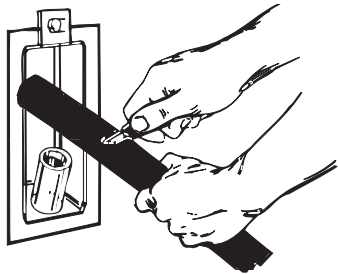

3. Place the hose clamp over the washer drain connector. Push the drain hose onto the washer connector. Use pliers to open clamp and slide clamp over drain hose. Check for good fit.

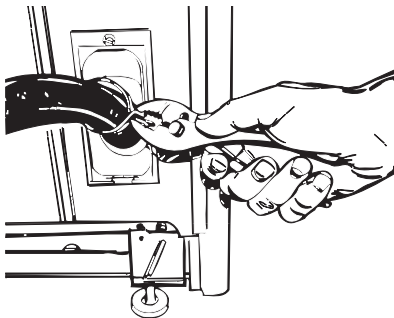

4. Measure and mark a point approximately 16 inches (40.6 cm) from the plug end of the shipping strap. Cut the shipping strap at this point.

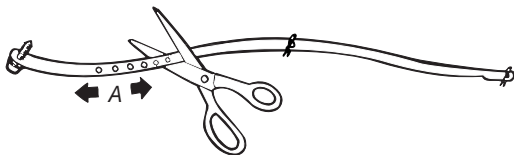

A. 16" (40.6 cm)

5. Check that hose is not twisted or kinked and is securely in place. With the "hook" end of drain hose in the standpipe, tightly wrap the shipping strap around the standpipe. Push plug into the tightest hole in the shipping strap.

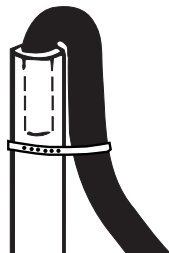

Connect the inlet hoses to the water faucets

1. Before attaching water inlet hoses to the water faucets, run water through both faucets into a bucket. This will get rid of particles in water lines that might clog hoses. Mark which is the hot water faucet.
2. Attach bottom hose (inlet marked "H") to hot water faucet. Tighten coupling to faucet by hand.
3. Attach top hose (inlet marked "C") to cold water faucet. Tighten coupling to faucet by hand.
4. Use pliers to make an additional two-thirds turn to each coupling.

Level the Washer

Install the front leveling feet

1. Stack two corner posts on top of each other. Tilt washer backward and insert corner posts 3 inches (7.6 cm) in from one side of washer as shown. Repeat with other corner posts on other side of washer.



2. Use the leveling legs and nuts from parts package. Screw nut down to within 1/2" (1.3 cm) of base.

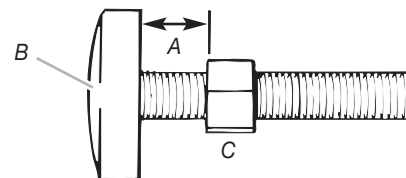

A. 1/2" (1.3 cm)

B. Base

C. Nut

3. Insert legs into correct holes at each front corner of washer until nuts touch washer. Do not tighten nuts until the washer is leveled.



4. Tilt washer backward and remove corner posts. Gently lower washer to floor.
5. Move washer to its permanent location. Remove cardboard or hardboard from under washer.

Level the washer

1. Tilt washer forward raising back legs 1" (2.5 cm) off of floor. To adjust rear self-leveling legs, gently lower washer to floor.
2. Check levelness of the washer by placing a carpenter's level on top of the washer, first side to side; then front to back.

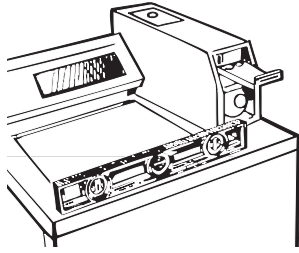

3. If washer is not level, adjust the front legs up or down. Make final check with level.
4. When washer is level, use a wrench to turn the nuts on front legs up tightly against washer base. If nuts are not tight against washer base, the washer may vibrate.

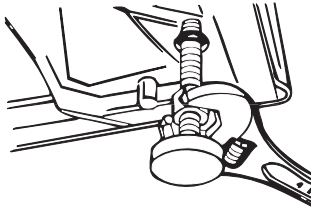

Remove the service door of the meter case

1. Lift the service door up at the back and remove. Install money accepting device (refer to manufacturers instructions for proper installation). For machines using coin slides, use adapter kit (provided with unit). Replace meter case service door.

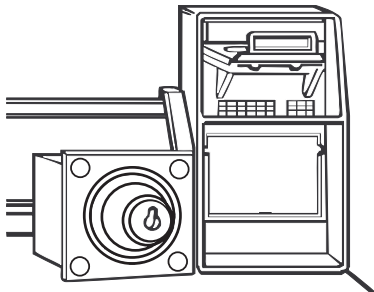

Complete Installation

1. Check the electrical requirements. Be sure that you have the correct electrical supply and the recommended grounding method. See "Electrical Requirements."
2. Check to be sure all parts are now installed. If there is an extra part, go back through the steps to see which step was skipped.
3. Check to be sure you have all of your tools.
4. Check to be sure that the yellow shipping strap was completely removed from the lower back of the washer.
5. Dispose of or recycle all packaging materials.
6. Check to be sure the water faucets are on.
7. Check for leaks around faucets and inlet hoses.

! WARNING



Electrical Shock Hazard

Plug into a grounded 3 prong outlet.

Do not remove ground prong.

Do not use an adapter.

Do not use an extension cord.

Failure to follow these instructions can result in death, fire, or electrical shock.

8. Plug power supply cord into a grounded 3 prong outlet.

Making a cycle check

1. Run the washer through 1 complete cycle.
2. Measure ½ of the normal recommended amount of powdered or liquid detergent and pour it into the washer basket.
3. Close the lid.
4. When the cycle is complete, check all hoses and connections for proper operation and that they do not leak.

Adjusting Timer Clutch

Electro/Mechanical models have a timer that provides a 9-minute wash in the NORMAL Cycle. To check the cycle, remove the timer from the meter case of the washer to manually start the timer. Start the washer and allow it to complete the Normal cycle.

Timers can be started by turning the clutch assembly counterclockwise until the washer starts to fill with water.

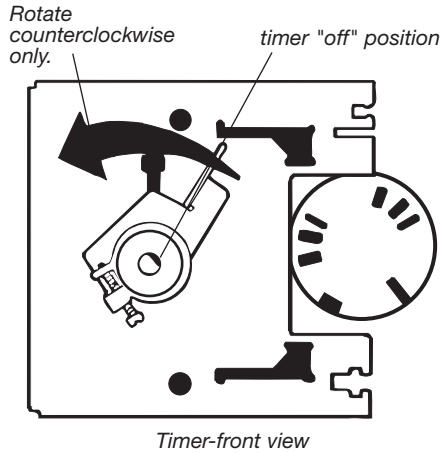

To adjust the clutch:

If the washer fails to start or does not give the proper washer cycle time, the clutch assembly of the timer can be adjusted.

1. Unplug washer or disconnect power.
2. Remove the timer from the meter case.
3. Adjust the clutch adjustment screw clockwise if the washer does not start after the coin slide mechanism has been fully actuated in or out.
4. Adjust the clutch adjustment screw counterclockwise if the washer segment of the Normal cycle was less than 9-minutes.

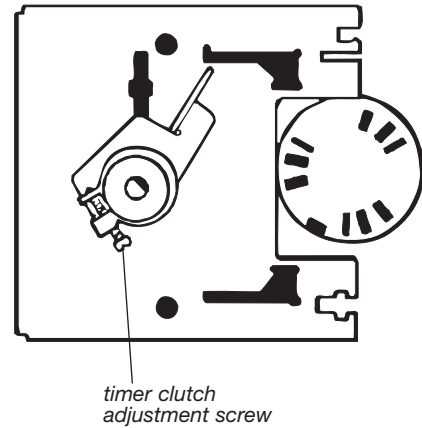

⚠ WARNING



Electrical Shock Hazard

- Disconnect power before servicing.
- Replace all parts and panels before operating.
- Failure to do so can result in death or electrical shock.

NOTE: The washer was tested at the factory. Some time may have been left so that the washer will start to operate before the coin slide is operated. If this happens, take off the access panel from the top of the meter case and set the clutch to OFF position by hand. Then proceed with timer clutch check.

Additional Features

! WARNING



Electrical Shock Hazard

Disconnect power before servicing.

Replace all parts and panels before operating.

Failure to do so can result in death or electrical shock.

For WARM RINSE where applicable:

- Remove screws from each end of the console bottom.
- Pull the console bottom forward; lift and tilt back.
- Connect J1 to J2

To SAVE WATER where applicable:

- Locate water level switch on back of washer.
- Turn shaft 45° counterclockwise.

Checklist for washer operation:

Check the following if the washer is not operating properly:

1. Power supply cord is plugged in.
2. Circuit breaker is not tripped or fuse is not blown.
3. Timer has been advanced to start of a cycle.
4. Water faucets are turned on.
5. Inlet and drain hoses are not kinked.
6. Washer lid is closed.
7. Inlet valve is frozen if not protected from the weather.
8. Suds level. Excess suds will slow the spin and cause poor rinsing. Operate the washer through a complete cycle with no detergent. Use less detergent or a controlled suds type detergent in future loads.

If you need assistance:

The Whirlpool Consumer Interaction Center will answer any questions about operating or maintaining your washer not covered in the Installation Instructions. The Whirlpool Consumer Interaction Center is open 24 hours a day, 7 days a week. Just dial 1-800 NO BELTS (1-800-662-3587) - the call is free.

When you call, you will need the washer model number and serial number. Both numbers can be found on the serial-rating plate located on your appliance.

Typical full load sizes

Load type	Loading suggestion
Mixed Load	3 double sheets 4 pillowcases 6 pair shorts 8 T-shirts 2 shirts 2 blouses 8 handkerchiefs
Permanent Press	2 double or 1 king-size sheet 1 tablecloth 1 dress 1 blouse 2 slacks 3 shirts 2 pillowcases
Heavy Work Clothes	3 pair of pants 3 shirts 1 coverall 4 pair of jeans 1 overall
Knits	3 blouses 4 slacks 6 shirts 4 tops 4 dresses

Operating tips

! WARNING



Fire Hazard

Never place items in the washer that are dampened with gasoline or other flammable fluids.

No washer can completely remove oil.

Do not dry anything that has ever had any type of oil on it (including cooking oils).

Doing so can result in death, explosion, or fire.

It is recommended that fiberglass items not be washed in coin-operated washers. If these items are washed in the washer, run the washer through a complete cycle to rinse any residue away that might be left in the washer.

Moving the washer to a new location

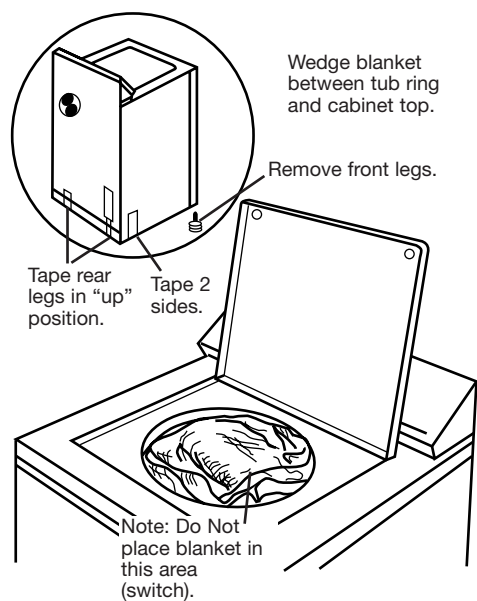

- Remove the front legs from the base of the washer.
- Place both rear leveling legs in the upper position and tape securely.
- Apply tape to the side and bottom of the cabinet near the rear.
- Open washer lid, wedge a blanket between the tub ring and the cabinet top restricting the tub movement.
- Handle washer carefully. Do Not drop washer while using hand truck.



商用洗衣機 安裝說明書

型號120-伏特，60-赫茲

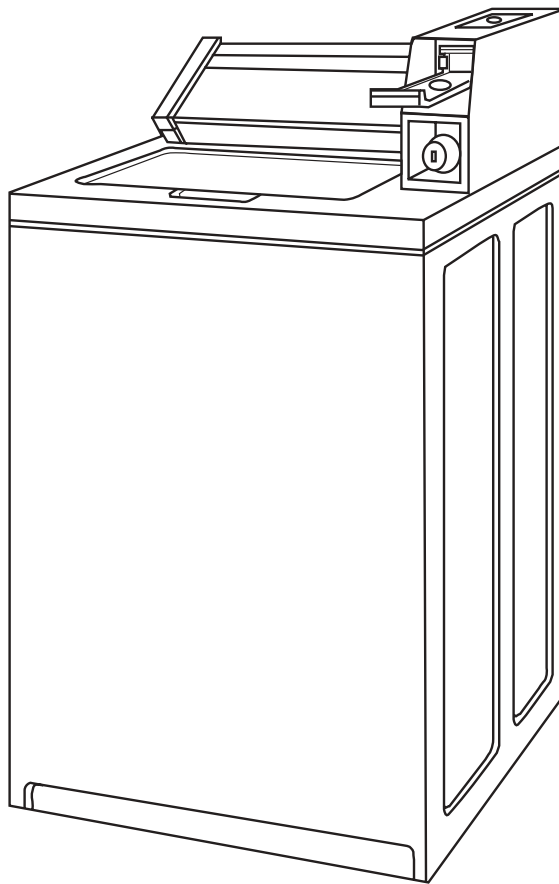

在安裝洗衣機之前，寫下型號和序號。
這兩個數字都列在位于上蓋下的型號 / 序號銘牌之上。

型號# _____

序號# _____

購買日期 _____

目錄

洗衣機安全	2
安裝要求	3
工具和部件	3
位置要求	3
排水系統	4
電氣要求	5
安裝說明	6
在您開始安裝前	6
取下運輸包裝帶	6
連接軟管	6
調整洗衣機水平	7
完成安裝	8
調整定時器離合器	9
其它特性	10

洗衣機安全

您及他人的安全是很重要的。

我們在本手冊中以及在您的家用電器上提供了許多重要的安全資訊。一定要閱讀並遵守所有這些安全資訊。



這是安全警報標志。

這警報標志警戒你潛在危險，可能會導致你和他人死亡或受傷。

所有安全資訊會在安全警報標志或“危險”或“警告”字眼後面。
這些字眼的意思是：

⚠ 危險

如果您不立即遵守指令，將會有生命危險或造成嚴重傷害。

⚠ 警告

如果您不遵守指令，將會有生命危險或造成嚴重傷害。

所有這些安全資訊告訴您潛在危險是什麼，如何使您減少傷害的可能。以及如果不遵守，將會有什麼樣的後果。

重要安全說明

警告： 為了在使用洗衣機時減少起火、觸電或人員受傷的危險，請遵守以下基本注意事項，包括：

- 在使用洗衣機之前，請閱讀所有說明資料。
- 不要清洗曾經使用汽油、干燥清潔溶劑或其它易燃、易爆物質清潔、清洗、浸泡或者沾污過的物品，因為這些物質散發的蒸汽可能引燃火焰或爆炸。
- 不要向清洗水中加入汽油、干燥清潔溶劑或其它易燃、易爆物質。這些物質散發的蒸汽可能引燃火焰或爆炸。
- 在一定條件下，2周或2周以上的熱水系統，如果不使用，可能產生氫氣。氫氣是爆炸性的。如果熱水系統經過這樣長時間的放置，在使用洗衣機之前，打開所有的熱水龍頭，讓水流動幾分鐘。這會釋放所有積累的氫氣。因為這種氣體是可燃的，因此此時不要抽煙或使用明火。
- 不要讓孩子在洗衣機上面或裡面玩耍。當孩子在洗衣機附近時，需要特別當心。
- 在洗衣機被移走或者棄置之前，取下洗衣機的門或上蓋。
- 如果轉鼓、筒或者攪拌器仍在運動，請不要將手伸入洗衣機中。
- 不要將洗衣機安裝或存放在露天環境下。
- 不要變更控制單元。
- 除非在本說明書中或者出版的用戶維修說明中有您能夠理解的具體建議並且您有進行修理的技能，否則請不要修理或者更換洗衣機的任何部件或者試圖進行任何維修。
- 請參看“電氣要求”以了解接地說明。

請保存這些說明

安裝要求

工具和部件

在開始安裝前，備齊所需的工具和部件。請閱讀以下要求，並按 requirements 提供以下工具。

所需工具：

- 水平儀
- 多用途刀
- 剪刀
- 8吋或 10吋可調節扳手
- 平頭改錐
- 鉗子
- 桶

隨機器提供的部件：

從洗衣機中取出部件袋。檢查是否包括所有部件。

- 軟管夾子 (1)
- 進水口軟管 (2)
- 扁平自來水軟管墊圈 (4)
- 帶有螺母的前部水平腳 (2)
- 排水軟管 (1)

位置要求

重要提示： 不要將洗衣機安裝或存放在露天環境下。

正確安裝是您的責任。

您將需要：

- 向洗衣機提供120°F (49°C)水的水加熱器。
- 一個距離洗衣機後方電源插銷4英尺（1.2米）範圍內帶有接地的電源插座。
參看“電氣要求”。
- 距離洗衣機熱水和冷水閥門4英尺（1.2米）範圍內的熱水和冷水龍頭，水壓為10-100 磅力 / 英寸（69-690 千帕）。
- 在洗衣機整體範圍內最大傾斜不超過1英寸（2.5厘米）的水平地面。
- 能承受315磅（143公斤）洗衣機重量（洗衣機，水和負荷）的結實地面。
- 對於單個的洗衣機的安裝，需要一個最小12英寸（30厘米）立管，能提供氣墊，防止噪聲和避免損壞閥門。

不要在32°F (0°C)或低于這個溫度的條件下存放或操作洗衣機。洗衣機內可能殘留部分水並且在低溫下可能會引起損害。

凹室和壁櫥安裝說明

可將洗衣機安裝在凹室或壁櫥內。

安裝間隙以英寸為單位且為最低要求。為了便于安裝、維修和符合地方法規和指導，應考慮留出額外的間隙。

如果安裝了壁櫥門，則要求在頂部和底部備有無遮擋的空氣口，如有同等量空氣開口的百葉門也是可以接受的。

最小安裝間距

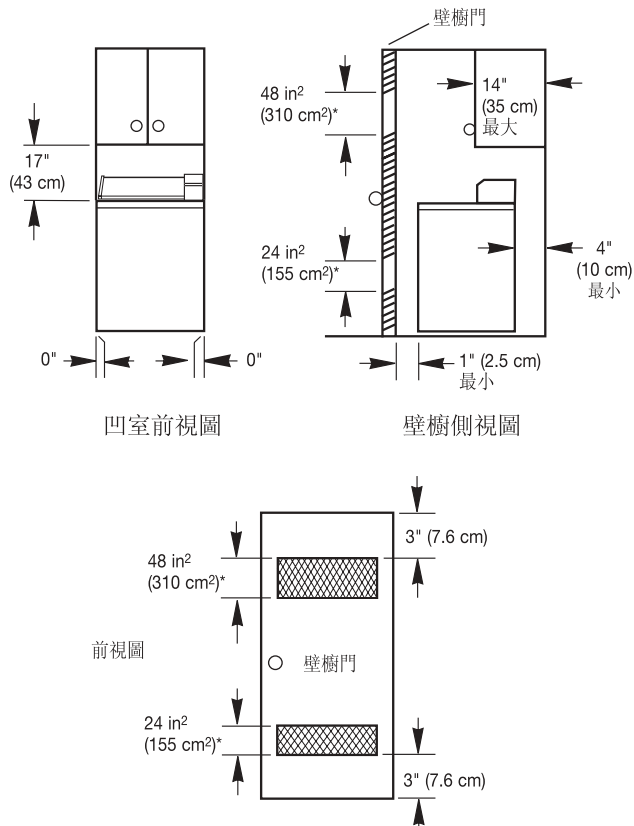

壁櫥門上至少應有一個開口。
也可以接受帶等量空氣開口的百葉門。

- 為了便于安裝和維修，應考慮留出額外的間隙。
- 可能需要考慮與牆壁、門和地板之間的額外間距。
- 建議在洗衣機的每一面額外留出1英寸（2.5厘米）的間隙以減少噪音傳送。
- 也應該考慮與相鄰物體之間的間隙。

產品尺寸

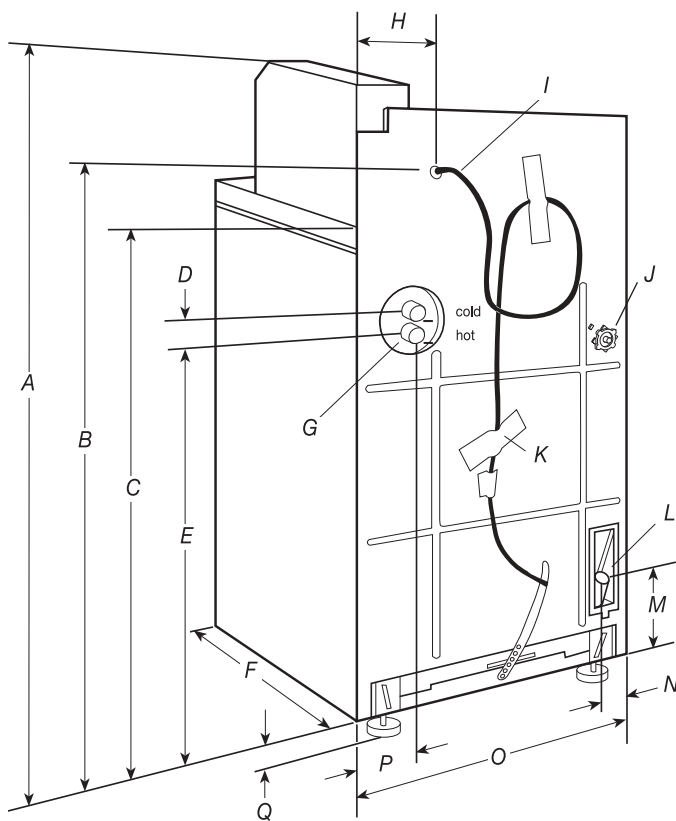

- A. 43英寸（109 厘米）
- B. 38英寸（97厘米）
- C. 35英寸（89 厘米）
- D. 1英寸（4 厘米）
- E. 27英寸（70.5 厘米）
- F. 25英寸（65 厘米）
- G. 進水口
- H. 7英寸（18 厘米）
- I. 電源綫
- J. 水位開關和把手
- K. 標牌
- L. 排水管連接器
- M. 7英寸（18 厘米）
- N. 5英寸（12.7 厘米）
- O. 27英寸（68.5 厘米）
- P. 5英寸（13.3 厘米）
- Q. 1英寸（2.5 厘米）

排水系統

豎管排水系統

豎管排水要求的豎管直徑為2英寸（5厘米）。最小排水能力不能小于17加侖（64升）每分鐘。

從洗衣機的底部開始計算，豎管頂部必須至少高39英寸（99厘米），並且不超過72英寸（183厘米）。

電氣要求

警告



觸電危險

插入一個接地的三相分流插座。

不要拆除接地分流裝置。

不要使用適配器。

不要使用加長電源綫。

不遵守以下要求，會導致死亡，起火或觸電。

重要提示：洗衣機必須按照地方法規和指導的要求進行接地，如果沒有地方法規，則按照國家電氣法規，ANSI/NFPA 70的最新版本執行。

- 如果法規允許且使用了單獨的地線，我們建議由一位有資格的電氣安裝人員來確定接地通道是否足以滿足要求。
- 不要將接地連接于煤氣管道。
- 不要在中線或地線電路中使用保險絲。

可從以下地址獲得上述法規標準：

National Fire Protection Association
One Batterymarch Park, Quincy, MA 02269

- 需要有一個帶保險絲的電路：120伏特，60赫茲，必須是交流電，15或20 安培。我們建議使用一個延時保險或斷路開關。我們建議應提供一條專供本洗衣機使用的單獨電路。
- 洗衣機配有帶3相接地插銷的電源綫。
- 為了使觸電危險最小，插銷必須插入匹配的、3相、帶有接地的接線板，接地符合地方法規和指導。如果沒有匹配的插座，用戶個人有責任和義務讓有資格的電氣人員安裝帶有正確接地的插座。

建議接地方法

洗衣機安裝時必須按照地方法規的要求進行接地，如果沒有地方法規，則按照國家電氣法規，ANSI/NFPA 70的最新版本和所有的地方法規和指導執行。

接地說明

對於接地，以導線相連的洗衣機：

該類洗衣機必須接地。一旦出現失靈或故障，接地為電流提供一條電阻最小的電路，從而減少觸電的危險。本洗衣機配有一根帶設備接地導體的導綫和接地插銷。插銷必須插入正確的插座，其安裝和接地必須符合所有地方法規和指導的規定。

警告：設備接地導體的不正確安裝會導致觸電危險。如果您對電器是否正確接地存有疑慮，請讓有資格的電工或維修人員進行檢查。

不要改動洗衣機提供的插銷，如果所提供的插銷與電源插座不匹配，請一位有資格的電氣技術人員安裝一個合適的插座。

對於進行永久性連接的洗衣機：

該類洗衣機必須連接到接地的金屬永久連線系統，或者連接到一個與電路導體相連的接地導體，且連接到洗衣機上的設備接地終端或導綫。

安裝說明

開始安裝前



警告

過重危險

應有兩人或多人移動和安裝洗衣機。

否則會導致背部或其它部位受傷。

注意：在地面上移动洗衣机之前，将其置于纸板之上，以免划傷地面。

取下運輸包裝帶

1. 取下貼在運輸包裝帶上的膠帶。使用洗衣機內部的兩個扁銷完全取下運輸包裝帶。

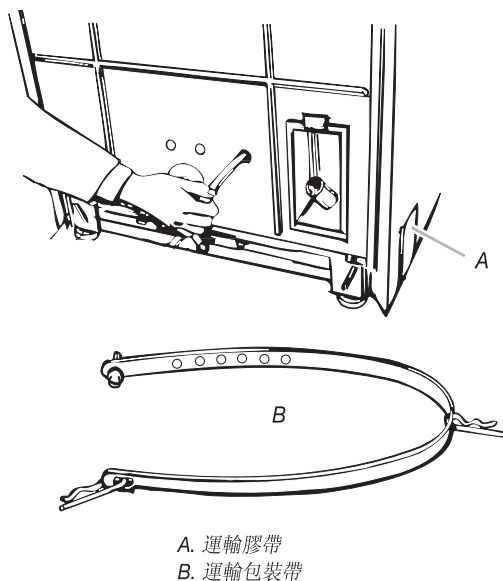

2. 從洗衣機後部用力扯下運輸包裝帶的末端。運輸包裝帶的末端必須完整的從洗衣機上取下，以松開自動水平支腳。

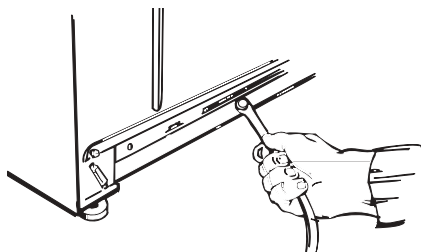

保留運輸包裝帶以備后用。

連接水管軟管

- 使用您的洗衣機所帶的新軟管和墊圈。
- 使用5年後更換入口軟管，以減少軟管故障的風險。如果發現膨脹，打結，割傷，磨損，或者洩漏，請檢查並更換入口軟管。當更換您的入口軟管時，請在標籤上對更換日期做永久性的標記。

連接洗衣機的進水管

1. 在進水管的每一端加上一個扁平墊圈。檢查所有墊圈是否已經牢固的固定在接口處。

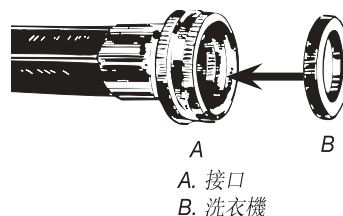

2. 將一根軟管連接到熱水進水閥。用手擰緊連接處。

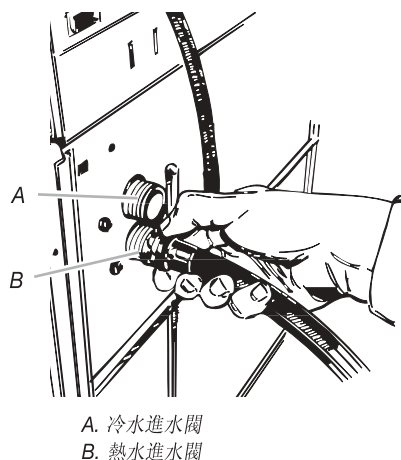

3. 將另一根軟管連接到冷水進水閥。用手擰緊連接處。
4. 使用鉗子將每個連接處再擰緊三分之二圈。

注意：進水閥螺紋是塑料的。不要將其磨損或錯扣。

連接排水管

1. 將排水管的“鉤子”一端放入豎管。
2. 估計洗衣機在最終位置時所需排水管長度。軟管必須在“鉤子”一端緊緊扣住豎管邊緣的位置切斷。

如果排水管過長，切斷軟管的直端。（不要切斷排水管的“鉤子”形末端。）

注意： 不要把過長的排水管強行伸入豎管。這可能導致虹吸。

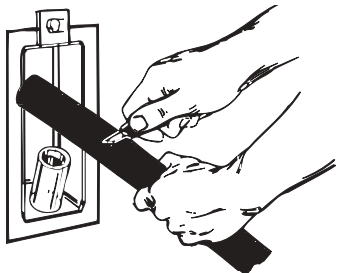

3. 將軟管夾子放置於洗衣機排水連接器上。將排水管推至洗衣機連接器。使用鉗子打開夾子，使其滑動後夾住排水管。檢查其安裝是否良好。

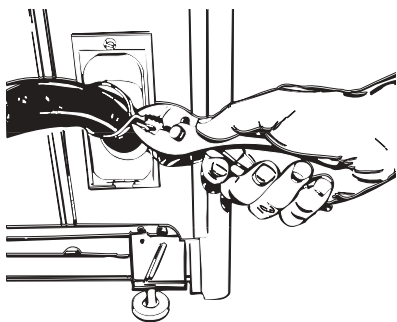

4. 從運輸包裝帶的插入末端開始測量並在大約16英寸(40.6)厘米處進行標記。在此處切斷運輸包裝帶。

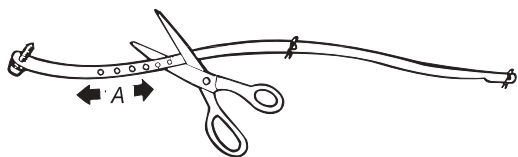

A. 16英寸(40.6厘米)

5. 檢查軟管沒有扭曲或堵塞，並安裝牢固。把排水管帶“鉤子”的一端插入豎管內，纏緊豎管上纏繞的運輸包裝帶。將運輸包裝帶推入最緊的一扣。

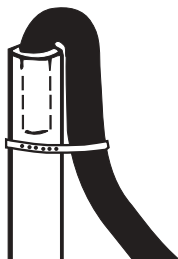

將進水管與水龍頭連接。

1. 在連接進水管與水龍頭之前，將兩個水龍頭中的水放入一個水桶之中。這可以去除水管線中可能堵塞軟管的顆粒物質。對熱水水龍頭進行標記。
2. 連接底部軟管（進水口標記為“H”）至熱水水龍頭。用手將連接處擰緊。
3. 連接頂部軟管（進水口標記為“C”）至冷水水龍頭。用手將連接處擰緊。
4. 使用鉗子將兩個連接處再擰緊三分之二圈。

調整洗衣機水平

安裝前方水平腳

1. 將兩個角柱疊放在一起。向后傾斜洗衣機並將角柱插入3英寸(7.6厘米)，如圖所示。重複這一操作，將另一個角柱安裝在洗衣機另一側。

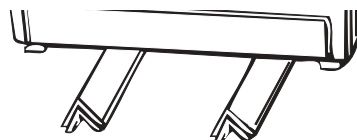

2. 使用部件包中的水平腿和螺母。將螺母向下旋入底座1/2英寸(1.3厘米)位置之內。

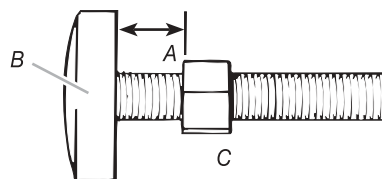

A. 1/2英寸(1.3厘米)
B. 底座
C. 螺母

3. 將水平腿正確插入洗衣機前角的孔中，直至螺母接觸到洗衣機。在洗衣機達到水平之前，不要擰緊螺母。



4. 向后傾斜洗衣機並取下角柱，輕輕將洗衣機放低至地面。
5. 將洗衣機移動到它的永久性位置。取出洗衣機下的紙板或硬紙板。

調整洗衣機水平

1. 向前傾斜洗衣機，使其後腿離開地面1英寸（2.5厘米）。為了調節後面的自動水平支腳，輕輕把洗衣機放回地面上。
2. 把木工水平尺放置于洗衣機頂部，檢查洗衣機的水平度，先檢測兩側，再檢測前後。

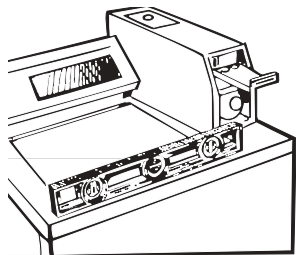

3. 如果洗衣機不水平，調高或者調低前腿。最后用水平儀進行檢查。
4. 當洗衣機水平後，使用扳手將前腿上的螺母擰緊，固定于洗衣機底座。如果螺母未能固定于洗衣機底座，洗衣機可能晃動。

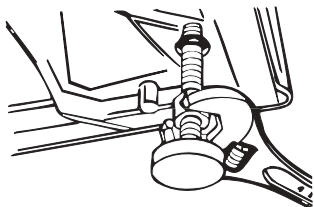

取下儀表箱上的檢修門。

1. 提起後面的服務門並取下。安裝硬幣接收裝置（請參閱製造商說明以進行正確的安裝）。對於使用硬幣滑道的洗衣機，請使用適配器組件（隨洗衣機提供）。複位儀表箱檢修門。

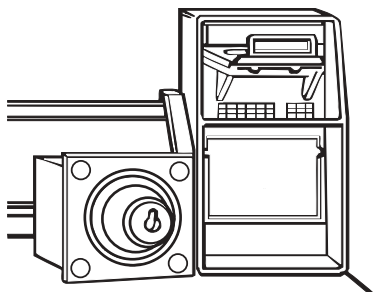

完成安裝

1. 檢查電氣要求。確保您的供電正確並且使用了推荐的接地方法。參看“電氣要求”
2. 檢查並確保所有部件已經安裝。如果有多出的部件，再次回顧各個步驟，看哪一個步驟被跳過。
3. 檢查並確保您所有工具清理完畢。
4. 檢查並確保黃色的運輸包裝帶完全從洗衣機的後部下面取下。
5. 棄置或回收所有包裝材料。
6. 檢查並確保水龍頭是否打開。
7. 檢查水龍頭和進水管是否漏水。

警告



觸電危險

- 插入一個接地的三相分流插座。
- 不要拆除接地分流裝置。
- 不要使用適配器。
- 不要使用加長電源綫。
- 不遵守這些要求，會導致死亡，起火或觸電。

8. 將電源綫插入一個接地的三相插座中。

進行周期檢查

1. 使洗衣機運行1個完整的周期。
2. 將通常建議的洗衣粉或者液體洗滌劑 $\frac{1}{2}$ 的量，倒入洗衣機的籃中。
3. 關上蓋子。
4. 當周期結束時，檢查所有的軟管和連接，確保操作正確且沒有泄漏。

調節計時器離合器

電動 / 機械型號有一個定時器，可使洗衣機在普通周期模式下運行 9 分鐘。為了檢查這個周期，將定時器從儀表箱中取下來，手動啟動定時器。啟動洗衣機並使其完成普通周期。

定時器可以通過逆時針轉動離合器組件啟動，直至洗衣機開始加水。

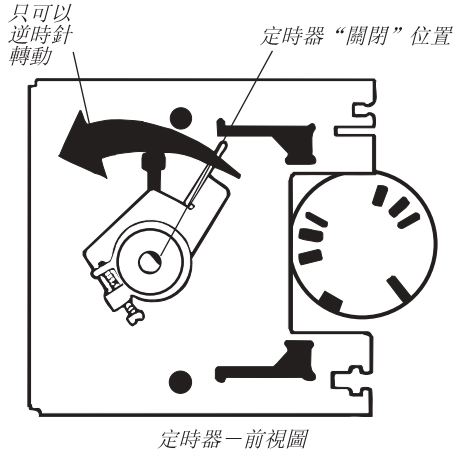

警告



觸電危險

檢修前拔下電源。

操作前復位所有部件和面板。

不遵守這些要求可能導致死亡或觸電。

注意：洗衣機在工廠已經進行過測試。可能剩余一些使用時間，所以在硬幣滑道啟用之前，洗衣機就可能開始運行。如果發生這樣的情況，請取下儀表箱頂部的連接面板並手動將離合器設置于 OFF（關閉）位置。然後對定時器離合器進行檢查。

調節離合器

如果洗衣機啟動失敗或未能給出正確的洗衣機周期時間，可以調節定時器的離合器組件。

1. 拔下洗衣機插頭或者切斷電源。
2. 從儀表箱中取下定時器。
3. 如果硬幣滑道裝置被完全啟動後，洗衣機未能啟動，請按順時針方向調整離合器調節螺絲。
4. 如果洗衣機的正常周期小於9分鐘，請逆時針方向調整離合器調節螺絲。

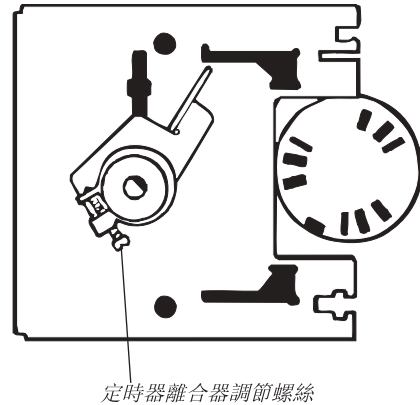

其它特性

警告



觸電危險

檢修前拔下電源。

操作前複位所有部件和面板。

不遵守這些要求可能導致死亡或觸電。

熱漂洗，對於適用型號：

- 取下每個控制台的底部的螺絲。
- 將控制台底部向前推；抬起並傾斜背面。
- 連接J1 至 J2

節水，對於適用型號：

- 找到洗衣機背面的水位開關。
- 將把手逆時針旋轉45°。

洗衣機操作的檢查列表：

如果洗衣機運行不正常，請檢查下列各項：

1. 電源綫是否插好。
2. 電路斷路器沒有切斷或保險絲沒有熔化。
3. 定時器已經預設為開始一個周期。
4. 水龍頭開啟。
5. 進水和排水管沒有打結。
6. 洗衣機上蓋關閉。
7. 如果沒有採取防凍措施，進水閥可能凍住。
8. 泡沫量大小。過多的泡沫會降低轉速並導致漂洗效果不佳。不要使用洗滌劑，使洗衣機運行一個完整的周期。以後往洗衣機裏放衣物時，洗滌劑或者可控製泡沫的洗滌劑少放一些。

如果您需要協助：

關於洗衣機的操作和維護問題，如果安裝說明中還有一些沒有提到，Whirlpool公司客戶交流中心將予以解答。Whirlpool公司客戶交流中心每周7天、每天24小時開放。只需撥打1-800免費電話(1-800-662-3587)即可。

當您撥打電話時，您需要告知洗衣機型號和序號。兩個號碼都可以在您的洗衣機的序號一銘牌上找到。

典型的全負荷尺寸

裝載類型	建議裝載
混合	雙人床單(3) 枕頭套(4) 短褲(6) T恤衫(8) 襯衫(2) 短衫(2) 手帕(8)
免燙	雙人(2)或特大 尺寸(1)床單 桌布(1) 外套(1) 短衫(1) 休閒褲(2) 襯衫(3) 枕頭套(2)
難清洗衣物	褲子(3) 襯衫(3) 連體工作服(1) 牛仔褲(4) 罩衣(1)
織物	短衫(3) 休閒褲(4) 襯衫(6) 上衣(4) 外套(4)

操作提示

警告



起火危險

不要將沾有汽油或其它易燃液體的物品放置于洗衣機內。

任何洗衣機都不可能完全除掉油污。

不要使用洗衣機烘乾曾經沾有任何油污的任何物品（包括食用油）。

這樣做可能導致死亡、爆炸或起火。

建議不要在投幣洗衣機中清洗玻璃纖維物品。如果在洗衣機中清洗這些物品，就要讓洗衣機運行一個完整周期，使得洗衣機內任何的殘留物被漂洗干净。

移動洗衣機至新的位置

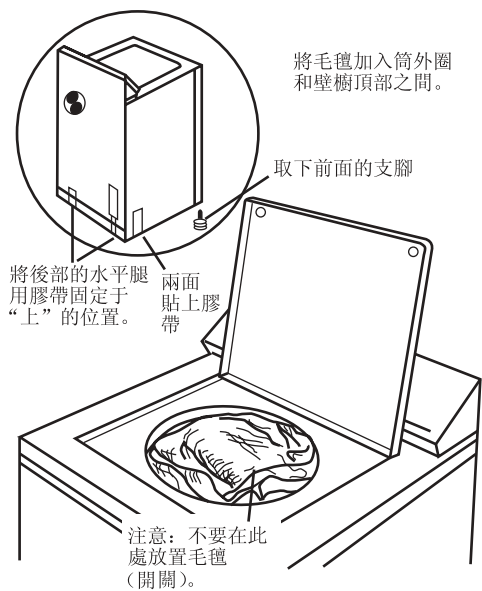

- 從洗衣機的底座上取下前面的支腳。
- 將兩個後部水平腿放至上方位置並用膠帶固定。
- 把膠帶貼在壁櫥後部的側面和底部。
- 打開洗衣機蓋子，將毛氈加入筒外圈和壁櫥頂部之間，限制滾筒移動。
- 小心搬運洗衣機。使用手推車時，不要使其跌落。

