

PRODUCT MODEL NUMBERS

MTW5600T MTW5840T
 MTW5700T MTW5900T
 MTW5800T

Electrical: 120-volt, 60 Hz, AC-only, 15 or 20 amp fused electrical supply. A time-delay fuse or circuit breaker and separate circuit are recommended.

Water: A water heater set to deliver 120°F (49°C) water to the washer. Hot and cold faucets located within 3 ft (90 cm) of the hot and cold water fill valves, and pressure of 20-100 psi (138-690 kPa) for best performance.

RECESSED AREA AND CLOSET INSTALLATION

For closet installation, with a door, the minimum ventilation openings in the top and bottom of the door are required (view B). Louvered doors with equivalent air ventilation openings in the top and bottom are acceptable.

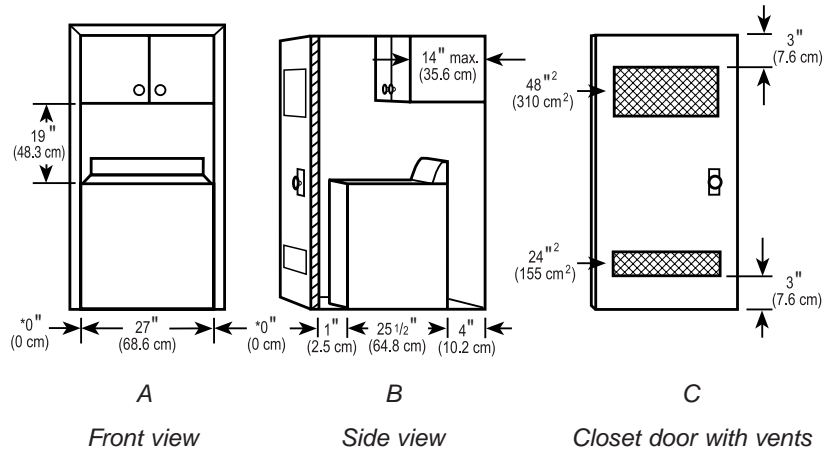

DRAIN SYSTEM OPTIONS

Standpipe drain system - wall or floor (view A & B)

The standpipe drain requires a minimum diameter standpipe of 2" (5 cm). The minimum carry-away capacity can be no less than 17 gal. (64 L) per minute.

The top of the standpipe must be at least 39" (99 cm) high and no higher than 96" (244 cm) from the bottom of the washer.

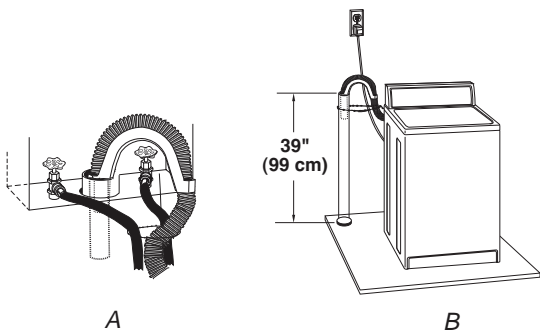

Laundry tub drain system (view C)

The laundry tub needs a minimum 20 gal. (76 L) capacity. The top of the laundry tub must be at least 39" (99 cm) above the floor and no higher than 96" (244 cm) from the bottom of the washer.

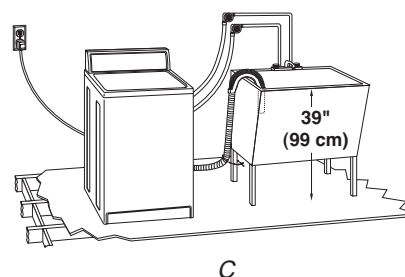

Floor drain system (view D)

The floor drain system requires a siphon break that may be purchased separately. The siphon break must be a minimum of 28" (71 cm) from the bottom of the washer. Additional hoses might be needed.

