

Operator's Manual



3 HP (Max. Developed)

10" Blade

4800 R.P.M.

COMPOUND

MITER SAW

Model No.

137.242750

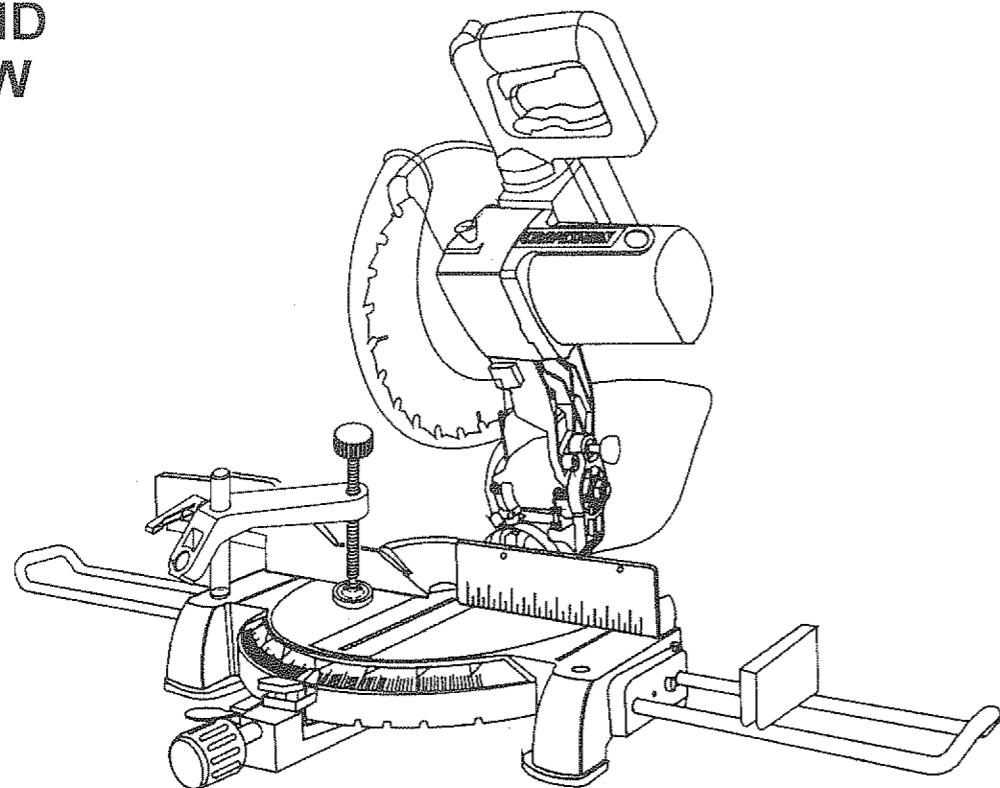

CAUTION:

Before using this Miter Saw,
read this manual and follow
all its Safety Rules and
Operating Instructions

- Safety Instructions
- Installation
- Operation
- Maintenance
- Parts List

Customer Help Line
1-800-843-1682

Sears, Roebuck and Co., Hoffman Estates, IL 60179 U.S.A.

Visit our Craftsman website: www.sears.com/craftsman

Part No. 13724275001

TABLE OF CONTENTS

SECTION	PAGE	SECTION	PAGE
Warranty	2	Know Your Compound Miter Saw.....	8
Product Specifications	2	Glossary of Terms.....	9
Power Tool Safety	3	Assembly and Adjustments.....	10
Compound Miter Saw Safety.....	4	Operation.....	16
Electrical Requirements and Safety.....	5	Maintenance	23
Accessories and Attachments.....	6	Troubleshooting Guide.....	24
Tools Needed For Assembly.....	6	Parts List.....	25
Carton Contents	7		

WARRANTY

FULL TWO YEARS WARRANTY

If this tool fails due to a defect in material or workmanship within two years of date of purchase, Sears will at its option repair or replace it free of charge.

Return this tool to a Sears Service Center for repair, or to place of purchase for replacement.

This warranty gives you specific legal rights, and you may also have other rights which may vary from state to state.

Sears, Roebuck and Co., Dept. 817 WA, Hoffman Estates, IL 60179

▲ WARNING

Some dust created by power sanding, sawing, grinding, drilling and other construction activities contains chemicals known to the state of California to cause cancer, birth defects or other reproductive harm. Some examples of these chemicals are:

- Lead from lead-based paints
- Crystalline silica from bricks, cement and other masonry products
- Arsenic and chromium from chemically treated lumber

Your risk from these exposures varies, depending on how often you do this type of work. To reduce your exposure to these chemicals, work in a well ventilated area and work with approved safety equipment such as dust masks that are specially designed to filter out microscopic particles.

PRODUCT SPECIFICATIONS

MOTOR

Power Source.....	120 V AC, 60HZ, 15 Amp
Horsepower.....	3HP (Max. Developed)
Speed.....	4800 RPM (No load)
Brake.....	Electric
Double Insulated.....	Yes

MITER SAW

Cutting Capacity:

Crosscut.....	2-5/8" x 5-1/2"
Miter 45° R. & L.	2-5/8" x 3-1/2"
Bevel 45° L.....	1-1/2" x 5-1/2"
45° Miter and 45° Bevel.....	1-1/2" x 3-1/2"

Rotating Table:

Diameter.....	12-5/8"
Miter Detent Stops.....	0, 15, 22-1/2, 31.6, 45° R. & L.
Bevel Positive Stops.....	0, 45°
Base Dimensions.....	19-7/8" x 16-3/8"
Dust Collection.....	Yes
Extension Wings.....	Yes
Net Weight.....	28.6 Lbs

▲ WARNING

To avoid electrical hazards, fire hazards or damage to the tool, use proper circuit protection.

This tool is wired at the factory for 110-120 Volt operation. It must be connected to a 110-120 Volt / 15 Ampere time delay fuse or circuit breaker. To avoid shock or fire, replace power cord immediately if it is worn, cut or damaged in any way.

Before using your tool, it is critical that you read and understand these safety rules. Failure to follow these rules could result in serious injury to you or damage to the tool.

POWER TOOL SAFETY

GENERAL SAFETY INSTRUCTIONS

BEFORE USING THE MITER SAW

Safety is a combination of common sense, staying alert and knowing how to use your miter saw.

▲ WARNING

To avoid mistakes that could cause serious injury, do not plug the tool in until you have read and understood the following.

1. **READ** and become familiar with the entire Operator's Manual. **LEARN** the tool's application, limitations and possible hazards.
2. **KEEP GUARDS IN PLACE** and in working order.
3. **REMOVE ADJUSTING KEYS AND WRENCHES.** Form the habit of checking to see that keys and adjusting wrenches are removed from the tool before turning ON.
4. **KEEP WORK AREA CLEAN.** Cluttered areas and benches invite accidents.
5. **DON'T USE IN DANGEROUS ENVIRONMENT.** Don't use power tools in damp locations, or expose them to rain or snow. Keep work area well lighted.
6. **KEEP CHILDREN AWAY.** All visitors and bystanders should be kept a safe distance from work area.
7. **MAKE WORKSHOP CHILD PROOF** with padlocks, master switches, or by removing starter keys.
8. **DON'T FORCE THE TOOL.** It will do the job better and safer at the rate for which it was designed.
9. **USE THE RIGHT TOOL.** Do not force tool or attachment to do a job for which it was not designed.
10. **USE PROPER EXTENSION CORD.** Make sure your extension cord is in good condition. When using an extension cord, be sure to use one heavy enough to carry the current your product will draw. An undersized cord will result in a drop in line voltage and in loss of power which will cause the tool to overheat. The table on page 5 shows the correct size to use depending on cord length and nameplate ampere rating. If in doubt, use the next heavier gauge. The smaller the gauge number, the heavier the cord.
11. **WEAR PROPER APPAREL.** Do not wear loose clothing, gloves, neckties, rings, bracelets, or other jewelry which may get caught in moving parts. Nonslip footwear is recommended. Wear protective hair covering to contain long hair.

12. **ALWAYS WEAR EYE PROTECTION.** Any power tool can throw foreign objects into the eyes and could cause permanent eye damage.



ALWAYS wear Safety Goggles (not glasses) that comply with ANSI Safety standard Z87.1 Everyday eyeglasses have only impact-resistance lenses.

They ARE NOT safety glasses. Safety Goggles are available at Sears. **NOTE:** Glasses or goggles not in compliance with ANSI Z87.1 could cause serious injury when they break.

13. **WEAR A FACE MASK OR DUST MASK.** Sawing operation produces dust.
14. **SECURE WORK.** Use clamps or a vise to hold work when practical. It's safer than using your hand and it frees both hands to operate tool.
15. **DISCONNECT TOOLS** before servicing, and when changing accessories such as blades, bits and cutters.
16. **REDUCE THE RISK OF UNINTENTIONAL STARTING.** Make sure switch is in OFF position before plugging in.
17. **USE RECOMMENDED ACCESSORIES.** Consult this Operator's Manual for recommended accessories. The use of improper accessories may cause risk of injury to yourself or others.
18. **NEVER STAND ON TOOL.** Serious injury could occur if the tool is tipped or if the cutting tool is unintentionally contacted.
19. **CHECK FOR DAMAGED PARTS.** Before further use of the tool, a guard or other part that is damaged should be carefully checked to determine that it will operate properly and perform its intended function – check for alignment of moving parts, binding of moving parts, breakage of parts, mounting, and any other conditions that may affect its operation. A guard or other part that is damaged should be properly repaired or replaced.
20. **NEVER LEAVE TOOL RUNNING UNATTENDED. TURN POWER "OFF".** Don't leave tool until it comes to a complete stop.
21. **DON'T OVERREACH.** Keep proper footing and balance at all times.
22. **MAINTAIN TOOLS WITH CARE.** Keep tools sharp and clean for best and safest performance. Follow instructions for lubricating and changing accessories.

POWER TOOL SAFETY – cont'd

▲ WARNING

Dust generated from certain materials can be hazardous to your health. Always operate saw in well-ventilated area and provide for proper dust removal.

SPECIFIC SAFETY INSTRUCTIONS FOR THIS MITER SAW

1. **USE ONLY CROSS-CUTTING SAW BLADES.** When using carbide tipped blades, make sure they have a negative hook angle. Do not use blades with deep gullets as they can deflect and contact guard.
2. **DO NOT** operate the miter saw until it is completely assembled and installed according to these instructions.
3. **IF YOU ARE NOT** thoroughly familiar with the operation of miter saws, seek guidance from a supervisor, instructor, or other qualified person.
4. **ALWAYS** hold the work firmly against the fence and table. **DO NOT** perform any operation free hand.
5. **KEEP HANDS** out of the path of the saw blade. If the workpiece you are cutting would cause your hands to be within 6-1/2" inches of the saw blade, the workpiece should be clamped in place before making the cut.
6. **BE SURE** the blade is sharp, runs freely, and is free of vibration.
7. **ALLOW** the motor to come up to full speed before starting cut.
8. **KEEP THE MOTOR AIR SLOTS CLEAN** and free of chips or dust.
9. **ALWAYS MAKE SURE** all handles are tight before cutting, even if the table is positioned in one of the positive stops.
10. **BE SURE** blade and collar are clean and that the arbor screw is tightened securely.
11. **USE** only blade collars specified for your saw.
12. **NEVER** use blades larger or smaller in diameter than 10 inches.
13. **NEVER** apply lubricants to the blade when it is running.
14. **ALWAYS** check the blade for cracks or damage before operation. Replace a cracked or damaged blade immediately.
15. **NEVER** use blades recommended for operation at less than 4800 RPM.
16. **USE** the blade guards at all times.

17. **ALWAYS** keep the blade guards in place.
18. **NEVER** reach around the saw blade.
19. **MAKE SURE** the blade is not contacting the workpiece before the switch is turned ON.
20. **NEVER** unplug the saw with the switch in the ON position.
21. **IMPORTANT:** After completing the cut, release the power switch and wait for the blade to stop before returning the saw to the raised position.
22. **MAKE SURE** the blade has come to a complete stop before removing or securing the workpiece, changing the workpiece angle, or changing the angle of the blade.
23. **NEVER** cut ferrous metals or masonry with this tool.
24. **NEVER** cut small pieces.
25. **PROVIDE** adequate support to the sides of the saw table for long work pieces.
26. **NEVER** use the miter saw in an area with flammable liquids or gases.
27. **NEVER** use solvents to clean plastic parts. Solvents could possibly dissolve or otherwise damage the material.
28. **SHUT OFF** the power before servicing or adjusting the tool.
29. **DISCONNECT** the saw from the power source and clean the machine before leaving it.
30. **MAKE SURE** the work area is clean before leaving the machine.
31. **SHOULD** any part of your miter saw be missing, damaged, or fail in any way, or any electrical component fail to perform properly, shut OFF the switch and remove the plug from the power supply outlet. Replace missing, damaged, or failed parts before resuming operation.

ELECTRICAL REQUIREMENTS

POWER SUPPLY AND MOTOR

SPECIFICATIONS

The AC motor used in this saw is a universal, nonreversible type. See MOTOR in the PRODUCT SPECIFICATIONS section on page 2.

▲ WARNING

To avoid electrical hazards, fire hazards, or damage to the tool, use proper circuit protection. Your saw is wired at the factory for 120V operation. Connect to a 120V, 15 Amp circuit and use a 15 amp. time delay fuse or circuit breaker. To avoid shock or fire, if power cord is worn or cut, or damaged in any way, have it replaced immediately.

ELECTRICAL REQUIREMENTS AND SAFETY

DOUBLE INSULATED □

The power tool is double insulated to provide a double thickness of insulation between you and the tool's electrical system. All exposed metal parts are isolated from the internal metal motor components with protecting insulation.

Replacement parts – When servicing use only identical replacement parts.

Polarized plugs – This saw has a plug that looks like the one shown below:

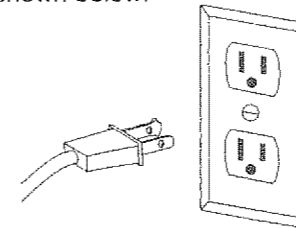

To reduce the risk of electrical shock, this saw has a polarized plug (one blade is wider than the other). This plug will fit in a polarized outlet only one way. If the plug does not fit fully in the outlet, reverse the plug. If it still does not fit, contact a qualified electrician to install the proper outlet. Do not change the plug in any way.

▲ WARNING

Double insulation does not take the place of normal safety precautions when operating this tool.

▲ WARNING

To avoid electrocution:

1. Use only identical replacement parts when servicing a tool with double insulation. Servicing should be performed by a qualified technician.
2. Do not use power tools in wet or damp locations or expose them to rain or snow. This tool is intended for indoor use only.

MOTOR SAFETY PROTECTION IMPORTANT:

To avoid motor damage, the motor should be blown out or vacuumed frequently to keep sawdust from interfering with the motor ventilation.

1. Connect this saw to a 120V, 15 amp. circuit with a 15 amp. time delay fuse or circuit breaker. Using the wrong size fuse can damage the motor.
2. If the motor won't start, release the trigger switch immediately. Unplug the saw. Check the saw blade to make sure it turns freely. If the blade is free, try to start the saw again. If the motor still does not start, refer to the TROUBLESHOOTING GUIDE.
3. If the tool suddenly stalls while cutting wood, release the trigger switch, unplug the tool, and free the blade from the wood. The saw may now be started and the cut finished.

4. **FUSES** may "blow" or circuit breakers may trip frequently if:
 - a. **MOTOR** is overloaded – overloading can occur if you feed too rapidly or make too many start/stops in a short time.
 - b. **LINE VOLTAGE** is more than 10% above or below the nameplate voltage rating. For heavy loads, however, the voltage at motor terminals must equal the voltage specified on the nameplate.
 - c. **IMPROPER** or dull saw blades are used.
5. Most motor troubles may be traced to loose or incorrect connections, overload, low voltage or inadequate power supply wiring. Always check the connections, the load and supply circuit if the motor doesn't run well. Check minimum gauge for the length of cord you are using on the chart below.

GUIDELINES FOR EXTENSION CORDS

Use proper extension cord. Make sure your extension cord is in good condition. When using an extension cord, be sure to use one heavy enough to carry the current your product will draw. An undersized cord will cause a drop in line voltage, resulting in loss of power and cause overheating. The table below shows the correct size to use depending on cord length and nameplate ampere rating. If in doubt, use the next heavier gauge. The smaller the gauge number, the heavier the cord.

Be sure your extension cord is properly wired and in good condition. Always replace a damaged extension cord or have it repaired by a qualified person before using it. Protect your extension cords from sharp objects, excessive heat and damp or wet areas.

Use a separate electrical circuit for your tools. This circuit must not be less than # 12 wire and should be protected with a 15 Amp time delay fuse. Before connecting the tool to the power line, make sure the switch is in the OFF position and the electric current is rated the same as the current stamped on the motor nameplate, running at a lower voltage will damage the motor.

MINIMUM GAUGE FOR EXTENSION CORDS (AWG)

		(When using 120 volts only)			
Ampere	Rating	Total length of cord in feet			
		25'	50'	100'	150'
0	6	18'	16'	16'	14'
6	10	18'	16'	14'	12'
10	12	16'	16'	14'	12'
12	16	14'	12'	not recommended	

CAUTION: In all cases make certain the receptacle in question is properly grounded. If you are not sure have a certified electrician, check the receptacle.

ACCESSORIES AND ATTACHMENTS

RECOMMENDED ACCESSORIES

▲ WARNING

- Use only accessories recommended for this miter saw. Follow instructions that accompany accessories. Use of improper accessories may cause hazards.
- The use of any cutting tool except 10 inch saw blades which meet the requirements under recommended accessories is prohibited. Do not use accessories such as shaper cutters or dado sets. Ferrous metal cutting and the use of abrasive wheels is prohibited.
- Do not attempt to modify this tool or create accessories not recommended for use with this tool. Any such alteration or modification is misuse and could result in a hazardous condition leading to possible serious injury.

ACCESSORIES

Visit your Sears Hardware Department or see the Sears Power and Hand Tool Catalog to purchase recommended accessories for this power tool.

▲ WARNING

To avoid the risk of personal injury, do not modify this power tool or use accessories not recommended by Sears.

▲ WARNING

Read warnings and conditions on your **CARBIDE TIPPED SAW BLADE**. Do not operate the saw without the proper saw blade guard in place. Carbide is a very hard but brittle material. Care should be taken while mounting, using, and storing carbide tipped blades to prevent accidental damage. Slight shocks, such as striking the tip while handling, can seriously damage the blade. Foreign objects in the workpiece, such as wire or nails, can also cause tips to crack or break off. Before using, always visually examine the blade and tips for bent blade, cracks, breakage, missing or loose tips, or other damage. Do not use if damage is suspected. Failure to heed safety instructions and warnings can result in serious bodily injury.

TOOLS NEEDED FOR ASSEMBLY

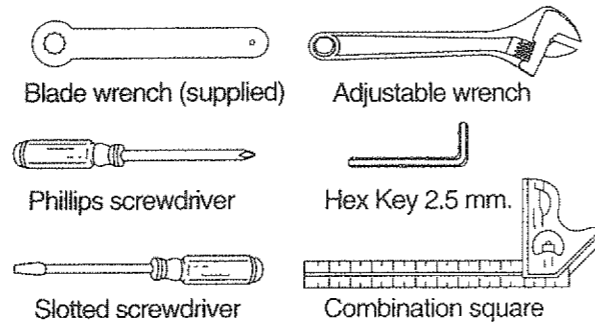

COMBINATION SQUARE MUST BE TRUE

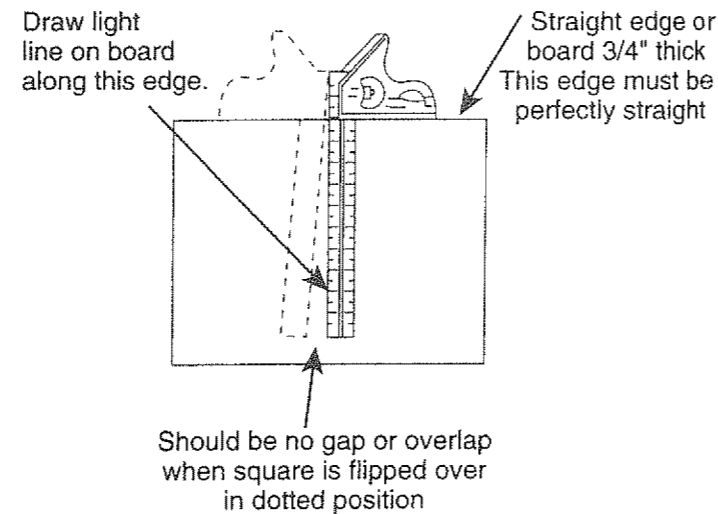

CARTON CONTENTS

UNPACKING YOUR MITER SAW

▲ WARNING

To avoid injury from unexpected starting or electrical shock, do not plug the power cord into a source of power during unpacking and assembly. This cord must remain unplugged whenever you are working on the saw.

1. Remove the miter saw from the carton.
IMPORTANT: Do not lift the miter saw by the switch handle or miter table handle. It may cause misalignment. **ALWAYS LIFT THE MACHINE BY THE BASE HAND HOLDS.**

2. Place the saw on a secure stationary work surface.
3. Separate all parts from the packing material. Check each one with the illustration to make certain all items are accounted for, before discarding any packing material.

▲ WARNING

If any part is missing or damaged, do not attempt to assemble the miter saw, or plug in the power cord until the missing or damaged part is correctly replaced. To avoid electric shock, use only identical replacement parts when servicing double insulated tools.

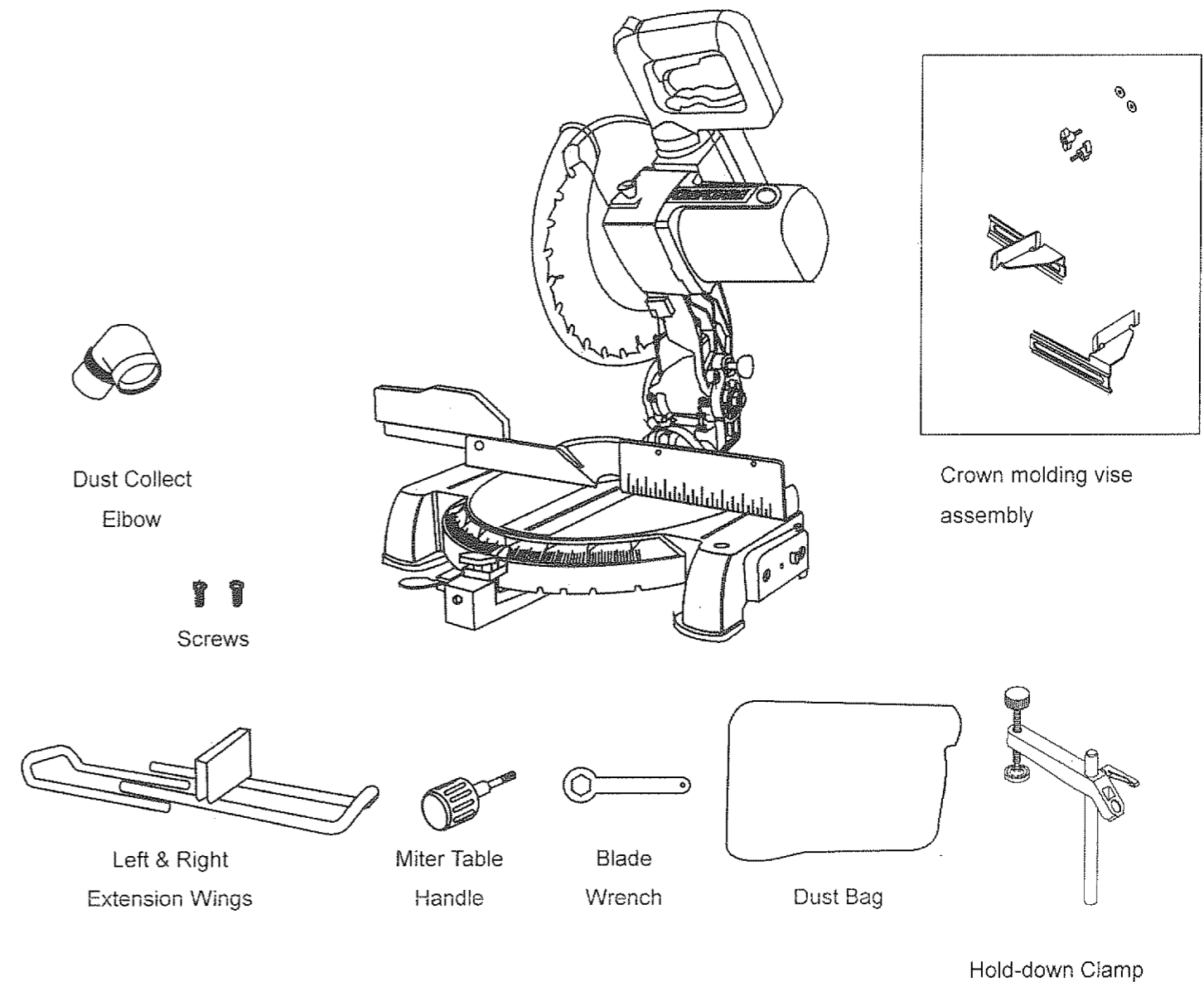

KNOW YOUR COMPOUND MITER SAW

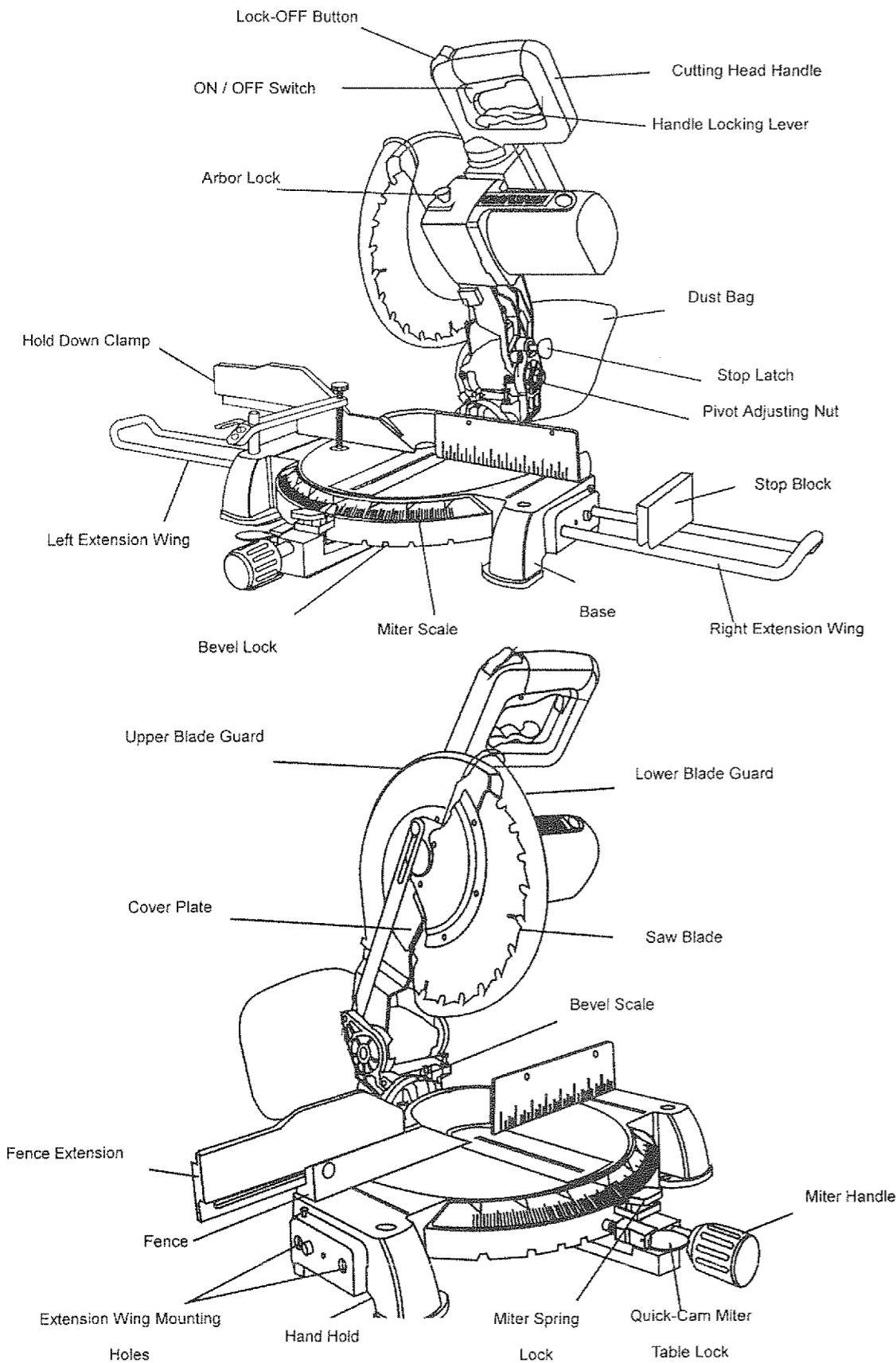

GLOSSARY OF TERMS

CRAFTSMAN COMPOUND MITER SAW TERMS

ARBOR LOCK – Allows the user to keep the blade from rotating while tightening or loosening the arbor screw during blade replacement or removal.

BASE – Supports the table, holds accessories and allows for workbench or leg set mounting.

BEVEL LOCKING HANDLE – Locks the miter saw at a desired bevel angle.

BEVEL SCALE – To measure the bevel angle of the saw blade 0° to 45° left.

COVER PLATE SCREW – Loosen this screw and rotate the plate for access to the blade arbor screw.

DUST CHUTE – Exhausts debris away from the user.

EXTENSION WING – Extend the width of the work table for support while cutting long work pieces. They can be used with or without a stop block as an additional side fence.

FENCE – Helps to keep the workpiece from moving when sawing. Scaled to assist with accurate cutting.

HAND HOLD – For moving the saw when unplugged.

LOCK-OFF SLIDE SWITCH – Must be pushed forward to activate the trigger switch.

LOWER BLADE GUARD – Helps protect your hands from the blade in the raised position, it retracts as the blade is lowered.

MITER HANDLE – Use to lock and unlock the miter table, and to rotate the saw to a right or left cutting position.

MITER SCALE – To measure the miter angle 0° to 45° left, 0° to 45° right.

MITER SPRING LOCK – With the miter handle, locks the miter saw at a preset positive stop for the desired miter angle.

MOUNTING HOLES – To mount the miter saw to a stable surface.

ON/OFF TRIGGER SWITCH – To prevent the trigger from being accidentally engaged, a lock-off slide switch is provided. To start the tool, push the lock-off slide switch forward and squeeze the trigger. Release the trigger to stop the miter saw.

STOP LATCH – Locks the miter saw in the lowered position for compact storage and carrying.

SWITCH HANDLE – The cutting head handle contains the trigger switch and a lock-off slide switch. The blade is lowered into the workpiece by pushing down on the handle. The saw will return to its upright position when the handle is released.

WARNING LABEL – Read for your own safety.

WRENCH STORAGE – Convenient storage to prevent misplacing the blade wrench.

WOODWORKING TERMS

ARBOR – The shaft on which a blade is mounted.

BEVEL CUT – An angle cut made through the face of the workpiece.

COMPOUND CUT – A simultaneous bevel and miter cut.

CROSS CUT – A cut made across the width of the workpiece.

FREEHAND – Performing a cut without using a fence (guide), hold down or other proper device to prevent the workpiece from twisting during the cutting operation.

GUM – A sticky sap from wood products.

HEEL – Misalignment of the blade.

KERF – The amount of material removed by blade cut.

MITER CUT – An angle cut made across the width of the workpiece.

RESIN – A sticky sap that has hardened.

REVOLUTIONS PER MINUTE (RPM) – The number of turns completed by a spinning object in one minute.

SAW BLADE PATH – The area of the workpiece or table top directly in line with the travel of the blade or the part of the workpiece which will be cut.

SET – The distance between two saw blade tips, bent outward in opposite directions to each other. The further apart the tips are, the greater the set.

WORKPIECE – The item being cut. The surfaces of a workpiece are commonly referred to as faces, ends, and edges.

ASSEMBLY AND ADJUSTMENTS

ASSEMBLY INSTRUCTIONS

▲ WARNING

To avoid injury, do not connect this miter saw to the power source until it is completely assembled and adjusted, and you have read and understood this Operator's Manual.

INSTALLING THE MITER HANDLE (FIG. A)

1. Thread the miter handle (1) into the hole (2) located at the front of the miter table.

Fig. A

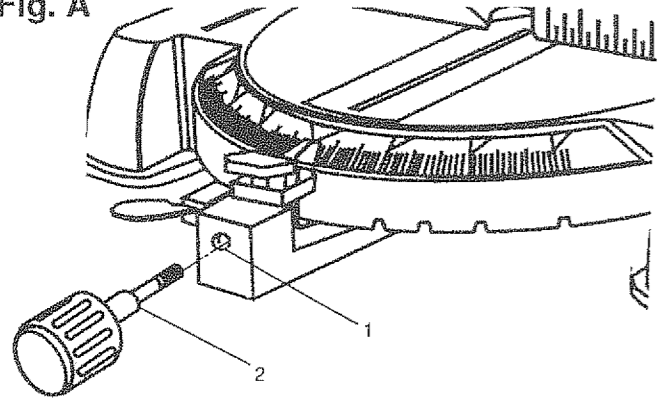

SAW BLADE WRENCH (FIG. B)

1. For convenient storage and prevention of loss, there is a slot (1) in the rear of the cutting head handle (2) for storing the blade wrench (3) when not in use.

Fig. B

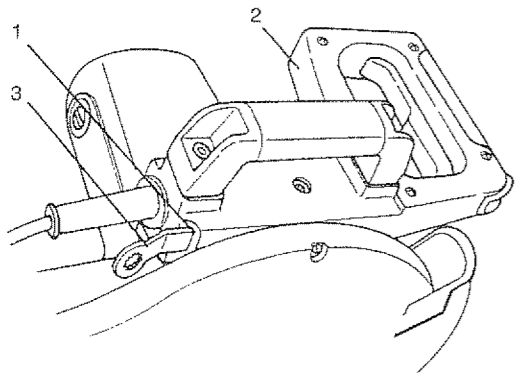

CUTTING HEAD (FIG. C)

Raising

1. Push down slightly on the cutting handle (1).
2. Pull out the stop latch knob (2).
3. Allow the cutting head (3) to raise to the up position.

▲ WARNING

To avoid injury and damage to the saw, transport or store the miter saw with the cutting head locked in the down position. Never use the stop latch to hold the cutting head in a down position for cutting operations.

Fig. C

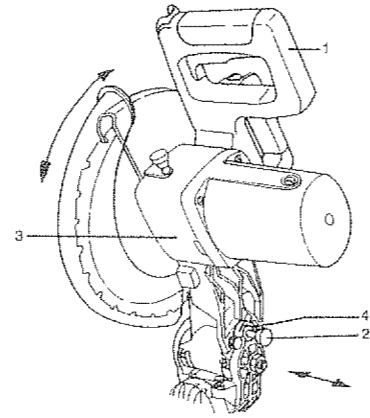

Locking

When transporting or storing the miter saw, the cutting head should always be locked in the down position.

1. Push the cutting head (3) down to its lowest position.
2. Push the stop latch (2) into the locking hole (4).

IMPORTANT: To avoid damage, never carry the miter saw by the switch handle, the cutting arm, or the miter table handle. ALWAYS use the hand holds in the base, or the designated carrying handle.

THE DUST COLLECTION SYSTEM (FIG. D, D-1)

INSTALLING THE DUST COLLECTION ELBOW (FIG. D)

1. Install the larger end of the elbow (1) onto the exhaust port (2).

NOTE: The elbow can be used to attach either the dust bag or a vacuum hose to remove sawdust from the work area.

Fig. D

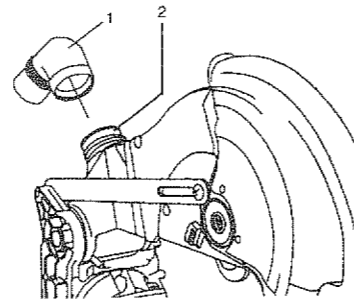

INSTALLING THE DUST BAG (FIG. D-1)

1. Squeeze the metal collar wings (1) of the dust bag (2).
2. Place the dust bag neck opening around the exhaust port (3), and release the metal collar wings.

Fig. D-1

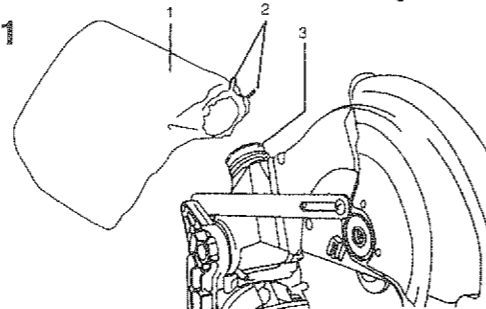

ASSEMBLY AND ADJUSTMENTS

INSTALLING EXTENSION WINGS (FIG. E)

▲ WARNING

To avoid injury or possible damage to the tool, support long work pieces by installing the extension wings to extend the work support surface.

The extension wings are provided with an end stop bracket. The extension may be used with or without the end stop.

To install the end stop bracket:

1. Slide the end stop (1) onto the rail (2) of the one extension wing. Place at the desired location.
2. Thread the wing bolt (4) into the bracket and tighten.
3. Place the rods into the holes (5) provided in the miter saw base.
4. Insert Phillips screw (6) into tab hole (7) and tighten to hold the extension rod.

To install without the end stop bracket:

5. Loosen the wing nut and slide the end stop bracket off the extension wing rods.
6. Install the rods into the saw base holes.
7. Insert the Phillips screw into the tab hole and tighten.

Fig. E

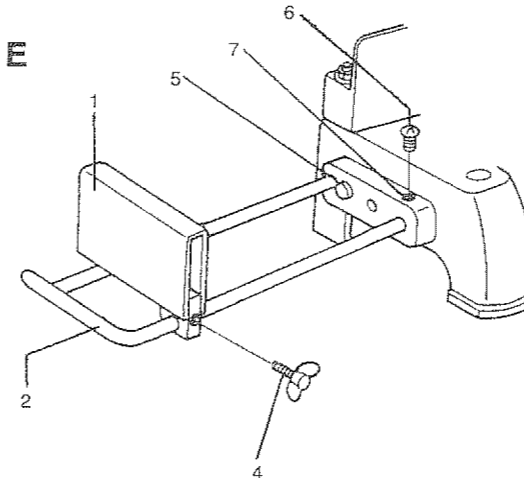

REMOVING OR INSTALLING THE BLADE

▲ WARNING

1. Only use a 10-inch diameter blade.
2. To avoid injury from an accidental start, make sure the switch is in the OFF position and the plug is not connected to the power source outlet.

REMOVING (FIG. F, G, H)

▲ WARNING

1. Unplug the saw from the outlet.
2. Allow the miter saw to rise to the upright position. Raise the lower blade guard (1) to the up position. (Fig. F)

3. Loosen the cover plate screw (2) with a Phillips screwdriver.
4. Rotate the cover plate (3) to expose the arbor screw (4).
5. Place the blade end wrench over the arbor screw.

Fig. F

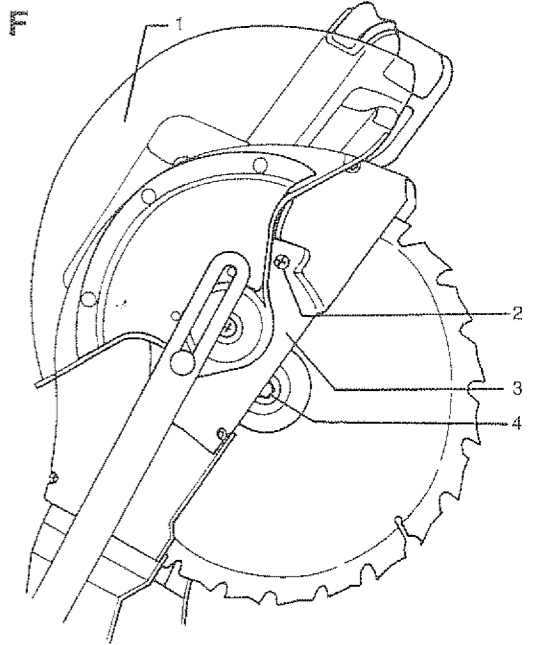

6. Locate the arbor lock (5) on the motor, below the miter saw switch handle. (Fig. G)
7. Press the arbor lock, holding it in firmly while turning the blade wrench clockwise. The arbor lock will engage after turning the wrench. Continue to hold the arbor locking to keep it engaged, while turning the wrench clockwise to loosen the arbor screw.

Fig. G

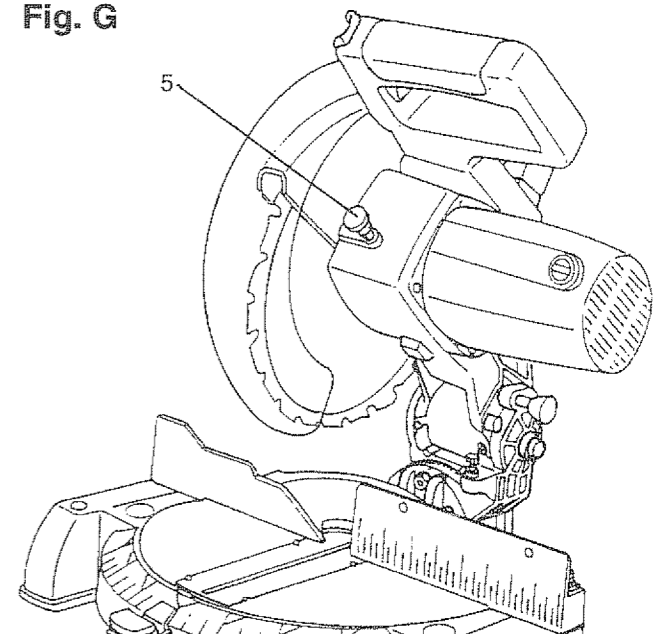

REMOVING – cont'd

8. Remove the arbor screw and washer (4), outer blade collar (6), and the blade (7). Do not remove the inner blade collar. (Fig. H)

NOTE: Pay attention to the pieces removed, noting their position and direction they face. Wipe the blade collars clean of any sawdust before installing the new blade.

Fig. H

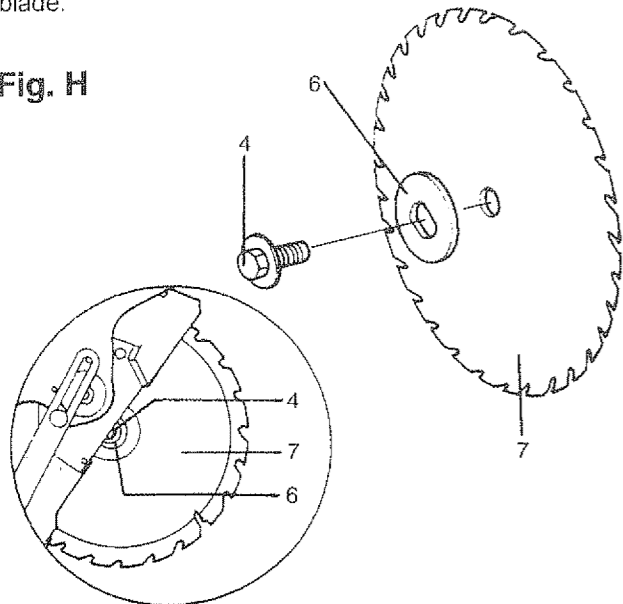

INSTALLING BLADE (FIG. F, G, H)

1. Install a 10" blade, making sure the rotation arrow on the blade matches the clockwise rotation arrow on the upper guard, and the blade teeth are pointing downward.
2. Place the outer blade collar (6) on the blade and on the arbor. Thread the arbor screw (4) into the arbor. (Fig. H)

IMPORTANT: make sure the flats of the blade collars are engaged with the flats on the arbor shaft.

3. Place the blade wrench on the arbor screw.
4. Press the arbor lock (5), holding it in firmly while turning the blade wrench counterclockwise. When it engages, continue to press the arbor lock in, while tightening the arbor screw securely. (Fig. G)
5. Rotate the cover plate (3) back until the slot in the cover plate engages with the cover plate screw (2). Tighten the screw with a Phillips screwdriver.
6. Lower the blade guard (1). (Fig. F)
7. Be sure the arbor lock is released so the blade turns freely.

WARNING

- To avoid injury, never use the saw without the cover plate secure in place. It keeps the arbor screw from falling out if it accidentally loosens, and helps prevent the spinning blade from coming off the saw.
- Make sure the collars are clean and properly arranged. Lower the blade into the lower table and check for any contact with the metal base or the turn table.

INSTALLING THE CROWN MOLDING HOLD-DOWN CLAMP (Optional) (FIG. H-1)

Place the crown molding Hold-down Clamp (1) on the desired clamp hole (2). If the crown molding Hold-down Clamp to be used as a normal clamp:

1. Loosen and remove lock handle (3) and rod. Install the lock handle and rod (4) onto the other hole (5) of clamp arm (6).
2. Tighten the lock handle.

NOTE: When bevel angles are 31.6° and 33.9°, place the crown molding Hold-down Clamp (1) on the desired clamp hole (7)

Fig. H-1

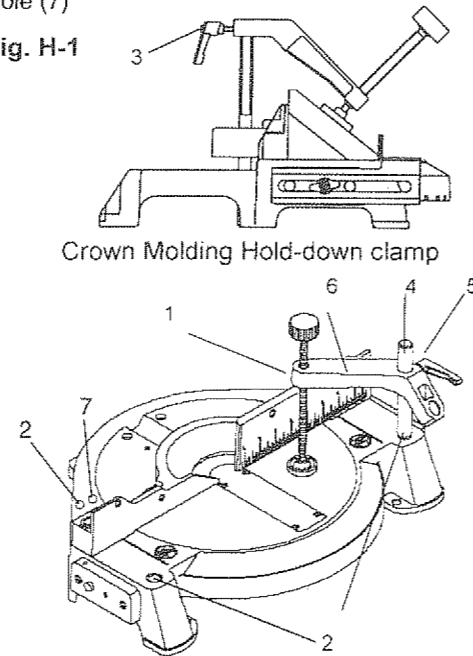

INSTALL CROWN MOLDING VISE ASSEMBLY (OPTIONAL USE) (FIG. H-2)

WARNING

To avoid injury or possible damage to the tool, clamp moldings by installing the crown molding vise assembly to secure the moldings.

1. Place the plate (1) into the flange (2) provided in the miter saw base.
2. Place the flat washer (3) on the knob (4). Thread the knob (4) into the tab hole (5) and tighten the knob.
3. The Fig. H-2 only shows the installation of the right crown molding vise. Repeat these procedures for the left crown molding vise.

Fig. H-2

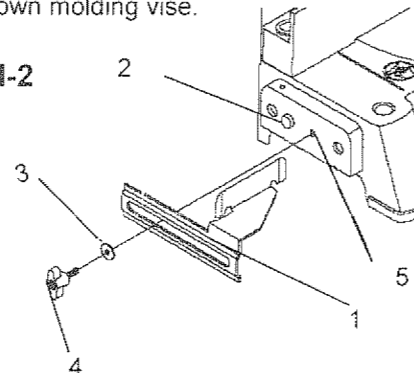

ADJUSTMENTS

WARNING

To avoid injury from an accidental start, make sure the switch is in the OFF position and the plug is not connected to the power source outlet.

ADJUSTING FENCE SQUARENESS (FIG. I)

1. Loosen the four fence locking screws (1).
2. Using a square, lay the heel of the square against the blade, and the rule against the fence (2) as shown. Check to see if the fence is 90° to the blade.
3. Adjust the fence to be 90° to the blade and tighten the two fence locking screws.

CAUTION: If the saw has not been used recently, recheck blade squareness to the fence and readjust if needed.

Fig. I

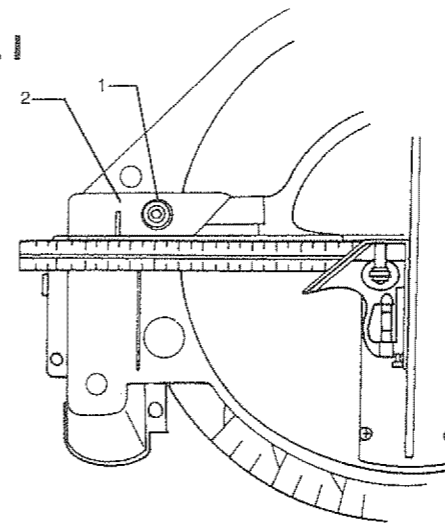

MITER SCALE (FIG. J)

The miter scale on the table has nine of the most common angle settings with positive stops at 0°, 15°, 22.5°, 31.6° and 45° left and right. These positive stops position the blade at the desired angle quickly and accurately.

Positive Stop Miter Angle Adjustment:

1. Unlock the miter table by pressing down on the positive stop locking lever (1).
2. While holding the positive stop locking lever down, grasp the miter handle (2) and move the miter table left or right to the desired angle.
3. Release the positive stop locking lever, making sure it engages with the positive stop. Slight movement of the miter handle will ensure positive stop engagement.

Miter Angle Pointer Adjustment:

1. Place the miter table at the zero position.
2. Loosen the miter angle indicator screw (3) and adjust the indicator to the "0" mark on the miter scale.
3. Tighten miter angle indicator screw.

Quick-Cam Miter Table Lock Operation:

If miter angles required are NOT one of the nine positive stops noted above, the miter table can be locked at any angle between these positive stops by using the Quick-Cam table lock.

1. Unlock the miter table by pressing down on the positive stop locking lever (1).
2. While holding the positive stop locking lever down, grasp the miter handle (2) and move the miter table left or right to the desired angle.
3. Release the positive stop locking lever.
4. Press down on the Quick-Cam locking lever (4) until it locks the miter table in place.

NOTE: Quick-Cam locking lever should lock the table and prevent it from moving. If adjustment is needed, adjust as required.

Quick-Cam Miter Table Lock Adjustment:

1. Release Quick-Cam locking lever (4).
2. Loosen Quick-Cam lock nut (5) using a 13 mm wrench.
3. Turn adjusting screw (6) either in or out until locking lever firmly locks the miter table in place.
4. Tighten Quick-Cam locking nut.

Fig. J

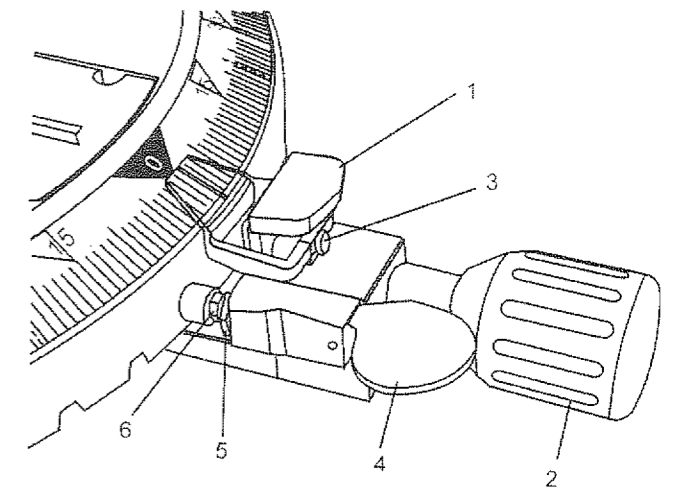

CUTTING ARM TRAVEL (FIG. K)

Cutting arm pivot adjustment

The up and down pivot movement of the cutting arm should be free of side-to-side movement for accurate miter cuts. It should be tight enough to prevent side-to-side movement while still allowing the arm to move freely up and down when cutting.

1. Before attempting this adjustment, move the sliding fence as far to the LEFT as possible (See SLIDING FENCE on page 19).
2. If cutting arm (1) is too loose, turn the cutting arm adjusting nut (2) clockwise using a 19 mm wrench.
3. If cutting arm is too tight, turn the cutting arm adjusting nut counter clockwise.

Fig.K

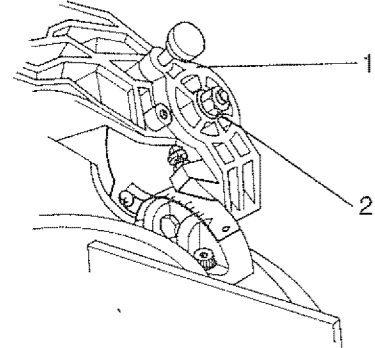

Cutting head downward travel adjustment (FIG. L)

Before each cutting operation, check the position of the blade to make sure it does not contact any metal surface. If it contacts any metal surface, the depth of movement can be adjusted.

⚠ WARNING

To avoid injury from unexpected starting or electrical shock, turn the switch OFF and remove the power cord from the power source.

1. Before attempting this adjustment, move the sliding fence as far to the LEFT as possible (see SLIDING FENCE on page 19).
2. Lower the blade as far as possible.
3. Loosen lock nut (3) using a 10 mm wrench.
4. Turn the adjusting screw (4) IN to lower the maximum cutting depth and OUT to raise the maximum cutting depth.
5. Lower the blade to the new maximum depth and rotate the blade by hand to make sure it does not contact any metal.
NOTE: Repeat adjustment and checking until blade no longer contacts any metal.
6. Tighten lock nut.

Cutting head downward travel adjustment – Cont'd

Fig.L

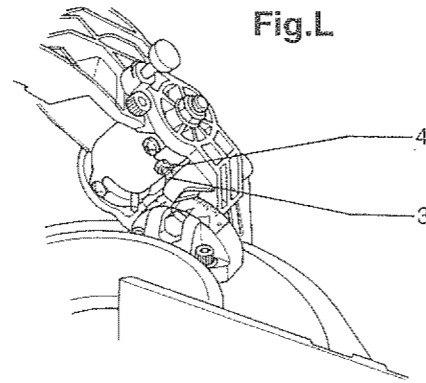

BEVEL STOP ADJUSTMENT (FIG. M & N)

Before each cutting operation, check the position of the blade to make sure it does not contact any metal surface. If it contacts any metal surface, the depth of movement can be adjusted.

⚠ WARNING

To avoid injury from unexpected starting or electrical shock, turn the switch OFF and remove the power cord from the power source.

90° Bevel adjustment (Fig. M)

1. Loosen bevel lock handle (1) and tilt the cutting arm completely to the left. Tighten the bevel lock handle.
2. Place a combination square (2) on the miter table with the rule against the table and the heel of the square against the saw blade.
3. If the blade is not square with the miter table, turn the bevel angle adjusting screw (3) in or out with a wrench from underneath the table until the blade is square with the table.
4. Tighten bevel lock handle.

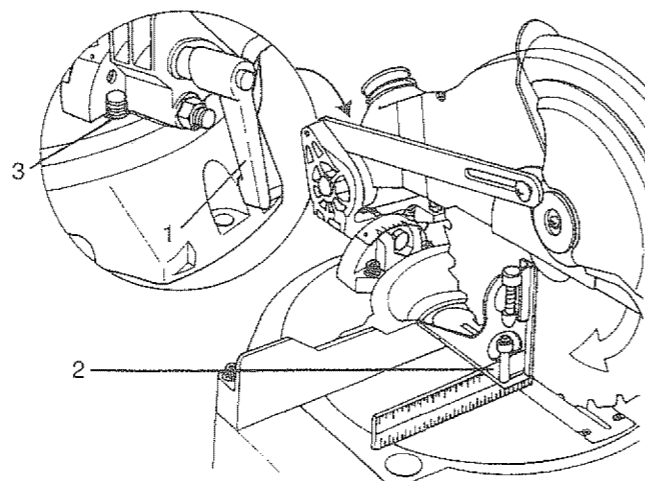

Fig.M

BEVEL STOP ADJUSTMENT (FIG. M & N) – Cont'd

90° Bevel indicator (Fig. N)

5. When the blade is exactly 90° to the table loosen the LEFT bevel indicator screw (5) using a #2 Phillips screwdriver.
6. Adjust LEFT bevel indicator (6) to the "0" mark (7) on the bevel scale and retighten the screw.

45° Bevel adjustment

7. Unlock the bevel lock handle and tilt the cutting arm as far to the left as possible.
8. Using a combination square, check to see if the blade angle is 45° to the table.
9. If the blade is not at 45° to the miter table, turn the bevel angle adjusting screw (4) in or out with a wrench from underneath the table until the blade is at 45° to the miter table.
10. Tighten bevel lock handle.

45° Bevel indicator (Fig. N)

11. When the blade is exactly 45° to the table, loosen the RIGHT bevel indicator screw (8) using a #2 Phillips screwdriver.
12. Adjust RIGHT bevel indicator (9) to the 45° mark (10) on the bevel scale and retighten the screw.

Fig.N

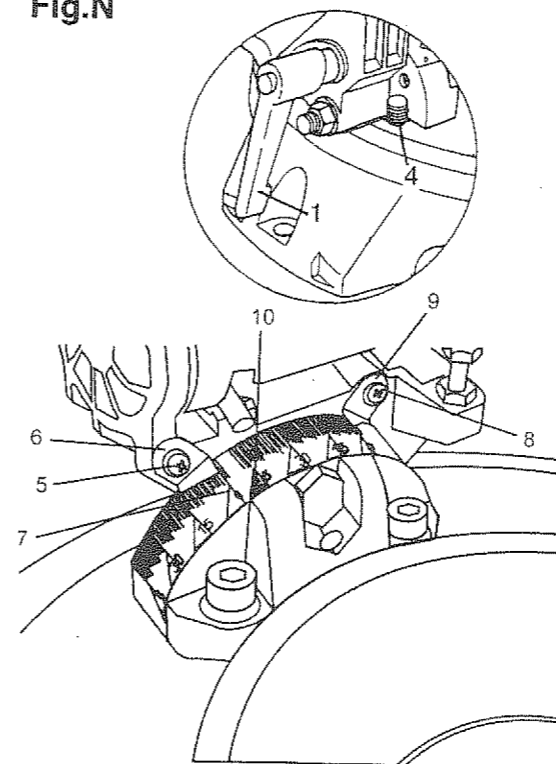

MOUNTING THE MITER SAW (FIG. O)

To avoid injury from unexpected saw movement:

- Before moving the saw, disconnect the power cord from the outlet, and lock the cutting arm in the lower position using the stop latch.

NOTE: The stop latch is for carrying or storing the tool. It is NOT to be used holding the saw while cutting.

- Never carry the miter saw by the power cord or by the switch handle. Carrying the tool by the power cord could cause damage to the insulation or wire connections resulting in electric shock or fire.
- To avoid injury from flying debris, do not allow visitors to stand behind the saw.
- Place the saw on a firm, level work-surface where there is room for handling and proper support of the workpiece.
- Support the saw on a level work surface.
- Bolt or clamp the saw to its support.

Place the saw in the desired location, either on a work bench or recommended leg set. The base of the saw has three mounting holes (1).

For stationary use, fasten the saw to a workbench.

For portable use, fasten the saw to a 3/4" piece of plywood. This mounting board can then be clamped to a secure surface.

Fig.O

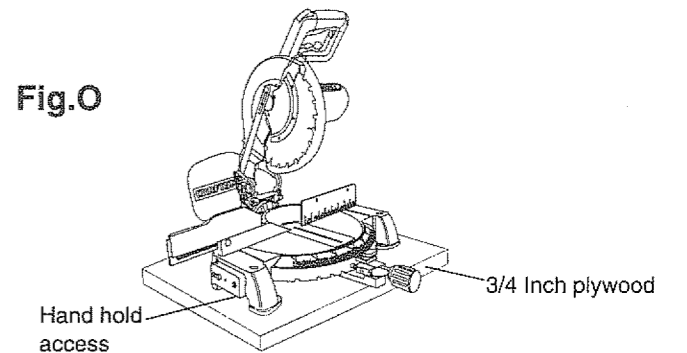

Stationary use (1)

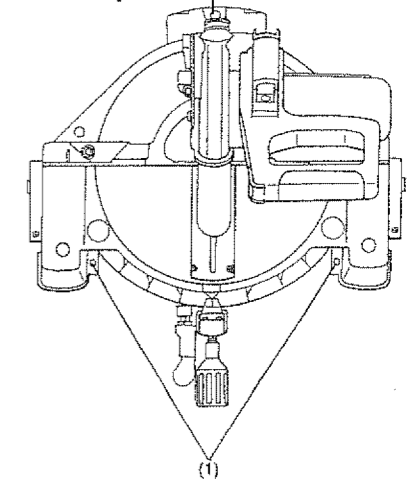

OPERATION

SAFETY INSTRUCTIONS FOR BASIC SAW OPERATION

BEFORE USING THE MITER SAW

▲ WARNING

To avoid mistakes that could cause serious, permanent injury, do not plug the tool in until the following steps are completed:

- Completely assemble and adjust saw, following the instructions. **(ASSEMBLY AND ADJUSTMENTS)**
- Learn the use and function of the ON/OFF switch, lock-off switch, upper and lower blade guards, stop latch, bevel lock handle, and cover plate screws.
- Review and understand all safety instructions and operating procedures in this Operator's Manual. **(SAFETY & OPERATIONS)**
- Review the MAINTENANCE and TROUBLESHOOTING GUIDE for your miter saw.
- To avoid injury or possible death from electrical shock: Make sure your fingers do not touch the plug's metal prongs when plugging or unplugging your miter saw. **(ELECTRICAL REQUIREMENTS AND SAFETY)**

BEFORE EACH USE

Inspect your saw.

- **Disconnect the miter saw.** To avoid injury from accidental starting, unplug the saw before any adjustments, including set-up and blade changes.
- **Compare the direction of rotation arrow** on the guard to the direction arrow on the blade. The blade teeth should always point downward at the front of the saw.
- **Tighten the arbor screw.**
- **Tighten the cover plate screw.**
- **Check for damaged parts.** Check for:
 - Alignment of moving parts
 - Damaged electric cords
 - Binding of moving parts
 - Mounting holes
 - Function of arm return spring and lower guard:
Push the cutting arm all the way down, then let it rise until it stops. The lower guard should fully close. Follow instructions in TROUBLESHOOTING GUIDE for adjustment.
 - Other conditions that may affect the way the miter saw works.

- Keep all guards in place, in working order and proper adjustment.
NOTE: If any part of this miter saw is missing, bent, damaged or broken in any way, or any electrical parts don't work, turn the saw off and unplug it. Replace damaged, missing, or defective parts before using the saw again.

- Maintain tools with care. Keep the miter saw clean for best and safest performance. Follow instructions for lubricating. Don't put lubricants on the blade while it's spinning.

- Remove adjusting wrench from the tool before turning it on.

- To avoid injury from jams, slips, or thrown pieces:

USE ONLY RECOMMENDED ACCESSORIES

- Consult the ACCESSORIES and ATTACHMENTS section of this Operator's Manual for recommended accessories. Follow the instructions that come with the accessory. The use of improper accessories may cause serious injury.
- Choose the correct 10 inch diameter blade for the material and the type of cutting you plan to do.
- Make sure the blade is sharp, undamaged and properly aligned. With the saw unplugged, push the cutting arm all the way down. Hand spin the blade and check for clearance. Tilt the power-head to a 45° bevel and repeat the check.
- Make sure the blade and arbor collars are clean.
- Make sure all clamps and locks are tight and there is no excessive play in any parts.

KEEP YOUR WORK AREA CLEAN

Cluttered areas and benches invite accidents.

▲ WARNING

To avoid burns or other fire damage, never use the miter saw near flammable liquids, vapors, or gases.

- Plan ahead to protect your eyes, hands, face and ears.
- Know your miter saw.
Read and understand the Operator's Manual and labels affixed to the tool. Learn its application and limitations as well as the specific potential hazards peculiar to this tool. To avoid injury from accidental contact with moving parts, don't do layout, assembly, or setup work on the miter saw while any parts are moving.
- Avoid accidental starting
Make sure the switch is OFF before plugging the miter saw into a power outlet.

PLAN YOUR WORK

- Use the right tool. Don't force a tool or attachment to do a job it was not designed to do. Use a different tool for any workpiece that can't be held in a solidly braced, fixed position.

CAUTION: This machine is not designed for cutting ferrous metals (steel, iron, and iron-based metals.) Use this miter saw to cut only wood, wood-like products, or soft metals like aluminum. Other material may shatter, bind the blade, or create other dangers. Remove all nails that may be in the workpiece to prevent sparking that could cause a fire.

DRESS FOR SAFETY

Any power tool can throw foreign objects into the eyes. This can result in permanent eye damage. Everyday eyeglasses have only impact resistant lenses and are not safety glasses. Glasses or goggles not in compliance with ANSI Z87.1 could cause serious injury when they break.

- Do not wear loose clothing, gloves, neckties or jewelry (rings, watches). They can get caught and draw you into moving parts.
- Wear non-slip footwear.
- Tie back long hair.
- Roll long sleeves above the elbow.
- Noise levels vary widely. To avoid possible hearing damage, wear ear plugs when using any miter saw.
- For dusty operations, wear a dust mask along with safety goggles.

INSPECT YOUR WORKPIECE

Make sure there are no nails or foreign objects in the part of the workpiece being cut.

Plan your work to avoid small pieces that may bind, or that are too small to clamp and get a solid grasp on.

Plan the way you will grasp the workpiece from start to finish. Avoid awkward operations and hand positions. A sudden slip could cause your fingers or hand to move into the blade.

DON'T OVER-REACH

Keep good footing and balance. Keep your face and body to one side, out of the line of a possible kickback. NEVER stand in the line of the blade.

Never cut freehand:

- Brace your workpiece firmly against the fence and table stop so it will not rock or twist during the cut.
- Make sure there is no debris between the workpiece and the table or fence.

- Make sure there are no gaps between the workpiece, fence and table that will let the workpiece shift after it is cut.
- Keep the cut off piece free to move sideways after it is cut off. Otherwise, it could get wedged against the blade and thrown violently.
- Only the workpiece should be on the saw table.
- Secure work. Use clamps or a vise to help hold the work when it's practical.

USE EXTRA CAUTION WITH LARGE OR ODD SHAPED WORKPIECES.

- Use extra supports (tables, sawhorses, blocks, etc.) for workpieces large enough to tip.
- Never use another person as a substitute for a table extension, or as an additional support for a workpiece that is longer or wider than the basic miter saw table, or to help feed, support, or pull the workpiece.
- Do not use this saw to cut small pieces. If the workpiece being cut would cause your hand or fingers to be within 6-1/2 inches of the saw blade the workpiece is too small. Keep hands and fingers out of the "no hands zone" area marked on the saw table.
- When cutting odd shaped workpieces, plan your work so it will not bind in the blade and cause possible injury. Molding, for example, must lie flat or be held by a fixture or jig that will not let it move when cut.
- Properly support round material such as dowel rods, or tubing, which have a tendency to roll when cut, causing the blade to "bite".

WHEN SAW IS RUNNING

▲ WARNING

Don't allow familiarity from frequent use of your miter saw to result in a careless mistake. A careless fraction of a second is enough to cause a severe injury.

Before cutting, if the saw makes an unfamiliar noise or vibrates, stop immediately. Turn the saw OFF. Unplug the saw. Do not restart until finding and correcting the problem.

BODY AND HAND POSITION (FIG. O-1)

Proper positioning of your body and hands when operating the miter saw will make cutting easier and safer. Never place hands near the cutting area. Place hand at least 6-1/2" away from the path of the blade. Hold workpiece firmly against the fence to prevent movement toward the blade. Keep hands in position until the trigger has been released and the blade has completely stopped. Before making a cut, with the power switch in the OFF position bring the saw blade down to the workpiece to see the cutting path of the blade.

- Keep children away. Keep all visitors a safe distance from the miter saw. Make sure bystanders are clear of the miter saw and workpiece.
- Don't force tool. It will do the job better and safer at its designed rate. Feed the saw into the workpiece slowly with a firm downward motion.
- Before freeing jammed material:
 - Turn switch OFF.
 - Unplug the miter saw.
 - Wait for all moving parts to stop.
- After finishing a cut.
 - Keep holding the power head down.
 - Release the switch, and wait for all moving parts to stop before moving your hands.
 - If the blade doesn't stop within 6 seconds, unplug the saw and follow the instructions in TROUBLESHOOTING GUIDE section for adjusting the blade brake before using the saw again.

Fig.O-1

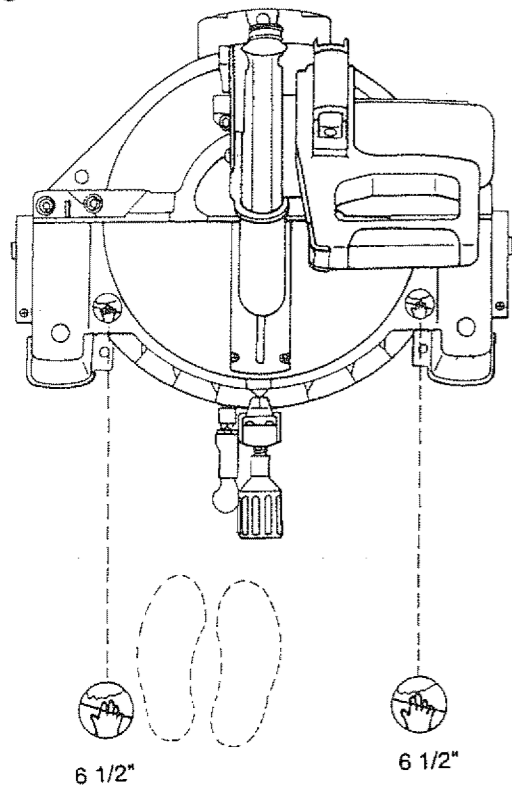

TURNING SAW ON (FIG. P)

To reduce the likelihood of accidental starting, a thumb activated lock-OFF switch is located on top of the switch handle. The lock-OFF switch (1) must be pushed forward before the trigger switch (2) can be activated and the miter saw started.

⚠ WARNING

Make the switch child-proof. Insert a padlock through the hole (3) in the trigger switch and lock it. This will prevent children and other unauthorized users from turning the switch ON.

ROTATING HANDLE (FIG. P)

The handle of the miter saw has been designed to rotate 45° or 90° for operator convenience. To rotate the handle:

1. Unlock the handle locking lever (4) by pulling it toward you.
2. Pull the handle locking latch (5) toward you with your thumb.
3. Rotate the handle 45° or 90° and release the handle locking latch.
4. Lock the handle locking lever by pushing it IN toward the back of the handle.

NOTE: After releasing the handle locking latch, rotate the handle left and right to make sure the latch engages into the positive locking position.

- NOTE:** The tightness of handle can be adjusted by following step:
1. Loosen the four screws (6), and remove the handle seat (7).
 2. If rotating handle (8) is too loose or tight, adjusting nut (9) clockwise or counter clockwise.

Fig.P

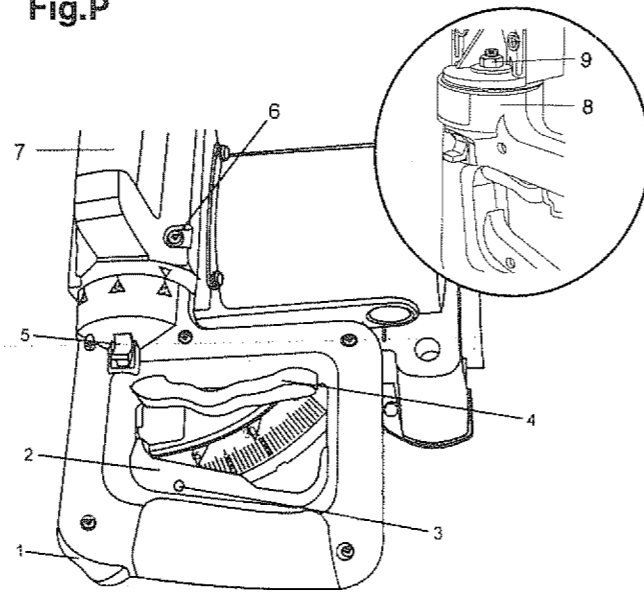

SLIDING FENCE (FIG. Q-1)

⚠ WARNING

The sliding fence must be fully extended to the left when making any miter or bevel cuts other than 0°. Failure to fully extend the sliding fence will not allow enough space for your hand which could result in serious injury. At extreme miter or bevel angles the saw blade may also contact the fence.

1. Unlock the fence cam locking lever (1) by pulling it out from the back of the fence.
2. Fully extend the fence by sliding it out as far as possible (2).
3. Lock the fence cam lock by pushing it IN toward the rear of the fence.

NOTE: When transporting the saw, always secure the sliding fence in the collapsed position (toward the saw blade).

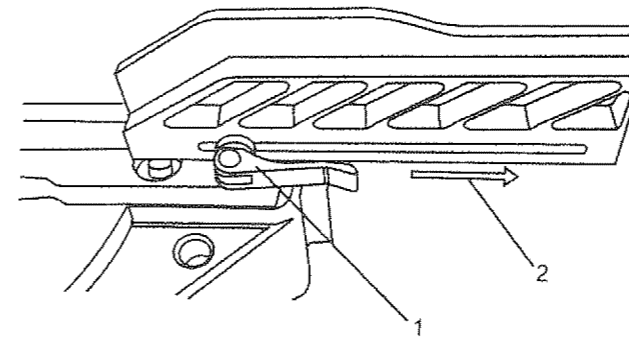

Fig.Q-1

MITER CUT (FIG. R)

1. Unlock the miter table by pressing down on the positive stop locking lever (2).
2. While holding the positive stop locking lever down, grasp the miter handle (1) and move the miter table left or right to the desired angle.
3. Release the positive stop locking lever, making sure it engages the positive stop. Slight movement of the miter handle left or right will ensure positive stop engagement.

NOTE: Positive stops are provided at 0°, 15°, 22.5°, 31.6° and 45° left and right.

NOTE: If miter angle required is NOT one of the positive stops noted above, the miter table can be locked at any angle between these positive stops by using the Quick-Cam table lock (see Page 13).

Fig.R

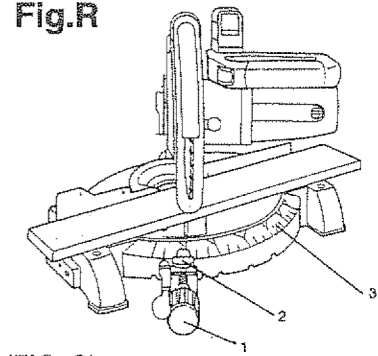

BEVEL CUT (FIG. S)

When a bevel cut is required, loosen the bevel lock handle (1). Tilt the cutting head to the desired angle as shown on the bevel scale (2). The blade can be positioned at any angle, from a 90° straight cut (0° on the scale) to a 45° left bevel. Tighten the lock handle (1) to lock the cutting head in position. Positive stops are provided at 0 and 45°.

Fig.S

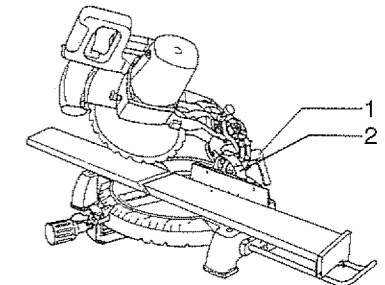

COMPOUND CUT (FIG. T)

⚠ WARNING

The sliding fence must be fully extended to the left when making any compound cuts. Failure to fully extend the sliding fence will not allow enough space for your hand which could result in serious injury. At extreme compound angles the saw blade may also contact the fence.

1. Fully extend the fence by sliding it out as far as possible. See SLIDING FENCE on this page.
2. Set the desired bevel angle using bevel lock handle (1). See BEVEL CUT on this page.
3. Set the desired miter angle using positive stop locking lever (3) or Quick-Cam table lock. See MITER CUT on this page.

Fig.T

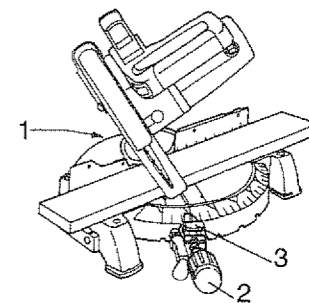

CUTTING BOWED MATERIAL (FIG. U)

A bowed workpiece must be positioned and cut. Do not position workpiece incorrectly or try to cut the workpiece without the support of the fence. This will cause the blade to bind and could result in personal injury.

Fig.U

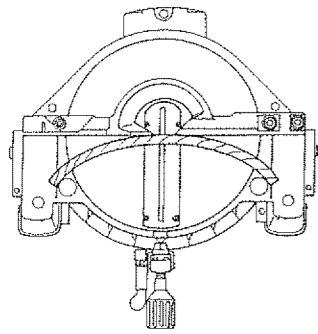

WORKPIECE SUPPORT (FIG. V)

Long pieces need extra support. The support should be placed under the workpiece. Keep your hand holding the workpiece positioned 6-1/2" or more away from the blade. The support must let the workpiece lay flat on the work table during the cutting operation.

NOTE: When mounted on a flat surface, the miter saw table is 3-13/16 inches high.

Fig.V

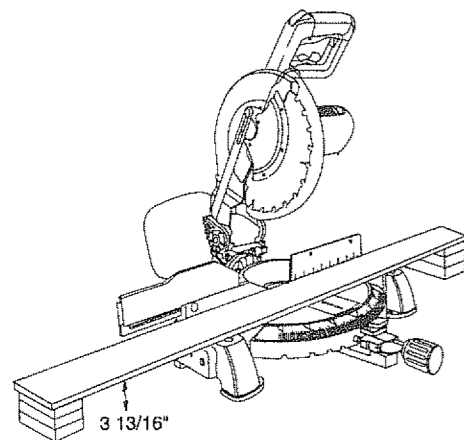
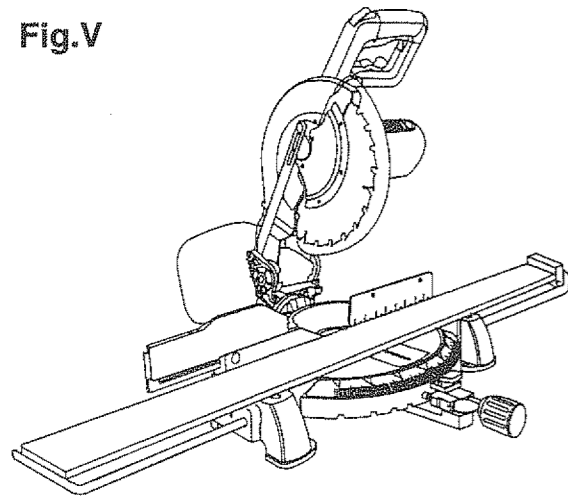

AUXILIARY WOOD FENCE (FIG. W)

When making multiple or repetitive cuts that result in cut-off pieces of one inch or less, it is possible for the saw blade to catch the cut-off piece and throw it out of the saw or into the blade guard and housing, possibly causing damage or injury. To minimize this, an auxiliary wood fence can be mounted to your saw. Holes are provided in the saw fence to attach an auxiliary wood fence. This fence is constructed of straight auxiliary wood approximately 3/4 inch thick by 3 inches high by 19-1/2 inches long. Attach the wood fence securely and make a full depth cut to make a blade slot.

Check for interference between the wood fence and the lower blade guard. Adjust if necessary.

NOTE: This auxiliary fence is used only with the saw blade in the 0° bevel position (90° to the table). The auxiliary wood fence must be removed when bevel cutting.

Fig.W

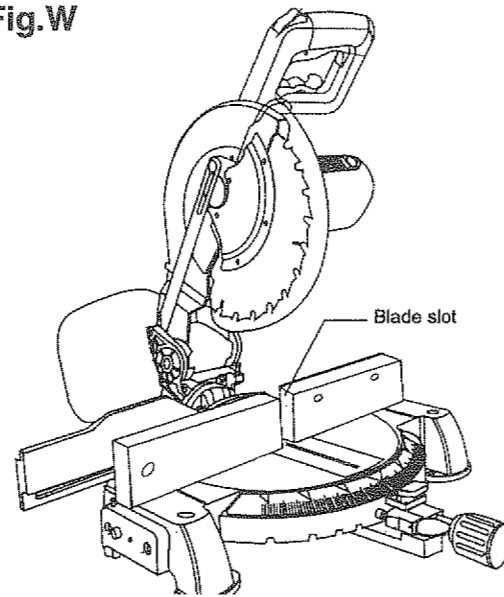

Cutting capacity with auxiliary fence	
Crosscut	3-1/2" x 3-1/2"
Miter 45° R. & L.	3-1/2" x 2"
Bevel 45° L.	2" x 3-1/2"
Compound 45° L., 45° R & L.	2" x 2"

CUTTING A DIMENSIONAL 4X4 WITH ONE CUT (FIG. X)

A dimensional 4x4-in may be cut in half with one cut by attaching an auxiliary wood fence of 3/4 inch thick. See **AUXILIARY WOOD FENCE** above.

Fig.X

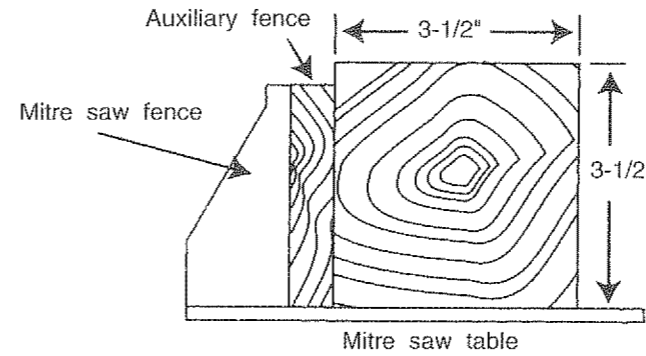

VERTICAL MITER CUTTING (FIG. Y)

To make a miter cut in a 2x4 workpiece (1-5/8" x 3-1/2") in the vertical position on edge a spacer such as the auxiliary wood fence described in the **AUXILIARY WOOD FENCE** section is required.

Fig.Y

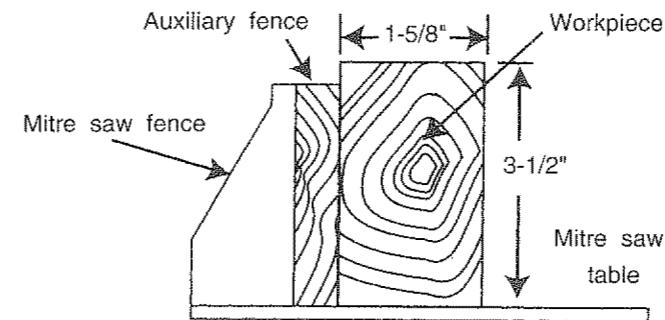

CUTTING BASE MOLDING (FIG. Z)

Base moldings and many other moldings can be cut on a compound miter saw. The setup of the saw depends on molding characteristics and application, as shown. Perform practice cuts on scrap material to achieve best results:

1. Always make sure moldings rest firmly against fence and table. Use hold-down or C-clamps, whenever possible, and place tape on the area being clamped to avoid marks.
2. Reduce splintering by taping the cut area prior to making cut. Mark cut line directly on the tape.
3. Splintering typically happens due to wrong blade application and thinness of the material.

Fig.Z

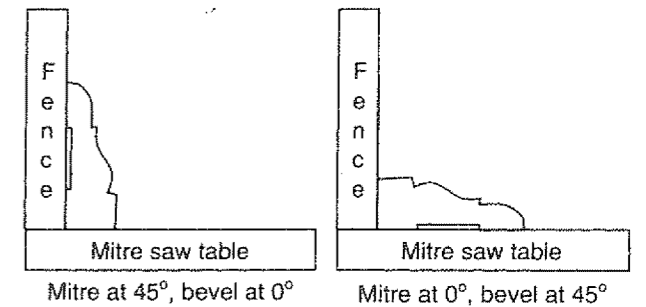

NOTE: Always perform a dry run cut so you can determine if the operation being attempted is possible before power is applied to the saw.

CUTTING CROWN MOLDING (FIG. AA, BB, CC)

Your compound miter saw is suited for the difficult task of cutting crown molding. To fit properly, crown molding must be compound-mitered with extreme accuracy. The two surfaces on a piece of crown molding that fit flat against the ceiling and wall are at angles that, when added together equal exactly 90°.

Most crown molding has a top rear angle (the section that fits flat against the ceiling) of 52° and a bottom rear angle (the section that fits flat against the wall) of 38°.

In order to accurately cut crown molding for a 90° inside or outside corner, lay the molding with its broad back surface flat on the saw table.

When setting the bevel and miter angles for compound miters, remember that the settings are interdependent; changing one changes the other, as well. Also keep in mind that the angles from crown molding are very easy for these angles to shift slightly, all settings should be tested on scrap molding.

Use crown molding hold-down clamp, whenever possible, and place tape on the area being clamped to avoid marks.

Fig.AA

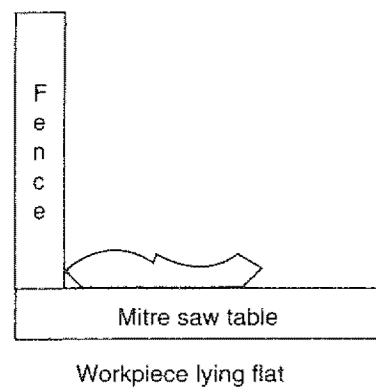

Fig.BB

Settings for standard crown molding lying flat on compound miter saw table

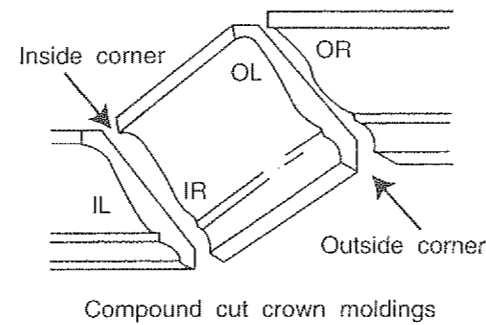
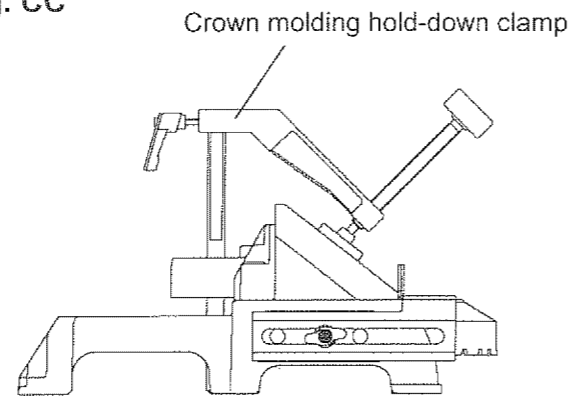

Fig. CC



Bevel/Miter Settings

KEY	BEVEL SETTING	MITER SETTING	TYPE OF CUT
Inside corner-Left side			
IL	33.9°	31.6° Right	1. Position top of molding against fence. 2. Miter table see at RIGHT 31.6°. 3. LEFT side is finished piece.
Inside corner-Right side			
IR	33.9°	31.6° Left	1. Position bottom of molding against fence. 2. Miter table see at LEFT 31.6°. 3. LEFT side is finished piece.
Outside corner-Left side			
OL	33.9°	31.6° Left	1. Position bottom of molding against fence. 2. Miter table see at LEFT 31.6°. 3. RIGHT side is finished piece.
Outside corner-Right side			
OR	33.9°	31.6° Right	1. Position top of molding against fence. 2. Miter table see at RIGHT 31.6°. 3. RIGHT side is finished piece.

MAINTENANCE

MAINTENANCE

DANGER

Never put lubricants on the blade while it is spinning.

▲ WARNING

To avoid fire or toxic reaction, never use gasoline, naphtha acetone, lacquer thinner or similar highly volatile solvents to clean the miter saw.

▲ WARNING

To avoid injury from unexpected starting or electrical shock, unplug the power cord before working on the saw.

▲ WARNING

For your safety, this saw is double-insulated. To avoid electrical shock, fire or injury, use only parts identical to those identified in the parts list. Reassemble exactly as the original assembly to avoid electrical shock.

REPLACING CARBON BRUSHES (FIG. DD)

The carbon brushes furnished will last approximately 50 hours of running time, or 10,000 ON/OFF cycles. Replace both carbon brushes when either has less than 1/4" length of carbon remaining, or if the spring or wire is damaged or burned. To inspect or replace brushes, first unplug the saw. Then remove the black plastic cap (1) on the side of the motor (2). Remove the cap cautiously, because it is springloaded. Then pull out the brush and replace. Replace for the other side. To reassemble reverse the procedure. The ears on the metal end of the assembly go in the same slot the carbon part fits into. Tighten the cap snugly, but do not overtighten.

NOTE: To reinstall the same brushes, first make sure the brushes go back in the way they came out. This will avoid a break-in period that reduces motor performance and increase wear.

Fig.DD

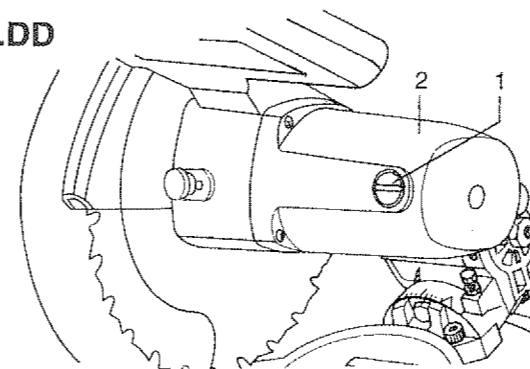

LOWER BLADE GUARD

Do not use the saw without the lower blade guard. The lower blade guard is attached to the saw for your protection. Should the lower guard become damaged, do not use the saw until the damaged guard has been replaced. Develop a regular check to make sure the lower guard is working properly. Clean the lower guard of any dust or buildup with a damp cloth.

CAUTION: Do not use solvents on the guard. They could make the plastic "cloudy" and brittle.

▲ WARNING

When cleaning the lower guard, unplug the saw from the power source receptacle to avoid unexpected startup.

SAWDUST

Periodically, sawdust will accumulate under the work table and base. This could cause difficulty in the movement of the worktable when setting up a miter cut. Frequently blow out or vacuum up the sawdust.

▲ WARNING

If blowing sawdust, wear proper eye protection to keep debris from blowing into eyes.

LUBRICATION

All the motor bearings in this tool are lubricated with a sufficient amount of high grade lubricant for the life of the unit under normal operating conditions; therefore, no further lubrication is required.

Lubricate the Following as Required:

Chop pivot: light machine oil or aerosol will penetrate from the ends of the junction points. A qualified service technician can remove the pivot bumper to relieve tension, and the 2 metric set screws holding the shaft, in order to drive the shaft about 3/4" right. Exposed surfaces should be lubricated with automotive type oil.

Central pivot of plastic guard: Use light household oil (sewing machine oil) on metal-to-metal or metal-to-plastic guard contact areas as required for smooth, quiet operation. Avoid excessive oil, to which sawdust will cling.

Link: (which actuates the lower guard movement) may be oiled at the rear pivot, greased at ball bearing contact, and oiled where the link actuates the roller of the lower guard, if the down chop motion is hard to start.

TROUBLESHOOTING GUIDE

▲ WARNING

To avoid injury from accidental starting, always turn switch OFF and unplug the tool before moving, replacing the blade or making adjustments.

Consult your Sears Service Center if for any reason the motor will not run.

TROUBLESHOOTING GUIDE - MOTOR

PROBLEM	PROBLEM CAUSE	SUGGESTED CORRECTIVE ACTION
Brake does not stop blade within 6 seconds.	<ol style="list-style-type: none"> 1. Motor brushes not sealed or lightly sticking. 2. Motor brake overheated from use of defective or wrong size blade or rapid ON/OFF cycling. 3. Arbor screw loose. 4. Other. 	<ol style="list-style-type: none"> 1. Inspect / clean / replace brushes. See MAINTENANCE section. 2. Use a recommended blade. Let cool down. 3. Retighten. 4. Sears Service Center.
Motor does not start	<ol style="list-style-type: none"> 1. Fuse 2. Brush worn. 3. Other. 	<ol style="list-style-type: none"> 1. 15-Amp time delay fuse, or circuit breaker. 2. See MAINTENANCE section. 3. Sears Service Center.
Brush spark when switch released.	<ol style="list-style-type: none"> 1. Fuse 2. Brush worn. 3. Other. 	<ol style="list-style-type: none"> 1. None.

TROUBLESHOOTING GUIDE – SAW OPERATION

PROBLEM	PROBLEM CAUSE	SUGGESTED CORRECTIVE ACTION
Blade hits table.	<ol style="list-style-type: none"> 1. Misalignment. 	<ol style="list-style-type: none"> 1. Sears Service Center. See ADJUSTMENT section.
Angle of cut not accurate. Can't adjust miter.	<ol style="list-style-type: none"> 1. Miter table locked. 2. Sawdust under table. 	<ol style="list-style-type: none"> 1. Squeeze miter spring lock up. See OPERATION Section. 2. Vacuum or blow out dust, WEAR EYE PROTECTION.
Cutting arm wobble.	<ol style="list-style-type: none"> 1. Loose pivot points. 	<ol style="list-style-type: none"> 1. See ADJUSTMENT Section.
Cutting arm won't fully raise, or blade guard won't fully close.	<ol style="list-style-type: none"> 1. Part failure. 2. Pivot spring not replaced properly after service. 3. Sawdust build-up. 	<ol style="list-style-type: none"> 1. Sears Service Center. 2. Sears Service Center. 3. Clean and lubricate moving parts.
Blade binds, jams, and burns wood.	<ol style="list-style-type: none"> 1. Improper operation. 2. Dull blade. 3. Improper blade size. 4. Warped blade. 	<ol style="list-style-type: none"> 1. See BASIC SAW OPERATION section. 2. Replace or sharpen blade. 3. Replace with 10" diameter blade. 4. Replace blade.
Saw vibrates or shakes.	<ol style="list-style-type: none"> 1. Saw blade not round. 2. Saw blade damaged. 3. Saw blade loose. 4. Other. 	<ol style="list-style-type: none"> 1. Replace blade. 2. Replace blade. 3. Tighten arbor screw. 4. Sears Service Center.

NOTE

PARTS

CRAFTSMAN COMPOUND MITRE SAW

MODEL NO. 137.242750

▲ WARNING

When servicing use only CRAFTSMAN replacement parts. Use of any other parts may create a HAZARD or cause product damage. Any attempt to repair or replace electrical parts on this Miter Saw may create a HAZARD unless repair is done by a qualified service technician. Repair service is available at your nearest Sears Service Center.

Order by PART NUMBER, not by key number

PARTS LIST FOR SCHEMATIC A

Key	Part No.	Description	Size	Qty
1	2615BDBC20	HEX. HD. SCREW & WASHER	M6X1.0-25	2
2	12700203	ARM-MITER		1
3	12700302	COIL SPRING		1
4	2663MHCK16	CR. RE. PAN HD. SCREW	M5X0.8-10	4
5	2501MBDN85	FLAT WASHER	5X16-2	4
6	12700604	TABLE		1
7	12700702A1	LOCKING HANDLE ASS'Y		1
8	12700802	PLASTIC SLEEVE		1
9	2668BBDA32	CR. RE. PAN HD. SCREW	M5X0.8-10	1
10	12701002	NEEDLE POINTER		1
11	2652MHCK16	CR. RE. PAN HD. SCREW	M5X0.8-8	3
12	12701201	FOLLOWER PLATE		3
13	12701302	TABLE INSERT		1
14	2660PBCK12	CR. RE. PAN HD. TAPPING SCREW	M4X18-10	4
15	12701505	TILTING SCALE		1
16	12701602	BASE		1
17	16503601	SHAFT		1
18	2617BBLB58	HEX. SOC. HD. CAP SCREW	M8X1.25-35	2
19	12702203	SUPPORT		1
20	2501NBDN40	FLAT WASHER	1/2X1-3/64	1
21	2705FBD112	NUT CHUCK	M12X1.75 T=12	1
22	16505002	KNOB-HANDLE		1
23	2701FBD106	HEX. NUT	M6X1.0 T=5	1
24	2801BBDA41	HEX. HD. BOLT	M6X1.0-20	1
25	2574B55R02	O-RING ROD		1
26	16503401	BRACKET STOP		1
27	12703004	FENCE		1
28	2617BBLD60	HEX. SOC. HD. CAP SCREW	M8X1.25-45	2
29	2601BDLA43	HEX. SOC. HD. CAP SCREW	M6X1.0-30	2
30	2601BZDAD4	HEX. SOC. SET SCREW	M10X1.5-75	1
31	2606BDLA32	HEX. HD. BOLT	M5X0.8-10	1
32	12703503	BRACKET-TILT		1
33	2658MBDU36	DRIVE SCREW	2.3-5	2
34	12703701	SHAFT-PIVOT		1
35	2668BBDA32	CR. RE. PAN HD. SCREW	M5X0.8-10	2
36	12703902	NEEDLE POINTER		2
37	12704001	FLAT WASHER	6X13-1	1
38	12704101	ANGLE PEGULATOR		1
39	2501MBDN11	FLAT WASHER	10X20-2	1
40	2705FBD110	NUT CHUCK	M10X1.5 T=10	1
41	2501MBDN26	FLAT WASHER	10X20-3	1
42	16304201A1	LOCKING HANDLE ASS'Y		1
43	2617BBLD28	HEX. SOCKET HD. CAP SCREWS	M8X1.25-25	1
44	2705FZD106	NUT CHUCK	M6X1.0 T=6	1
45	12704901	ASSIST-FENCE		1
46	12705001	BLADE HOLDER		1
47	12705101	CUSHION		1
48	12705201A1	LOCKING HANDLE ASS'Y		1
49	2617BDLC15	HEX. SOC. HD. CAP BOLT	M5X0.8-16	2
50	12705701	BRACKET		1
51	12705802	SCREW STOP		1
52	12705901	LOCK NUT		1
53	17803601	COMPRESSION SPRING		1
54	2570BBN206	E-RING	E-6	1
55A	12706501A1	LOCKING HANDLE ASS'Y		1
56	12706601	PIN		1
57	12706701	CAUTION LABEL		1
58	2501NZDN06	FLAT WASHER	6X13-1	1
138	2504MBC006	TOOTH WASHER		1

CRAFTSMAN COMPOUND MITRE SAW

MODEL: 137.242750

schematic A

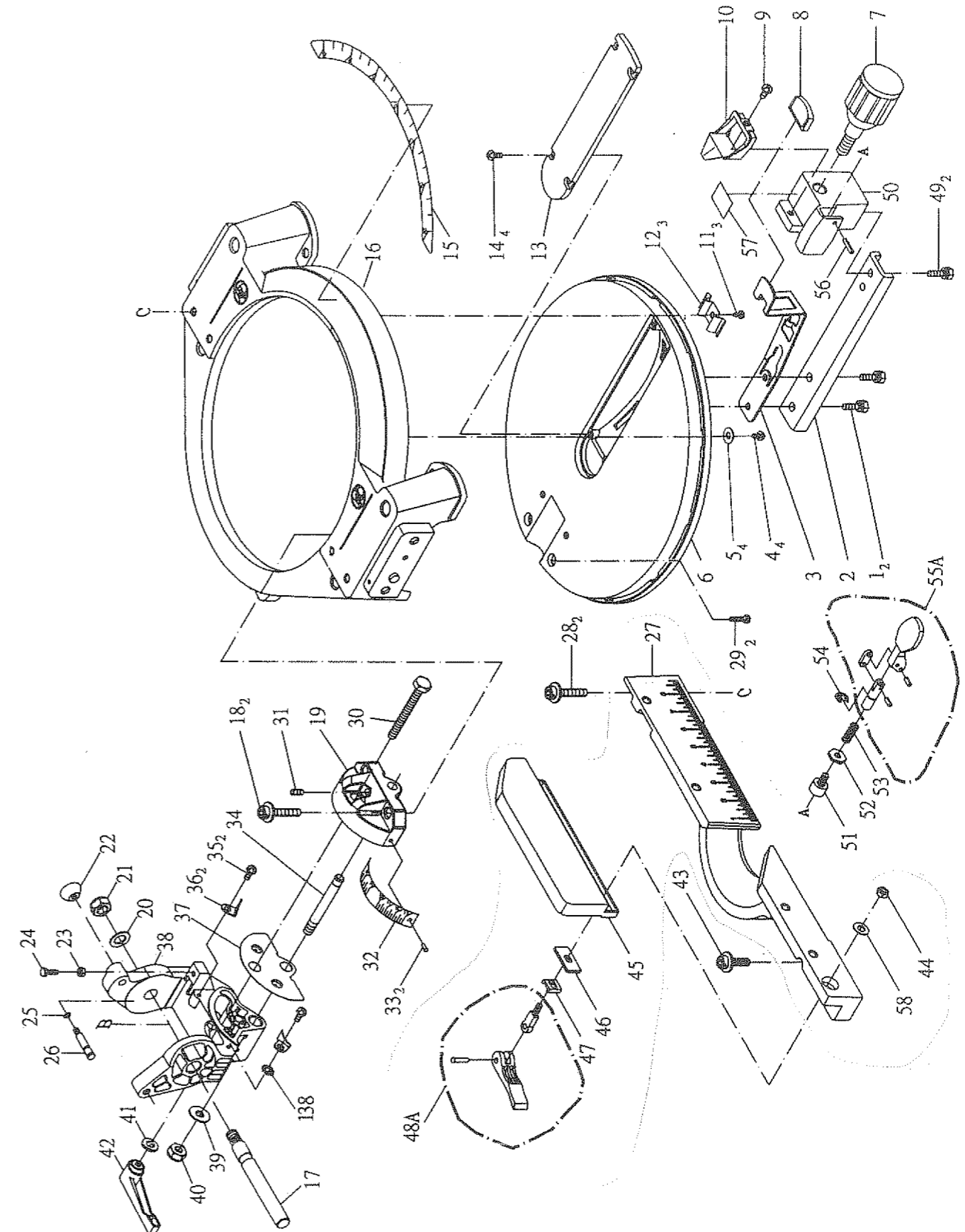

PARTS

CRAFTSMAN COMPOUND MITRE SAW

MODEL:137.242750

Parts list for schematic B

Key	Part No.	Description	Size	Qty	Key	Part No.	Description	Size	Qty
59	16933401	WRENCH HEX.		1	99	2660PBCK23	CR. RE. PAN HD. SCREW	M4X18-25	2
60	2607BBLW55	HEX. WASHER HD. BOLT	M8X1.25-20	1	100	2805U5HN16	TERMINAL		1
61	16930402	ARBOR COLLAR		2	101	2807BS08Z3	POWER CABLE		1
62	14930201	BLADE		1	102	2668BBDA42	CR. RE. PAN HD. SCREW	M6X1.0-25	3
63	12710401	SHAFT SLEEVE		1	103	2660PBCK20	CR. RE. PAN HD. TAPPING SCREW	M5X16-25	4
64	16510501	TORSION SPRING		1	104	16221901	SPRING WIRE		1
65	8596829149	MOTOR		1	105	12715207	HANDLE		1
66	2642BZDA69	CR. RE. TRUSS HD. ROUND NECK SCREW	M6X1.0-14	1	106	12717901	HANDLE SEAT		1
67	16510801	LEVER		1	107	12718001	HANDLE SEAT		1
68	2501MBDN06	FLAT WASHER	6X13-1	1	108	12718102	CLAMP HANDLE		1
69	2636BBDA40	CR. RE. COUNT HD. SCREW	M6X1.0-16	1	109	2535MNCB19	PIN		1
70	16511101	COLLAR		1	110	12718301	BOLT		1
71	16511204A2	PC-GUARD ASS'Y		1	111	12718401	CUSHION		1
72	16513001	CAUTION LABEL		1	112	2501MZDN81	FLAT WASHER	φ 8X25-3.0	2
73	2701FBD106	HEX. NUT	M6X1.0 T=5	1	113	2506MBN614	WAVE WASHER	φ 8.2X18-2.0	1
74	16821601	SPRING GUARD		1	114	12718701	SET PLATE		1
75	2636BBDA24	CR. RE. COUNT HD. SCREW		1	115	2705FBD108	NUT CHUCK		1
76	16510601A2	HOUSING ASS'Y		1	116	12719002	SPRING PLATE		1
77	2660PBCK14	CR. RE. PAN HD. TAPPING SCREW	M4X18-16	3	117	2660MBCE16	CR. RE. TRUSS HD. TAPPING SCREW	M5X12-10	1
78	2668BBDA07	CR. RE. PAN HD. SCREW	M4X0.7-8	2	118	280255H506	CABLE CLAMP		1
79	16513201	CHIP PLATE		1	119	12719401	LOCK HANDLE		1
80	16513301	RUBBER PAD		1	120	2536MBE669	SPRING PIN		1
81	2642BZDA69	CR. RE. TRUSS HD. ROUND NECK SCREW	M6X1.0-14	1	121	12719602	COMPRESSION SPRING		1
82	12713240	TRADE-MARK LABEL		1	122	2570BBN204	C-RING		1
83	2705FBBD106	NUT CHUCK	M6X1.0 T=6	1	123	12719801	BRACKET STOP		1
84	2606BDLA38	HEX. SOC. SET SCREW	M6X1.0-10	2	124	12719901	TILTING SCALE		1
85	16323204A1	BAG-DUST ASS'Y		1	125	280655545Y	LEAD WIRE ASS'Y		1
86	16512201	SHIM		1	126	16211001	BUMPER		1
87	16512301	ANCHOR BLOCK		1	127	12720701	TRADE-MARK LABEL		1
88	2602BBLA40	HEX. SOC. HD. CAP BOLT	M6X1.0-16	1	128	2501MBDN50	FLAT WASHER	φ 8.2X18-2.0	1
89	12713216	LABEL		1	129	12720901	ELBOW		1
90	12713306	TRIGGER		1	130	16961501	EXTENSION WING		2
91	16203001	SPRING		1	131	2668BBDA26	CR. RE. PAN HD. SCREW	M5X0.8-18	2
92	2856D55309	LIMITS SWITCH		1	132	16961202A1	STOP BLOCK		1
93	2660PBCK57	CR. RE. PAN HD. TAPPING SCREW	M4X18-28	5	133	2671QZDK36	WING BOLT		1
94	12713707	HANDLE		1	134	12740301A1	WISE ASS'Y		1
95	12713807	BUTTON SWITCH		1	135	12732001	PLATE		1
96	12713901	SPRING		1	136	12732101	PLATE		1
97	12714101	CLAMP-CORD		1	137	19500203	LOCK HANDLE		2
98	83990141	GUARD-CORD		1					

CRAFTSMAN COMPOUND MITRE SAW

MODEL: 137.242750

Schematic B

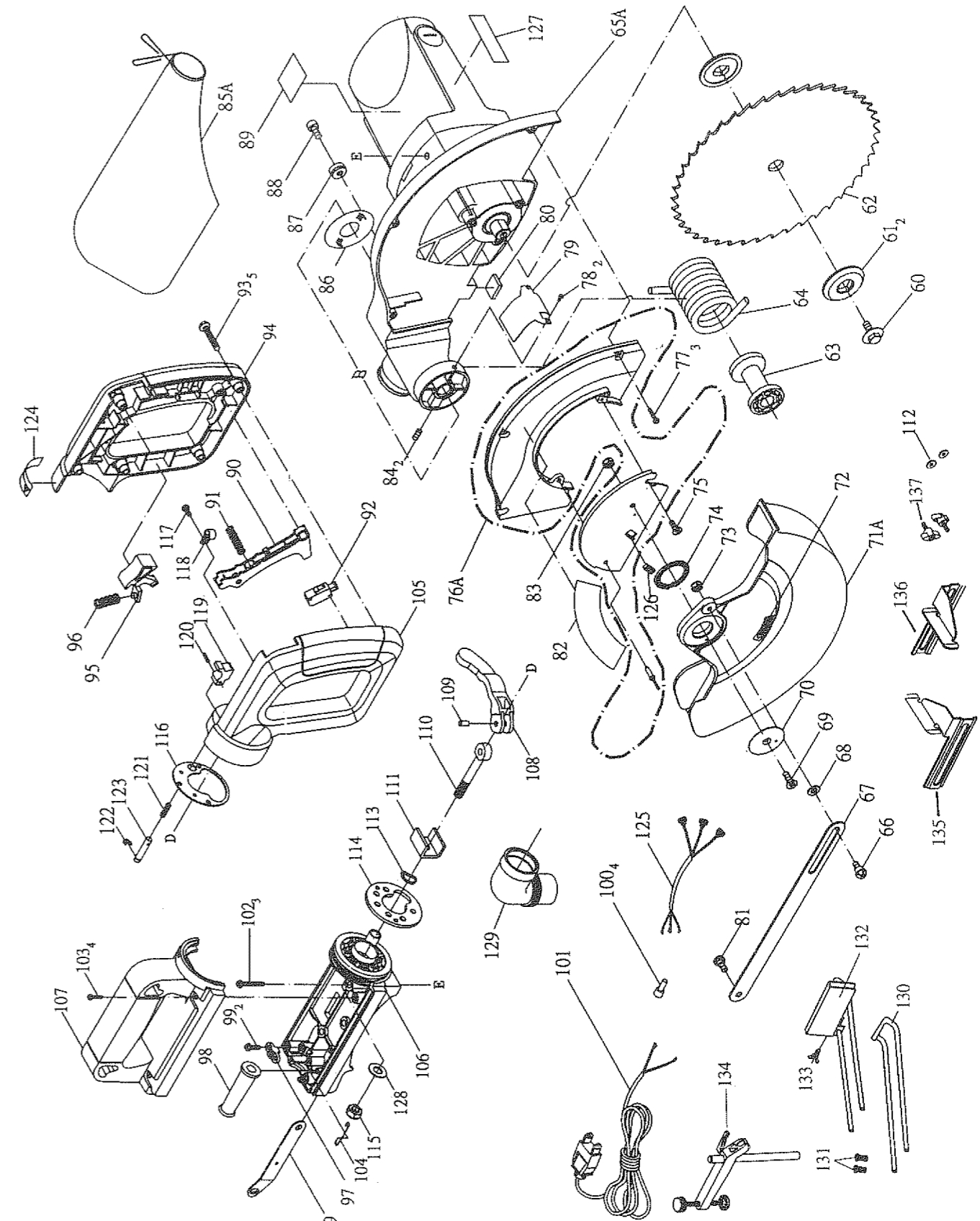

PARTS

CRAFTSMAN COMPOUND MITRE SAW

MODEL:137.242750

Parts list for schematic C

MOTOR

Key	Part No.	Description	Size	Qty
01	83965011	ARBOR SHAFT		1
02	2571MNC311	PARALLEL KEY		1
03	2641BBDA24	CR.-RE. ROUND HD. WASHER SCREW	M5×0.8-10	3
04	83965041	BEARING COVER	5	1
05	2001ZZ6204	BALL BEARING	6204ZZ	1
06	2570BBN120	C-RING	A-20	1
07	83965071	HELIX GEAR		1
08	2570BBN114	C-RING	A-14	1
09	2004AH1010	NEEDLE BEARING	HK-1010	1
10	83920172	COMPRESSION SPRING		1
11	8396511C	ARM UPPER		1
12	2536MBE607	SPRING PIN		1
13	83965131	BRACKET STOP		1
14A	83966141A1	ARMATURE		1
15	280655563Y	LEAD WIRE ASS'Y		1
16	83990331	BEARING BUSHING		1
17	83750081	FLOW GUIDE		1
18A	85968181A2	FIELD ASS'Y		1
19	2662MZDE61	CR.-RE.PAN HD.TAPPING	M5×12-55	2
20	83968201	PROTECTOR WIRE		1
21	83965261	PLASTIC CAP		1
22	83968223	MOTOR HOUSING		1
23	2620BBDB26	CR.-RE.PAN HD.TAPPING SCREW & WASHER	M5×16-30	4
24	2603BBLA20	HEX.-SOC SET SCREW	M5×0.8-6	2
25	2686BBHA22	PLASTIC SCREW	M5×0.8-6	2
26A	83990282A1	BRUSH HOLDER ASS'Y		2
27A	83990291A1	RUBBER BUSHING		2
28	83990301	BRUSH COVER		2

CRAFTSMAN COMPOUND MITRE SAW

MODEL: 137.242750

Schematic C

